

DUCATI SCRAMBLER 800 Workshop Manual 2015

- S.01 - General
 - Symbols - Abbreviations - References
 - [Product specifications](#)
 - Dangerous products - warnings
 - [General maintenance instructions](#)
 - [General safety rules](#)
- S.02 - Model-specific information
 - Model identification
 - [Identification data](#)
- S.03 - Technical data
 - Technical specifications
 - [Lights/instrument panel](#)
 - [Injection system](#)
 - [Fuel system](#)
 - [Injection-ignition system](#)
 - [Charging system/generator](#)
 - [Hydraulic brakes](#)
 - [Rear suspension](#)
 - [Rear wheel](#)
 - [Front suspension](#)
 - [Front wheel](#)
 - [Cooling system](#)
 - [Gearbox](#)
 - [Cylinder/piston](#)
 - [Crankshaft](#)
 - [Timing system/valves](#)
 - [Transmission](#)
 - [Colours](#)
 - [General](#)
 - Overall dimensions
 - [Overall dimensions](#)
 - Fuel, lubricants and other fluids
 - [Fuel, lubricants and other fluids](#)
 - Tightening torque settings
 - [Engine tightening torque values](#)
 - [Frame tightening torque values](#)
 - Service tools
 - [Diagnosis special tools](#)
 - [Frame special tools](#)
 - [Engine special tools](#)
- S.04 - Maintenance operations
 - Vehicle pre-delivery
 - [Vehicle pre-delivery](#)
 - Scheduled maintenance chart
 - [Operations to be carried out by the customer](#)
 - [Operations to be carried out by the dealer](#)
 - Maintenance operations
 - [Adjusting the rear shock absorber](#)
 - [Adjusting the position of the gearchange pedal and rear brake pedal](#)
 - [Adjusting the front brake control lever](#)
 - [Adjusting the throttle cable](#)
 - [Checking rear brake pad wear and replacing brake pads](#)
 - [Checking front brake pad wear and replacing brake pads](#)
 - [Adjusting the chain tension](#)
 - [Adjusting the steering head bearing play](#)

- Clutch control cable adjustment
- Changing the fluid in the rear brake system
- Changing the fluid in the front brake system
- Changing and cleaning the air filters
- Replacing the spark plugs
- Changing the timing belts
- Checking valve clearance
- Changing the engine oil and filter cartridge
- Check engine oil level
- S.05 - Fairings
- Rear-view mirrors
 - Refitting the rear-view mirrors
 - Removing the rear-view mirrors
- Seat - tail guard - side body panels
 - Refitting the tail guard (CLASSIC)
 - Removing the tail guard (CLASSIC)
 - Refitting the seat release mechanism
 - Removing the seat release mechanism
 - Refitting the tail guard
 - Removing the tail guard
 - Refitting the rear side body panels
 - Removing the rear side body panels
 - Refitting the seat
 - Removing the seat
- Mudguard
 - Refitting the front mudguard (URBAN ENDURO)
 - Removing the front mudguard (URBAN ENDURO)
 - Refitting the front mudguard
 - Removing the front mudguard
- Belly pan
 - Refitting the belly pan (URBAN ENDURO)
 - Removing the belly pan (URBAN ENDURO)
- S.06 - Electric system and engine management
- Wiring diagram
 - Table Z
 - Table Y
 - Table X
 - Table W
 - Table V
 - Table U
 - Table T
 - Table S
 - Table R
 - Table Q
 - Table P
 - Table O
 - Table N
 - Table M
 - Table L
 - Table K
 - Table J
 - Table H
 - Table G
 - Table F
 - Table E
 - Table D
 - Table C
 - Table B
 - Table A
 - Routing of wiring on frame
 - Fuse box key
 - Wiring diagram cable colour codes
 - Key to wiring diagram

- Charge system - Battery
 - Rectifier-regulator
 - Alternator
 - Battery
 - Topping up the electrolyte
 - Recharging the battery
 - Checking the battery charging system
- Electric starter
 - Solenoid starter
 - Starter motor
 - Electric starting system
- Lighting
 - Aligning the headlight
 - Changing bulbs
- Instrument panel
 - Entering PIN CODE function for overriding purposes
 - Key duplication
 - Operation
 - Keys
 - Immobilizer system
 - Light control
 - Setting the units of measurement
 - Changing the PIN CODE
 - Pin Code
 - Clock setting function (CLOCK)
 - Instrument panel back-lighting setting (B.LIGHT)
 - Battery voltage
 - ABS control unit enabling/disabling
 - Setting menu
 - DESMO SERVICE indication
 - DESMO SERVICE countdown indication
 - OIL SERVICE zero warning
 - Service indication (SERVICE)
 - High engine temperature
 - Clock
 - Displayed errors description
 - Error warnings
 - Errors
 - Ambient air temperature (AIR)
 - Partial fuel reserve counter (TRIP FUEL)
 - Trip meter 2 (TRIP 2)
 - Trip meter 1 (TRIP 1)
 - Odometer (TOT)
 - Menu 1 functions
 - Engine rpm indication (RPM)
 - Motorcycle speed
 - Main functions
 - Parameter setting/displaying
 - Function buttons
 - Technological Dictionary
 - Acronyms and abbreviations used in the Manual
 - Instrument panel
- System components
 - Diagnostic socket
 - Main relay and injection
 - Timing/rpm sensor
 - Throttle position potentiometer
 - Coil
 - Ignition spark plug
 - Temperature sensor
 - Air pressure sensor
 - Lambda sensor
 - Stepper motor
 - Electric injector
 - Electronic control unit

- S.07 - Chassis
- Front wheel
 - Overhauling the front wheel (URBAN ENDURO)
 - Overhauling the front wheel (CLASSIC)
 - Refitting the front wheel
 - Overhauling the front wheel
 - Removing the front wheel
- Rear wheel
 - Overhauling the rear wheel (URBAN ENDURO)
 - Overhauling the rear wheel (CLASSIC)
 - Refitting the rear wheel
 - Overhauling the rear wheel
 - Removing the rear wheel
- Front brake control
 - Refitting the front brake system
 - Refitting the brake disc
 - Overhauling the front brake components
 - Removing the brake disc
 - Removing the front brake system
 - Maintenance operations
 - Refitting the front brake master cylinder
 - Removing the front brake master cylinder
- Rear brake
 - Refitting the rear brake disc
 - Removing the rear brake disc
 - Refitting the rear brake calliper
 - Removing the rear brake calliper
 - Refitting the rear brake control
 - Disassembling the rear brake control
 - Removing the rear brake control
- ABS system information
 - ABS system deactivation
 - ABS system operation information
 - Operating principle
- ABS system components
 - Routing wiring harnesses/hoses
 - Refitting the ABS control unit
 - Removing the ABS control unit
 - Changing the rear phonic wheel sensor
 - Changing the front phonic wheel sensor
- ABS component maintenance
 - Bleeding of the ABS hydraulic system
 - Adjusting the AIR-GAP of phonic wheel sensor
- Handlebar assembly: throttle control
 - Refitting the throttle control
 - Removing the throttle control
 - Adjusting the throttle cable
 - Refitting the handlebar
 - Removing the handlebar
- Handlebar assembly: clutch control
 - Refitting the clutch assembly
 - Removing the clutch assembly
- Handlebar assembly: ignition switch
 - Refitting the ignition switch
 - Removing the ignition switch
- Gear selector control
 - Refitting the gear change control
 - Disassembling the gear change control
 - Removing the gear change control
- Fork - steering head: front fork
 - Refitting the front fork
 - Overhauling the front fork
 - Removing the front fork
- Fork - steering head: steering assembly

- Refitting the steering tube components
 - Removing the steering tube components
 - Steering angle adjustment
 - Adjusting the steering head bearing clearance
- Rear shock absorber assembly
 - Refitting the rear suspension
 - Overhauling the rear shock absorber
 - Removing the rear shock absorber
 - Rear suspension system
- Swinging arm
 - Refitting the rear swinging arm
 - Overhauling the rear swinging arm
 - Inspecting the swinging arm shaft
 - Removing the swinging arm
- Final drive
 - Lubricating the chain
 - Washing the chain
 - Refitting the rear sprocket
 - Removing the rear sprocket
 - Refitting the front sprocket
 - Removing the front sprocket
 - Inspection of the final drive
- Footrest support
 - Refitting the rear footpegs
 - Removing the rear footpegs
 - Refitting the front footpeg support
 - Removing the front footpeg support
 - Refitting the front footpegs
 - Removing the front footpegs
- Stands
 - Refitting the side stand
 - Removing the side stand
- Inspecting the frame
 - Checking the frame
 - Refitting the structural parts and frame
 - Removing structural components and frame
- Tail light - number plate holder
 - Rimontaggio fanale posteriore
 - Smontaggio fanale posteriore
 - Refitting the number plate holder
 - Removing the number plate holder
- Electrical components compartment
 - Refitting the electric components compartment
 - Removing the electric components compartment
- S.08 - Fuel/Exhaust system
- Fuel tank
 - Refitting the fuel tank
 - Refitting the fuel tank flange
 - Removing the fuel tank flange
 - Refitting the tank filler plug
 - Removing the tank filler plug
 - Removing the fuel tank
- Airbox – throttle body
 - Refitting the throttle body
 - Removing the throttle body
 - Refitting the airbox
 - Removing the airbox
- Air intake
 - Refitting the secondary air system
 - Removing the secondary air system
 - Refitting the air filters
 - Removing the air filters
- Exhaust system
 - Refitting the silencer (FULL THROTTLE)

- Removing the silencer (FULL THROTTLE)
 - Refitting the exhaust system
 - Removing the exhaust system
 - Refitting the silencer
 - Removing the silencer
- Canister filter
 - Refitting the Canister filter
 - Removing the canister filter
 - Canister filter system
- S.09 - Engine
- Removing - refitting the complete engine
 - Refitting the engine
 - Removing the engine
- Lubrication system: oil pump
 - Refitting the oil pump
 - Reassembling the oil pump
 - Disassembling the oil pump gear
 - Removing the oil pump
- Lubrication system: oil cooler
 - Refitting the lubrication system
 - Inspecting the oil cooler
 - Removing the lubrication system
- Cylinder head assembly: checks and adjustments
 - Checking the engine timing
 - Checking valve lift
 - Checking and adjusting the valve clearance
- Cylinder head assembly: timing system
 - Refitting the timing outer covers
 - Refitting the timing belts
 - Refitting the cylinder heads pulleys/idler pulleys
 - Reassembling the timing pulleys
 - Refitting the timing layshaft pulley
 - Removing the timing layshaft pulleys
 - Disassembling the camshaft pulleys
 - Removing the cylinder head pulley/fixed tensioner
 - Removing the mobile tensioner/timing belt
 - Removing the timing belt covers
- Cylinder head assembly: camshafts
 - Refitting the intake manifold
 - Removing the intake manifold
 - Refitting the camshafts
 - Check of the camshafts and supports
 - Removing the camshafts
- Cylinder head assembly: valves - rocker arms
 - Refitting the cylinder heads
 - Refitting the valves and rocker arms
 - Overhauling the cylinder head components
 - Removing the valves and rocker arms
 - Removing the cylinder heads
- Cylinder/piston assembly
 - Refitting the cylinder/piston assembly
 - Overhauling the cylinder/piston components
 - Removing the cylinder/piston assembly
- Clutch assembly: clutch
 - Refitting the clutch
 - Checking and overhauling the components
 - Removing the clutch
 - Description of the clutch assembly
- Clutch assembly: clutch cover
 - Refitting the clutch cover
 - Reassembling the clutch cover
 - Disassembling the clutch cover
 - Removing the clutch cover
- Clutch assembly: primary drive gears

- Refitting the primary drive gears and checking backlash
 - Removing the primary drive gears
- Gearbox assembly: linkages
 - Refitting the gearchange mechanism
 - Refitting the gear interlock plunger and ratchet
 - Disassembling gear interlock plunger and ratchet
 - Removing the gearchange mechanism
- Gearbox assembly: gearbox shafts
 - Reassembling the gearbox assembly
 - Reassembling the gearbox shafts
 - Inspecting the fork selector drum
 - Inspecting the gear selector forks
 - Overhauling the gearbox
 - Disassembling the gearbox shafts
 - Removing the gearbox assembly
- Flywheel - generator
 - Refitting the flywheel/generator assembly
 - Overhauling the flywheel/generator assembly
 - Removing the flywheel/generator assembly
 - Refitting the generator cover
 - Reassembling the generator cover
 - Disassembling the generator cover
 - Removing the generator cover
- Crankcase: external components
 - Refitting the starter motor
 - Removing the starter motor
 - Refitting the starter motor idler gear
 - Removing the starter motor idler gear
 - Refitting the timing gears
 - Removing the timing gears
 - Refitting the external components
 - Removing outer components
- Crankcase: casings
 - Closing the crankcase
 - Shimming the shafts
 - Reassembling the crankcase halves
 - Main bearings
 - Overhauling the crankcase halves
 - Separating the crankcase halves
- Crankcase: connecting rod assembly
 - Reassembling the connecting rod assembly
 - Overhauling the connecting rod assembly
 - Disassembling the connecting rod assembly
 - Removing the connecting rod assembly

Symbols - Abbreviations - References

To allow quick and easy consultation, this manual uses graphic symbols to highlight situations in which maximum care is required, as well as practical advice or information. Pay attention to the meaning of the symbols since they serve to avoid repeating technical concepts or safety warnings throughout the text. The symbols should therefore be seen as real "reminders". Please refer to this page whenever in doubt as to their meaning.

The terms right-hand and left-hand refer to the motorcycle viewed from the riding position.

Warning

Failure to comply with these instructions may put you at risk, and could lead to severe injury or even death.

Important







Failure to follow the instructions in text marked with this symbol can lead to serious damage to the motorcycle and its components.















Note













This symbol indicates additional useful information for the current operation.

Product specifications

Symbols in the diagram show the type of threadlocker, sealant or lubricant to be used at the points indicated. The table below shows the symbols used and the specifications of the various products.

Symbol	Specifications	Recommended product
	Engine oil (for characteristics see Fuel, lubricants and other fluids).	SHELL Advance 4T Ultra
	DOT 4 special hydraulic brake fluid.	SHELL Advance Brake DOT 4
	SAE 80-90 gear oil or special products for chains with O rings.	SHELL Advance Chain or Advance Teflon Chain
	Anti-freeze (nitride, amine and phosphate free) 30 to 40% + water.	SHELL Advance coolant or Glycoshell
	GREASE A Multipurpose, medium fibre, lithium grease.	SHELL Alvania R3
	GREASE B Molybdenum disulphide grease, high mechanical stress and high temperature resistant.	SHELL Retinax HDX2 or SHELL Gadius S2 V220 AD 2
	GREASE C Bearing/joint grease for parts subject to prolonged mechanical stress. Temperature range: -10 to 110 °C.	SHELL Retinax LX2

	GREASE D	Protective grease, with anti-corrosive and waterproofing properties.	SHELL Retinax HD2
	GREASE E	Grease	PANKL - PLB 05
	GREASE F	Grease	OPTIMOL - PASTE WHITE T
	GREASE G	Grease	PANKL - PLB07
	GREASE H	Grease	KLÜBER STABURAGS NBU 30 PTM
	GREASE I	Copper grease	CUPRUM 320
	LOCK 1	Low-strength threadlocker.	Loctite 222
	LOCK 2	Medium-strength threadlocker, compatible with oil.	Loctite 243 (or THREE BOND TB1324)
	LOCK 3	High-strength threadlocker for threaded parts.	Loctite 270
	LOCK 4	Surface sealant resistant to high mechanical stress and solvents. Resists high temperatures (up to 200 °C) and pressures up to 350 bar; fills gaps up to 0.4 mm.	Loctite 510
	LOCK 5	Permanent adhesive for freely sliding cylindrical couplings or threaded couplings on mechanical parts. High resistance to mechanical stress and solvents. Temperature range: 55 to 175 °C.	Loctite 128455 (former 648 BV)
	LOCK 6	Pipe sealant for pipes and medium to large fittings. For water and gases (except oxygen). Maximum filling capacity: 0.40 mm (diameter clearance).	Loctite 577
	LOCK 7	Instant adhesive for rubber and plastics with elastomer charged ethylic base.	Loctite 480
	LOCK 8	High-strength retaining compound for threaded parts, bearings, bushes, splines and keys. Operating temperature range: 55 to 150 °C.	Loctite 601 (As an alternative THREE BOND TB1378B)

	LOCK 9	Medium-strength threadlocker.	Loctite 406
	LOCK 10	Product for metal parts to seal and lock freely sliding cylindrical couplings or threaded couplings. Resistant to high mechanical stress and high temperature, excellent resistance to solvents and chemical attack.	Loctite 128443 (former 648 AV)
	LOCK 11	Medium-strength threadlocker.	Loctite 401
	LOCK 12	Instant adhesive gel offering tensile/shear strength.	Loctite 454 gel
		DUCATI sealing compound.	THREE BOND 1215
		Sealing compound	THREE BOND 1207B
		Exhaust pipe sealing compound. Self-sealing paste hardens when heated and resists temperatures exceeding 1000 °C.	Holts Firegum
		Spray used to protect electric systems. Eliminates moisture and condensation and provides excellent corrosion resistance. Water repellent.	SHELL Advance Contact Cleaner
		Dry lubricant, polymerising on contact with air.	Molykote D321R Molykote M55 Plus
		Emulsion for lubrication of rubber.	P 80
		Protection lubricant emulsion.	KLUBERPLUS S 06/100
		Lubricant for mechanical elements	Castor oil

General maintenance instructions

Useful tips

Ducati recommends you to follow the instructions below in order to prevent problems and obtain the best result:

- when diagnosing faults, primary consideration should always be given to what the customer reports about motorcycle operation since this information can highlight faults; your questions to the customer concerning symptoms of the fault should be aimed at clarifying the problem;
- diagnose the problem systematically and accurately before proceeding further. This manual provides the theoretical background for troubleshooting; this basis must be combined with personal experience and attendance at periodic training courses held by Ducati;
- repair work should be planned carefully in advance to prevent any unnecessary downtime, for example obtaining the required spare parts or preparing the necessary tools, etc.;
- limit the number of operations needed to access the part to be repaired. Note that the disassembly procedures in this manual describe the most efficient way to reach the part to be repaired.

General advice on repair work

- Always use top quality tools. When lifting the motorcycle, only use devices that fully comply with the relevant European directives.
- When working on the motorcycle, always keep the tools within reach, ideally in the order required, and never put them on the motorcycle or in hard-to-reach or inaccessible places.
- The workplace must be kept clean and tidy at all times.
- Always replace gaskets, sealing rings and split pins with new parts.
- When loosening or tightening nuts or screws, always start with the largest or start from the centre; tighten nuts and screws to the specified torque working in a cross pattern.
- Always mark any parts and positions which might easily be confused upon reassembly.
- Use exclusively Ducati original spare parts and the recommended brands of lubricants.
- Use special tools where specified.
- Ducati Technical Bulletins often contain updated versions of the service procedures described in this manual. Check the latest Bulletins for details.

General safety rules

Carbon monoxide

When a maintenance operation must be performed with the engine running, make sure that the working area is well-ventilated. Never run the engine indoors.



Warning

Exhaust gases contain carbon monoxide, which is a poisonous gas that can cause unconsciousness or even death if inhaled.

Run the engine outdoors or, if working indoors, use an exhaust gas extraction system.

Fuel

Always make sure the working area is well ventilated. Keep any sources of ignition, such as cigarettes, open flames or sparks, well away from working area and fuel storage area.



Warning

Fuel is highly flammable and can explode under certain conditions. Keep away from children.

Hot parts



Warning

The engine and exhaust parts become hot when the motorcycle engine is running and will stay hot for some time after the engine has been stopped. Wear heat-resistant gloves before handling these components or allow the engine and exhaust system to cool down before proceeding.



Warning

The exhaust system might be hot, even after engine is switched OFF; pay particular attention not to touch exhaust system with any body part and do not park the motorcycle next to inflammable material (wood, leaves etc.).

Used engine oil



Warning

Prolonged or repeated contact with used engine oil may cause skin cancer. If working with engine oil on a daily basis, we recommend washing your hands thoroughly with soap immediately afterwards. Keep away from children.

Brake dust

Never clean the brake assembly using compressed air or a dry brush.

Brake fluid



Warning

Spilling brake fluid onto plastic, rubber or painted parts of the motorcycle may cause damages. Protect these parts with a clean shop cloth before proceeding to service the system. Keep away from children.

Battery



Warning

The battery gives off explosive gases; never cause sparks or allow naked flames and cigarettes near the battery. When charging the battery, ensure that the working area is properly ventilated.

Identification data

Each Ducati motorcycle has two identification numbers - the frame number and the engine number - and an EC nameplate (A) not present on the U.S.A. version.



Please quote these numbers, which identify the motorcycle model, when ordering spare parts.

DATA STAMPED ON THE FRAME

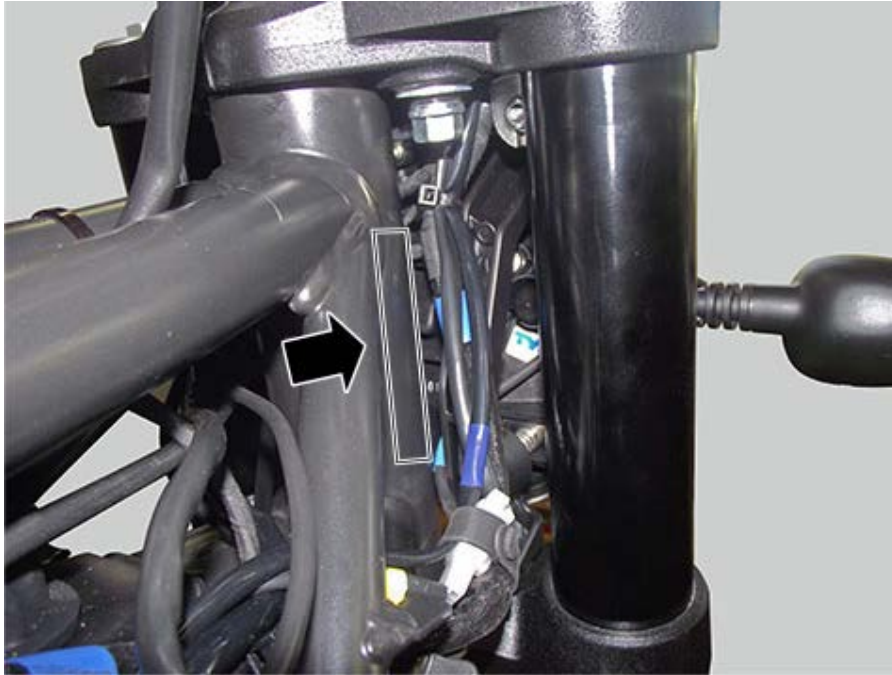

Example: ZDM K 100AA # B ?????

Following is the table with the frame part numbers.

EC Plant Borgo Panigale						
VERSION	1	2	3	4	5	6
EC version frame	ZDM	K	100AA	#	B	?????
JAPAN version frame	ZDM	K	101JA	#	B	?????
EC 35 kW version frame	ZDM	K	102AA	#	B	?????
EC 25 kW version frame	ZDM	K	103AA	#	B	?????
EC Plant THAI version						
EC version frame	MLO	K	100AA	#	T	?????
JAPAN version frame	MLO	K	101JA	#	T	?????

- 1 = Manufacturer: Ducati Motor Holding
- 2 = Type - identical for all models
- 3 = Variant
- 4 = Model Year, E for 2014 models, F for 2015 models, G for 2016 models etc.
- 5 = Manufacturing facility
- 6 = Progressive serial no.

DATA STAMPED ON ENGINE

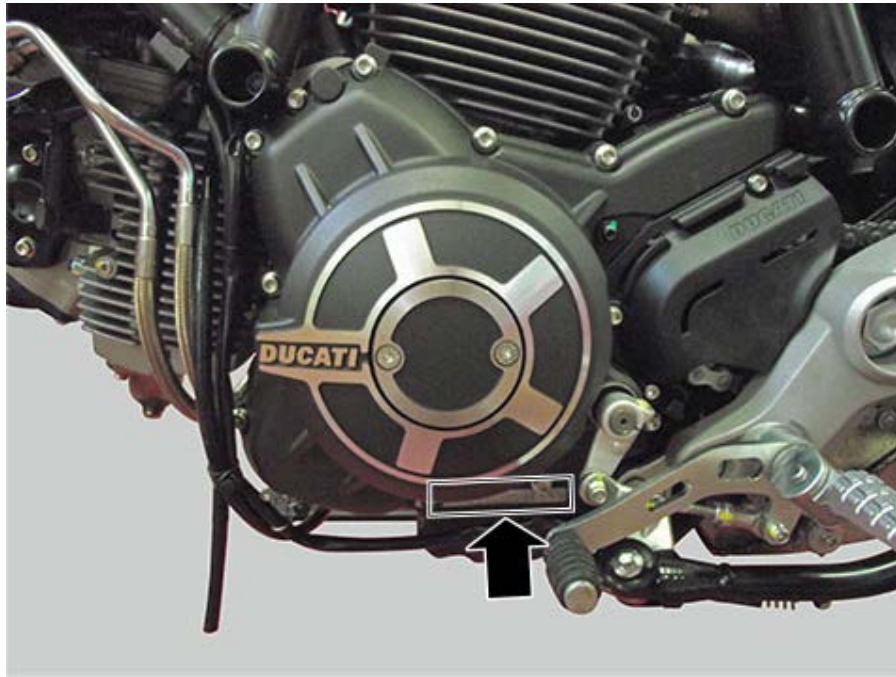

Example: ZDM 800A2C ??????

Following is the table with the engine part numbers.

EC Plant Borgo Panigale			
VERSION	1	2	3
Engine	ZDM	800A2C	?????
Engine	MLO	800A2C	?????
EC Plant THAI version			
Engine	MLO	800A2D	?????
Engine	ZDM	800A2D	?????

1 = Manufacturer

2 = Engine type

3 = Progressive serial no.

Lights/Instrument panel

	Reference	Technical specifications
Headlight		
Headlight	low beam/high beam lamp type	H4 (12V-60/55W)
Parking light	LED	No. 1 LED (3.1W — 13.5V)
Tail light		
Parking light	LED	No. 2 LEDs (3.24W-12V)
Stop light	LED	No. 6 LEDs (7.9W-12V)
Number plate light		
-	lamp	No. 3 LEDs (0.67W-13.5V)
Turn indicators		
Front	lamp	12V RY10W
Rear	lamp	12 VRY10W
Fuses		
1	Key-on	10A
2	El. loads	15A
3	Instrument panel	10A
4	Control unit	5A
5	Injection	20A
6	ABS motor	25A
7	ABS	10A

Fuel system

Important

Do not use any additives in fuel or lubricants. Using them could result in severe damage of the engine and motorcycle components.

Warning

The motorcycle is only compatible with fuel having a maximum content of ethanol of 10% (E10). Using fuel with ethanol content over 10% is forbidden. Using it could result in severe damage to the engine and motorcycle components. Using fuel with ethanol content over 10% will make the warranty null and void.

Make	Type
Unleaded fuel Fuel specifications for the US market.	95-98 RON Unleaded fuel with a minimum octane rating of 90 (RON+MON)/2
Throttle body	Ø 45 mm
Injectors per cylinder	1
Firing points per injector	8

Ignition system

	Reference	Technical specifications
Starting	Type	Electric starter motor 12 V - 0.7 kW
Spark plugs	Make and type	NGK DCPR8E
	Electrode gap	0.7÷0.8 mm

Injection system

	Make	Type
Control unit	-	-

Charging system/generator

	Reference	Technical specifications
Battery	Voltage	12 V
	Charge	10 A/h
	Type	Sealed-type, maintenance-free
Generator	Capacity	490 W - 14 V - 34.8 A

Hydraulic brakes

	Reference	Standard value	Service limit
FRONT			
Brake disc	Type	Drilled disc	
	Thickness	5 mm	
	Flange material	Steel	
	Braking surface material	Stainless steel	
	Diameter	330 mm	
Brake calliper	Make	Brembo	
	Type	M 4.3	
	Calliper cylinder diameter	32 mm	
	Pad friction material	FERIT I/D 450-FF	
Master cylinder	Type	PS 13/22	
REAR			
Brake disc	Type	Fixed drilled disc	
	Thickness	4mm	
	Material	Stainless steel	
	Diameter	245 mm	
Brake calliper	Make	Brembo	
	Type	PF 32	
	Pad friction material	FERIT I/D 450-FF	
Master cylinder	Type	PS 11	
	Master cylinder diameter	11 mm	

Rear suspension

	Reference	Technical specifications
Type		SACHS: monoshock with adjustable preload.
Shock absorber	Wheel travel	150 mm

Rear wheel

	Reference	Standard value	Service limit
Minimum tread depth	In the most worn part		2 mm
Tyre pressure	Cold	2.50 bar (rider only) 2.90 bar (full load)	
Swinging arm shaft runout	On 100 mm		0.2 mm
Wheel rim runout	Radial		1 mm
	Sideways		0.5 mm
Drive chain	Make	DID	
	Type	520 VF	
	No. of links	104	

Front suspension

	Reference	Technical specifications
Type		KAYABA non-adjustable hydraulic upside-down fork Leg Ø 43 mm
	Wheel travel	150 mm
Fork	Oil level per leg	427 cc (right leg) 298 cc (left leg)

Front wheel

	Reference	Standard value	Service limit
Minimum tread depth	In the most worn part		2 mm
Tyre pressure	Cold	2.50 bar (rider only) 2.50 bar (full load)	
Wheel shaft runout	On 100 mm		0.05 mm
Wheel rim runout	Radial		1 mm
	Sideways		0.5 mm
Airgap	Range	1.3÷1.9 mm	

Gearbox

	Reference	Standard value	Service limit
Gearbox shafts	End float		0.05÷0.020 mm
Selector drum	End float		0.10÷0.040 mm
Gear selector fork	Fork slider thickness	3.90÷4.00 mm	n.a.
	Fork-to-gear clearance	0.1 ÷ 0.3 mm	n.a.
	Fork to gear clearance for central slider	0.070÷0.285 mm	0.4 mm

Cylinder/piston

	Reference	Standard value	Service limit
	Cylinder liner nominal diameter	88 mm	
	Max. oval		0.03 mm
	Max. taper		0.03 mm
	Diameter Section A Section B Section C	- 88.000 ÷ 88.010 mm 88.010 ÷ 88.020 mm 88.020 ÷ 88.030 mm	
Piston-to-bore clearance		0.025 ÷ 0.045 mm	
Piston	Nominal diameter	88 mm	
	Diameter Section A Section B Section C	- 87.965 ÷ 87.975 mm 87.975 ÷ 87.985 mm 87.985 ÷ 87.995 mm	
Connecting rod	Connecting-rod big-end diameter	43.67 mm	
Gudgeon pin-to-piston clearance		0.015 ÷ 0.024 mm	
	Nominal diameter	Ø 18 mm	
	Piston	Ø 18 mm / 0.020 ÷ 0.015	
	Gudgeon pin	Ø 18 mm / 0 ÷ 0.004	
Gudgeon pin-to-connecting rod clearance		0.028 ÷ 0.041 mm	
Engine cylinder compression measured with DDS2	Standard	11 ÷ 13 bar	n.a.
	Minimum		10 bar
	Max. allowed difference		2 bar

Crankshaft

	Reference	Standard value	Service limit
Crankshaft	Oval		n.a.
	Taper		n.a.
	Main journals alignment		n.a.
	Crank pin diameter	$\varnothing 40.017 \text{ mm}/\varnothing \pm 0.016 \text{ mm}$	

Timing system/valves

	Reference	Assembly value	Checking clearance upon set mileage (Km 24,000 / mi 15,000)
Timing diagram	With 1 mm valve clearance		
	Intake	Opening 4° B.T.D.C. Closing 66° A.B.D.C.	
	Exhaust	Opening 61° B.B.D.C. Closing 7° A.T.D.C.	
	Intake valve diameter	44 mm	
	Exhaust valve diameter	38.5mm	
Valve lift	With 0 mm valve clearance	Intake 11.20 mm Exhaust 10.80 mm	
	Opening rocker arm - intake	0.10÷0.15 mm	0.10÷0.15 mm
	Opening rocker arm - exhaust	0.10÷0.15 mm	0.10÷0.15 mm
	Closing rocker arm - intake	0÷0.05 mm	0÷0.05 mm
	Closing rocker arm - exhaust	0÷0.05 mm	0÷0.05 mm
		Assembly value (new belt)	Recovery value (used belt)
Cold belt tension adjustment	DDS.2	145±5 Hz (horizontal) 160±5 Hz (vertical)	100±5 Hz (horizontal) 100±5 Hz (vertical)
	Limit value of used belt (when cold)		70 Hz

Transmission

	Reference	Technical specifications
	Clutch	Wet, with mechanical control
	Clutch control	Cable type
	Gearbox	6 speed
	Primary drive	1.85:1
	Final drive	15/46
	Gearbox type	With constant mesh spur gears, operated by a lever on the left side of the motorcycle
Transmission	Gear ratios	
	1st	13/32
	2nd	18/30
	3rd	21/28
	4th	23/26
	5th	22/22
	6th	26/24

Colours

Description	Part no.
ICON	-
'62 Yellow	-
Primer	DS20052 (LECHLER)
Enamel	MC060035 (LECHLER)
Charcoal black frame AKZO NOBEL	MY/ 2/9611AV
Matt Black wheel rims PEHADUR EINBRENN-LACK	VPCH03352 (Peter Lacke)
Ducati Red	-
Primer	2920007 (LECHLER)
Enamel	LMC06017 (LECHLER)
Charcoal black frame AKZO NOBEL	MY/ 2/9611AV
Matt Black wheel rims PEHADUR EINBRENN-LACK	VPCH03352 (Peter Lacke)
URBAN ENDURO	-
Wild Green	-
Primer	DS20054 (LECHLER)
Enamel	MC060013 (LECHLER)
Charcoal black frame AKZO NOBEL	MY/ 2/9611AV
Matt Black wheel rims PEHADUR EINBRENN-LACK	VPCH03352 (Peter Lacke)
FULL THROTTLE	-
Deep Black	-
Primer	88110748 (PALINAL)
Clear-coat	929.R223 (PALINAL)
Clear lacquer	923I.2176 (PALINAL)
Charcoal Black Frame AKZO NOBEL	2/9611AV
Matt Black wheel rims PEHADUR EINBRENN-LACK	VPCH03352 (Peter Lacke)
CLASSIC	-
Orange Sunshine	-
Primer	DS20052 (LECHLER)
Clear-coat	2909041 (LECHLER)
Clear lacquer	96230 (LECHLER)
Charcoal Black Frame AKZO NOBEL	MY/ 2/9611AV
Matt Black wheel rims PEHADUR EINBRENN-LACK	VPCH03352 (Peter Lacke)

General

	Reference	Technical specifications	
Motorcycle dimensions	Total length	2100 ± 20 mm	
	Total length (CLASSIC)	2140 ± 20 mm	
	Total width	855 ± 20 mm	
	Total height	1150 ± 20 mm	
	Total height (FULL THROTTLE)	1104 ± 20 mm	
	Seat height	790 ± 20 mm — lowered seat 770 ± 20 mm	
	Wheelbase	1450 ± 20 mm	
	Frame	Type	Molybdenum-chrome steel tubular trellis
		Steering head angle	24°
Steering angle		35°	
Trail		112 mm	
Front suspension		Kayaba: Non-adjustable 41 mm hydraulic upside-down fork.	
Front wheel travel		150 mm	
Rear suspension		Kayaba: The rear suspension system uses a hydraulic monoshock absorber with adjustable spring preload.	
Front wheel rim		10-spoke, light alloy	
Front rim (URBAN ENDURO - CLASSIC)		Spoked wheels	
Front wheel rim size		MT 3.00x18"	
Front tyre size		110/80 - ZR 18	
Rear wheel rim		10-spoke, light alloy	
Rear rim (URBAN ENDURO - CLASSIC)		Spoked wheels	
Rear wheel rim size	MT 5.50x17"		

	Rear tyre size	180/55 - ZR 17
	Type of tyres	Radial tubeless tyres
	Front brake	Hydraulic, 1 calliper with ABS
	Rear brake	Hydraulic, 1 calliper with ABS
Engine	Type	Longitudinal 90° "L" twin cylinder, four-stroke.
	Bore	88 mm
	Stroke	66 mm
	Displacement	803 cu. cm
	Compression ratio	11±0.5:1
	Timing system	Desmodromic (type) with two valves per cylinder, operated by four rocker arms (2 opening rocker arms and 2 closing rocker arms) and one overhead camshaft. This system is driven by the crankshaft through spur gears, pulleys and toothed belts.
	Lubrication system	Forced by pump
	Oil pump type	Gear type
	Cooling system	Air-type
	Air filter	One filtering element
	Crankshaft type	One-piece

Dimensions



	A	B	C	D	E	F
VERSIONS						
ICON	2100±20 mm	1450±20 mm	170±20 mm	790±20 mm	1150±20 mm	855±20 mm
CLASSIC	2140±20 mm	1450±20 mm	170±20 mm	790±20 mm	1150±20 mm	855±20 mm
URBAN ENDURO	2100±20 mm	1450±20 mm	170±20 mm	790±20 mm	1150±20 mm	855±20 mm
FULL THROTTLE	2100±20 mm	1450±20 mm	170±20 mm	790±20 mm	1104±20 mm	855±20 mm

Fuel, lubricants and other fluids

Warning

Failure to observe weight limits could result in poor handling and impair the performance of your motorcycle, and you may lose control of the motorcycle.

Fuel, lubricants and other fluids	Type	cu. dm(litres)
Fuel tank, including a reserve of 4cu. dm (litres)	Unleaded fuel with 95-98 RON fuel octane rating (at least) For the US market, unleaded fuel with 90 (RON+MON)/2 fuel octane rating (at least).	13.5
Oil sump and filter	SHELL Advance 4T Ultra	3.7cu. dm (litres)
Front/rear brake and clutch circuits	SHELL - Advance Brake DOT 4 special hydraulic fluid	
Protectant for electric contacts	SHELL - Advance Contact Cleaner spray used to protect electric systems	
Front fork	SHELL - Advance Fork 7.5 or Donax TA	RH leg: 427 cc. LH leg: 298 cc.

Important

Do not use any additives in fuel or lubricants. Using them could result in severe damage of the engine and motorcycle components.

Warning

The motorcycle is only compatible with fuel having a maximum content of ethanol of 10% (E10). Using fuel with ethanol content over 10% is forbidden. Using it could result in severe damage to the engine and motorcycle components. Using fuel with ethanol content over 10% will make the warranty null and void.

Engine oil

A good quality engine oil has special properties. Use only a highly detergent engine oil with certified SE, SF or SG or higher service ratings as marked on the container.

Viscosity

SAE 15W-50

The other viscosity grades specified in the table can be used where the average ambient temperatures are within the limits shown.

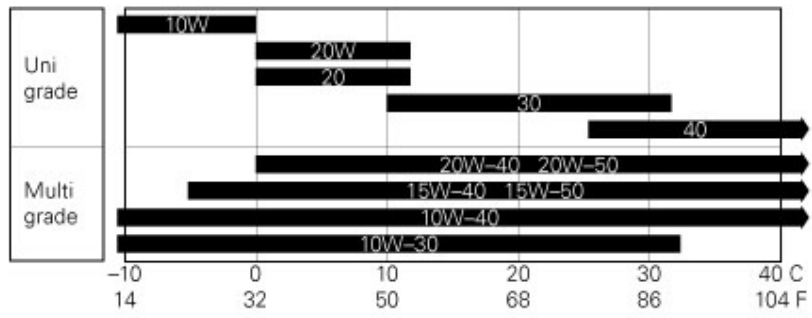

Engine tightening torque values

Description	Thread length	Threading	Torque (Nm)			Notes
			Rated	Min	Max	
Gear selector control						
Gearbox drum positioning screw	-	M16x1.5	27	30	33	
Neutral sensor	-	M10x1.25	9	10	11	
Gearbox pawl screw	25	M8x1.25	34	36	38	Pre-applied threadlocker
Gearbox pawl screw	20	M6x1	15	16	17	Pre-applied threadlocker
Pawl positioner retaining nut	-	M6x1	9	10	11	
Clutch						
Clutch drum nut	-	M25x1.5	180	190	200	GREASE B
Wet clutch spring screw	20	M6x1	9	10	11	
Pistons						
Fixed tensioner assembly	-	M8x1	18	20	22	LOCK 2
Vertical cylinder oil temperature sensor	-	M8x1.25	8.5	9	9.5	
Timing assembly						
Timing layshaft pulley ring nut	-	M15x1	64	71	78	GREASE B
Camshaft gear nut	-	M14x1	50	55	60	GREASE B
MOBILE tensioner retaining screw	-	M8x1.25	23	26	29	
PLASTIC cover retaining screw	30	M6x1	9	10	11	Pre-applied threadlocker
PLASTIC cover retaining screw	18	M6x1	9	10	11	Pre-applied threadlocker
Ignition assembly						
Spark plug	-	M12x1.25	18	20	22	

Screw securing rotor to flywheel	18-25	M6x1	11	13	15	Pre-applied threadlocker
Starter clutch flange retaining screw	16	M6x1	9	10	11	LOCK 5
Connecting rod unit						
Flywheel retaining nut	-	M24x1	313	330	346	LOCK 5
Primary sprocket retaining nut	-	M22x1	171	190	209	GREASE B
Connecting rod screw	-	M10x1				GREASE B
1) Tightening	50 rpm		35			
2) Loosening	2-sec pause		360°			
3) Snug torque	30 rpm		20			
4) Snug torque	10 rpm		35			
5) Tightening	14 rpm		65° ± 1°			
6) Check			70 to 103			
Crankshaft dowel	8	M8x1.25	11	13	15	LOCK 5
Crankshaft drilled dowel	8	M8x1.25	11	13	15	LOCK 5
Covers						
Wet clutch fluid filler cap	-	M20x2.5	4.5	5	5.5	
Soundproofing panel retaining central screw	-	M14x1.5	22	24	26	LOCK 5
Pick-up + washer inspection screw	-	M12x1	13	15	17	LOCK 2
Oil duct blanking plug + washer	-	M10x1	13.5	15	16.5	LOCK 5
Timing inspection cover screw	14	M6x1	4.5	5	5.5	
Alternator cover closing screw	20-25-30-35	M6x1	12.5	13.5	14.5	
Stator retaining screw	40	M6x1	9	10	11	LOCK 2

Clutch cover closing screw	30-80-90	M6x1	12.5	13.5	14.5	
Special screw securing generator cover to stud bolt	30-35	M6x1	12.5	13.5	14.5	
Screw securing pushrod plug on generator cover	12	M6x1	9	10	11	

Frame tightening torque values

Description	Threading	Nm \pm 10% Tolerance	Notes
Stand			
Side stand rotation pin lock nut fastener	M10x1.25	24	
Side stand plate to crankcase fastener	M10x1.5	36	Pre-applied threadlocker
Stand sensor fastener	M6x1	5	Pre-applied threadlocker
Side stand rotation pin fastener	M10x1.25	35	
Chain and front sprocket			
Sprocket fastener	M5x0.8	6*	Pre-applied threadlocker
Sprocket cover fastener	M6x1	6	Pre-applied threadlocker
Headlight fairing			
LH rear-view mirror retainer	M8x1.25	25	Pre-applied threadlocker
RH rear-view mirror retainer	M8x1.25	25	Pre-applied threadlocker
Lights			
Headlight to U-bolt support fastener	M5x0.8	5	Pre-applied threadlocker
Headlight subframe puffer to steering plate fastener	M6x1	8	
Headlight support to bottom yoke retainer	M6x1	8	
Front turn indicators to headlight support fastener	M6x1	8	
Instrument panel			
Instrument panel to support fastener	M5x0.8	5	
Instrument panel cover to support fastener	M5x0.8	5	
Front fork			
Steering bearing fastener	M35x1	30*	GREASE B
Brake hose cable ring to bottom yoke fastener	M6x1	8	Pre-applied threadlocker
Steering head to pin central fastener	M8x1.25	24*	GREASE B
Steering head to fork fastener	M8x1.25	24*	GREASE B
Bottom yoke to fork fastener	M8x1.25	18*	GREASE B
Fork bottom end fastener	M6x1	10*	GREASE B
Handlebar lower U-bolt to steering head fastener	M10x1.25	45*	
Headlight support plate to steering head fastener	M6x1	10	Pre-applied threadlocker
Steering lock key fastener	M8x1.25	24	
Leg cover fastener	M5x0.8	5	Pre-applied threadlocker

Electrical and electronic system			
Coil to frame fastener	M5x0.8	5	
RH/LH switch fastener	M5x0.8	1.5	
Battery cable to terminal fastener	M6x1	10	
Solenoid starter cable to starter motor fastener	M6x1	5	GREASE D
Battery cables/starter motor to solenoid starter fastener	M6x1	5	
Technical compartment to frame fastener	M6x1	5	
Control unit to puffer frame fastener			
Ground cable on engine fastener	M6x1	10	
Relay support to technical compartment fastener	M4	1.5	
ABS control unit to technical compartment fastener	M6x1	6.8	
ABS sensor fastener (FRONT+REAR)	M6x1	7	
ABS control unit bracket to airbox fastener	M6x1	10	
Fuse bracket fastener	M4	1.5	
Voltage regulator to airbox cover fastener	M6x1	10	
Tail light fastener	M5x0.8	5	
Braking system: front			
Front brake master cylinder to handlebar fastener	M6x1	10	Sequence 1-(UP)-2-1
Union on LH brake calliper fastener	M10x1	23	
Front LH brake calliper fastener	M10x1.25	45*	GREASE B
Front brake calliper pre-tightening for settling	M10x1.25	2	GREASE B
Union on brake master cylinder fastener	M10x1	23	
Unions to ABS control unit fastener	M10x1	23	
LH brake calliper bleeder fastener	M6x1	4	
Rear swinging arm			
Chain sliding shoe fastener	M5x0.8	5	Pre-applied threadlocker
Chain tensioning slider adjuster fastener	M8x1.25	10	GREASE B
Swinging arm shaft fastener (key)	M8x1.25	18*	GREASE B
Number plate holder subframe fastener	M8x1.25	22	
Hose clip to swinging arm fastener	M5x0.8	5	Pre-applied threadlocker
Australia chain cover to chain sliding shoe fastener	M5	1.2	AUSTRALIA version
Rear brake			

Brake hose unions to brake master cylinder/calliper fastener	M10x1	23	
Rear brake fluid reservoir to frame fastener	M6x1	5	Pre-applied threadlocker
Pre-applied threadlocker	M6x1	10	Pre-applied threadlocker
Rear brake hose guide to swinging arm fastener	M5x0.8	5	Pre-applied threadlocker
Number plate holder			
Number plate holder plate to subframe fastener	M6x1	5	
Reflector fastener	M4x0.7	2	
Number plate light fastener	M4x0.7	1.5	
Front number plate to bracket fastener	M6x1	5	CHINA version
Rear number plate to number plate holder fastener	M6x1	5	CHINA version
Rear number plate to number plate holder fastener	M5x0.8	4	BRAZIL version
Splash guard/number plate holder plate to rear guard fastener	M6x1	5	Pre-applied threadlocker AUSTRALIA version
Gravel guard fastener	M5x0.8	-	AUSTRALIA version
Splash guard/number plate holder plate to rear guard fastener	M6x1	-	AUSTRALIA version
Handlebar - clutch control			
Handlebar U-bolt fastener	M8x1.25	22*	GREASE B
Clutch lever to handlebar fastener	M6x1	10	
Throttle to handlebar fastener	M6x1	6	
Throttle cover fastener	M4x0.7	1.8	
Rear suspension			
Shock absorber to fork fastener	M10x1.25	22*	GREASE B
Shock absorber to rear swinging arm fastener	M10x1.25	42*	GREASE B
Front mudguard			
Front mudguard fastener	M6x1	8	Pre-applied threadlocker
Footpegs and levers: brake side			
Footpeg to footpeg holder plate fastener	M8x1.25	22*	
Rear brake lever adjusting screw fastener	M6x1	5	
Brake master cylinder control rod retainer	M6x1	7.5	
RH footpeg support to engine lower fasteners	M10x1.5	36	
RH footpeg support to swingarm shaft upper fastener	M12x1.25	55*	GREASE B
Stop warning light switch fastener	M8x1	5	LOCK 1





Footpegs and levers: gearbox side			
Joint RH nut to gearbox rod fastener	M6x1	5	LOCK 2
Footpeg to footpeg holder plate fastener	M8x1.25	22*	
LH footpeg support to engine with stand front fastener	M10x1.25	36	
LH footpeg support to engine rear fastener	M10x1.25	36	
LH footpeg support to swingarm shaft upper fastener	M12x1.25	55*	GREASE B
Joint LH nut to gearbox rod fastener	M6x1	5	LOCK 2
Gearchange rod joints to gear shift lever / connecting rod fastener	M6x1	10	
Gearchange lever (connecting rod) to pawl fastener	M6x1	10	LOCK 1
Rear mudguard			
Rear turn indicators to rear guard fastener	M6x1	5	
Upper mudguard to frame fastener	M5	5	
Lower to upper mudguard fastener	M5	5	
Mudguard sub-group to frame fastener	M6x1	8	
Front wheel			
Brake disc fastener	M8x1.25	30	Pre-applied threadlocker
Front wheel nut fastener	M25x1.25	63*	GREASE B
Rear wheel			
Brake disc / phonic wheel fastener	M8x1.25	25	Pre-applied threadlocker
Rear sprocket retainer	M10x1.25	46*	LOCK 2
Pin on rear sprocket flange fastener	M14x1.5	46*	LOCK 8
Rear wheel shaft nut fastener	M25x1.25	145*	GREASE B
Pre-tightening of wheel shaft nut for chain tensioning	M25x1.25	10	
Brake disc retaining screw	M8x1.25	25*	Pre-applied threadlocker
Fuel tank			
GAC flange to tank fastener	M5x0.8	5	
Tank plug fastener	M5x0.8	5	
Front tank silent block nipple fastener	M5x0.8	5	
Tank side covers to tank fastener	M5x0.8	5	
Exhaust			
Exhaust pipe flange to hor./vert. head fastener	M8x1.25	24	Seq.: (1) to 6 Nm - (2) to 24 Nm - (3) to 24 Nm

Stainless steel plugs on exhaust pipes fastener	M10x1.25	25	
Rear heat guard to silencer fastener	M5x0.8	5	Pre-applied threadlocker
Lambda sensor (HOR.+VER.) fastener	M18x1.5	45	
Heat guard to horizontal exhaust fastener	M6x1	8	Pre-applied threadlocker
Horizontal heat guard plastic cover fastener	M5x0.8	5	
Silencer front heat guard fastener	M5x0.8	5	Pre-applied threadlocker
Silencer rear heat guard fastener	M5x0.8	5	Pre-applied threadlocker
Silencer to RH connecting rod fastener	M6x1	10	
Silencer to LH connecting rod fastener	M6x1	10	
RH footpeg holder plate connecting rod fastener	M6x1		
LH footpeg holder plate connecting rod fastener	M6x1		
Frame			
Frame/subframe to engine fastener	M12x1.25	60*	GREASE B
Horn support bracket to frame fastener	M6x1	10	LOCK 2
Tank to bracket on the frame rear fastener	M6x1	10	
Glove box under the seat fastener	M5x0.8	5	
Latch to frame fastener	M5x0.8	5	
Rear shock absorber fork to frame fastener	M10x1.25	42*	GREASE B
Oil cooler			
Cooler fastener	M6x1	10	
Oil hose metallic clip fastener	M6x1	10	
Oil cooler nipple to cooler fastener	M14x1.5	23	LOCK 1
Fastener retaining oil hose coupling on cooler nipple with double O-ring	M16x1.5	18*	Lubricate with engine oil
Fastener retaining oil hose coupling on casing nipple with double O-ring	M16x1.5	25*	Lubricate with engine oil
Air inlet - oil breather			
Filter cover to airbox fastener	4	1	
Airbox to frame fastener	M6x1	10	
Blow-by valve hose to airbox fastening clip	-	1.5	
Airbox filter support	M5x0.8	5	LOCK 6
Blow-by reservoir to airbox fastener	M5x0.8	3	
Fuel system			
Temperature sensor to airbox fastener	M3	1.0	
Hoses to throttle body fastener	-	3	

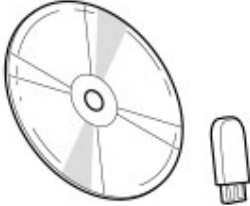

Throttle body to intake funnel fastening clip	-	1.5	
Injector BING caps on manifold	M5x0.8	5	
Canister bracket to engine fastener	M6x1	8	USA version
Fairings			
Central side body panel bracket to RH + LH frame fastener	M5x0.8	5	
Central side body panels to bracket fastener	M5x0.8	5	
Rear RH side body panel to frame fastener (upper screw)	M6x1	8	
Rear LH side body panels to frame fastener (upper screw)	M5x0.8	5	
Rear lower cover to frame fastener	M6x1	8	
Rear lower cover to side body panels fastener	M5x0.8	5	
Front side body panels to airbox cover fastener	M5x0.8	5	
Front side body panels to frame fastener	M6x1	8	
Front tank cover fastener	M5x0.8	5	

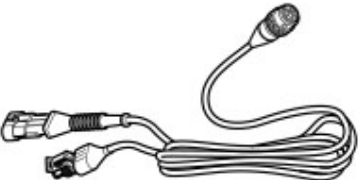
*dynamic safety-critical point; tightening torque tolerance must be Nm \pm 5%.

Diagnosis special tools

PART NO.	DESCRIPTION	IMAGE
28620441A	"PC HASP DDS2.0" wrench	
979000252	DDS 2 (Ducati Diagnosis System 2.0)	
979000253	Belt tensioning	
979000254	Diagnosis and power supply cable	
979000255	Diagnosis and power supply cable (CAN)	
979000256	Power supply cable from DDS battery	

Frame special tools

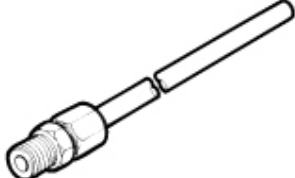
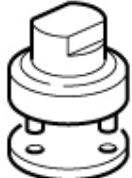
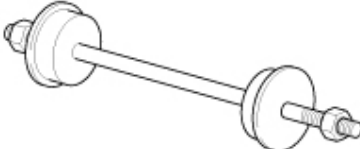
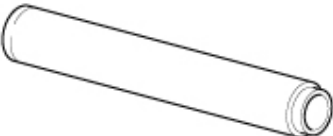



PART NO.	DESCRIPTION	IMAGE
80007.0139	Front wheel shaft wrench	
88713.2562	Chain installation tool	
88713.0958	Rotation bar for fork overhaul	
88713.1010	Exhaust gas suction fitting	
88713.1058	Wrench to fit steering tube	
88713.1062	Steering tube bearing installation tool	
88713.1072	Big end bearing driving tool	

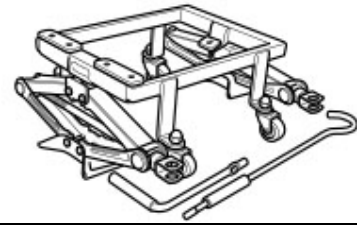

88713.3220

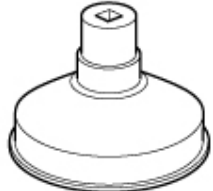
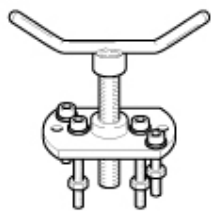
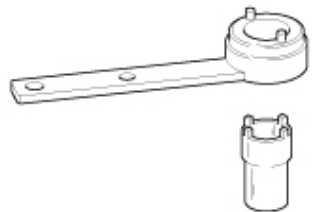

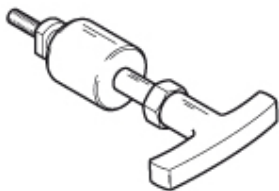

Engine repair work bench

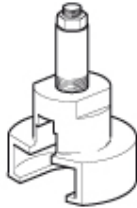
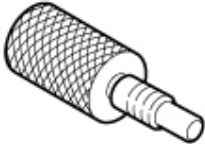
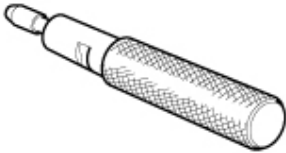

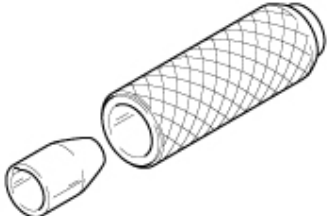
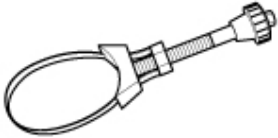
Engine special tools

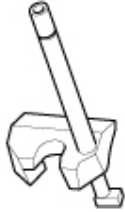
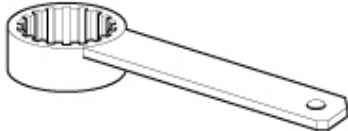
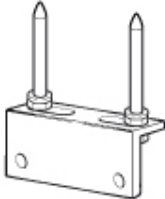
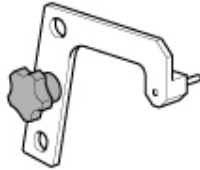
PART NO.	DESCRIPTION	IMAGE
88713.0137	Primary drive sprocket retainer key	
88713.0944	Oil cartridge wrench	
88713.1749	Puller for driving pulley and cover	
88713.1805	Driving pulley tightening tool	
88713.1832	Engine repair work bench	
88713.1994	Rocker arm shaft puller	
88713.2011	Tool to block crankshaft at Top Dead Centre (TDC)	

88713.2092	Primary drive gear puller	
88713.2282	2-valve cylinder head pulley positioning tool	
88713.2442	Tool to install seal ring on valve guide	
88713.2556	Clutch housing reaction tool	
88713.2676	Cylinder head nut tightening tool	
88713.2834	Snap ring installation tool	
88713.2906	Oil cartridge wrench	
88713.2916	Spring and rocker arm installation tool	

		
88713.3218	Pulley ring nut locking wrench	
88713.2103	Bearing surface for head installation	
88713.3334	Selector fork positioning plate	
88713.3367	Flywheel wrench	
88765.1000 88765.1005 88765.1006	Fork feeler gauges	
88765.1298	Valve lower shim check spacer	
88765.1581	Valve lift gauge	

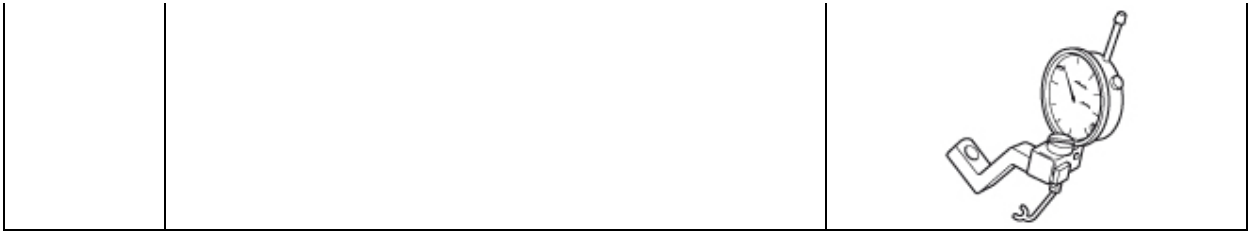

Vehicle pre-delivery

- Transport packaging integrity visual check (where applicable).
- Transport packaging removal (where applicable).
- Motorbike integrity visual check.
- Check of the supplied kit completeness (refer to the parts list supplied together with the kit).
- Rear-view mirror assembly ([Refitting the rear-view mirrors](#)).
- Battery start-up ([Recharging the battery- Topping up the electrolyte](#)) and fitting on the vehicle ([Refitting the battery](#));
- Final drive correct tensioning check.
- Tyre pressure check (Front 2.5 bar - 2.6 bar with passenger / Rear 2.5 bar - 2.8 bar with passenger).
- Check brake fluid level (top up, if necessary).
- Check engine oil level (top up, if necessary).
- Lights, turn indicators, horn and controls check. Headlight beam height adjustment check. Check handlebar free movement and possible interference.
- Check key and steering lock operation.
- Check front and rear wheel shaft tightening (front: 63 Nm \pm 5% - Rear: 145 Nm \pm 10%).
- Check the brake calliper retaining screws tightening (front: 45 Nm \pm 5% - Rear: 14 Nm \pm 5%).
- Fuel top-up until the reserve warning light turns off (approx. 3 litres).
- Check engine stop switch, side stand switch and clutch lever operation.
- Check the presence of any technical updates and recall campaigns on DCS.
- Install any Ducati Performance accessories required by Customer's order and check their operation.
- Final test and road test of the motorcycle (test correct operation of safety devices and electric fan).
- Reading of the error memory with DDS 2.0 and check of software version update on control units (use the Global Scan function).
- Motorcycle cleaning.
- Motorcycle warranty activation and on-board documentation filling in (General warranty conditions).
- Turn in to Customer the documentation and the Service Booklet (appropriately filled in).

Scheduled maintenance chart: operations to be carried out by the customer

List of operations and type of intervention [set mileage (km/mi) or time interval*]	km. x1000	1
	mi. x1000	0.6
	Months	6
Check engine oil level		•
Check brake fluid level		•
Check tyre pressure and wear		•
Check final drive chain tension and lubrication		•
Check brake pads.		•

*Service operation to be carried out in accordance with the specified distance or time intervals (km, miles or months), whichever occurs first.

Scheduled maintenance chart: operations to be carried out by the dealer

List of operations and type of intervention	km x 1000	1	12	24	36	48	Time Months
	mi x 1000	0.6	7.5	15	22.5	30	
Reading of the error memory with DDS and check of software version update on control units		•	•	•	•	•	12
Check the presence of any technical updates and recall campaigns		•	•	•	•	•	12
Change engine oil and filter		•	•	•	•	•	12
Clean the engine oil mesh filter assembly		•					-
Check and/or adjust valve clearance			•	•	•	•	-
Change timing belts				•		•	60
Change spark plugs				•		•	-
Clean air filter			•		•		-
Change air filter				•		•	-
Check brake fluid level		•	•	•	•	•	12
Change brake fluid							36
Check brake disc and pad wear. Change, if necessary		•	•	•	•	•	12
Check the proper tightening of brake calliper bolts and brake disc flange screws		•	•	•	•	•	12
Check front and rear wheel nuts tightening		•	•	•	•	•	12
Check frame-to-engine fasteners tightening			•	•	•	•	-
Check wheel hub bearings				•		•	-
Check and lubricate the rear wheel shaft				•		•	-
Check the cush drive damper on rear sprocket				•		•	-
Check the proper tightening of final drive front and rear sprocket nuts		•	•	•	•	•	12
Check final drive (chain, front and rear sprocket) and sliding shoe wear			•	•	•	•	12
Check final drive chain tension and lubrication		•	•	•	•	•	12
Check steering bearings and lubricate, if necessary				•		•	-
Change front fork fluid					•		-
Visually check the front fork and rear shock absorber seals		•	•	•	•	•	12
Check the freedom of movement and tightening of the side and central stand (if any)		•	•	•	•	•	12
Visually check the fuel lines			•	•	•	•	12
Check rubbing points, clearance, freedom of movement and positioning of hoses and electric wiring in view		•	•	•	•	•	12
Lubricate the levers at the handlebar and pedal controls			•	•	•	•	12

Check tyre pressure and wear	•	•	•	•	•	12
Check the battery charge level	•	•	•	•	•	12
Check secondary air system operation		•	•	•	•	-
Check the operation of the safety electrical devices (side stand sensor, front and rear brake switches, engine stop switch, gear/neutral sensor)	•	•	•	•	•	12
Check lighting, turn indicators, horn and controls	•	•	•	•	•	12
Reset the Service indication through the DDS	•	•	•	•	•	-
Final test and road test of the motorcycle, testing safety devices (ex. ABS) and idling	•	•	•	•	•	12
Softly clean the motorcycle	•	•	•	•	•	12
Fill out that the service was performed in on-board documentation (Service Booklet)	•	•	•	•	•	12
Check spoked wheels as specified in the workshop manual	•	•	•	•	•	-

* Service operation to be carried out in accordance with the specified distance or time intervals (km, miles or months), whichever occurs first

Adjusting the rear shock absorber

The only possible adjustment on the rear shock absorber is spring preload.

Turn adjuster (1) using the suitable wrench to set.

Turn adjuster clockwise to decrease spring preload, turn counter clockwise to increase preload.

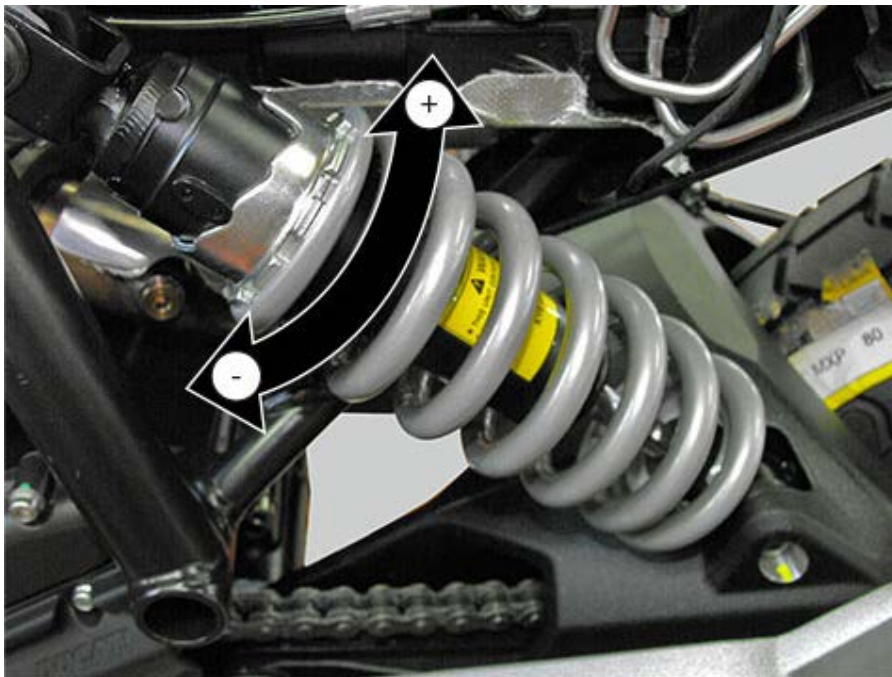
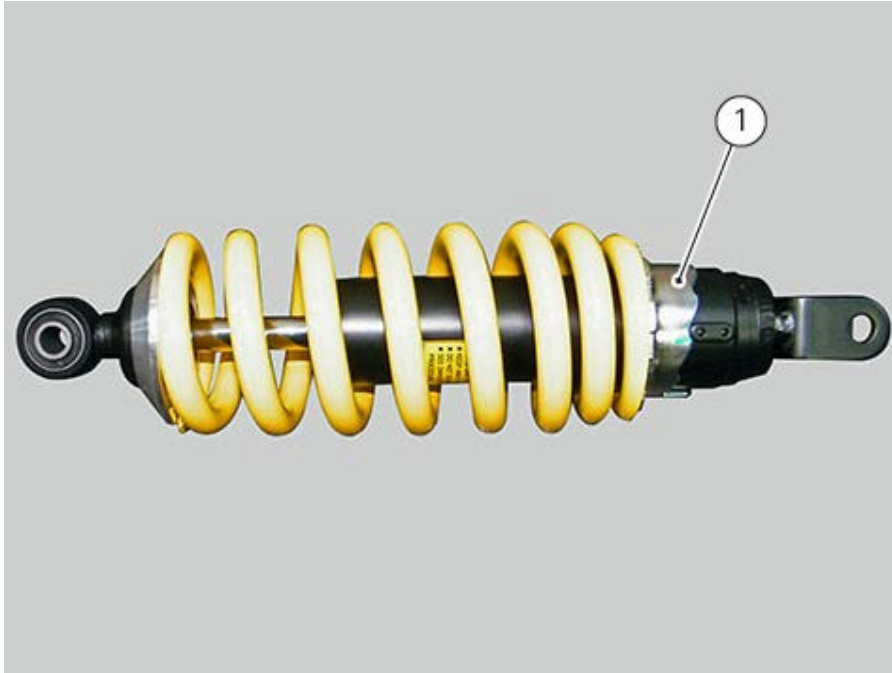

Adjusting the position of the gearchange pedal and rear brake pedal

The position of the gear change and rear brake pedals in relation to the footpegs can be adjusted to suit the preferred riding position.

To adjust the position of the gearchange pedal, proceed as follows.
hold the linkage (1) and slacken the counter nuts (2) and (3).

Fit an open-end wrench to hexagonal element of linkage (1) and rotate until setting pedal in the desired position.

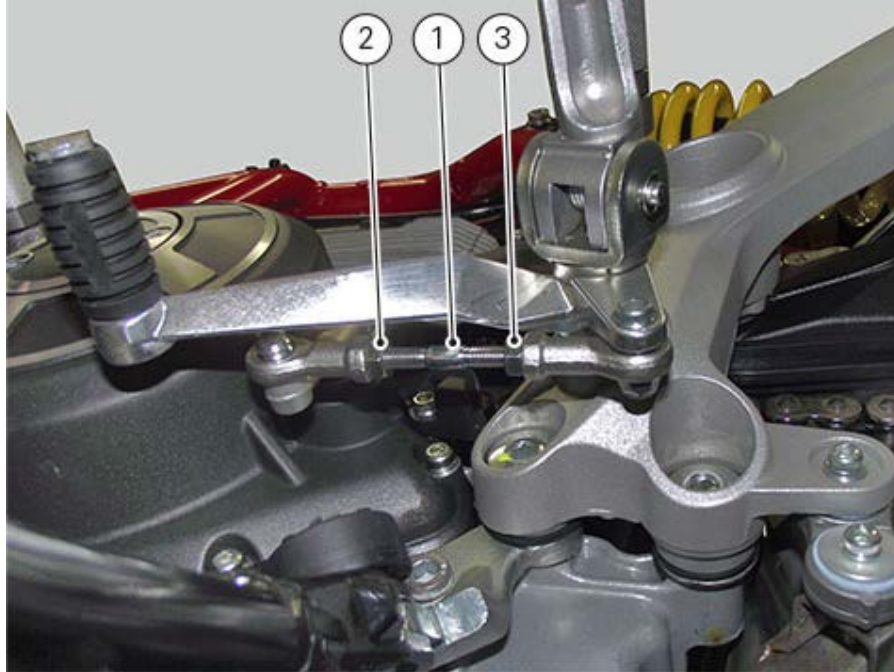

Adjusting the front brake control lever

Pull in the lever (1) towards the throttle twistgrip to operate the front brake. The system is hydraulically operated and you just need to pull the lever gently. The brake lever has an adjuster (2) for adjusting the distance between lever and the handlebar.

To adjust it, keep lever (1) fully extended, and turn adjuster (2), turning it in correspondence of one of the four foreseen positions.

Position 1 corresponds to maximum distance between brake lever and handlebar, while position 4 corresponds to minimum distance.

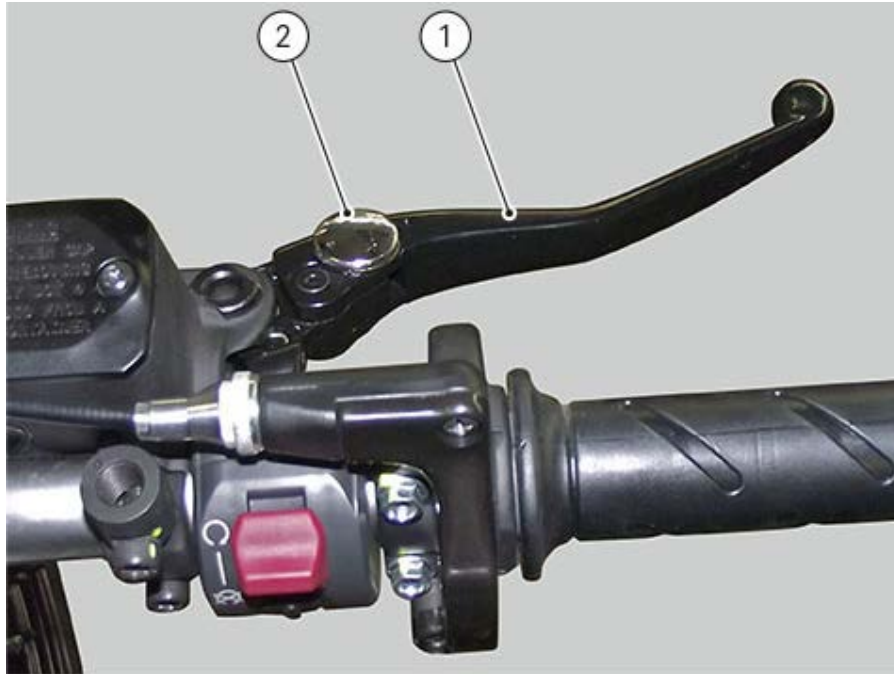

Adjusting the throttle cable

The throttle grip in all steering positions must have 2 to 4 mm of free play. To adjust, work the relevant adjuster (1) located on the control itself.

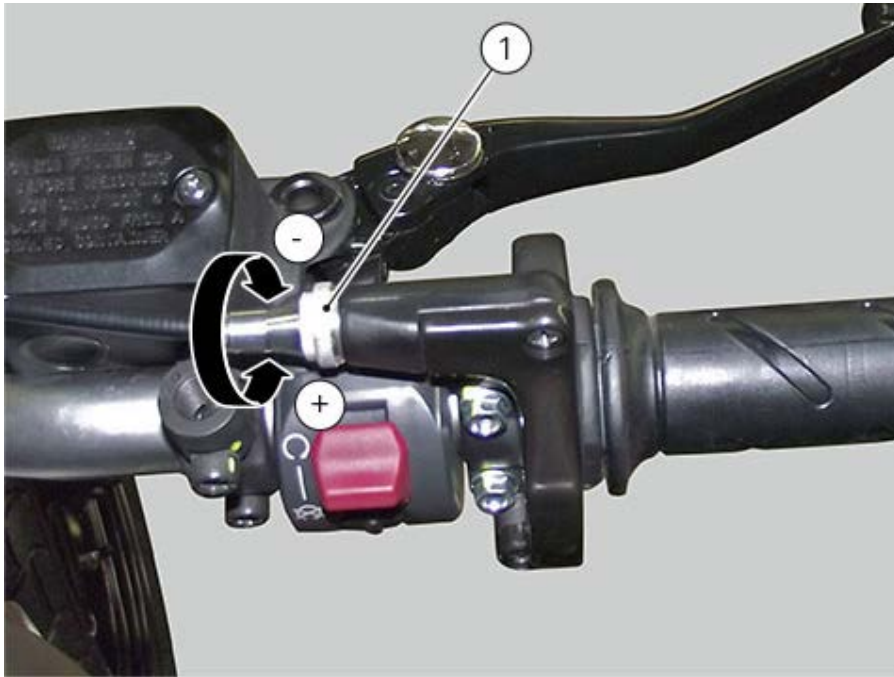

Check the outer sheath of the throttle control cable for damage at regular intervals. The plastic covering should show no signs of pinching or cracking. Lubricate the ends of Bowden cables with the specified grease periodically to ensure they run freely. Operate the control to check that the inner cable slides smoothly inside the outer cable: if you feel excessive resistance or stiffness, replace the cable. To lubricate the throttle control you need to loosen the two retaining screws (3) and remove cover (2).

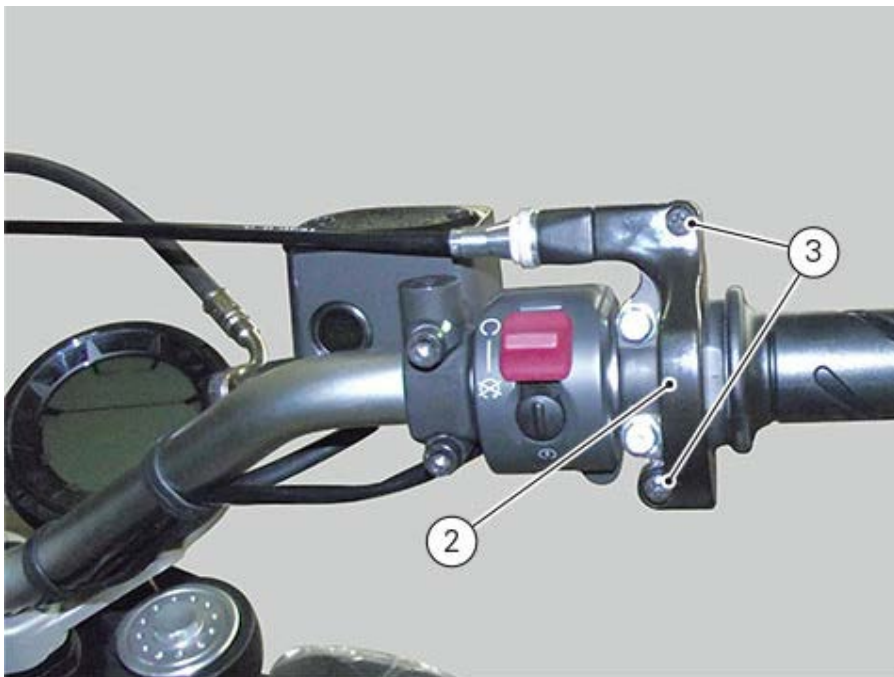

Grease cable end (4) and pulley.

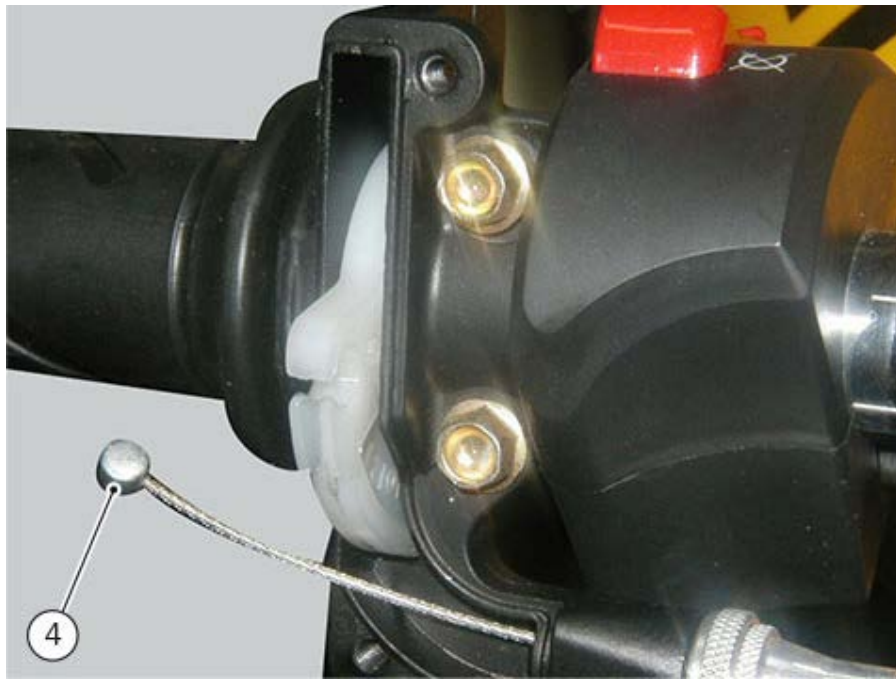

Carefully close the control while engaging cable (4) into slide (5) on cover (2).
Fasten cover and tighten two screws (3) to the torque of $1.8 \text{ Nm} \pm 10\%$.

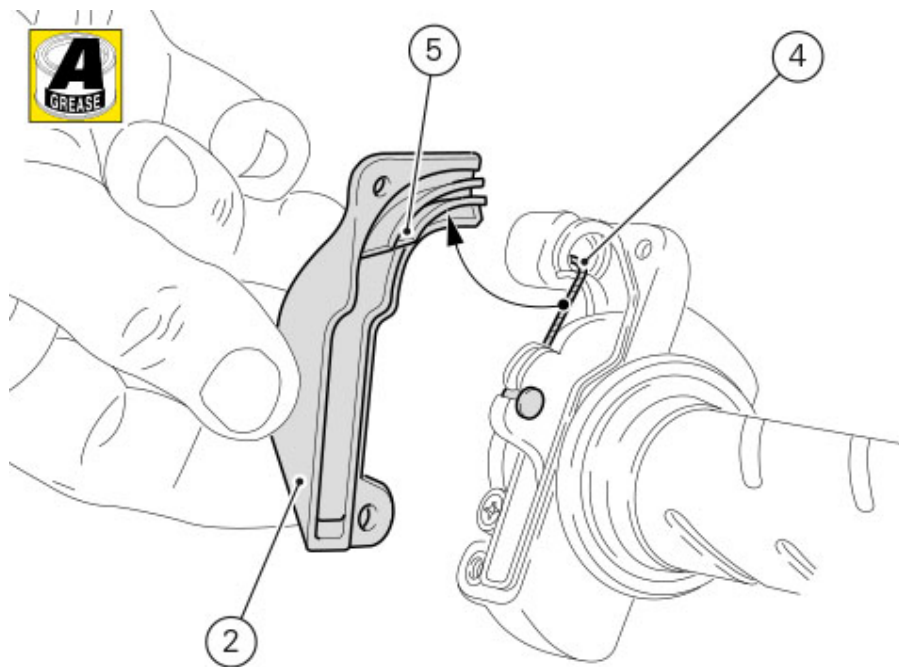

Checking rear brake pad wear and replacing brake pads

Check through the slot between the two calliper halves, and make sure that at least 1 mm of the friction material on pads is visible.

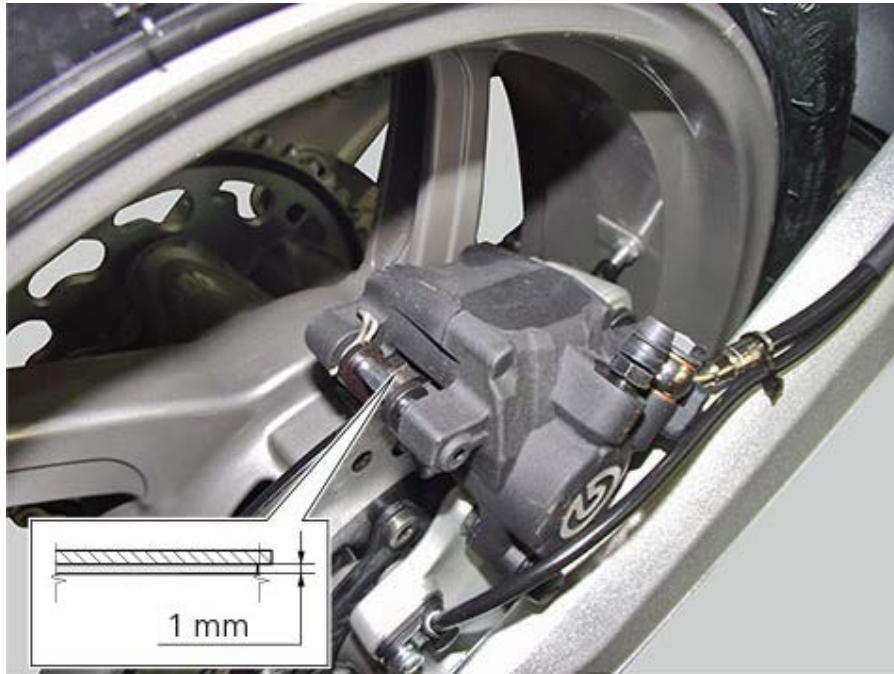

Important

Change both pads even if just one of them is worn.

Change the brake pads as follows.

Remove the snap ring (7) from the pad retaining pin.

Force the calliper pistons back into their seats by forcing the old brake pads apart.

Slide pad retaining pin (8) outwards.

Remove the worn pads.



Fit the new pads.
Fit the centring pin (8) and fasten it with the snap ring (7).



Note

Change pads that have a shiny or "vitrified" appearance.

Operate the brake pedal repeatedly so that the pads firmly bed in against the disc thanks to the brake fluid pressure.

Check that the fluid level inside reservoir is between the MIN and MAX marks.

If this is not the case, unscrew the reservoir cover and top up.

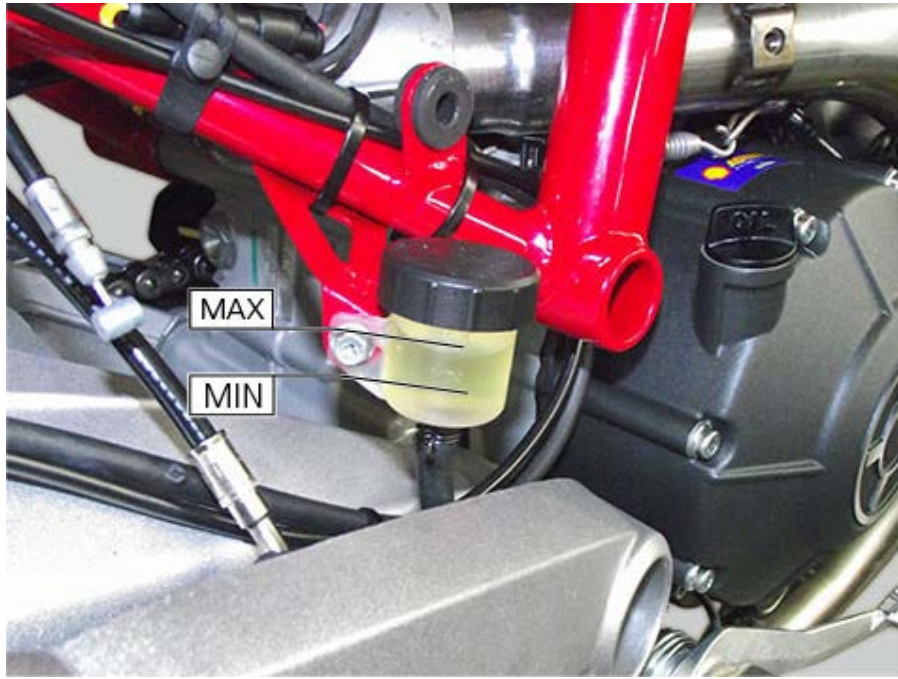

Checking front brake pad wear and replacing brake pads

Warning

Brake fluid is corrosive and will damage paint. Avoid contact with eyes and skin. In case of accidental contact, wash thoroughly with water.

Important

On handing over the motorcycle after changing the brake pads, inform the Customer that the front brake must be used gently for the first 100 km to allow the pads to bed in completely.

Ensure the notch on pad (1) friction surface is visible.

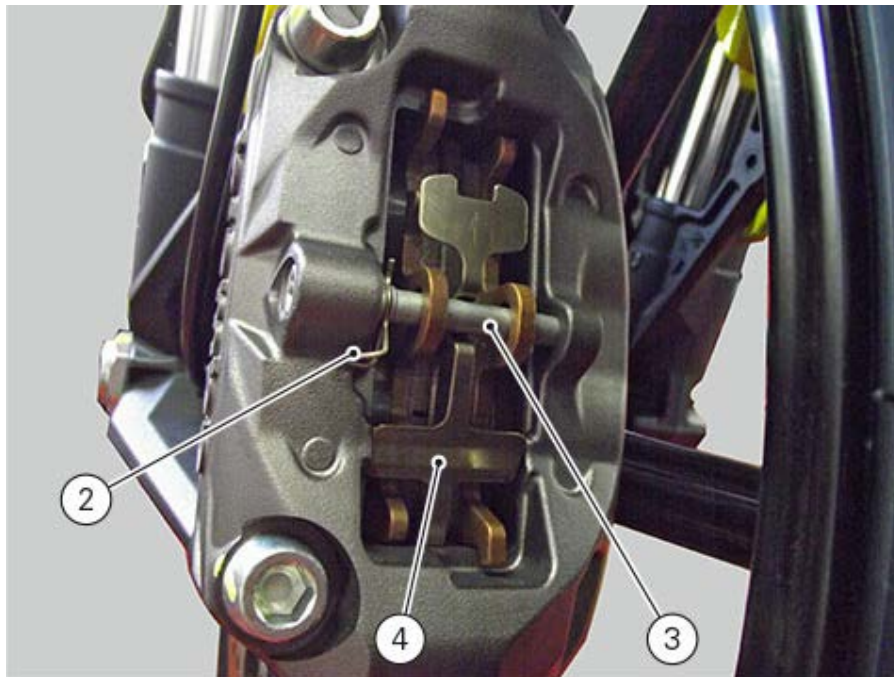
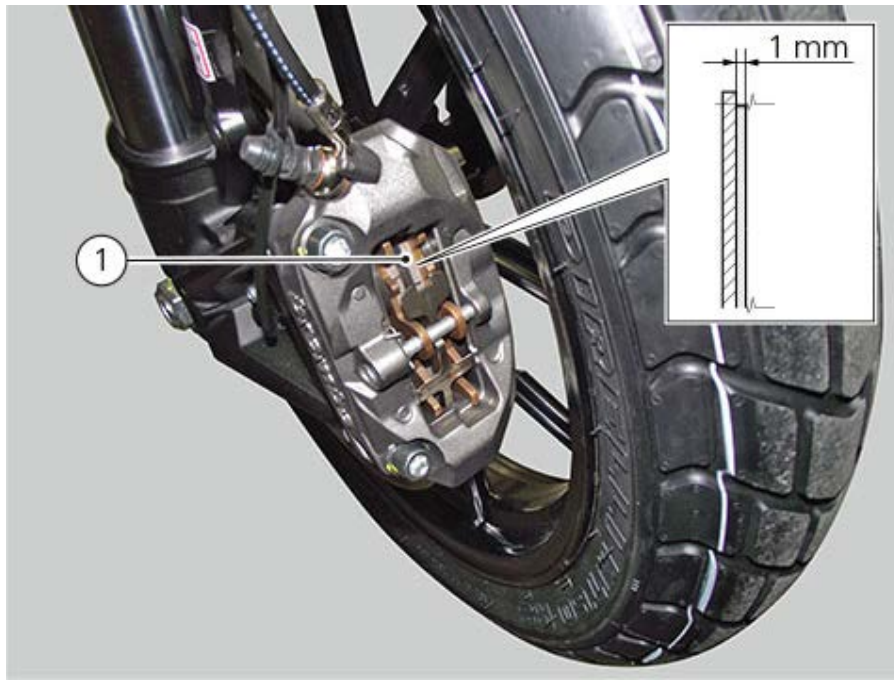

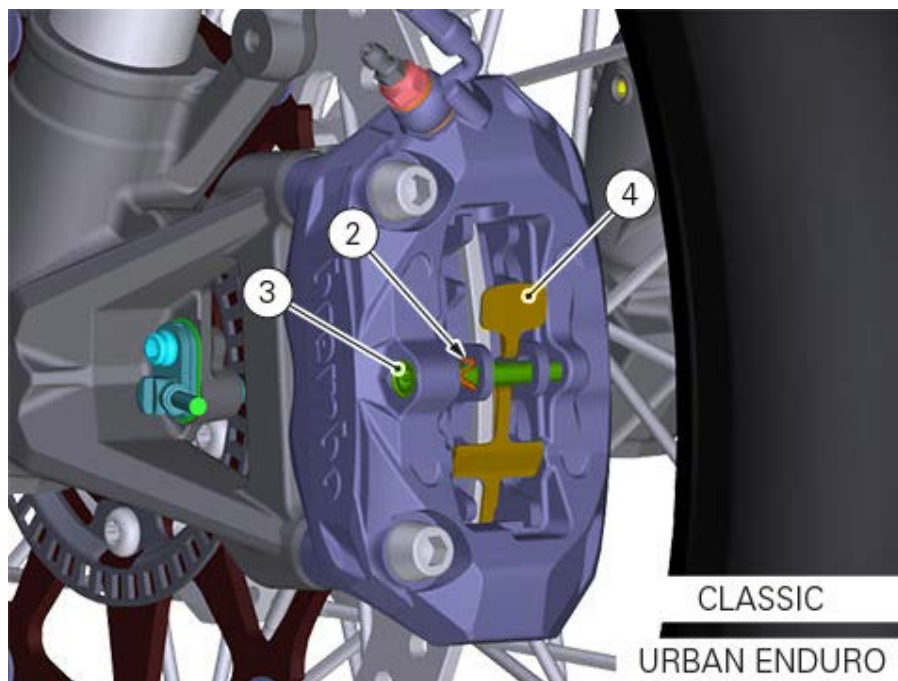
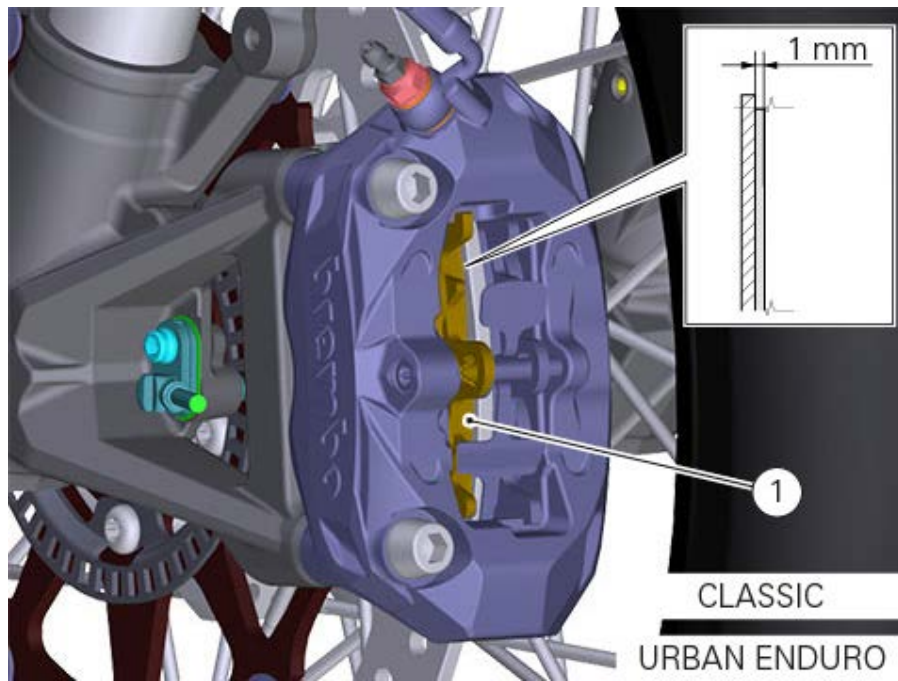

Important

Change both pads even if just one of them is worn.

Change the brake pads as follows.

Remove split pin (2) from the pad retaining pins. Force the calliper pistons back into their seats by forcing the old brake pads apart.

Slide pad retaining pin (3) outwards.

Remove pad retaining clip (4) from between the two calliper halves.

Remove the worn pads (1).

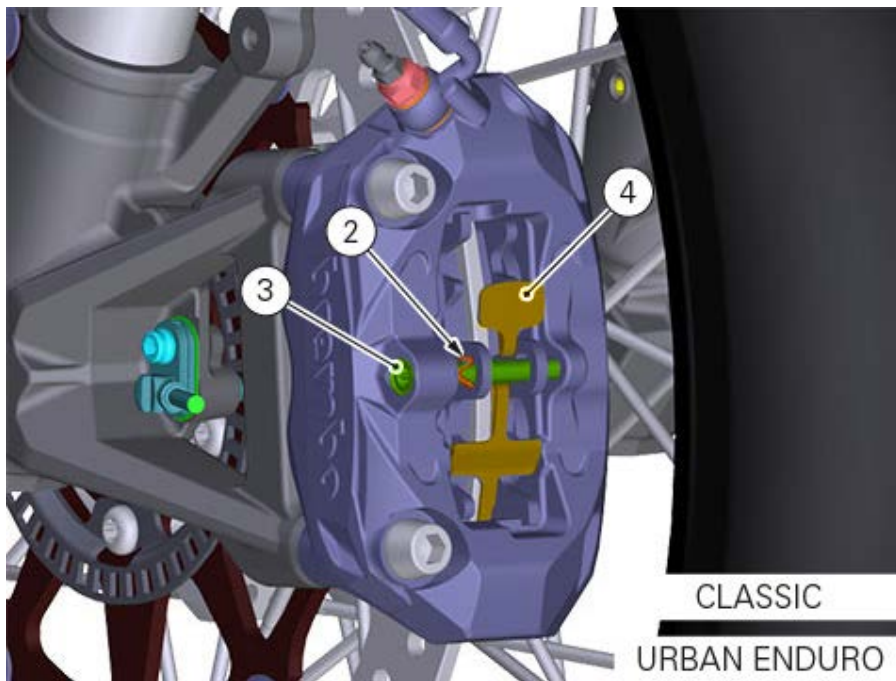

⚠ Warning

Change worn pads of pads that have a shiny or "vitrified" appearance.

Insert new pads and spring (4). Fit the centring pin (3) and fasten it with safety split pin (2).

Pay utmost attention to spring (4) aiming, arrow must be pointing to wheel direction of rotation.

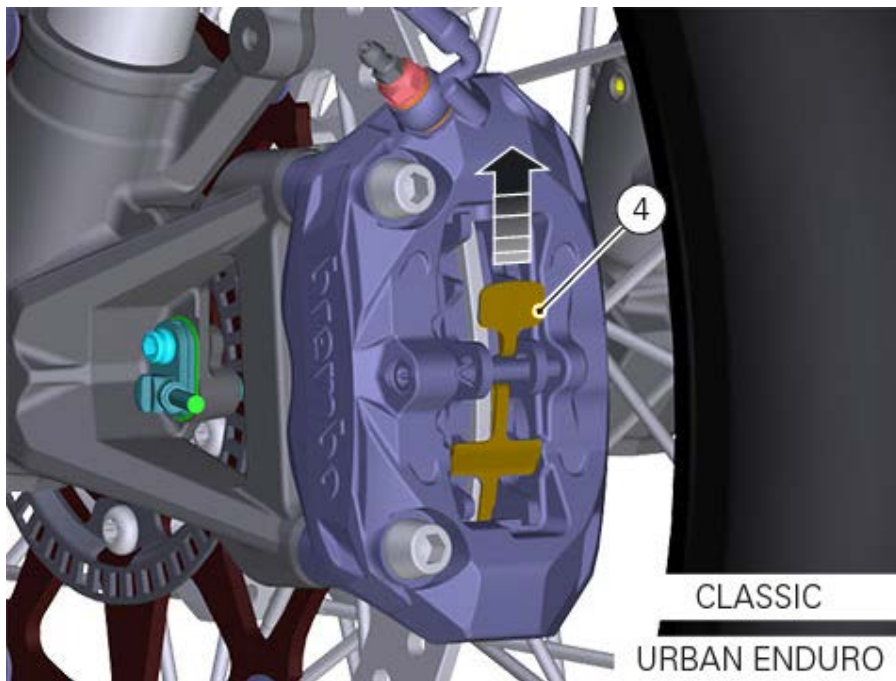

Operate the brake lever repeatedly so that the pads firmly bed in against the disc thanks to the brake fluid pressure.

Check that the level in the master cylinder tank is not below the MIN mark.

If necessary, top up as follows.

Turn the handlebars so that the reservoir is levelled.

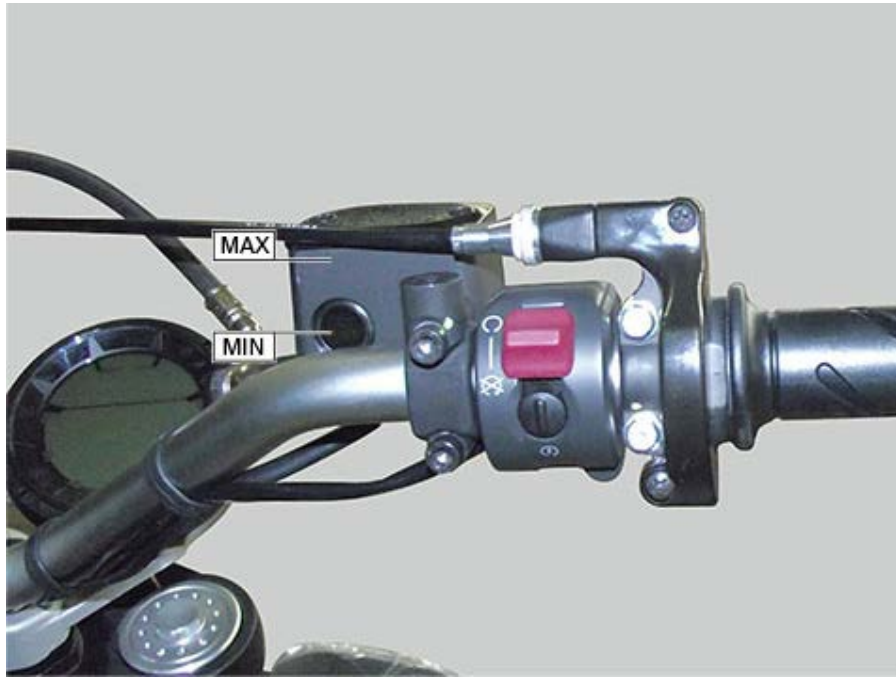

Remove the reservoir cover (5) by loosening the two screws (6).
Remove reservoir inner membrane.
Top up with recommended fluid up to maximum level.
Refit the removed components.

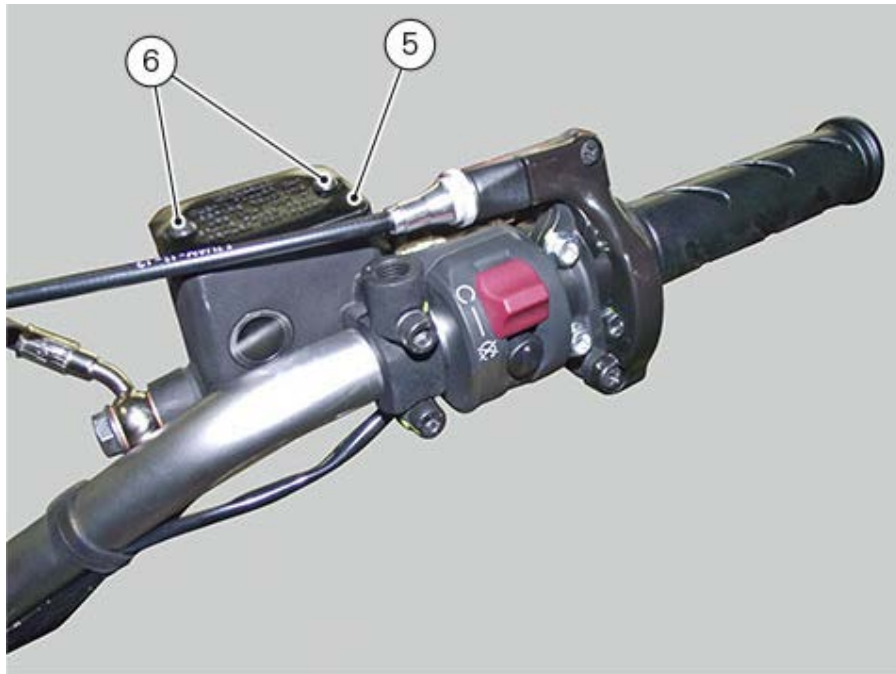

Adjusting the chain tension

Slowly move the motorcycle until you find the position where chain is tightest.

Set the motorcycle on the side stand.

Measure chain tension at the centre of the lower section, with the motorcycle on the side stand: lower the chain by pressing down on it only with your finger, release it and measure the distance between the centre of the chain pins and the aluminium section of the swingarm.

Value (A) must be: $27 \div 29$ mm

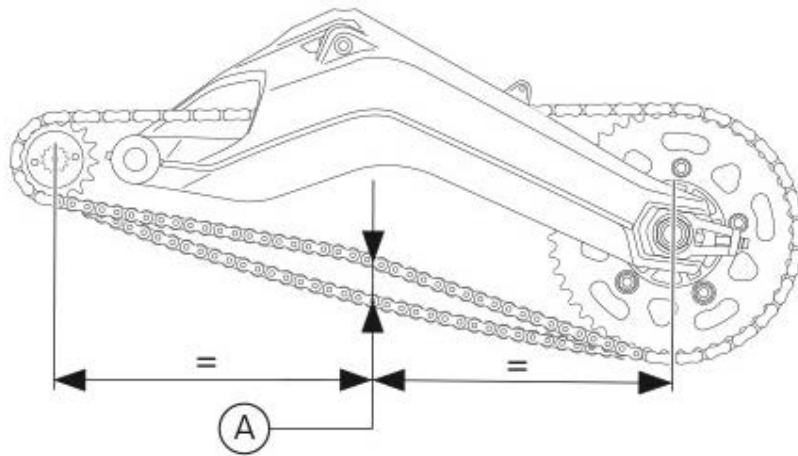

If the chain tensioning has to be changed, proceed as follows:

Loosen rear wheel retaining nut (1).





Work on screw (3), on both vehicle sides, to change the chain tensioning.
Once adjustment is completed, visually make sure that the number of reference notches (5) is the same on both left and right chain sliders, taking edge (4) as a reference.

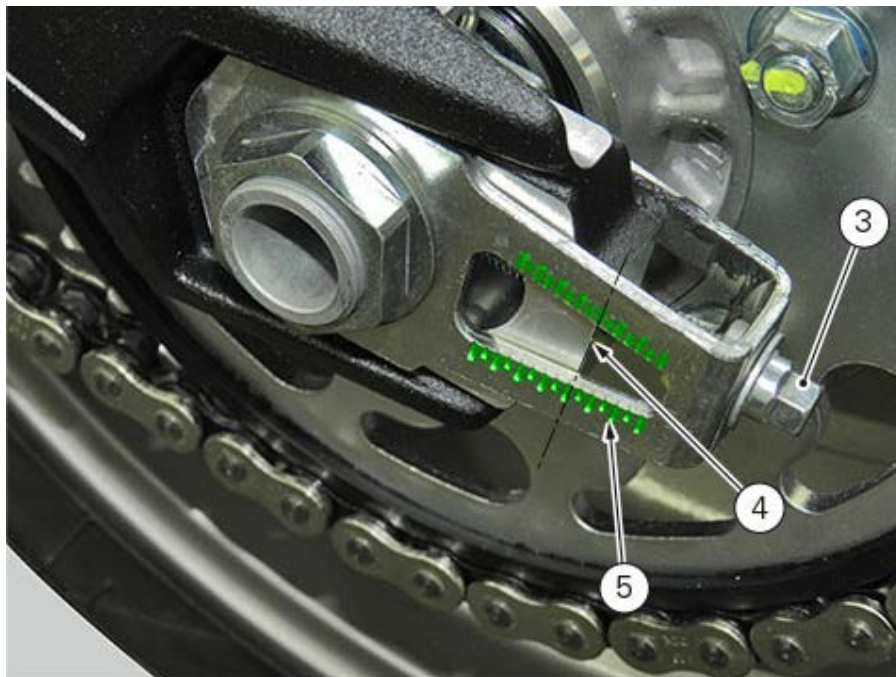

Once the adjustment is completed, tighten nut (1) to a torque of $145 \text{ Nm} \pm 5\%$.



Adjusting the steering head bearing play

Excessive handlebar play or shaking fork in the steering head indicate that the play of the steering head bearings requires adjustment as follows.

Undo the four screws (1), remove U-bolt (2) and handlebar (3) from steering head, setting it so as not to hinder the following operations.

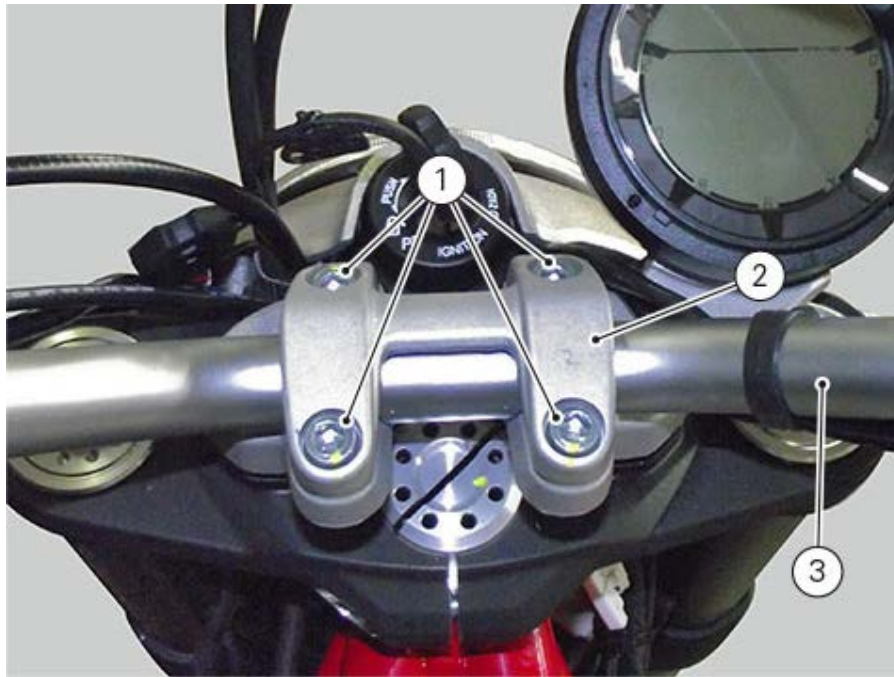

Slacken the clamp screws (4) securing the steering head to both fork legs.



Loosen the clamp screw (5) that holds the steering tube to the steering head. Turn with tool no. **88713.1058** the ring nut (6) to a torque of 30 Nm \pm 5%.

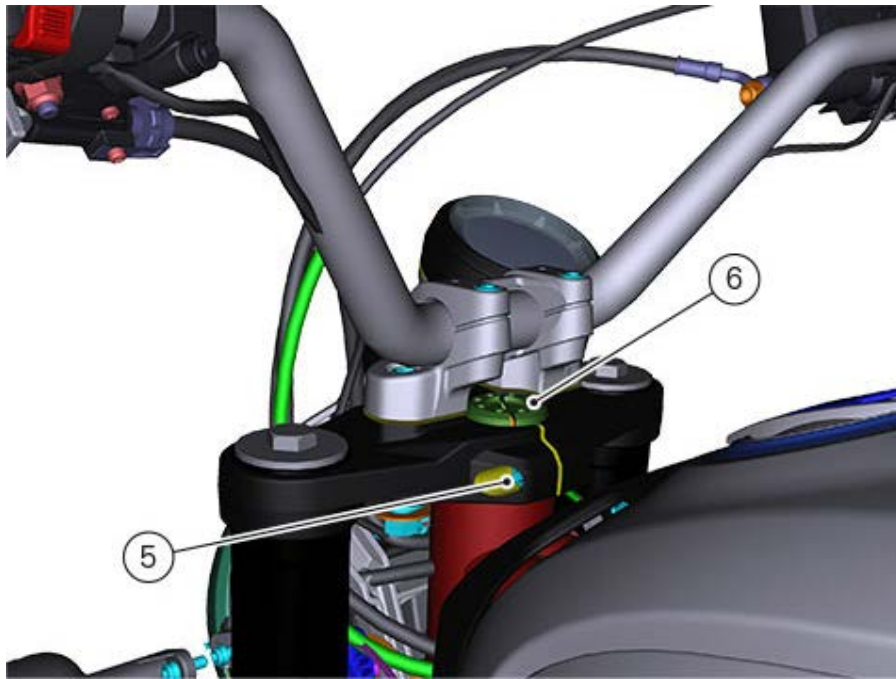

Tighten screws (4) and (5) previously loosened to a torque of $24 \text{ Nm} \pm 5\%$.

Reposition handlebar (3), install U-bolt (2), smear screws (1) with specified grease and tighten the four screws (1) to $25 \text{ Nm} \pm 5\%$, following a 1-2-3-4-3 sequence.

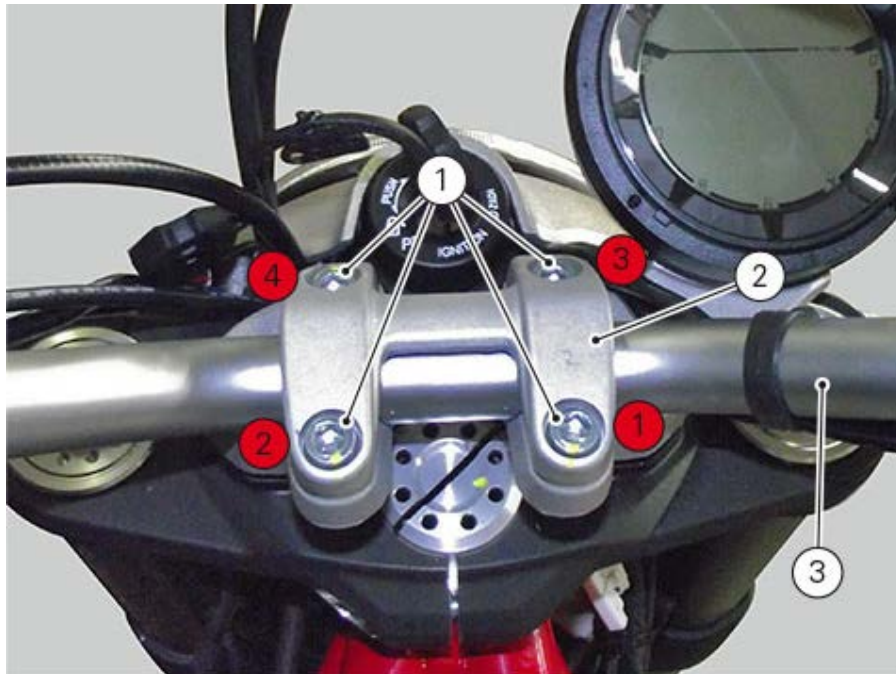

Clutch control cable adjustment

Warning

A wrong adjustment can seriously affect the clutch operation and duration.

A worn clutch tensions the clutch cable. Always check the free play, with cold engine, before using the vehicle.

Warning

Lever free play adjustment must be carried out with cold engine and with the motorcycle on its side stand and the handlebar fully turned to the right.

When operating the clutch lever (1), you must clearly feel the passage from a very low resistance to a very high resistance (operating force).

The free play corresponds to the lever travel where the clutch resistance force is very low.

Determine ring nut (2) and adjuster (3) position; ring nut (2) must be at a distance (A) of at least 5 mm from the lever rotation plate (4) and must not touch edge (5) of stop plate (6).

Operate the lever through its free play and check that distance "B" is between 2 mm and 3 mm.

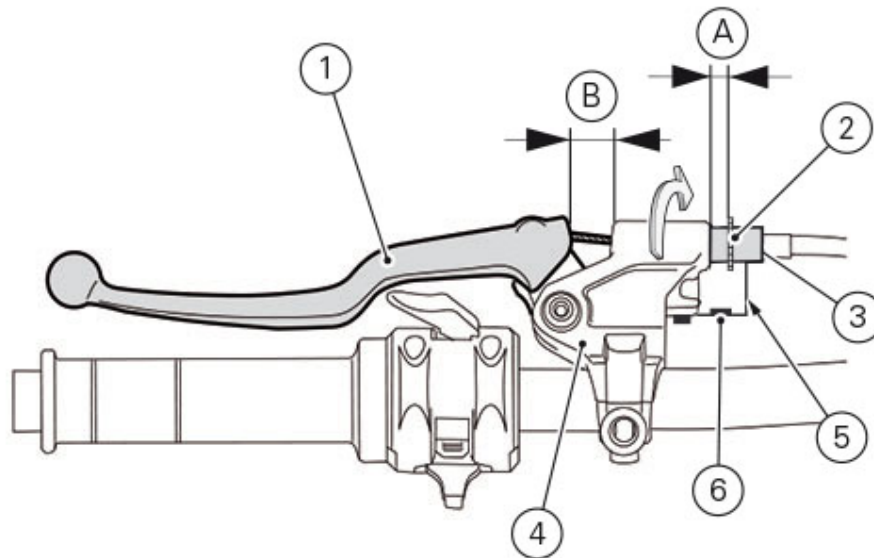

Adjuster (3), located on the lever, allows a maximum adjustment (C) of 11 mm, whereas the standard adjustment (starting one) is of 5 mm.

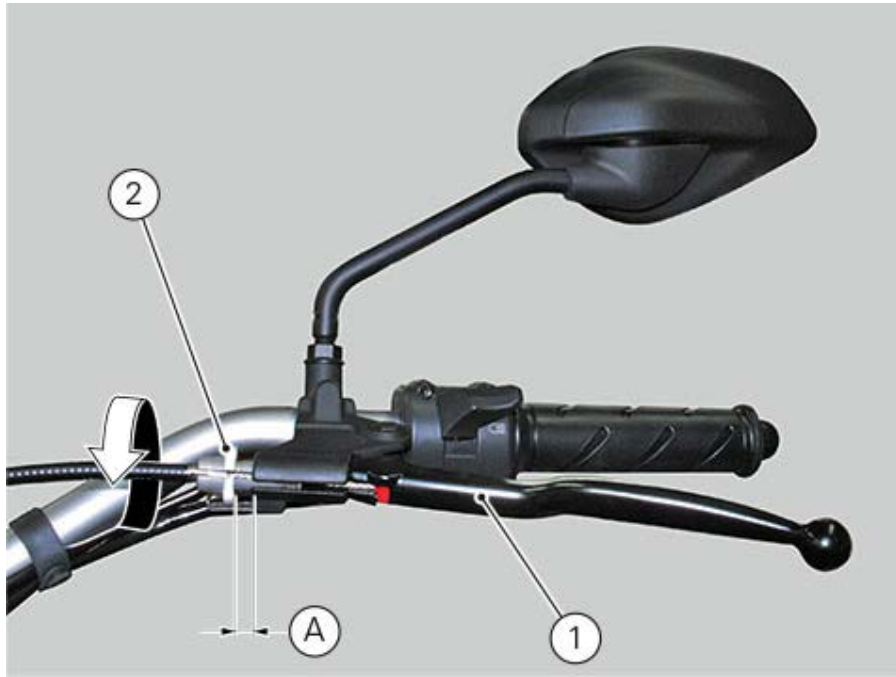

If the described conditions are not met, restore them as follows:
 Remove protection caps (7) and (8) and loosen adjuster (10) lock nut (9).

- To increase distance (A), increase the free play by tightening adjuster (10) and then working adjuster (3).
- To decrease distance (A), decrease the free play by loosening adjuster (10) and then working adjuster (3).

Tighten lock nut (9) to the specified torque while holding adjuster (10) and bring protective caps (7) and (8) back in place.
 Repeat all the tests.

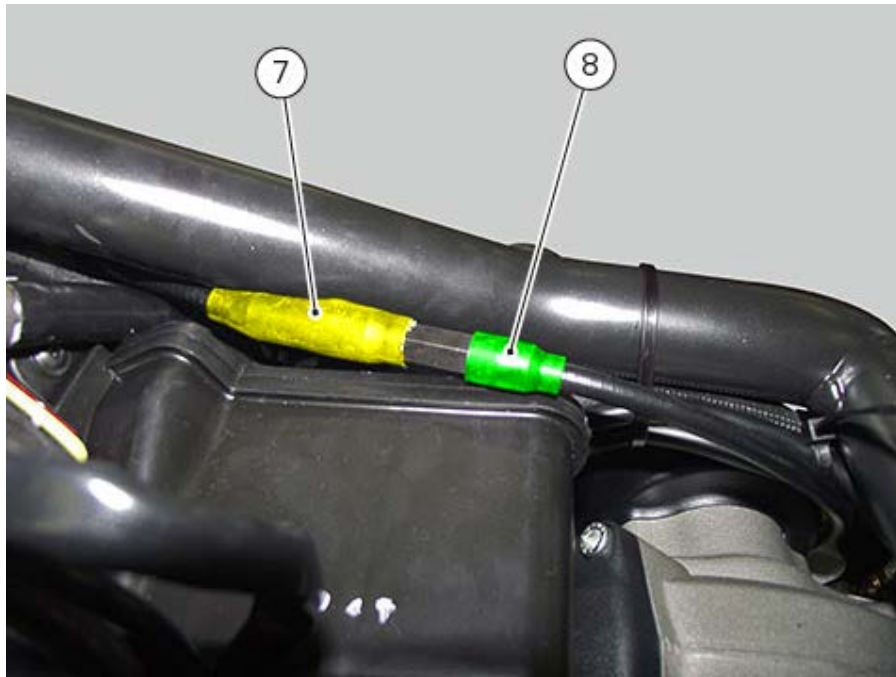

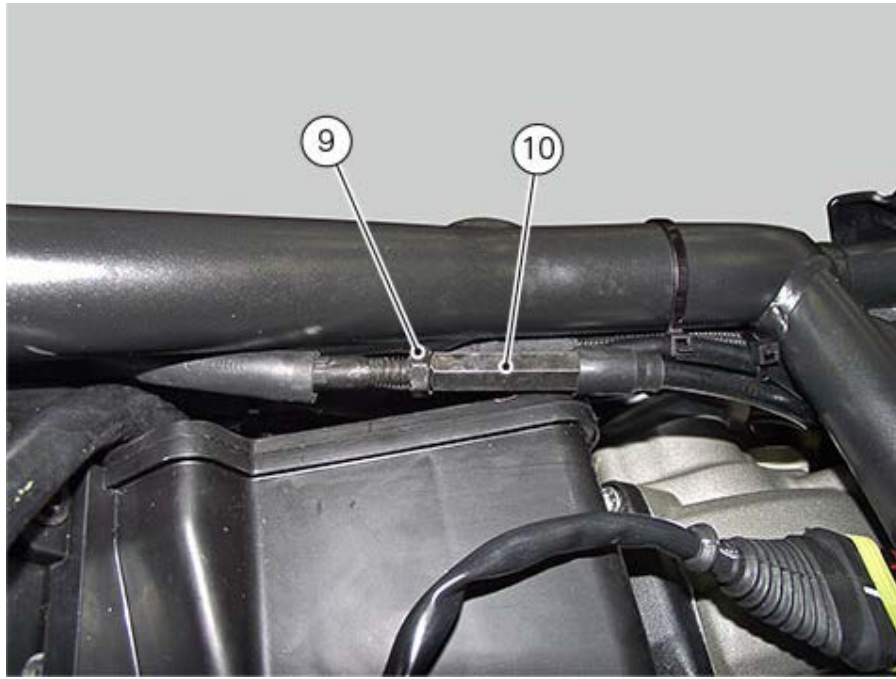

Changing the fluid in the rear brake circuit

Changing the fluid in the rear brake circuit Unscrew the cover (6) of the rear brake fluid reservoir (7).

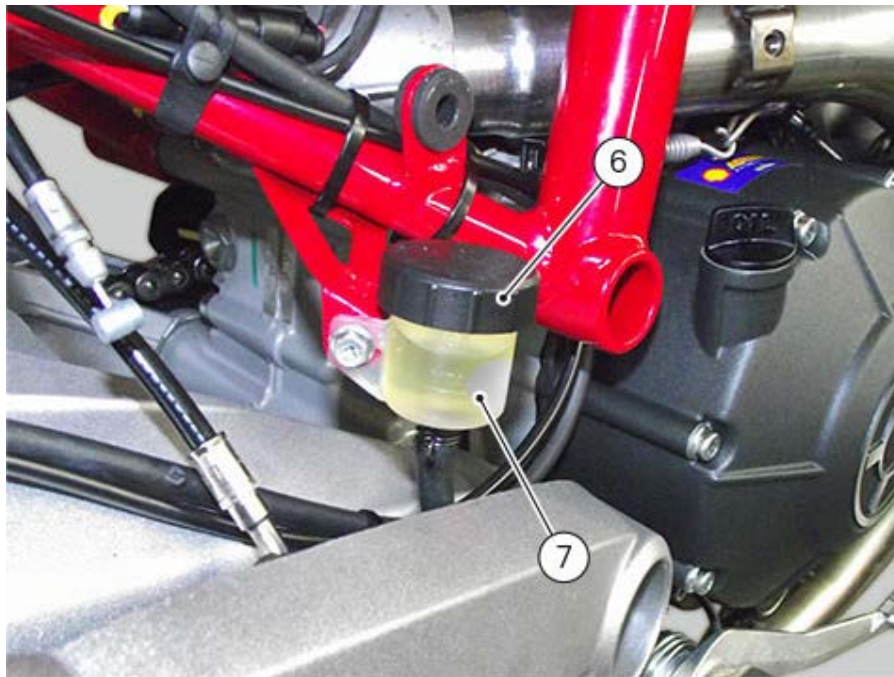

Attach a transparent plastic tubing to the bleed valve (8) and insert the other end of the tubing in a container placed on the floor.



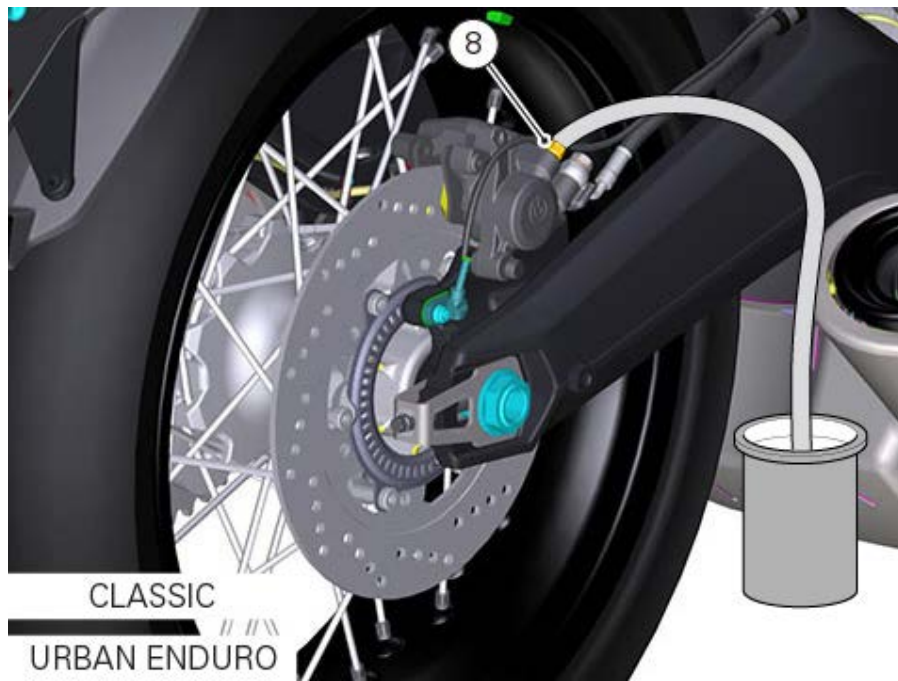

Siphon the fluid from the reservoir (6). Fill the reservoir (7) with new oil up to the MAX mark.



Attention

During the filling operation, always keep the fluid level above the MIN mark to avoid any air bubbles in the circuit.

Allow the fluid to flow from the bleeder (8) until it changes colour. Press the pedal two or three times until the circuit is pressurised. Hold pedal depressed.

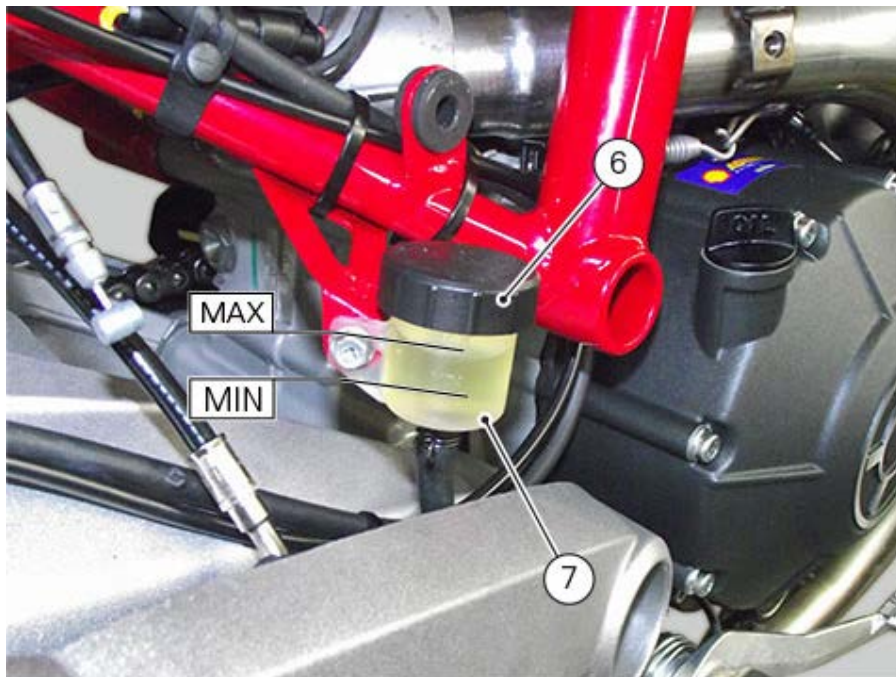

Open the bleed valve (8) to allow fluid to flow out.

The pedal is at the end of travel when it is in the lower position. Now, screw bleed valve (8) to a torque of $10 \text{ Nm} \pm 10\%$, and release the pedal; press the pedal again.

Repeat the above operation until the old fluid flows out completely.



Warning

After draining the old fluid from the reservoir and while filling the system, always keep the fluid level above the MIN mark to avoid any air bubbles in the circuit.

Changing the fluid in the front brake circuit

Warning

Brake fluid is corrosive and will damage paint. Avoid contact with eyes and skin. In case of accidental contact, wash thoroughly with water.

Remove the cover with membrane (1) from the front brake fluid reservoir (2) by undoing the screws (3). Siphon the fluid from the reservoir (2) using suitable equipment. Refit the membrane (without the plug) on the reservoir to avoid brake fluid splashes during the following operations.

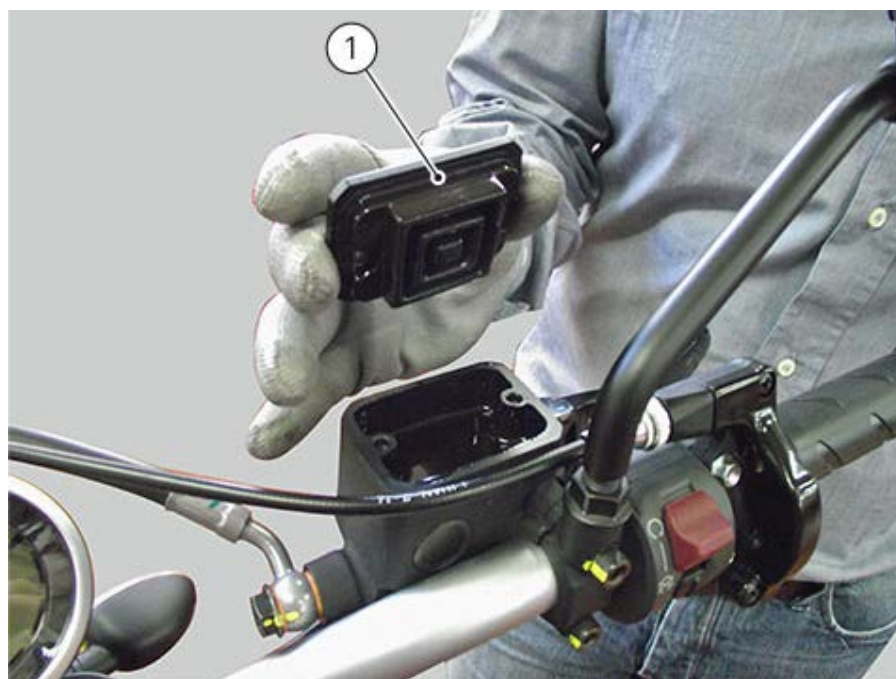
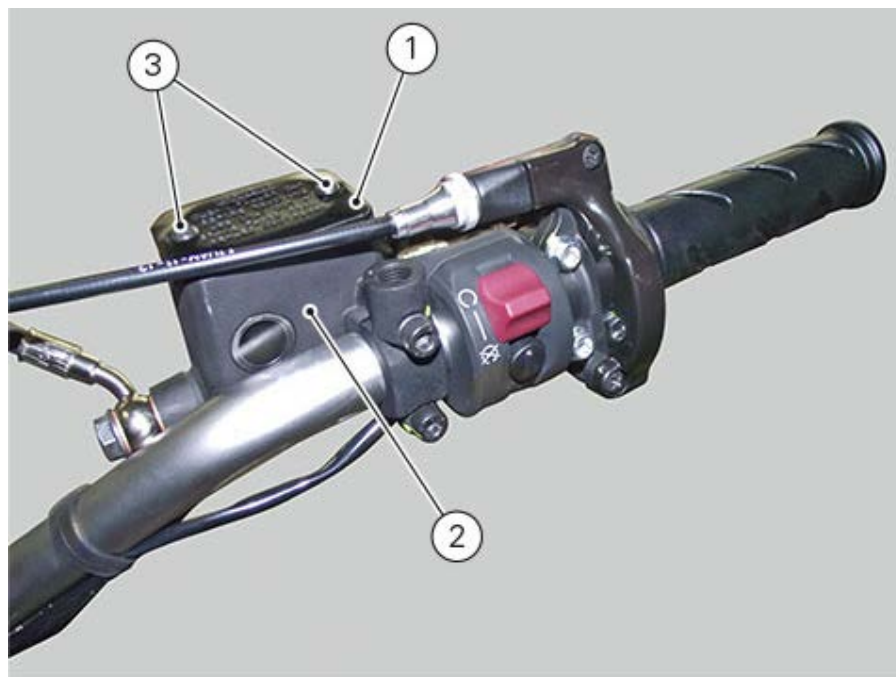



Move the brake calliper pistons back: to carry out this operation undo the fixing screws (4) of the calliper on the fork bottom end and push pads taking them apart; during this operation, be careful with the fluid level, which must always be sucked out each time it flows back in the reservoir.



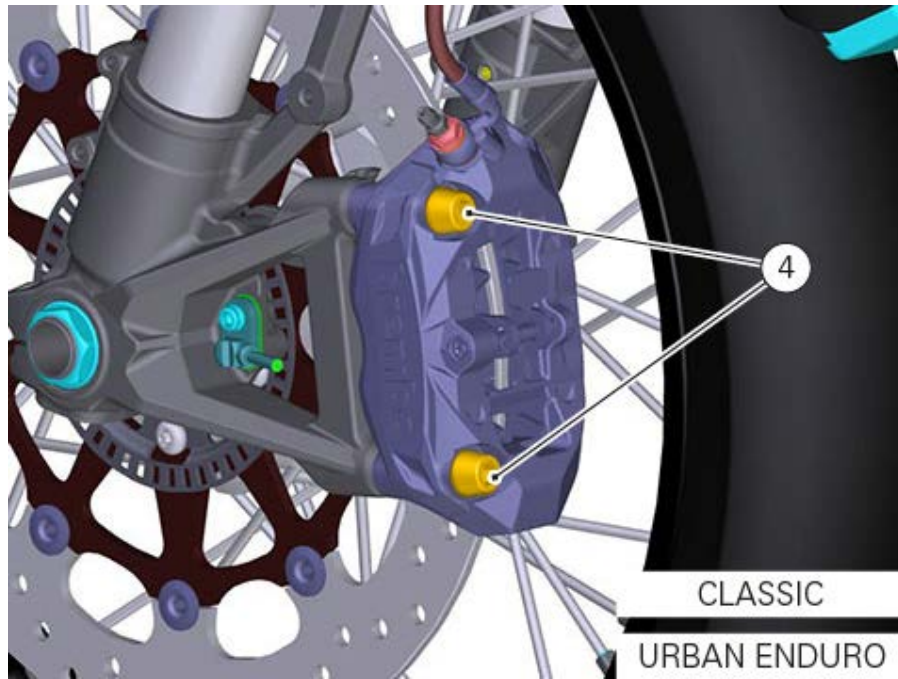

Once that all pistons are fully moved back and that all the fluid in the tank has been sucked out, connect to the bleed valve (5) a transparent tube by immersing the end in a container placed on the floor.



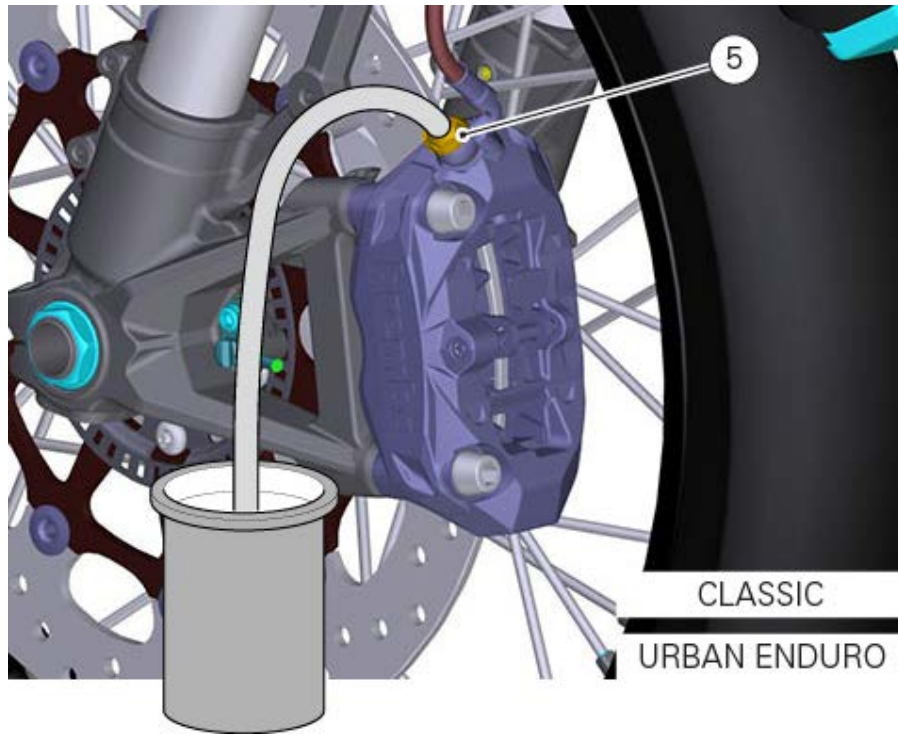

Fill the reservoir (2) with new oil up to the MAX mark.

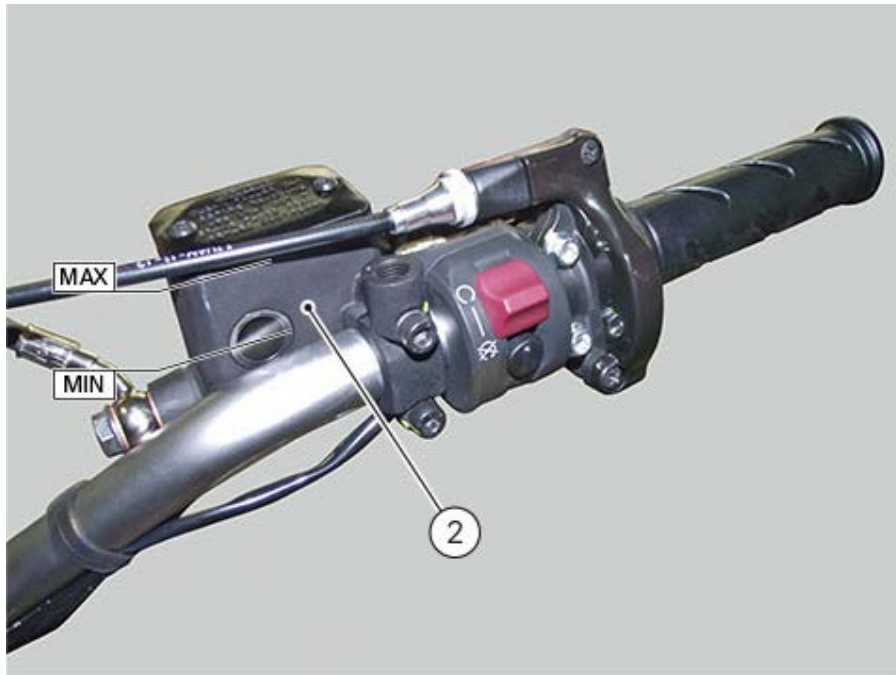

Pull the lever to make a 20 - 30 mm stroke and keep the lever in this position using a non-elastic clamp.



Loosen the bleed valve of the calliper (5) and then take the lever through the whole stroke to allow fluid to flow out.
The lever is resting against the handgrip.



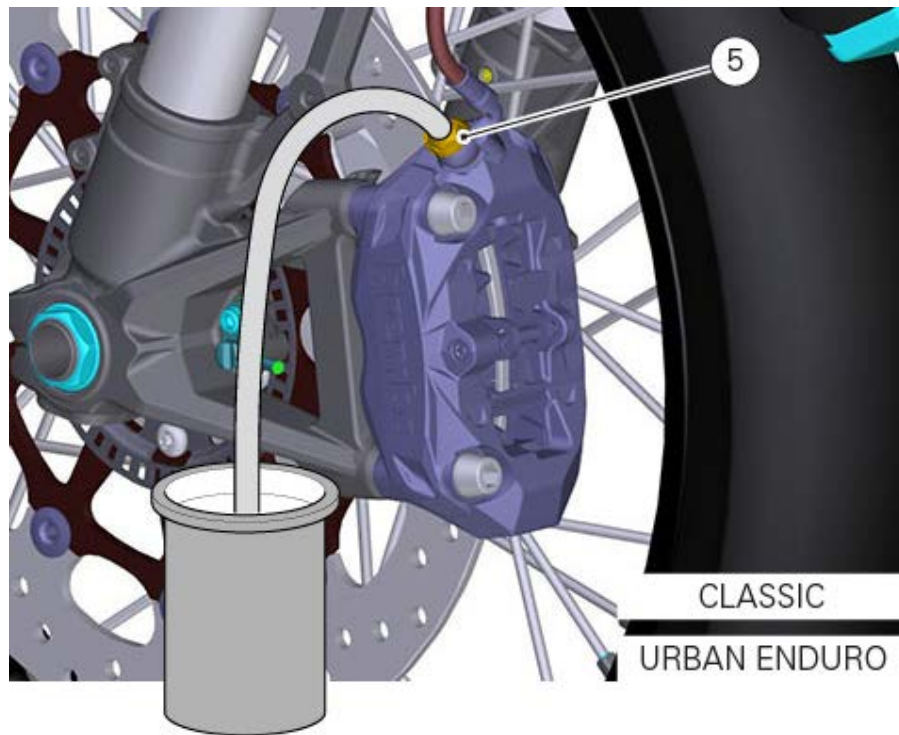

Tighten the bleed valve (5) to a torque of $4 \text{ Nm} \pm 10\%$ and then release the lever.
Repeat the above operation until the old fluid flows out completely. Then, with the bleed valve definitely closed to the specified torque actuate repeatedly the lever until a pressure is detected in the brake system.

⚠ Warning

After draining the old fluid from the reservoir and while filling the system, always keep the fluid level above the MIN mark to avoid any air bubbles in the circuit.

Changing and cleaning the air filters

Remove the side fairings and disconnect voltage regulator ([Removing the airbox](#)).

Loosen screws (1) on airbox cover (2).

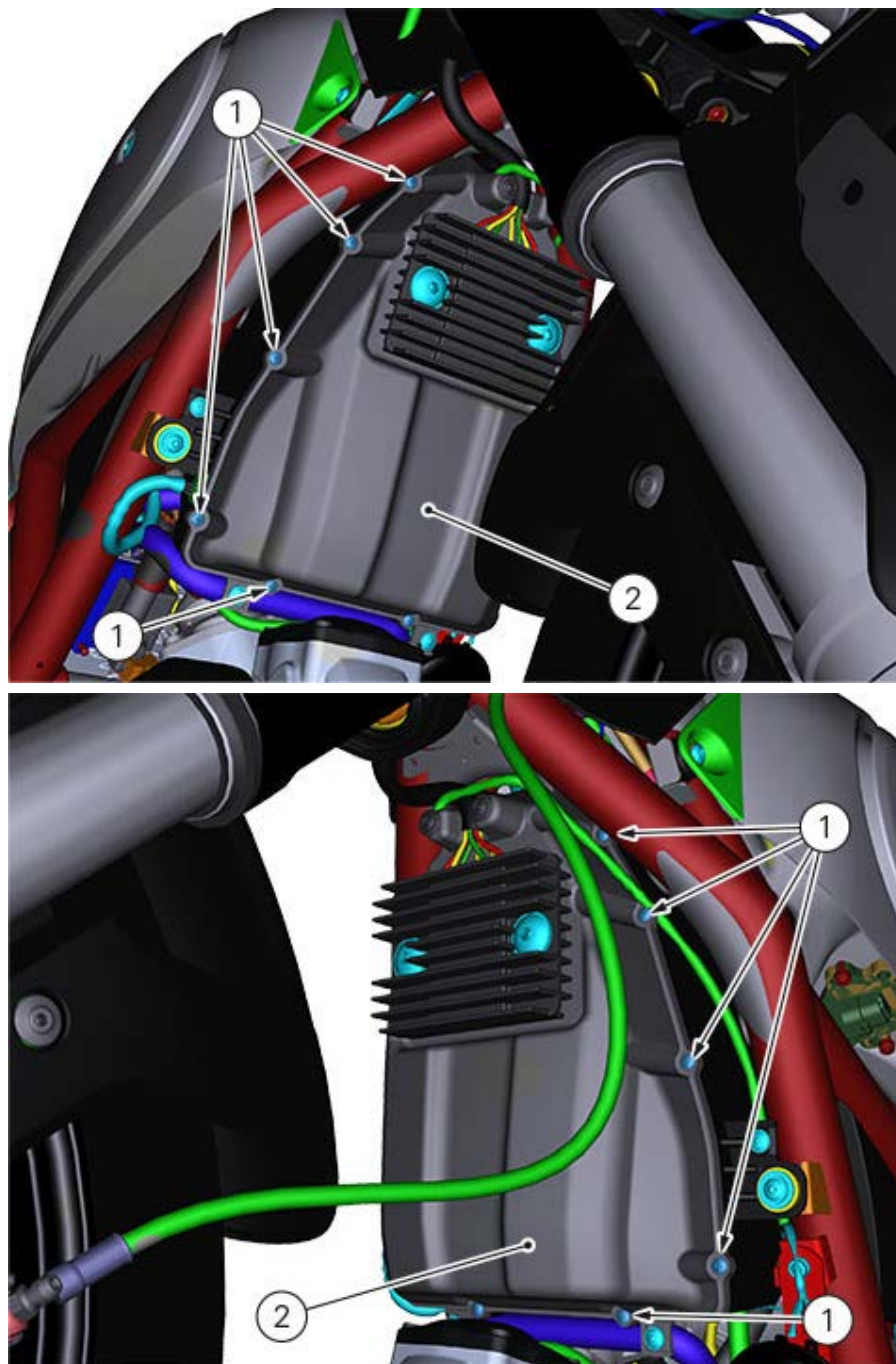

Remove the airbox cover (2).
Remove filter (4) from cover (3).



Blow cartridge clean using compressed air or change it.

Important

A clogged air filter will reduce air intake and engine power, increase fuel consumption and cause a build up of deposits on the spark plugs. Do not use the motorcycle without a filter as impurities in the air could get into the engine and cause damage.

Properly reinstall cartridge on airbox cover and refit all removed parts, in particular tighten screws (1) to 5 Nm \pm 10%.
Reconnect voltage regulator.

Important

If the motorcycle is used in very damp or dusty conditions, the air filter cartridge must be changed more frequently.

Replacing the spark plugs

Check the colour of the ceramic insulation around the central electrode: an even, light brown colour indicates the engine is in good condition and running at the right temperature. Check central electrode for wear.



Warning

Do not use spark plugs with inadequate heat rating or incorrect thread length. The spark plug must be securely installed. If a spark plug is loose, it can overheat and damage the engine.

Spark plug type
Make: NGK
Type: DCPR8E

Remove spark plug cap (1), loosen spark plug (2) and remove it. Change it with a new one having the suitable heat rating. Repeat this operation on the other head.



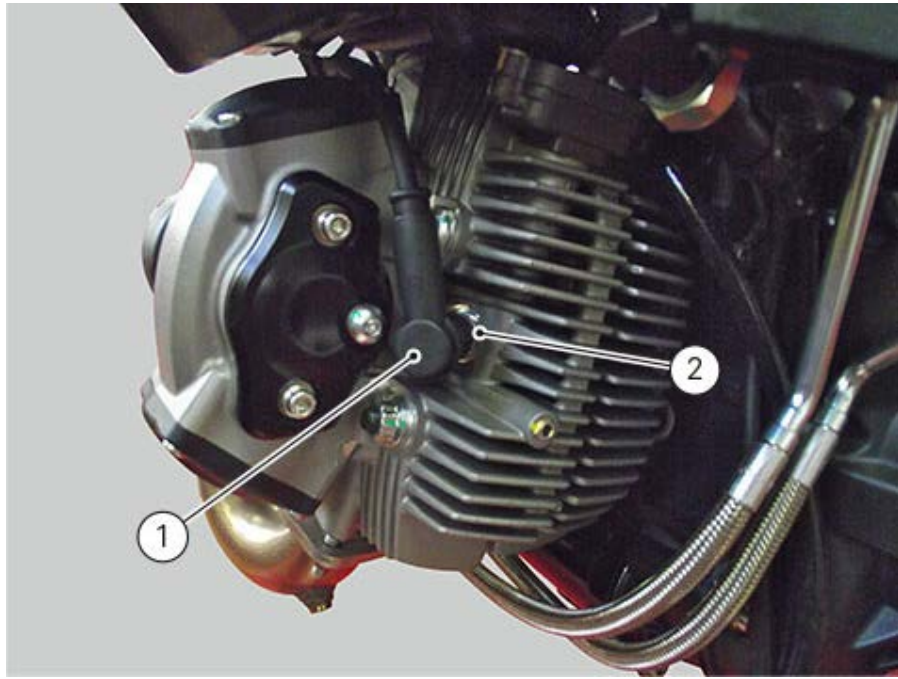

Changing the timing belts

Remove the exhaust system ([Removing the exhaust system](#)).

Remove the belt covers ([Removing the timing belt external covers](#)).

Working from vehicle left-hand side, loosen the two screws (3) and remove plug (1) from generator cover (2) .

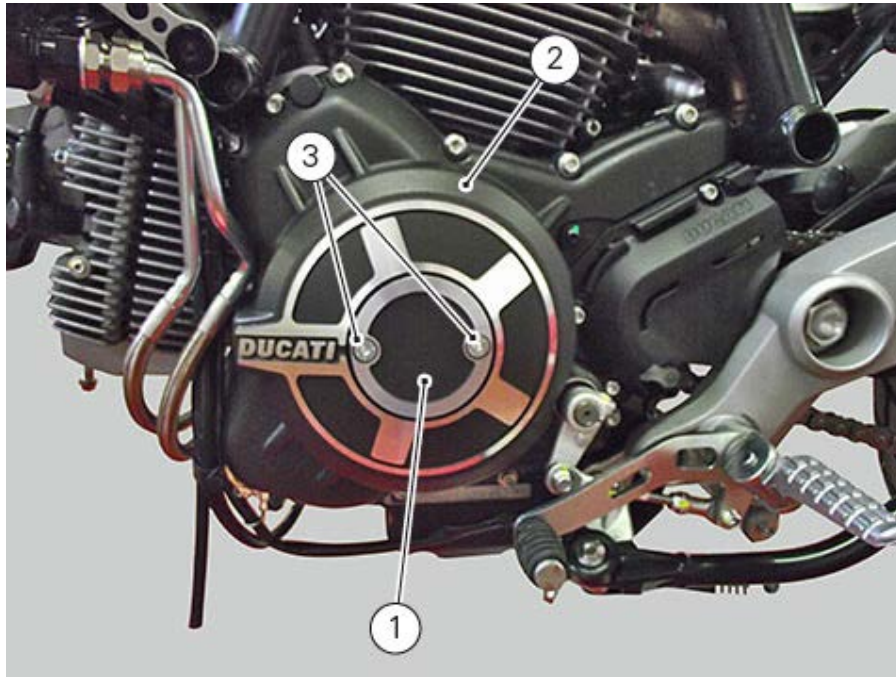

Fit tool (A) part no. **88713.2011** so that pins inside the tool engage into the two notches (4) on generator cover.



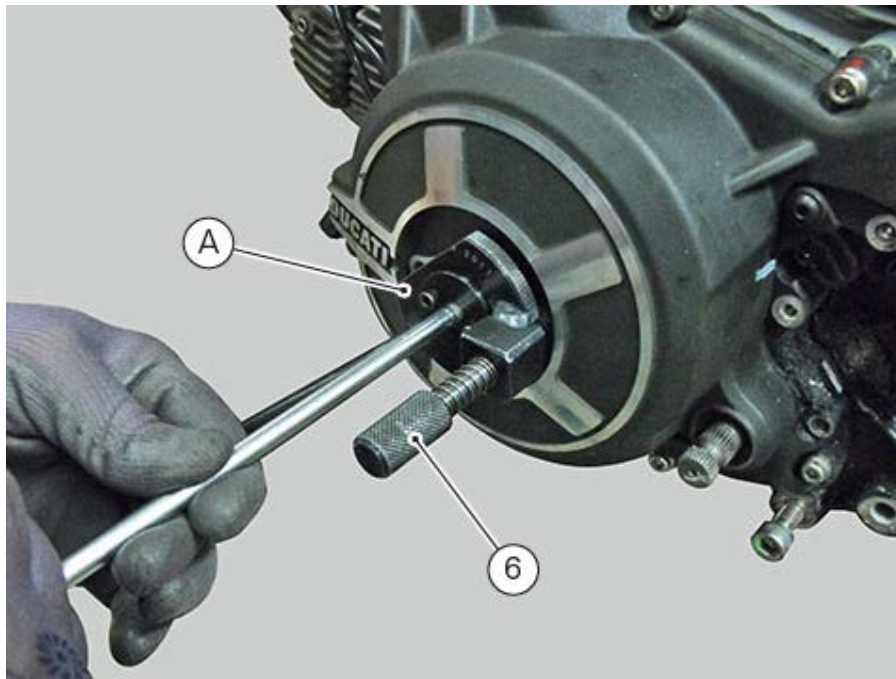

Working on the opposite side, align the reference mark on belt roller (7) with the reference mark on crankcase (8).

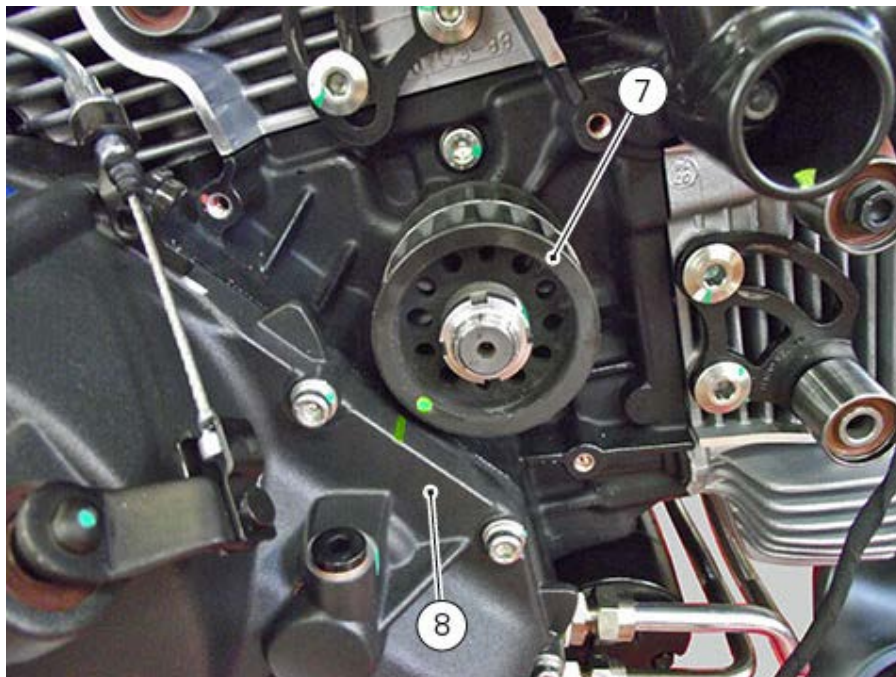

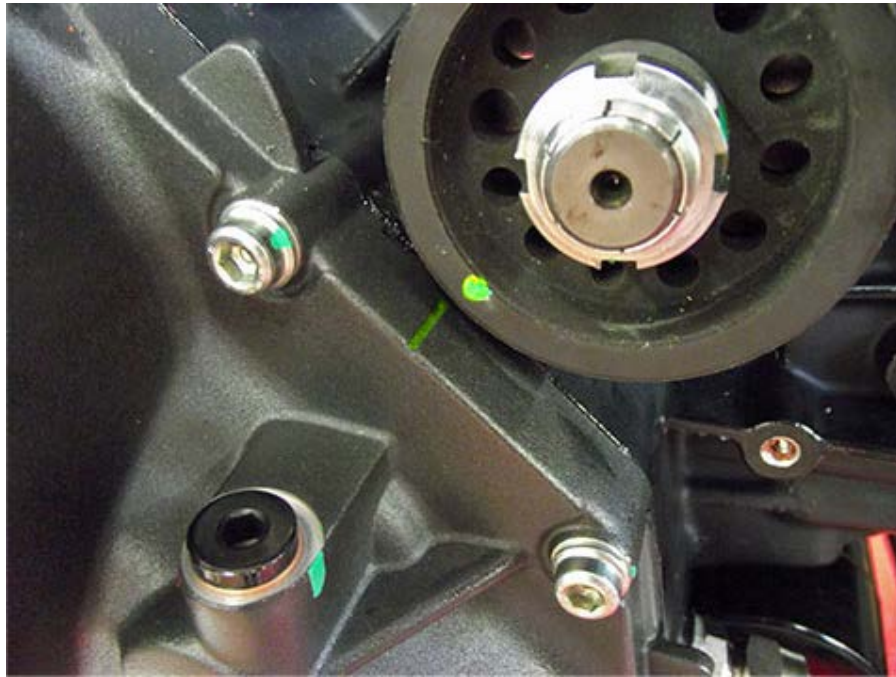

This condition is the TDC in the combustion stage with the horizontal cylinder. Check it by inserting tool (B) in the spark plug hole.

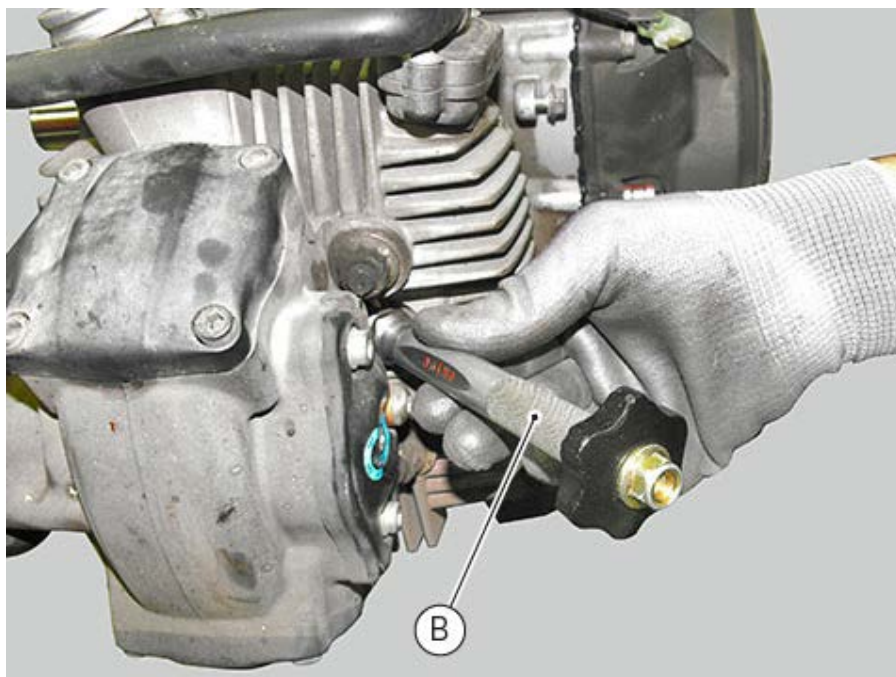

Now tool (A) pin (6) should be aligned with one of the two holes (5) on generator casing. Tighten pin (6) so as to lock out tool (A) rotation.

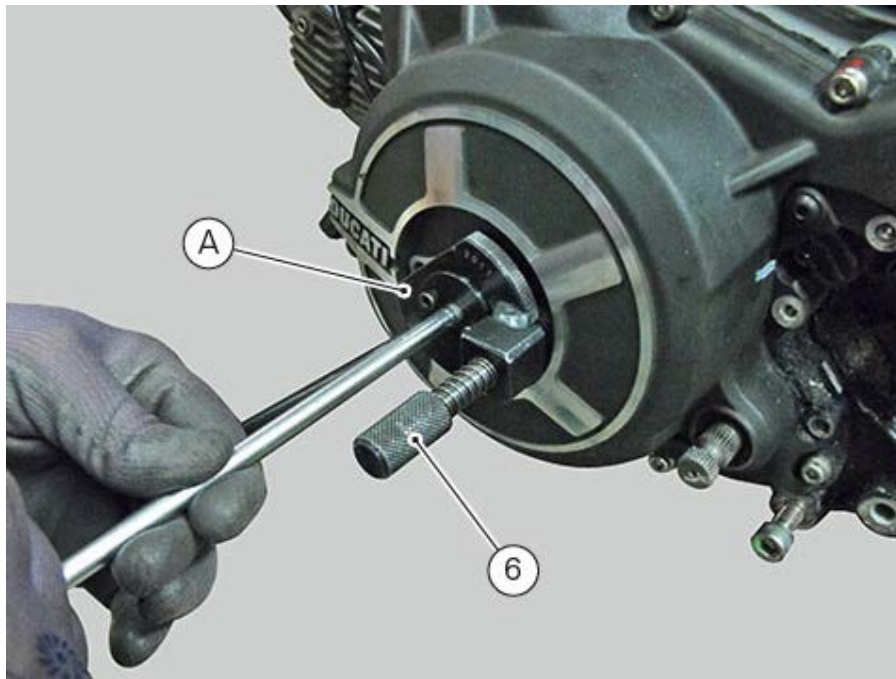

Work on the vertical head and remove spark plug cap and plug (9).
Fit tool (C) part no. **88713.2288** fully home.
If that is not possible, turn belt roller (7) until tool (C) can be inserted fully home.



Loosen screws (11) of pulley (12) - vertical and horizontal cylinder.
Turn pulley counter clockwise.

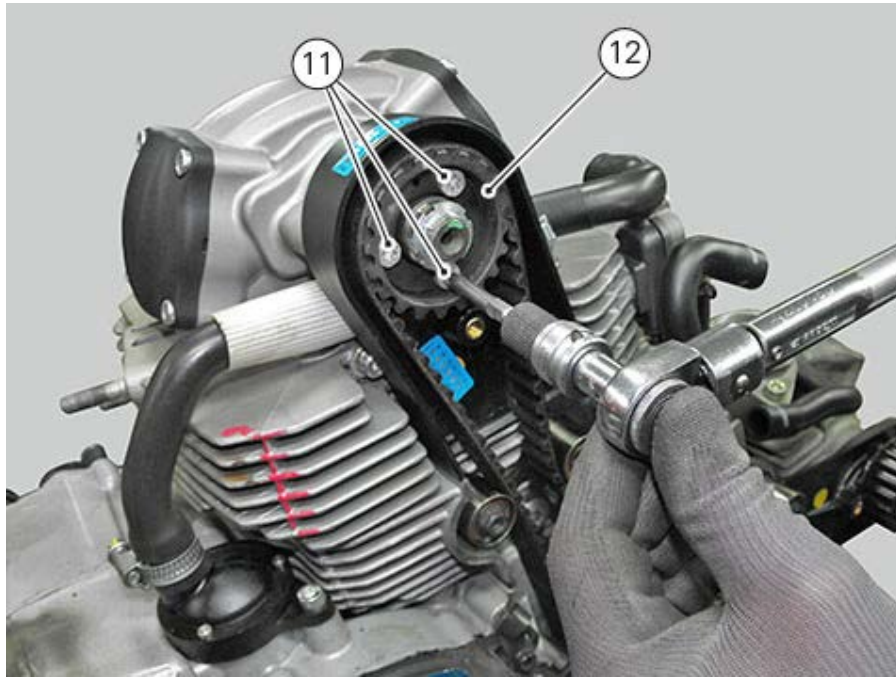

Loosen the two screws (13) from belt tensioner (14) on vertical cylinder and belt tensioner (15) on horizontal cylinder.

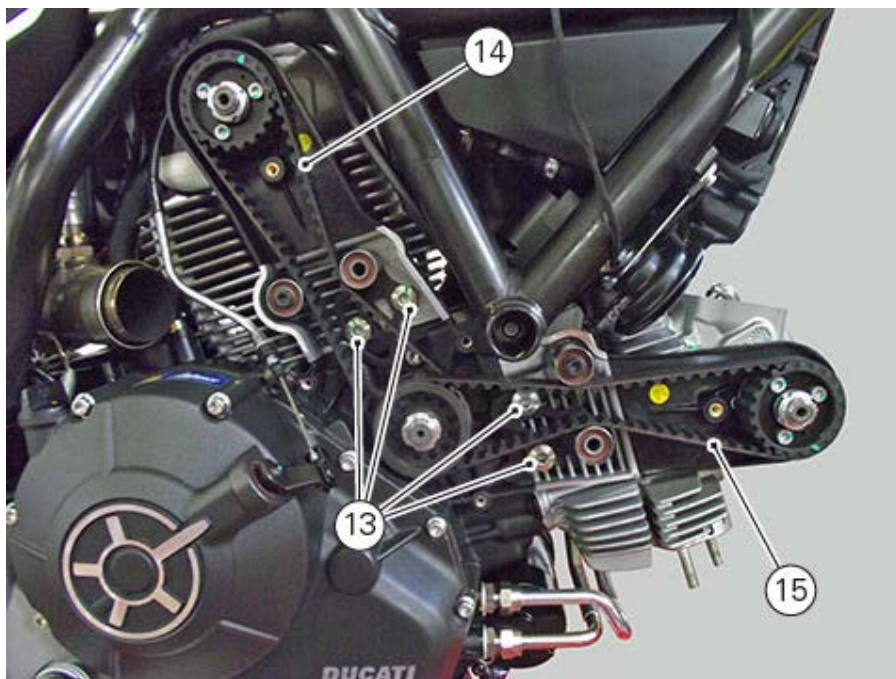

Remove both belts.

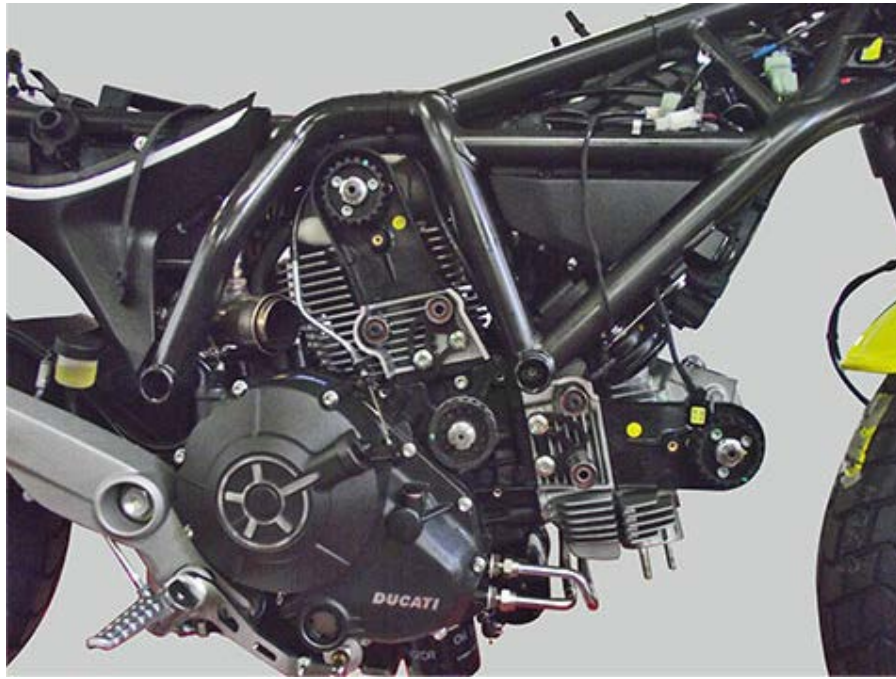

Fit belt (14) and tension it by hand using the mobile belt tensioner (16).

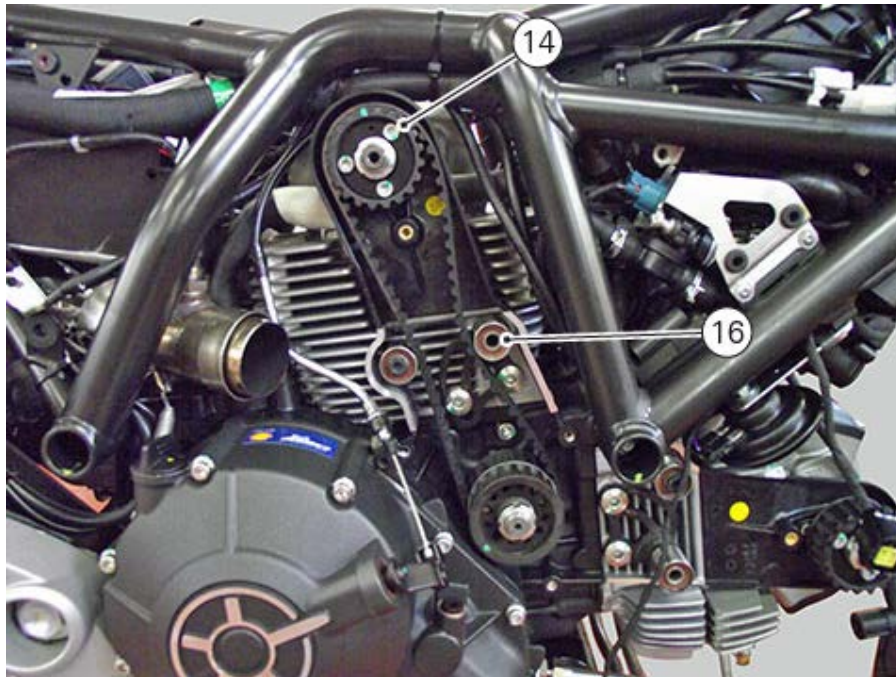

Check proper tensioning using the suitable tool (D) part no. **97900.0253**, frequency reading for proper tensioning is **140** Hz with a new belt.
If this value is not reached, work the mobile tensioner (16) until getting the proper reading.



Tighten screws (11) of pulley (12).

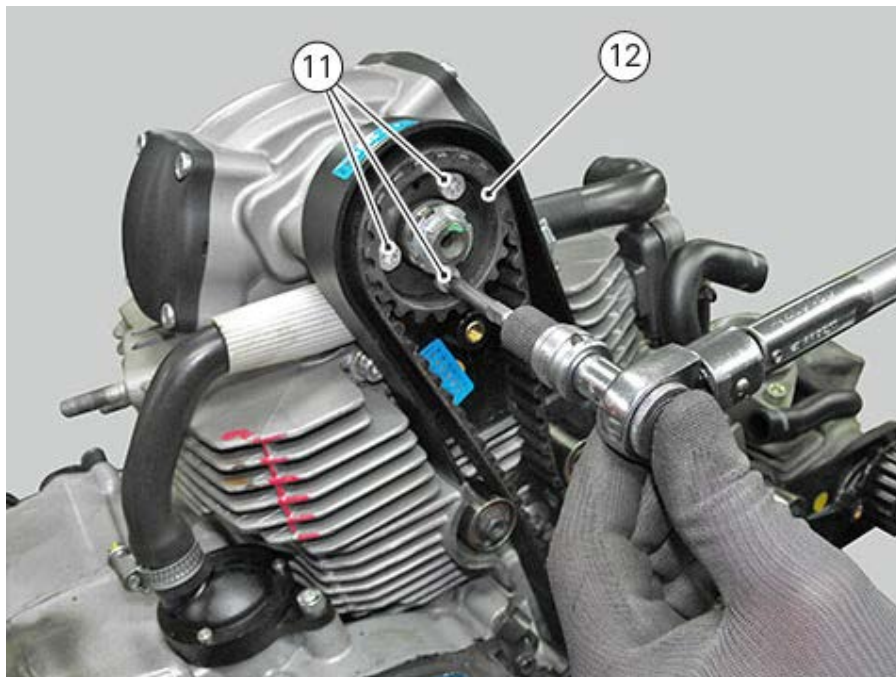

Remove tool (C), tighten the plug and put back spark plug cap.
Apply the same procedure to the horizontal head.

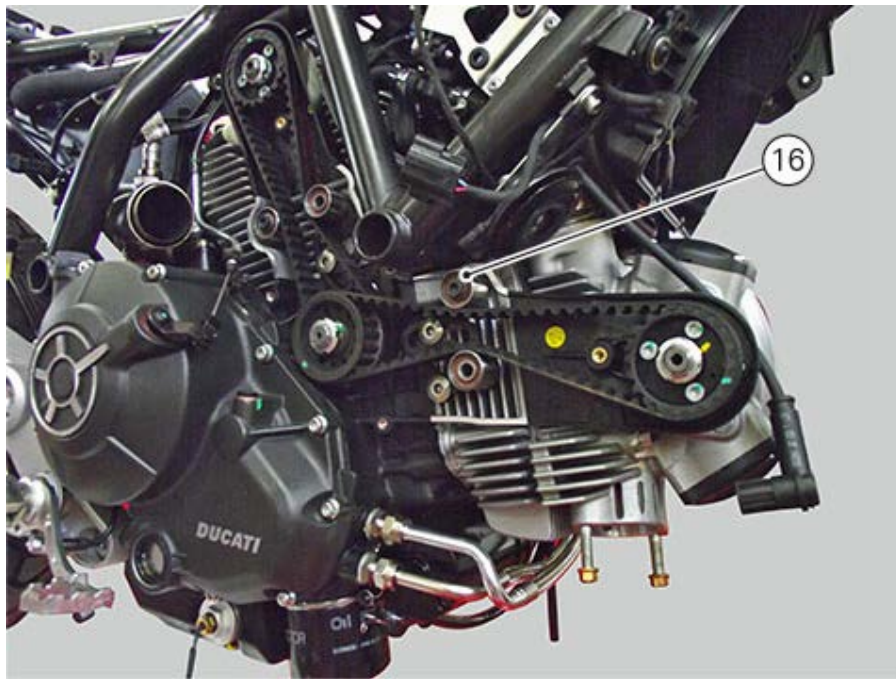
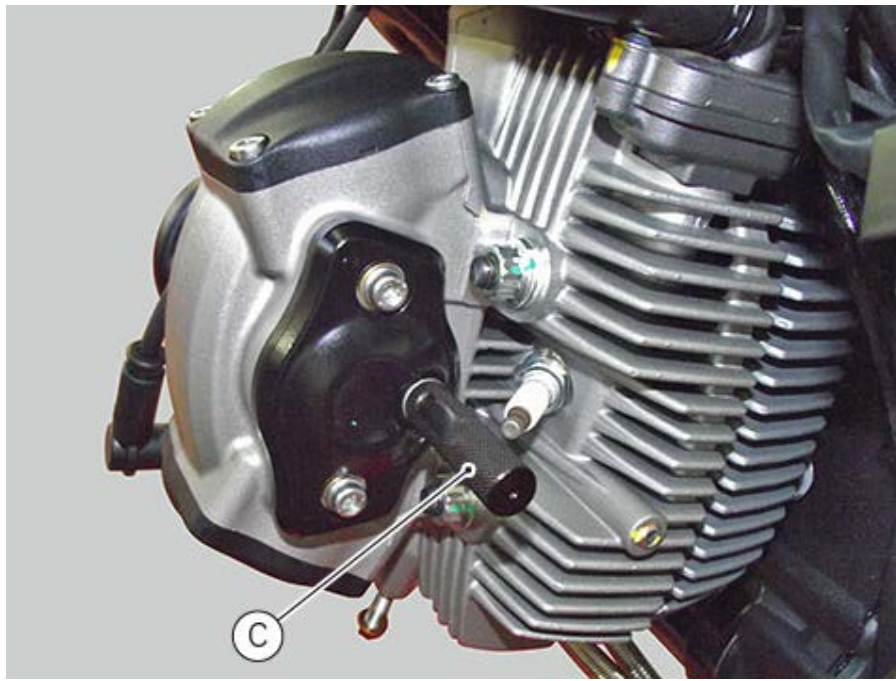



Refit the belt covers (Refitting the timing belt external covers).
Refit the exhaust system (Refitting the exhaust system).

Checking valve clearance

Remove the seat ([Removing the seat](#)).

Remove the fuel tank ([Removing the fuel tank](#)).

Remove the blow-by ([Removing the airbox](#)).

Remove the following parts from the electrical component box:

- Battery;
- Starter relay;
- Fuse box;

Remove the cylinder head covers (1).

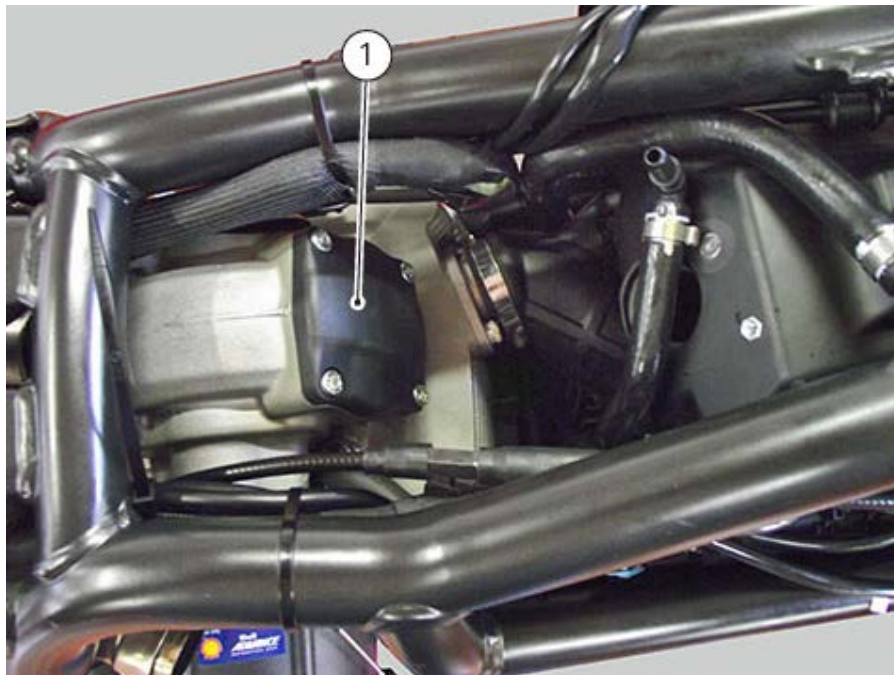
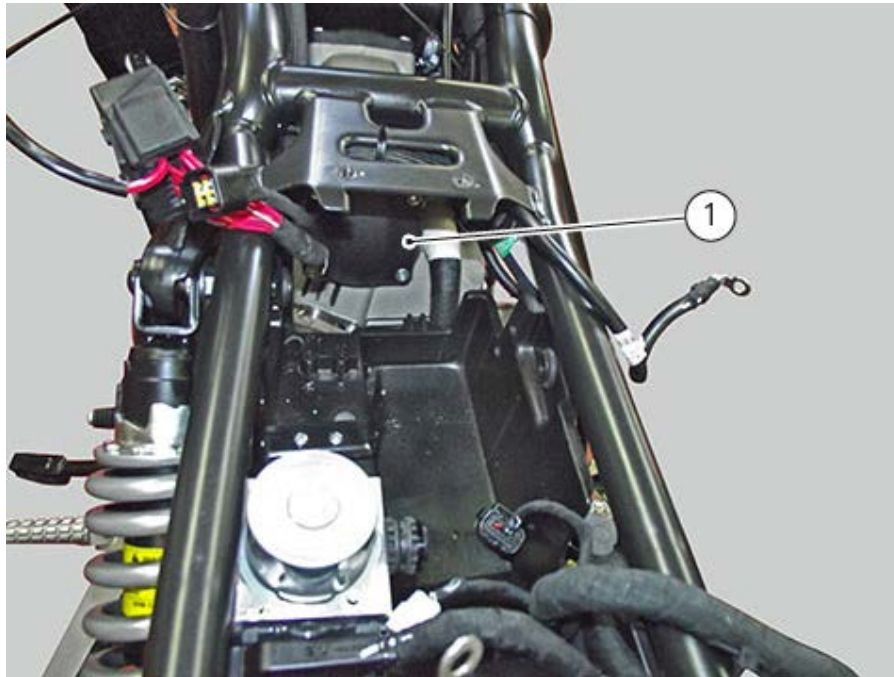

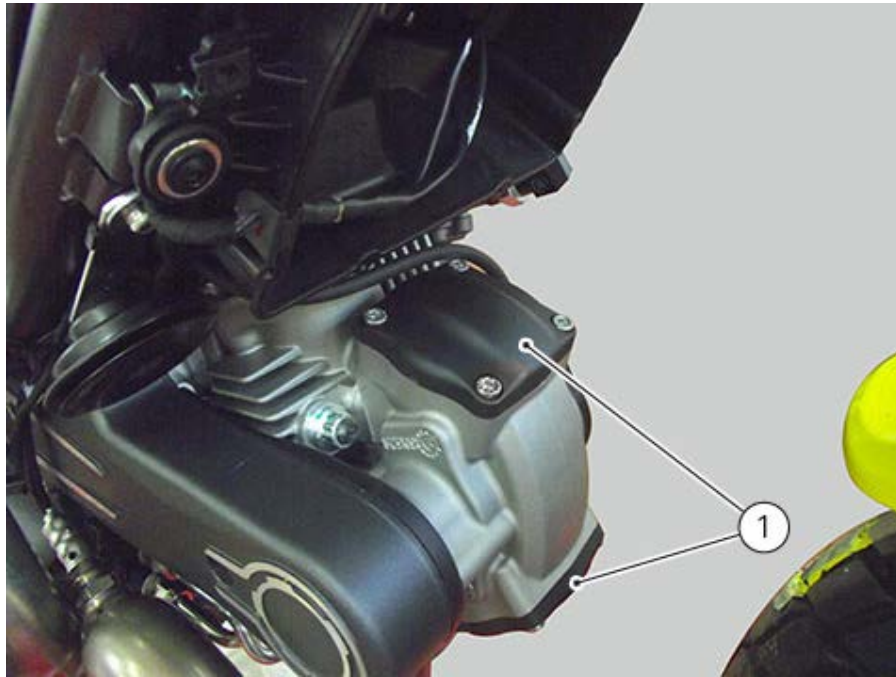

Fit tool part no. **88713.011** and ensure the two tool pins match the two slots on crankcase following the same procedure as for "[Changing the belts](#)". Turn the crankshaft so that the valve to be inspected is in rest position.

With the valve in the rest position, slide a feeler gauge between opening rocker arm and shim to measure the clearance. The clearance must be within the specified limits:

Opening rocker arm	
INTAKE	
Assembly	0.10÷0.15 mm
Inspection	0.10÷0.15 mm
EXHAUST	
Assembly	0.10÷0.15 mm
Inspection	0.10÷0.15 mm

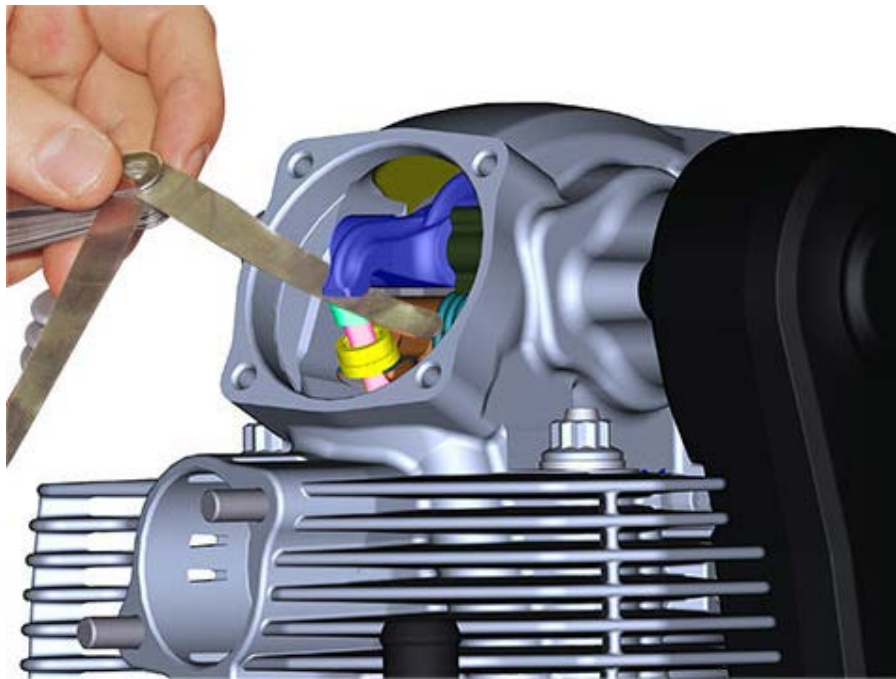

With the valve in the rest position, slide a feeler gauge between closing rocker arm and shim to measure the clearance.

Closing rocker arm	
INTAKE	
Assembly	0÷0.05 mm
Inspection	0÷0.05 mm
EXHAUST	
Assembly	0÷0.05 mm
Inspection	0÷0.05 mm

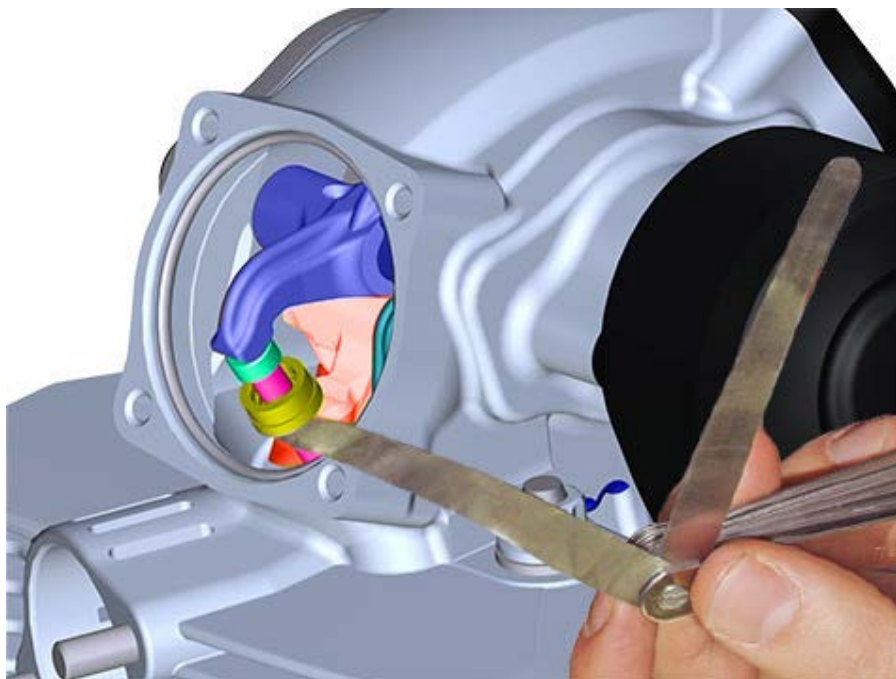

If detected values exceed the specified limits, replace opening and/or closing shims, as described in

paragraph "[Removing the valves and rocker arms](#)", with one featuring an adequate thickness to obtain the specified clearance.



Note

Opening rocker arm shims measuring from 1.8 to 3.45 and closing rocker arm shims from 2.2 to 4.5 are available as spare parts: the size is punched on the shim.

Reassemble the removed components in the removal reverse order.

Changing the engine oil and filter cartridge

Engine oil



Note

This operation has to be carried out with hot engine (but turned off) because the oil in these conditions is more fluid and comes out faster and completely.

Remove the drain plug (1) with gasket (2) from the oil sump and allow the oil to drain off.



Warning

Dispose of oil and/or filter cartridges in compliance with environmental protection regulations.

Remove any metal deposits from the end of the magnetic drain plug (1) and refit the drain plug complete with gasket (2) to the sump.

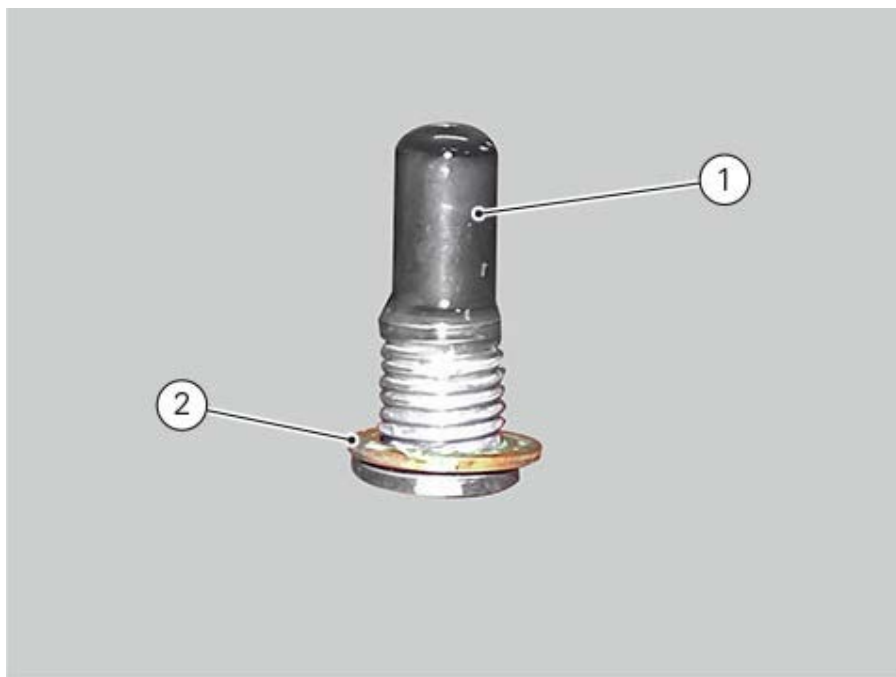
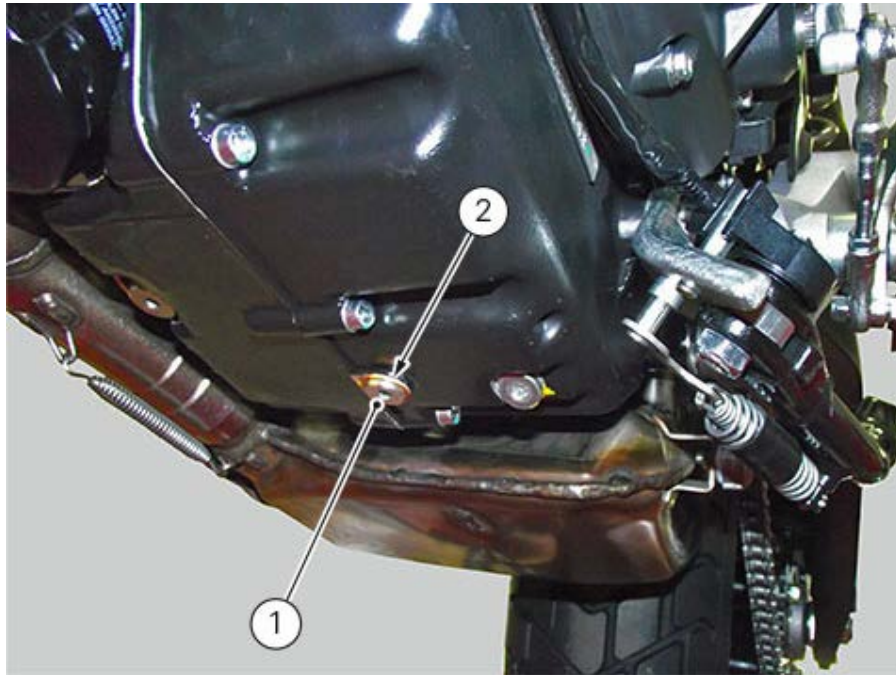

Tighten plug (1) to a torque of 42 Nm (Min. 38 Nm - Max. 46 Nm).

Filter cartridge

Remove the oil sump filter cartridge (3) using service tool part no. **88713.2906**.

Important

Dispose of the used filter, do not re-use it.

Fit a new cartridge (3), using tool part no. **88713.2906**.
Use engine oil to lubricate seal.

Note

As an alternative, it is advisable to refill the filter cartridge with engine oil before fitting it: this enables the recommended oil level to be maintained without topping up.

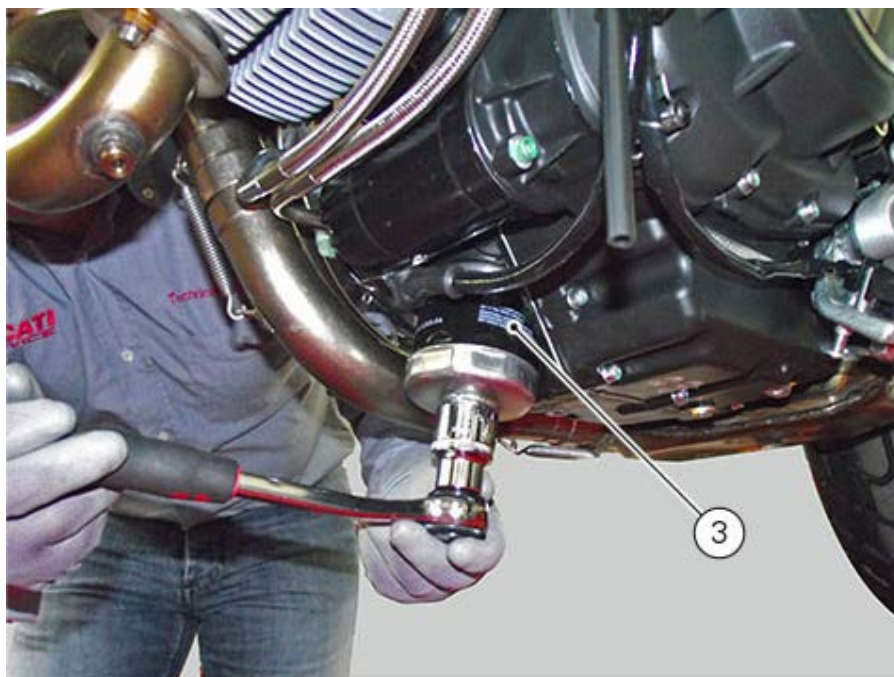

Screw it into relevant seat and tighten it to 11 Nm (Min. 10 Nm - Max. 12 Nm).

Mesh filter

Every two oil changes, clean the oil intake mesh filter.

Remove the exhaust system ([Removing the exhaust system](#)).

Loosen outer plug (4) and collect seal (5).

Loosen the filtering element (6) and slide it out.

Clean the filter with fuel and compressed air. Take care not to damage the mesh. Refit mesh filter (6), seal (5) on plug (4) and tighten it to a torque of 42 Nm (Min. 38 Nm - Max. 46 Nm).

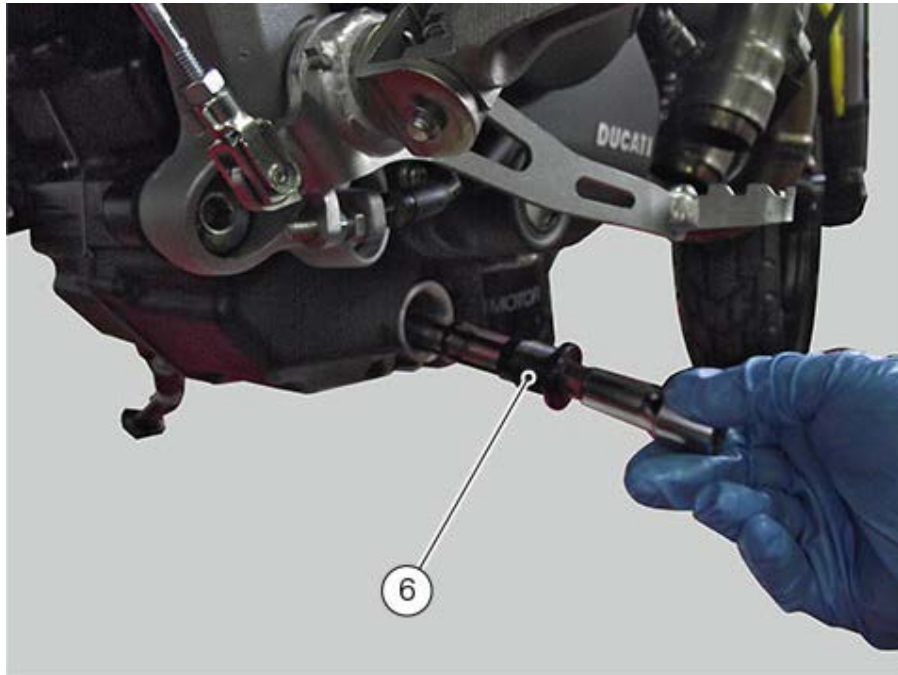
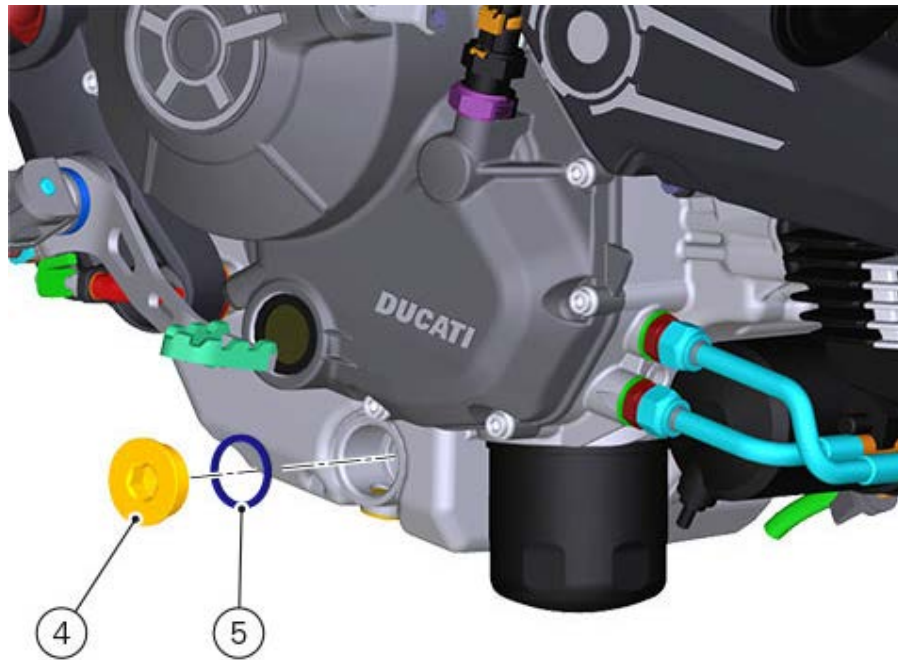

Restore proper engine oil level.

Remove the filler plug (2) and carry out refilling with the specified oil type up to reaching the notch that identifies the MAX level in the sight glass (7).

Refit the filler plug (2). Run the engine at idle speed for a few minutes.

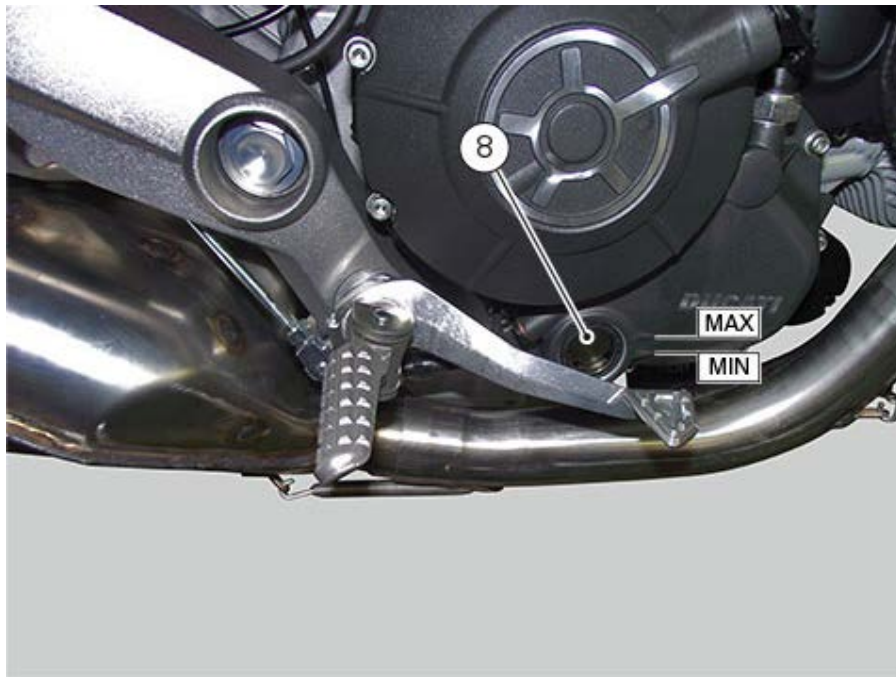
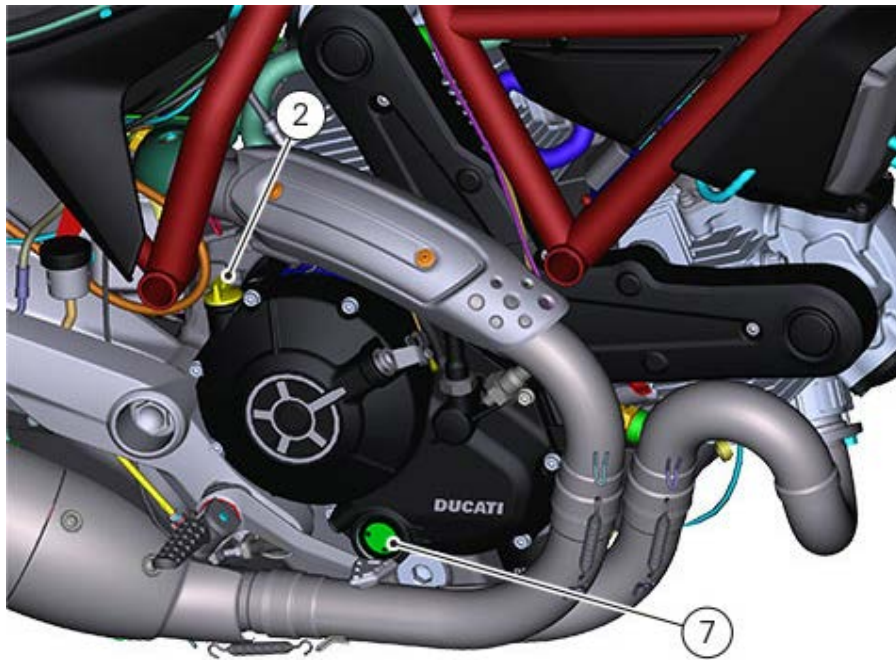

Check that there are no oil leaks and that the relevant warning light on the instrument panel switches off a few seconds after starting up the engine.
If not, stop the engine and trace the fault.
After a few minutes, check that the oil level is the specified one; if necessary, restore the MAX. level (8).
Refit any removed parts.

Check engine oil level

Check the engine oil level through the sight glass (1) on the right-hand side of the oil sump.

Stop the engine and allow a few minutes for the oil to settle to a steady level.

Oil level must be checked with the vehicle perfectly upright and the engine hot (but off). Oil level must be between the MIN and MAX marks.

Top up if the level is low. Remove the filler plug (2) and top up with the recommended oil.

Refit the filler plug (2).

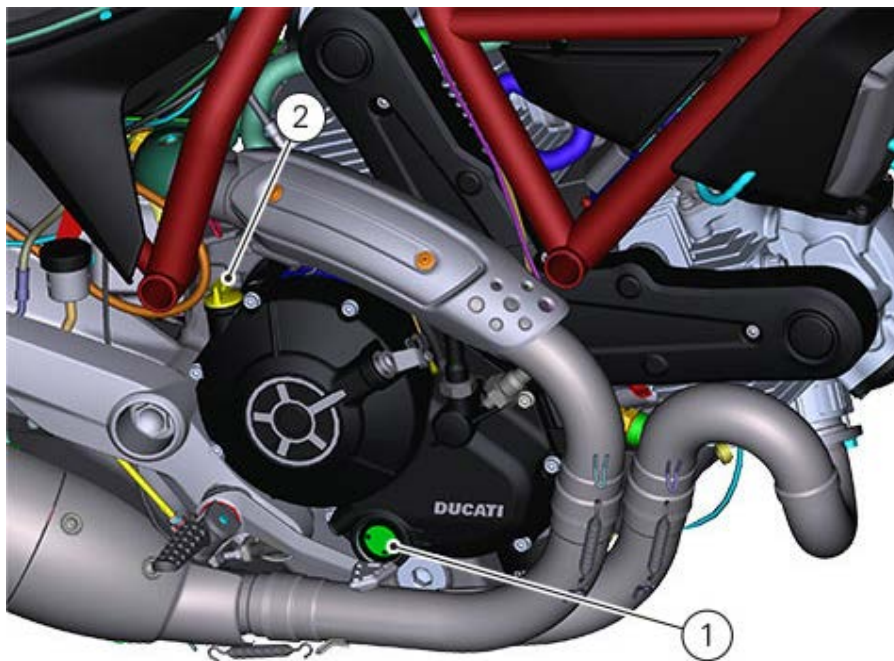
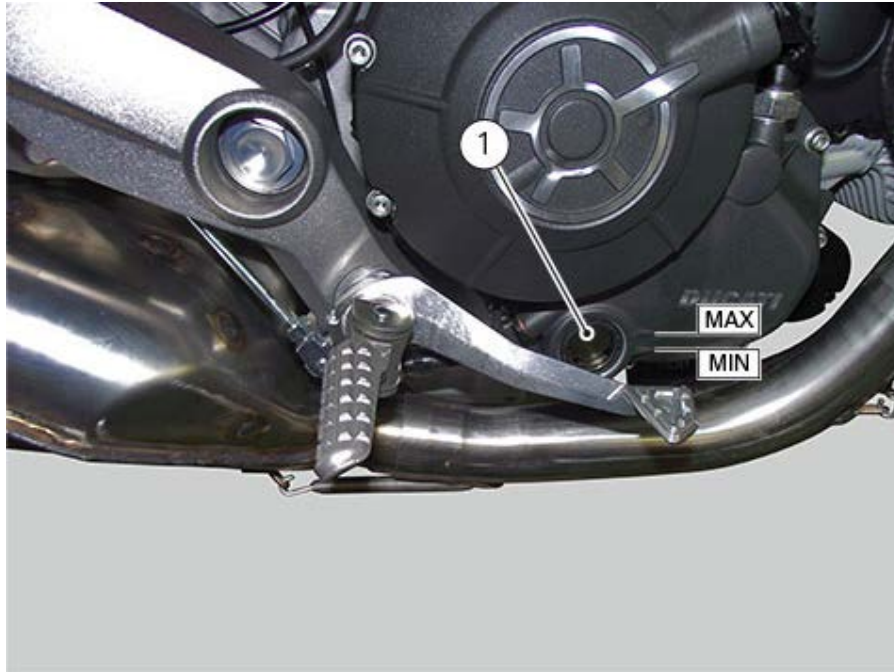

Refitting the rear-view mirrors

Position the RH mirror (2) with nut (1) on the U-bolt.
Screw the RH rear-view mirror (2) in the indicated direction until reaching the required position.
Then, keeping the rear-view mirror in its position, tighten nut (2), always in the indicated direction, to a torque of $25 \text{ Nm} \pm 10 \%$.

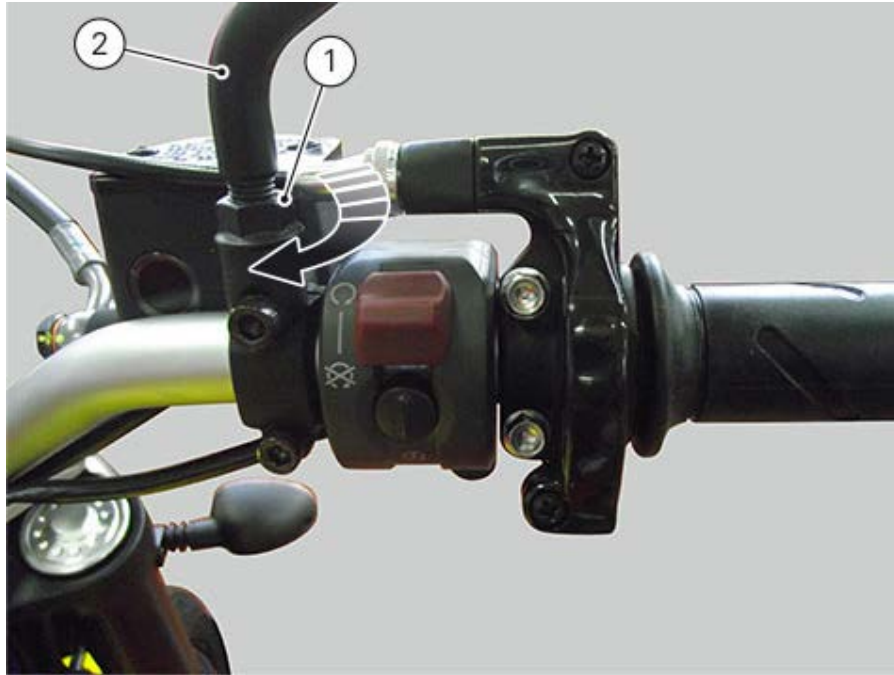

Removing the rear-view mirrors

Loosen nut (1) in the direction shown in the figure.
Loosen the rear-view mirror (2).

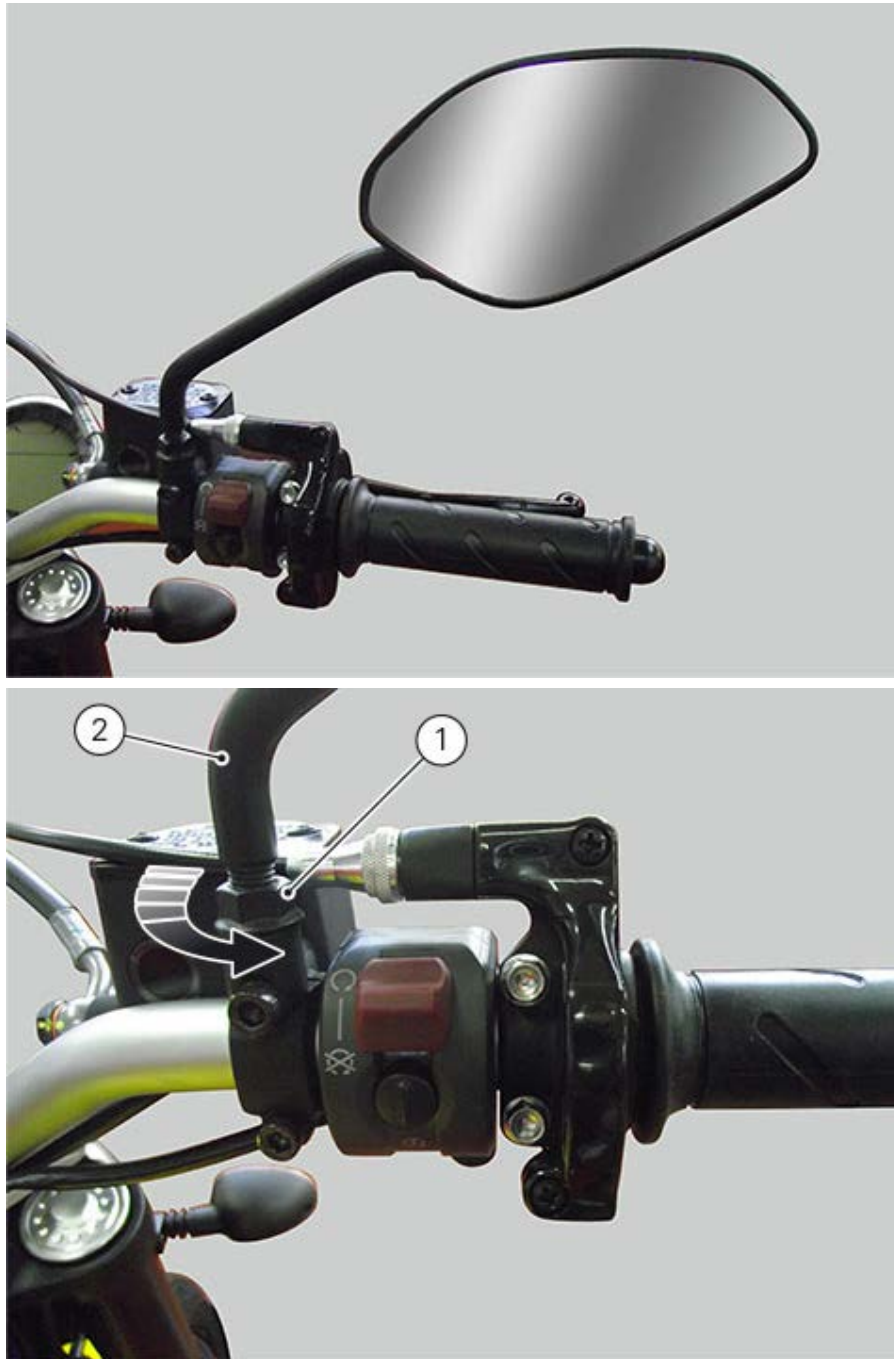

Follow the same procedure with the LH mirror.

Refitting the tail guard

Check that clips (7) are fitted on mudguard support frame (5).



Fix the two turn indicators (8) with screws (9).

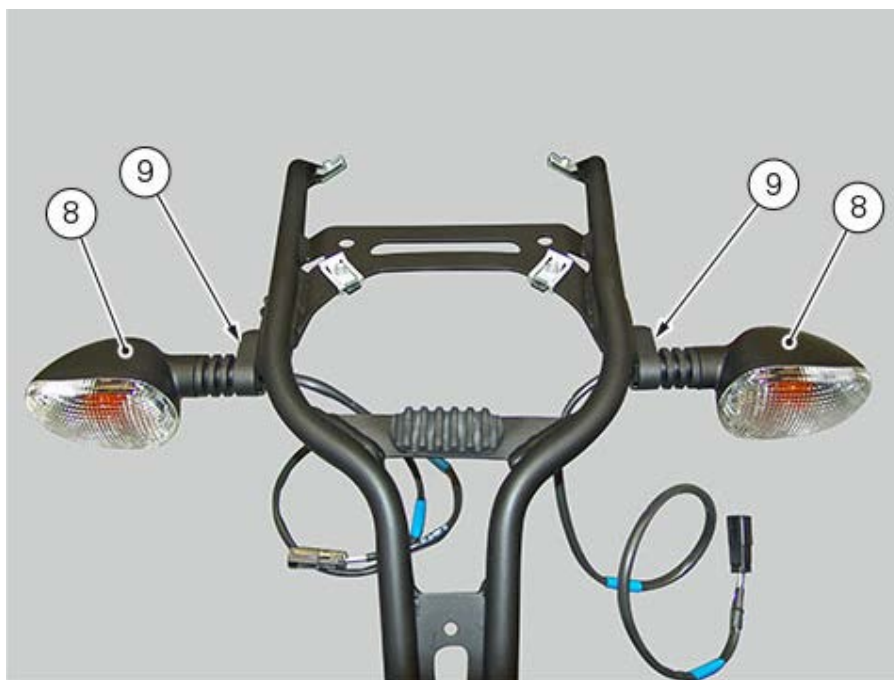

Position splash guard (10) on frame (5) and fix it with screws (11).

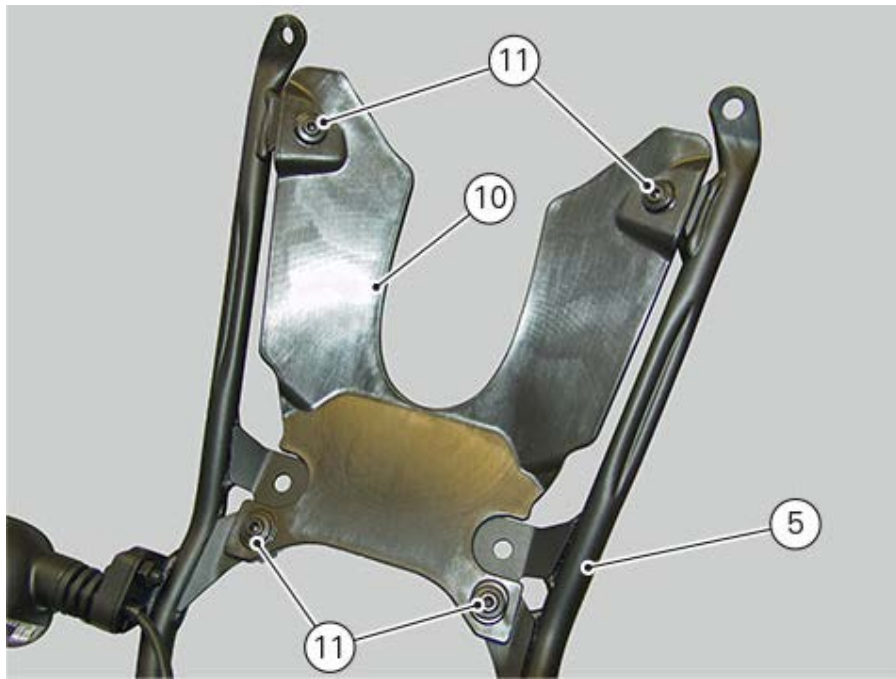

Fit cat's eye (12) and fix it with two nuts (14) with washer (13).



Position number plate light (16) by inserting cable (15) in frame (5) as shown in the figure.

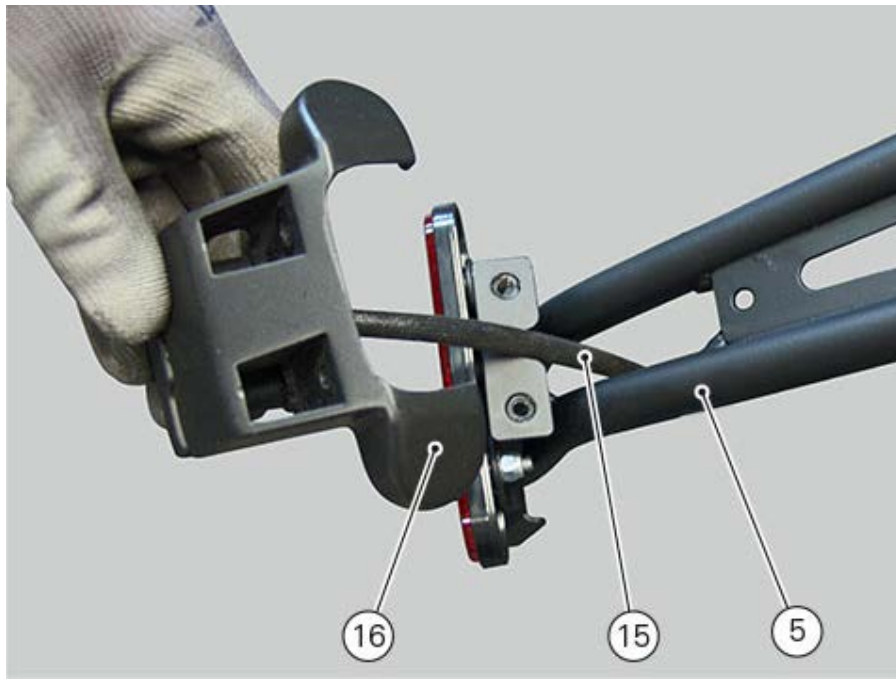

Fix the number plate light (16) by means of screws (17).

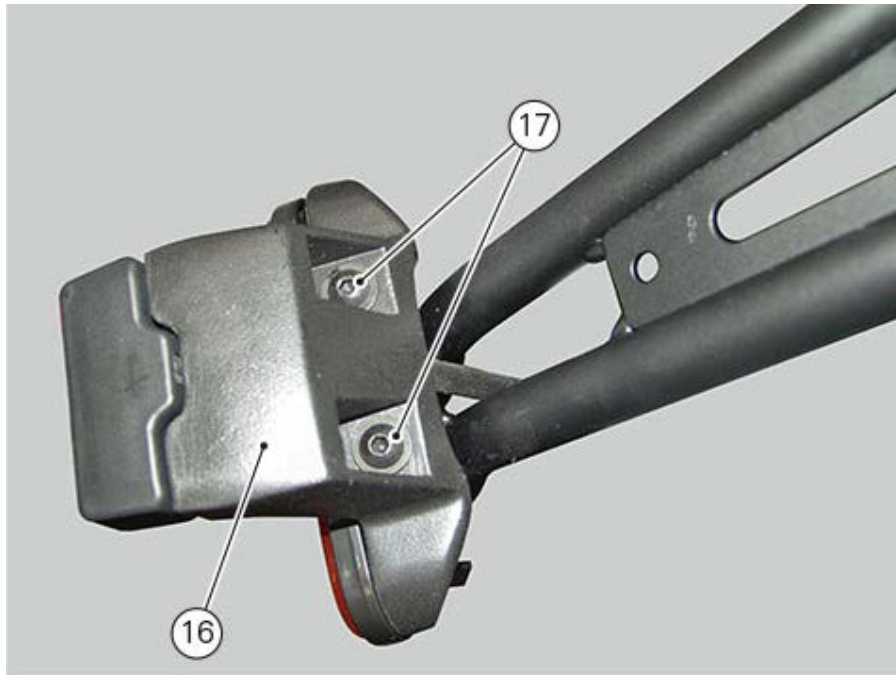

Position the wiring with ties as shown in the figure.

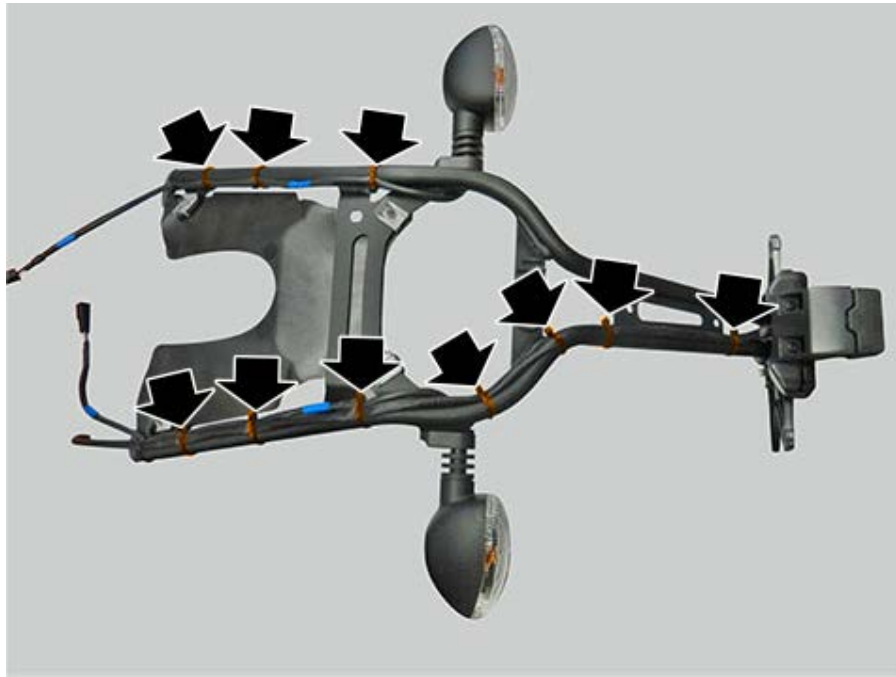

Fit mudguard (3) and fix it with screw (6).

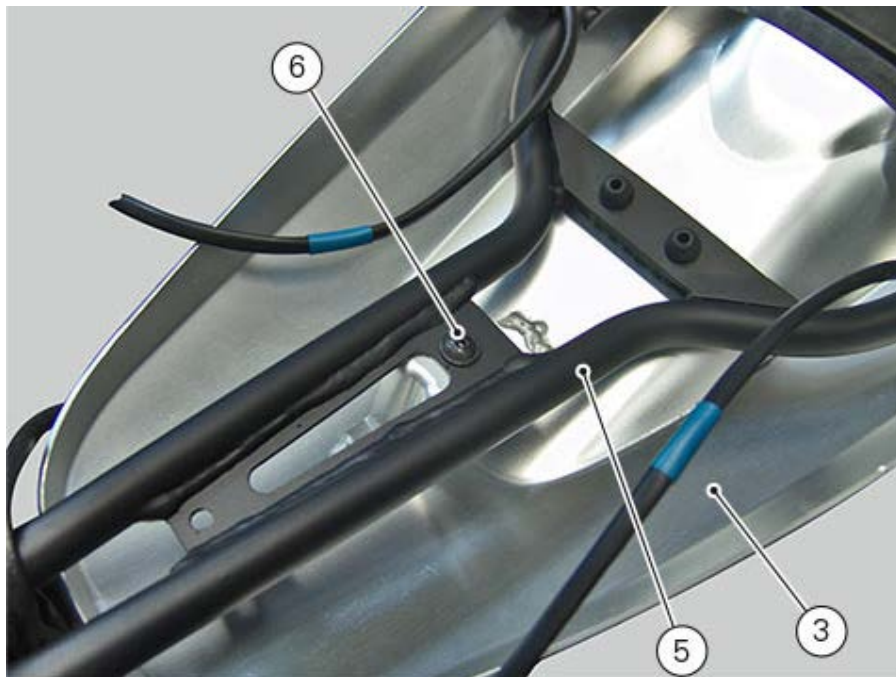

Position the rear subframe/mudguard assembly on the vehicle.
Start screws (4).

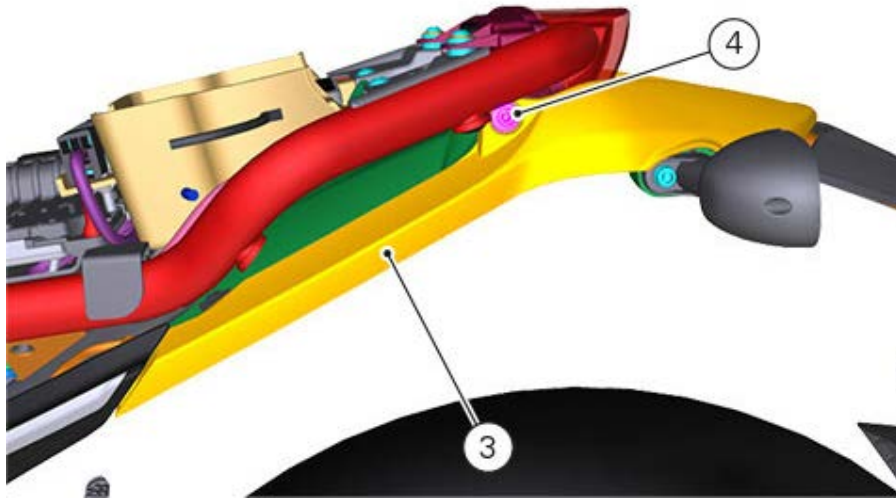

Working on the lower side, start screws (1) and (2).
Tighten screws (4), (1) and (2).

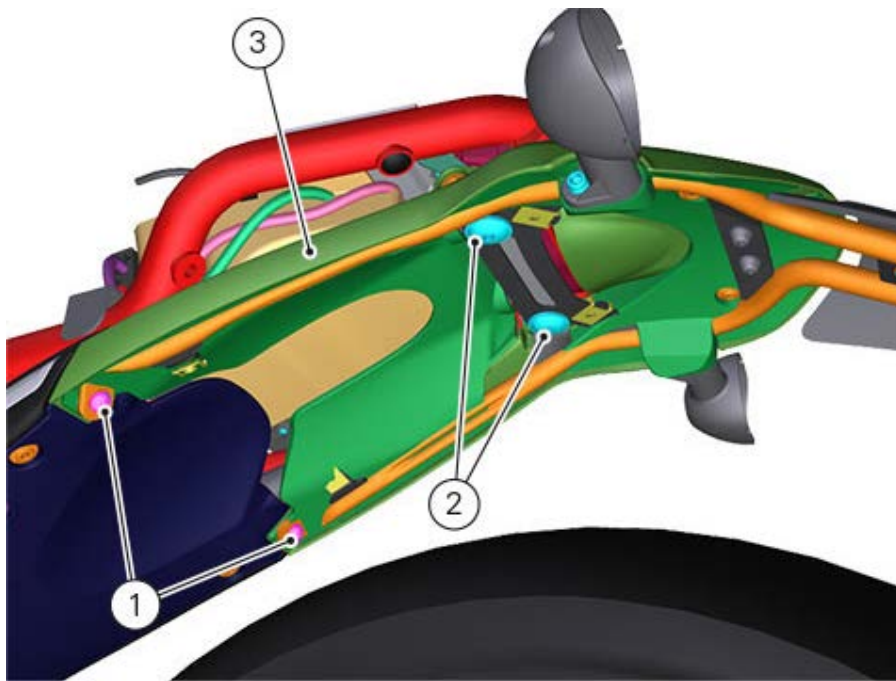

Connect the turn indicator and number plate light connectors.

Removing the tail guard

Disconnect the turn indicator and rear number plate connectors.
Remove screws (1) and (2) located on the lower side of the rear mudguard (3).

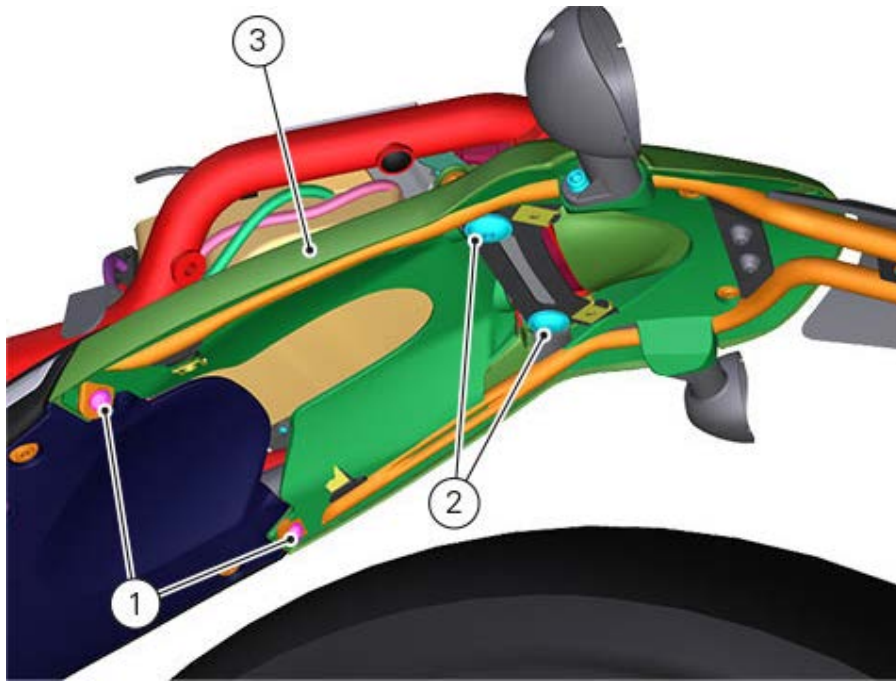

Remove screws (4) that retain the rear mudguard (3) on both sides of the vehicle.
Remove the frame/mudguard assembly.

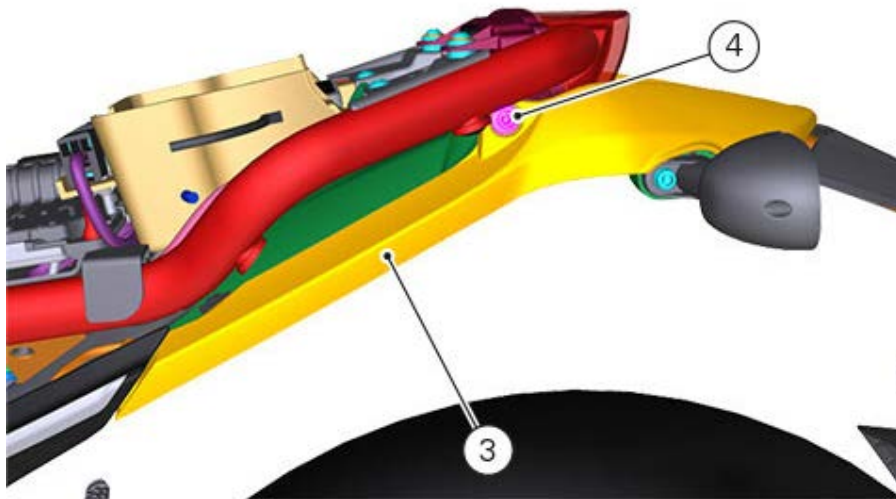

Remove screw (6) to remove the rear mudguard (3) from its frame (5).

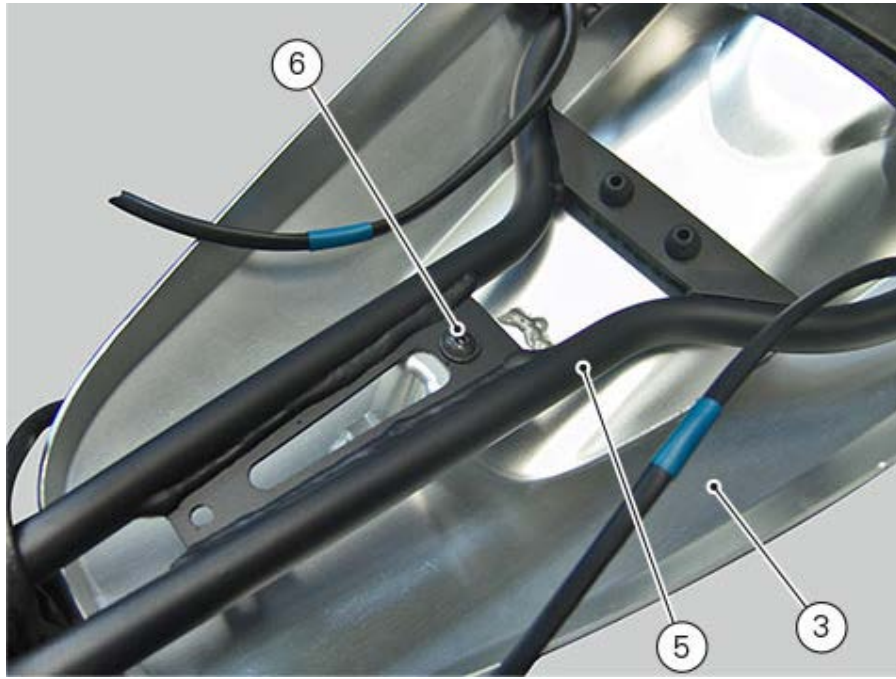

Refitting the seat release mechanism

Insert lock (7) in the relevant hole of the underseat cover.
Fit tabs (8) and (9) into the relevant recesses on the cover.

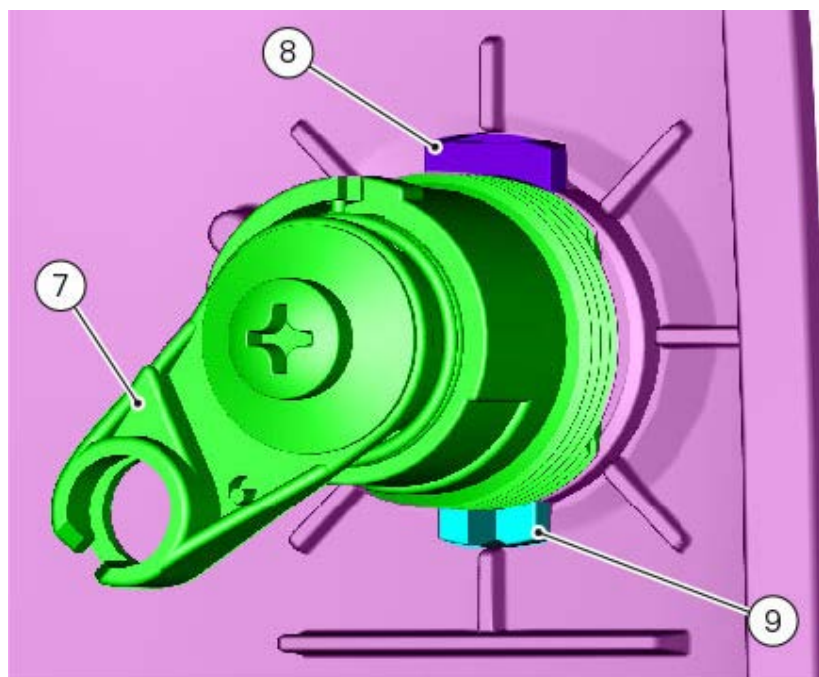

Insert plate (10) on inner side of the underseat cover aiming it as shown in the figure.
There is just one possible position because of elements (11) and (12).

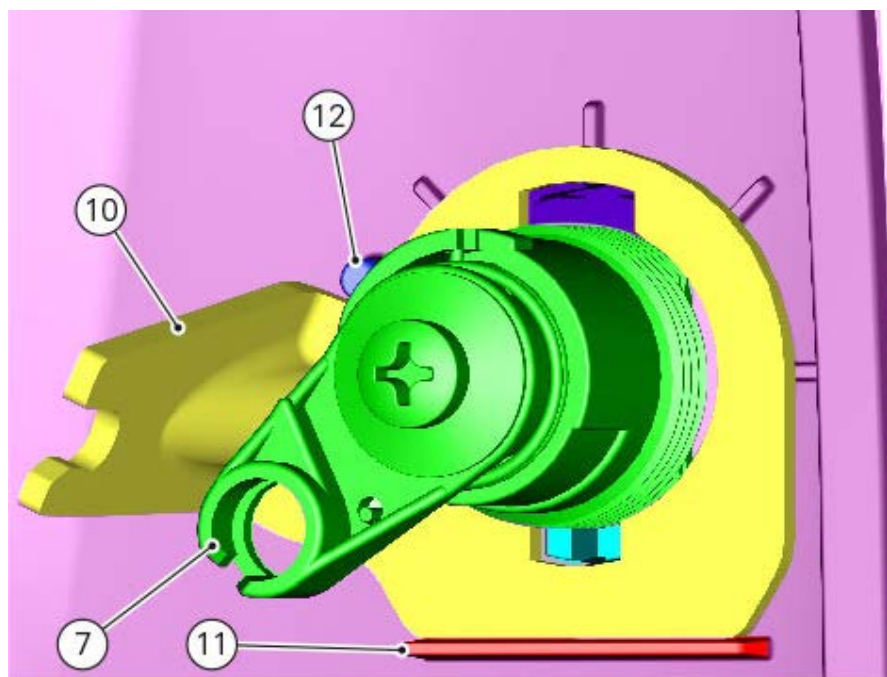

Fit lock (7) by tightening nut (6) to a torque of $3 \text{ Nm} \pm 10\%$.

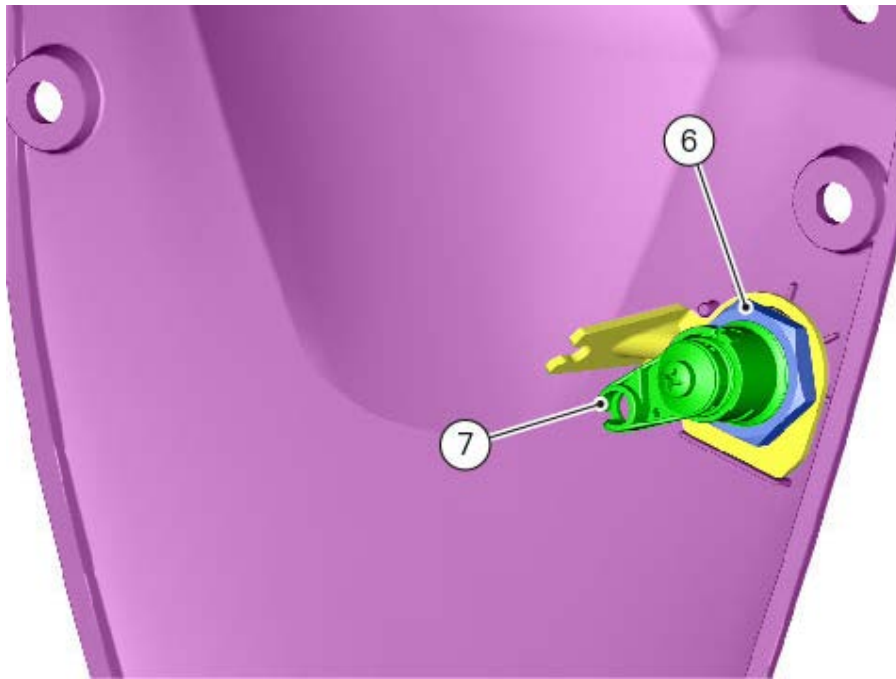

Fit nipple (3) into its seat (4).

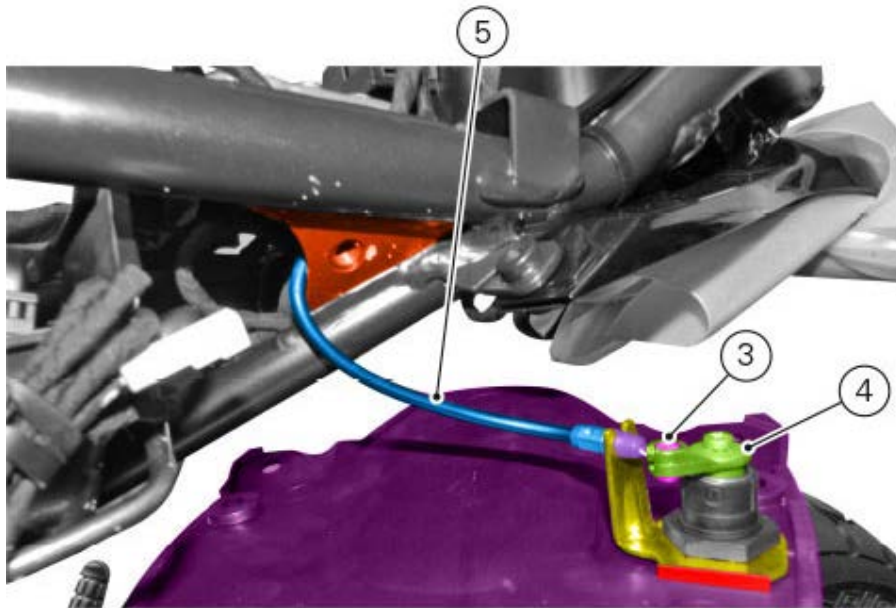

Position the underseat cover (1) and fix it by means of screws (2).

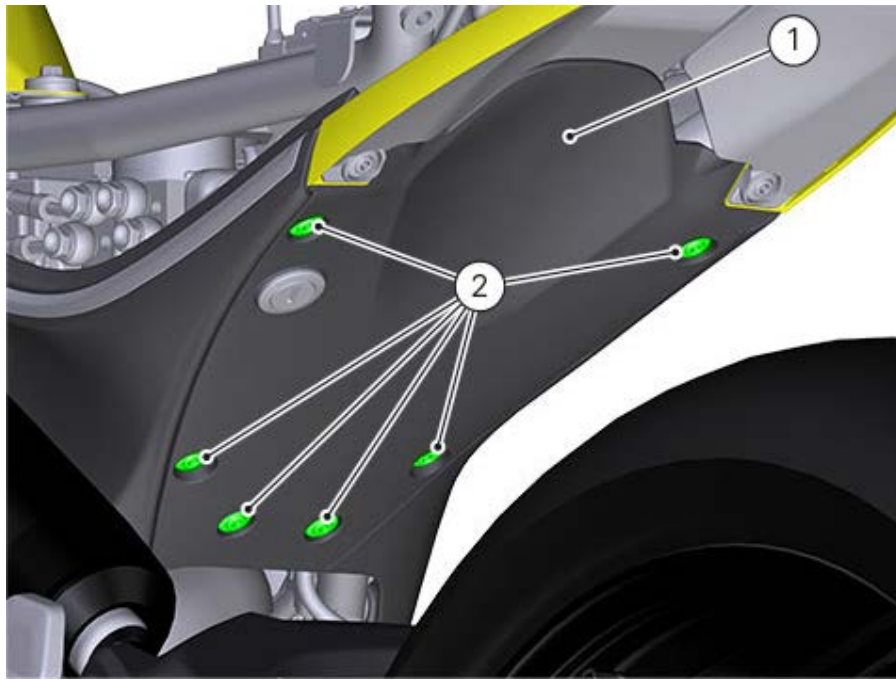

Removing the seat release mechanism

Remove the underseat cover (1), loosening screws (2).

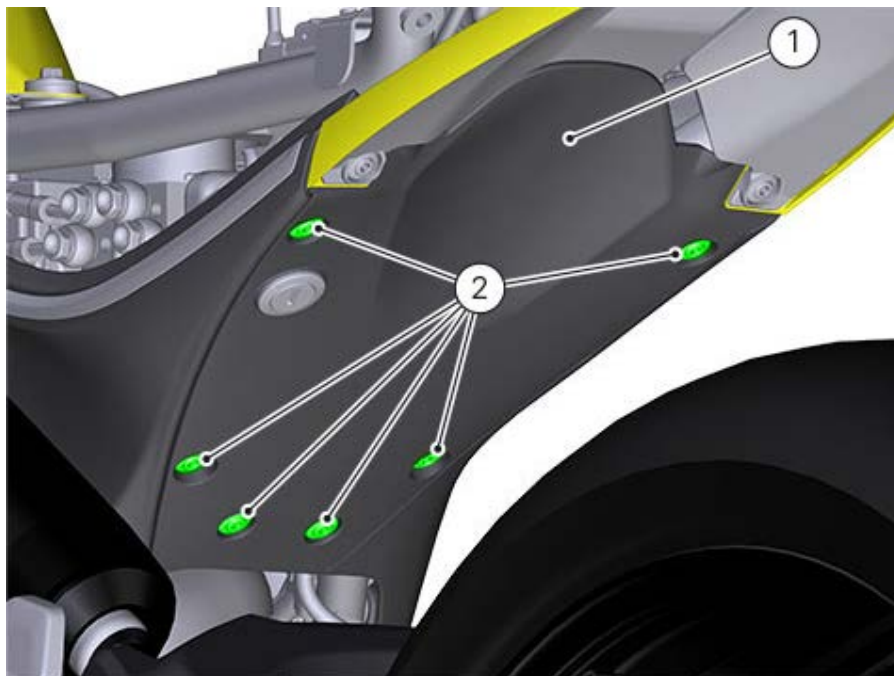

Remove nipple (3) from its seat on the lock lever (4).
Release lock lever cable (5).

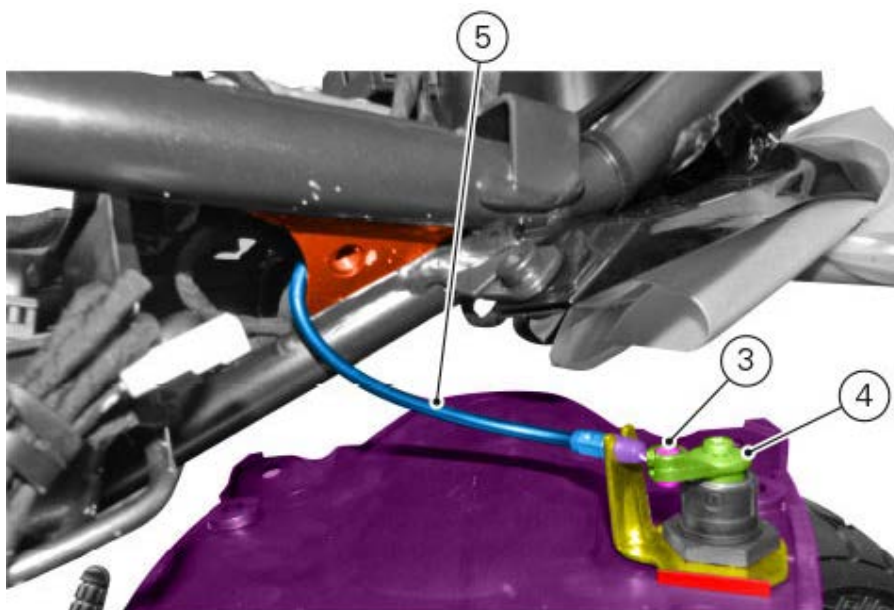

Unscrew nut (6) and remove the seat opening device (7).

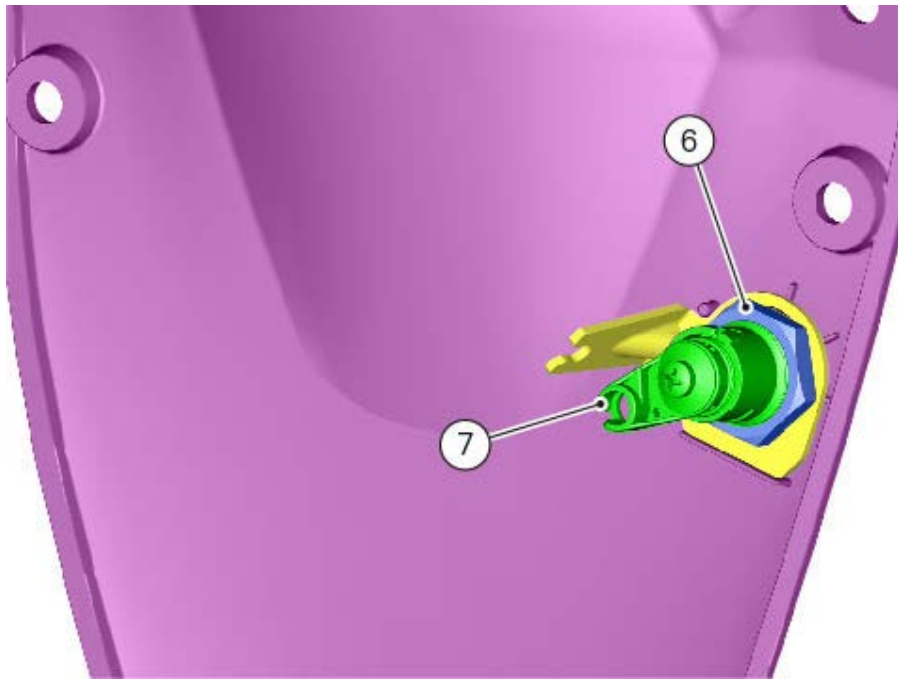

Refitting the tail guard

Reassemble the tail guard as follows:

Check on both sides of the vehicle the presence of the two retaining clips (16).

Fasten the two turn indicators by tightening screws (17) to the torque of $5 \text{ Nm} \pm 10\%$.

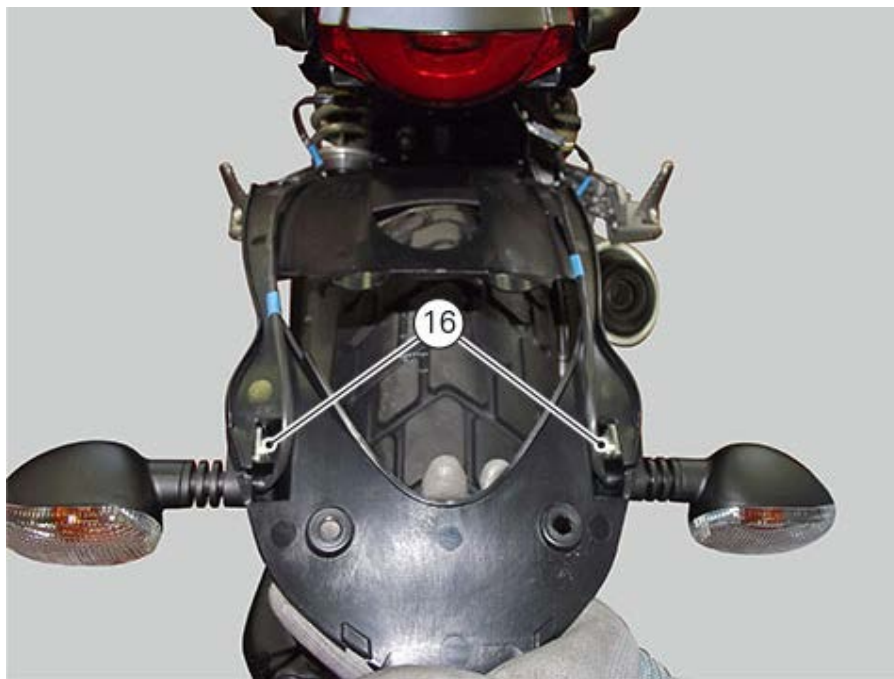
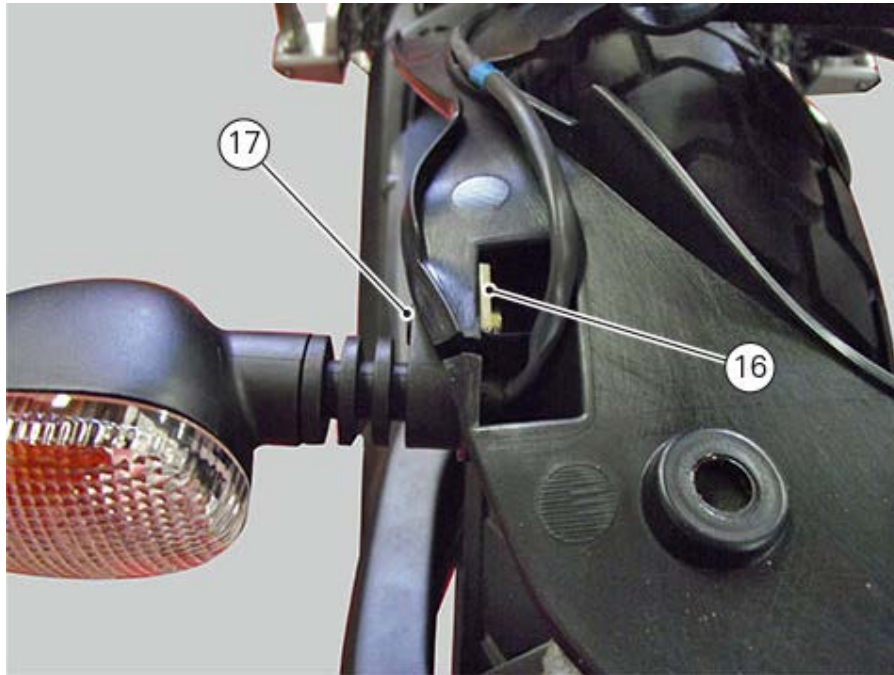

If previously removed, join the tail guard upper part (13) with the lower part (14) using the two screws (15).

Tighten the two screws (15) to a torque of $5 \text{ Nm} \pm 10\%$.

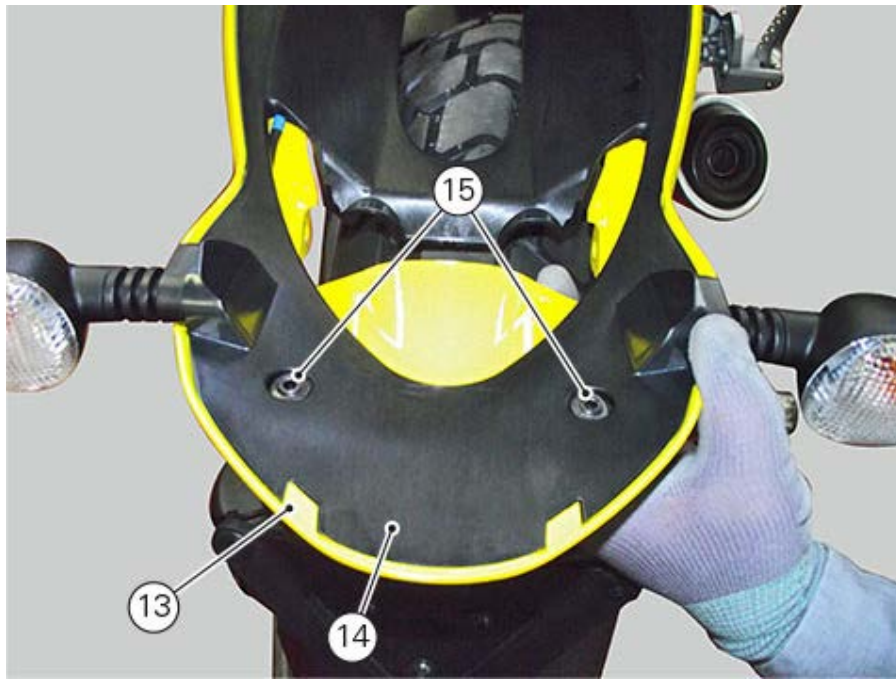

Connect the two turn indicator connectors (11) and (12).

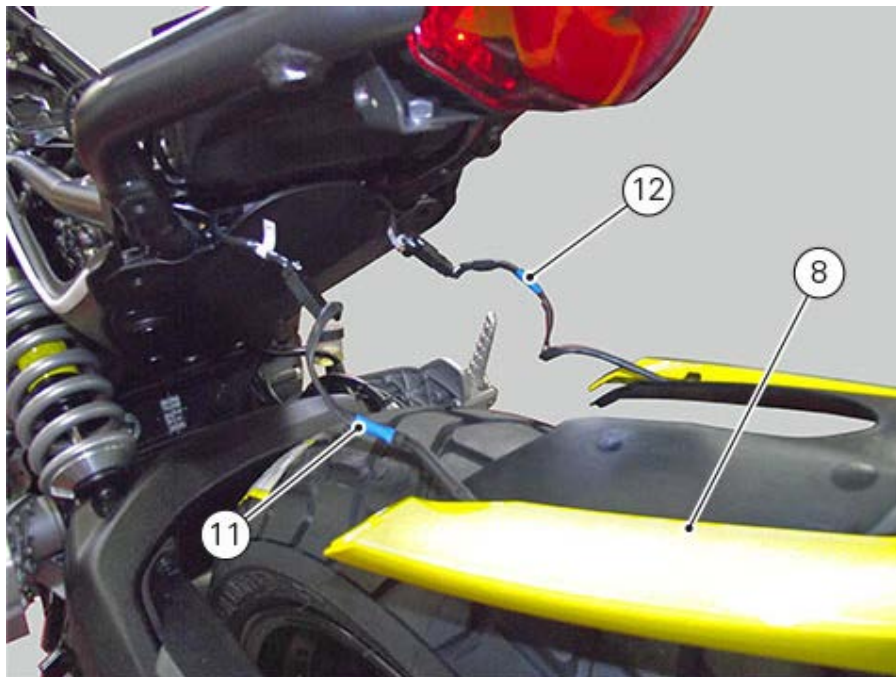

Position tail guard (8) on the frame and start the two screws (9) and (10).
Make sure that washers (18) are present on the screws.

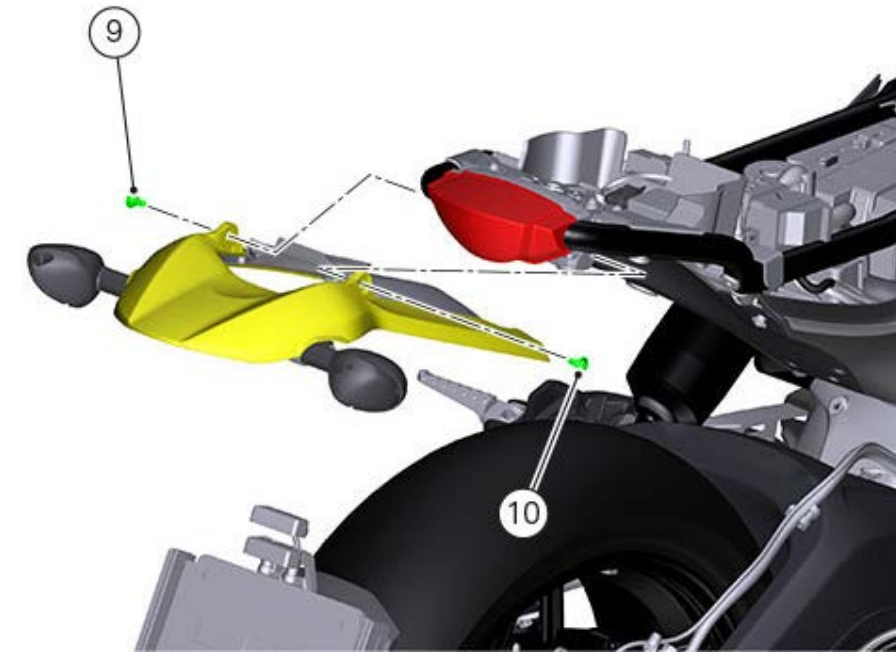



Start the two screws (7) in the tail guard lower side.

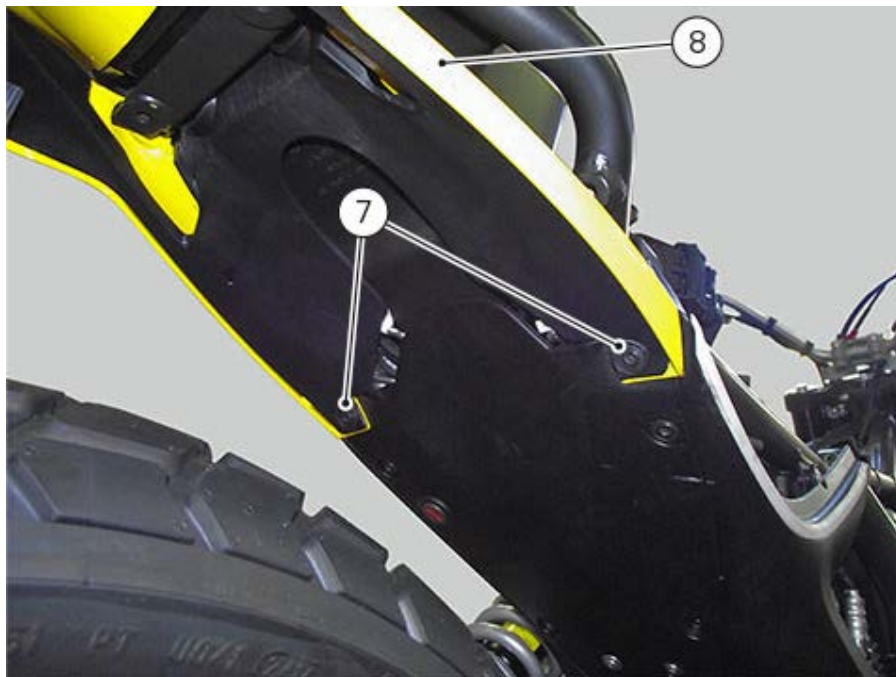

Tighten the screws (9) and (10) to a torque of $5 \text{ Nm} \pm 10\%$ and the screws (7) to a torque of $8 \text{ Nm} \pm 10\%$.

Removing the tail guard

Remove the two lower screws (7) of tail guard (8).

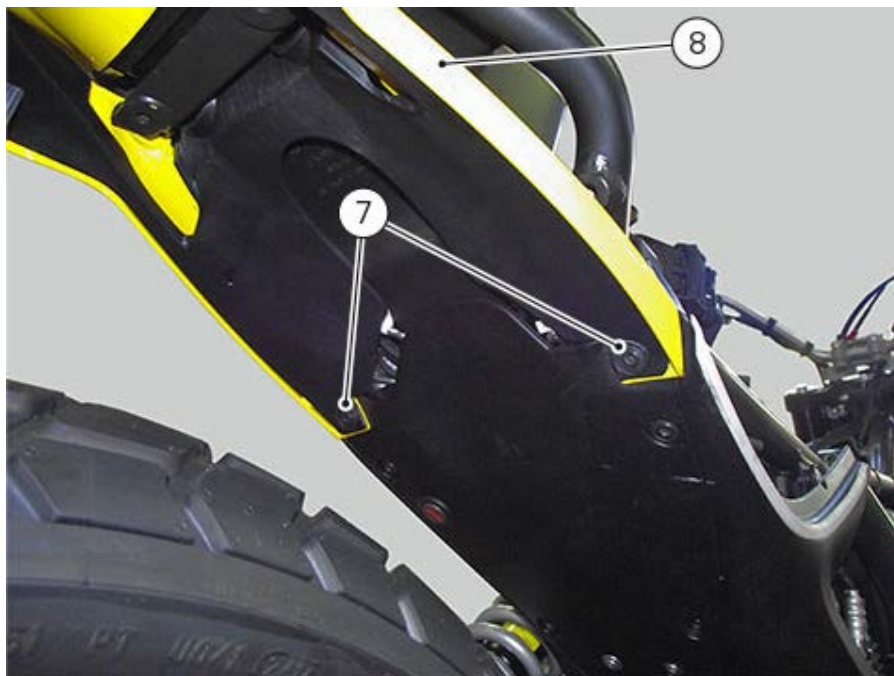

Remove the two lateral screws (9) and (10).





Separate tail guard (8) from the frame and disconnect the connectors of RH (11) and LH (12) turn indicators.
Remove tail guard (8).

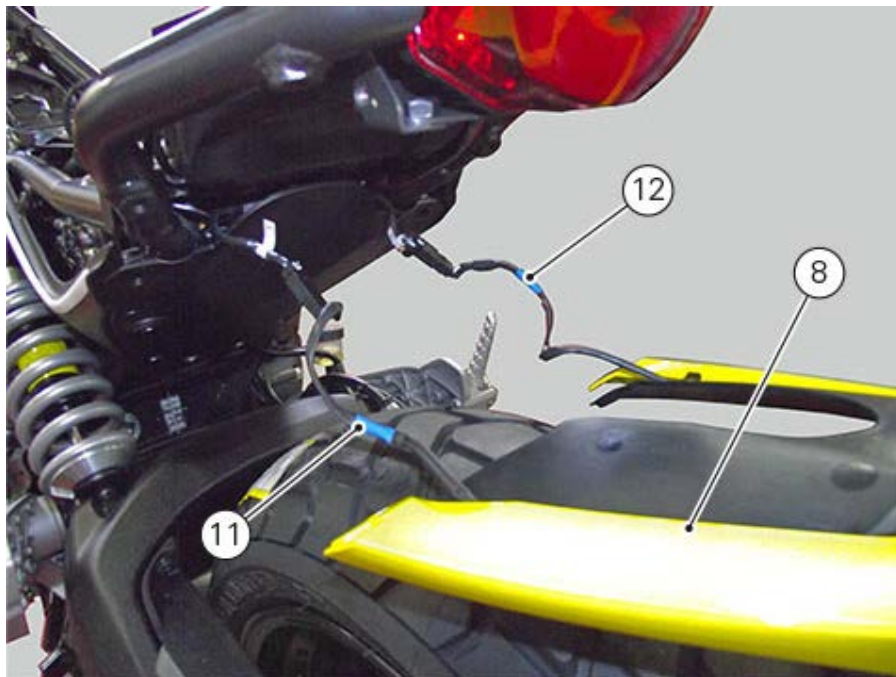

To disassemble the tail guard, proceed as follows:
Loosen the two screws (15) and separate the tail guard upper part (13) from the lower part (14).

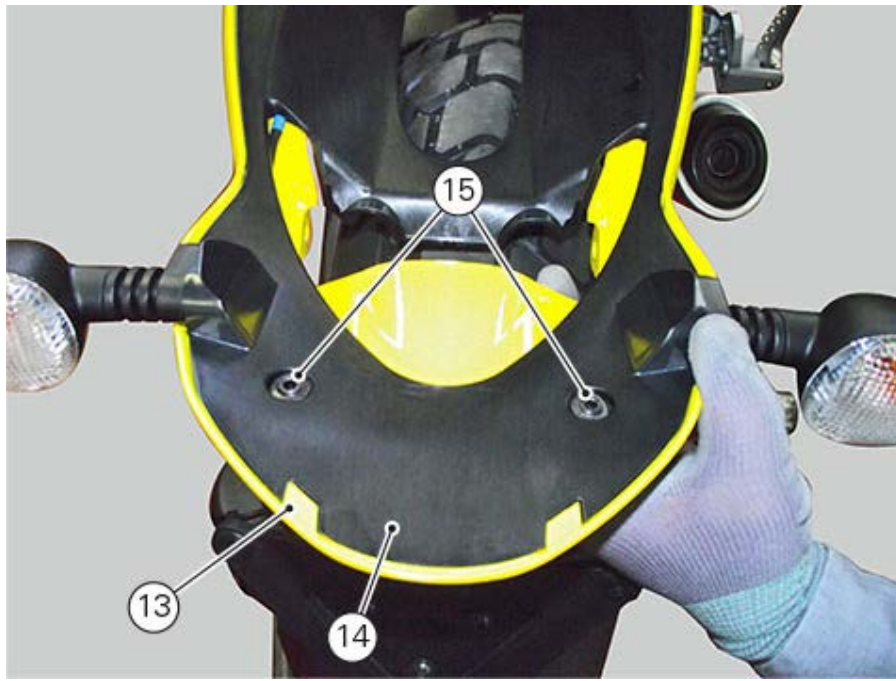

Refitting the rear side body panels

Check the presence of the two clips (19) on the two side body panels.

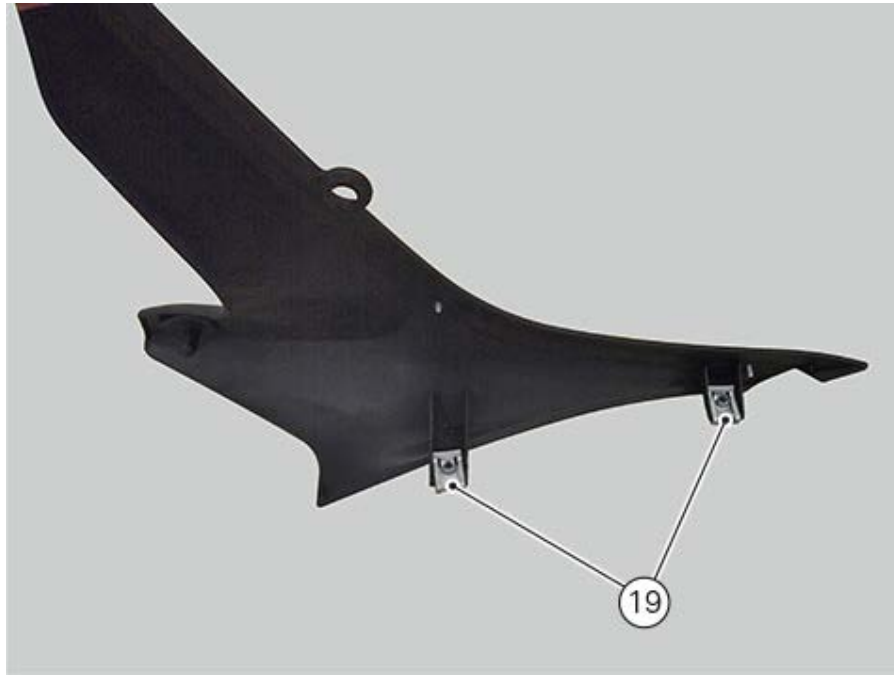

If not already present on the side body panels, fit trims (20) fully home by inserting the three pins (21) in the relevant holes with retainers (A) on the side body panels.

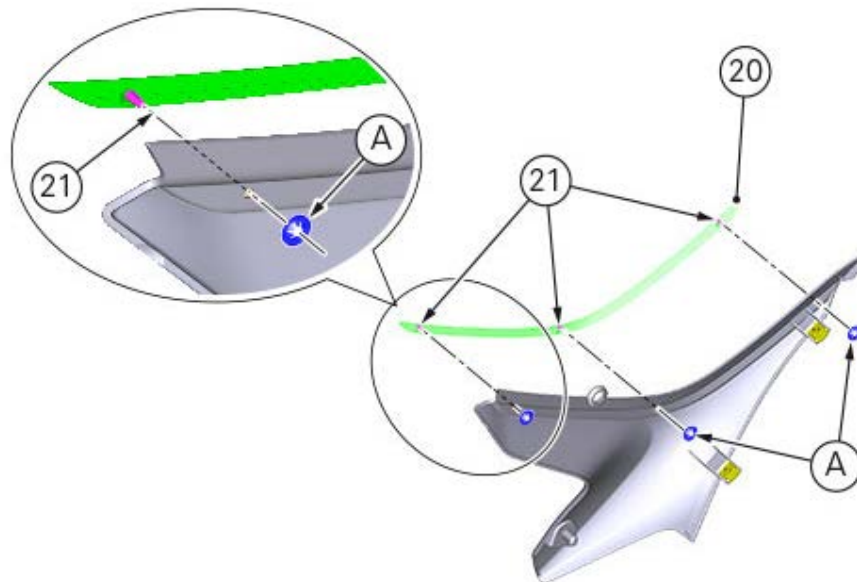

RH side body panel

Position the RH side body panel (3) inserting pin (19) fully against rubber block (20).

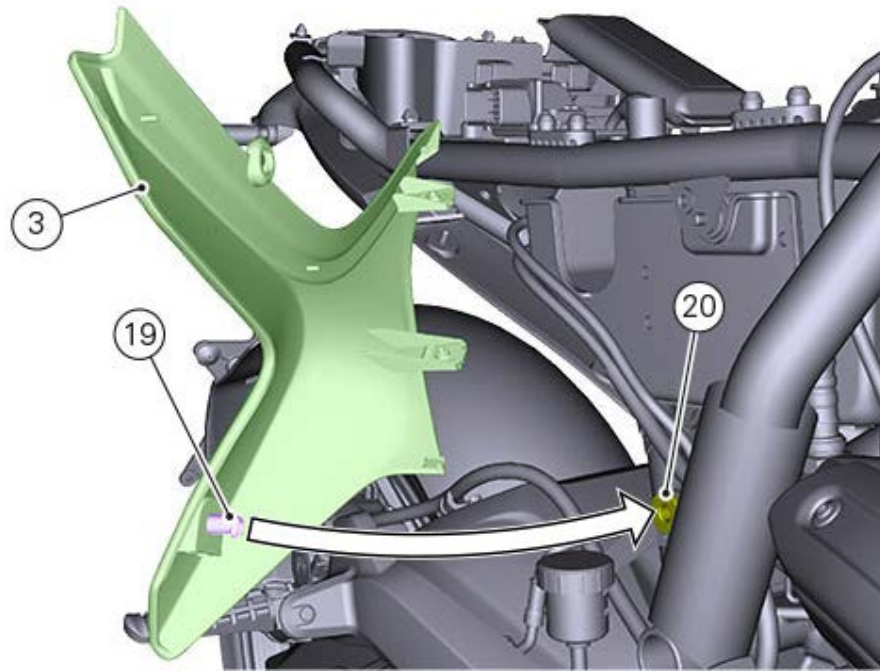

Start screw (1) with washer (22) on RH rear side body panel (3).
Start lower screws (2).

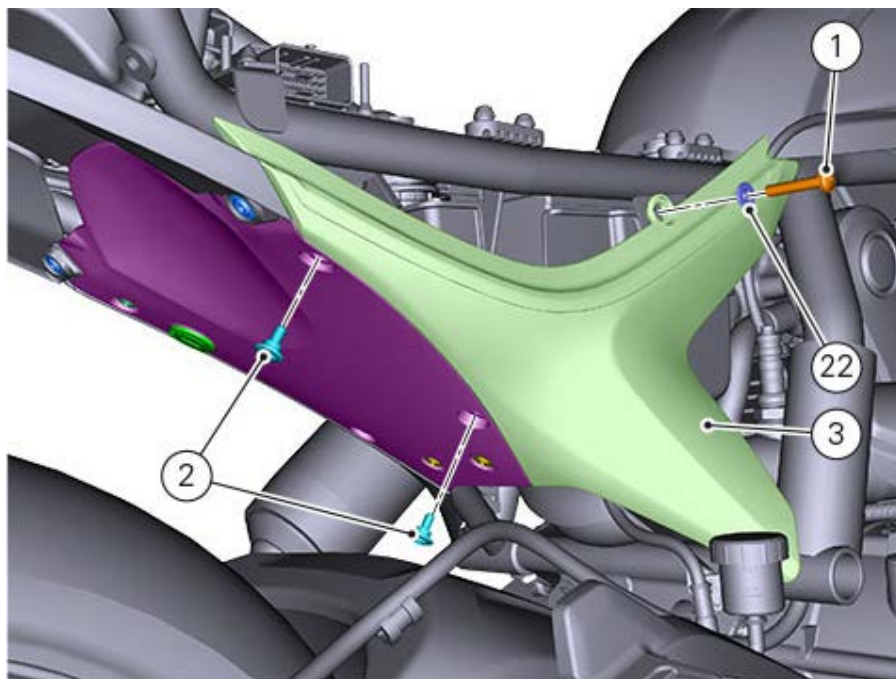

Tighten screw (1) with washer (22) and the two screws (2) to a torque of $8 \text{ Nm} \pm 10\%$.

LH side body panel

Position the LH side body panel (6) inserting pin (23) fully against rubber block (24).

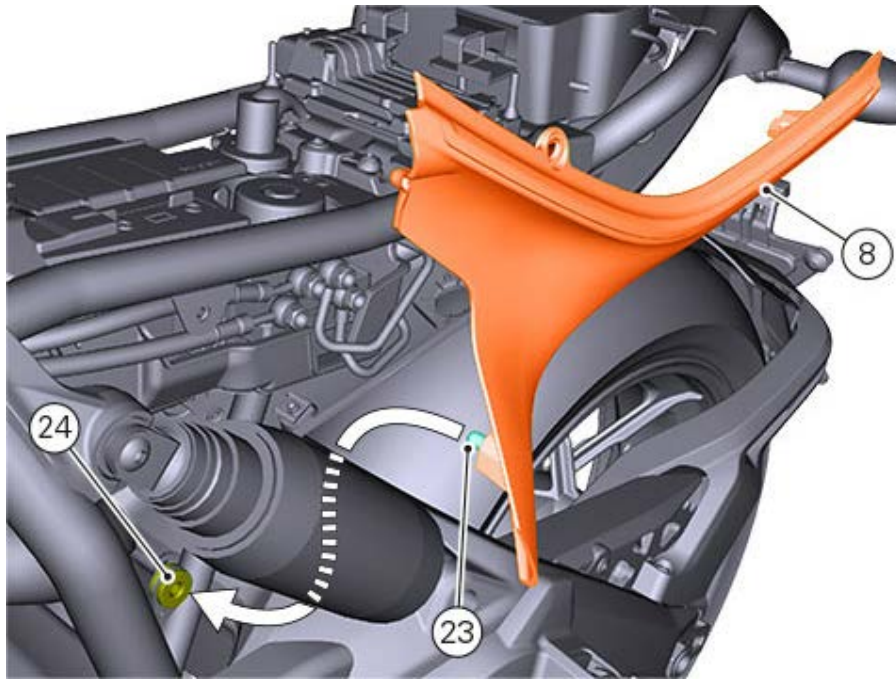

Start screw (4) with washer (25) on LH side body panel (6).
Start lower screws (5).

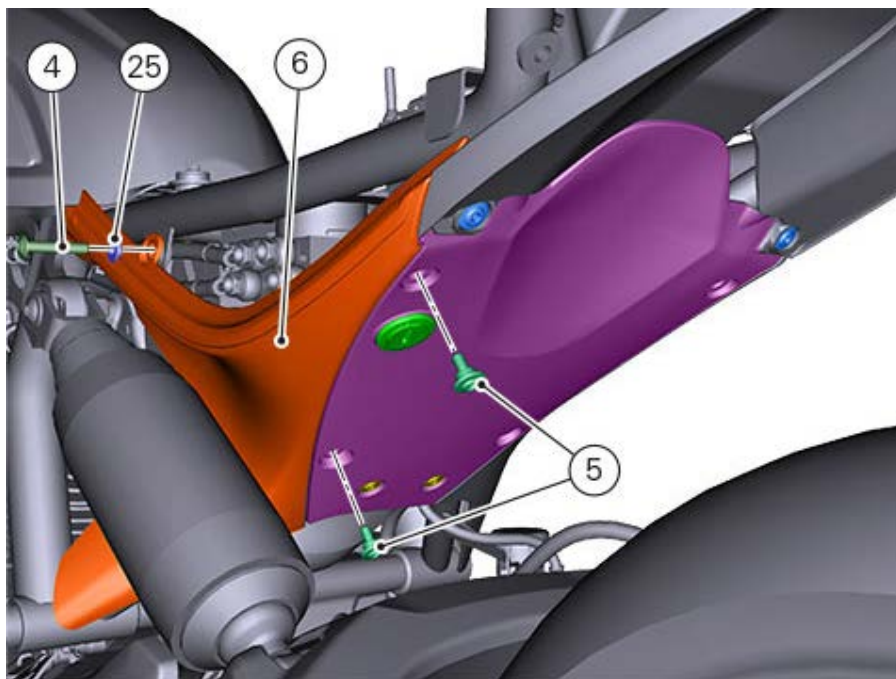

Tighten screw (4) and the two screws (5) to a torque of $8 \text{ Nm} \pm 10\%$.

Removing the rear side body panels

Remove the seat ([Removing the seat](#)).

RH side body panel

Loosen the upper screw (1) and the two rear screws (2) of the underseat side body panel (3).

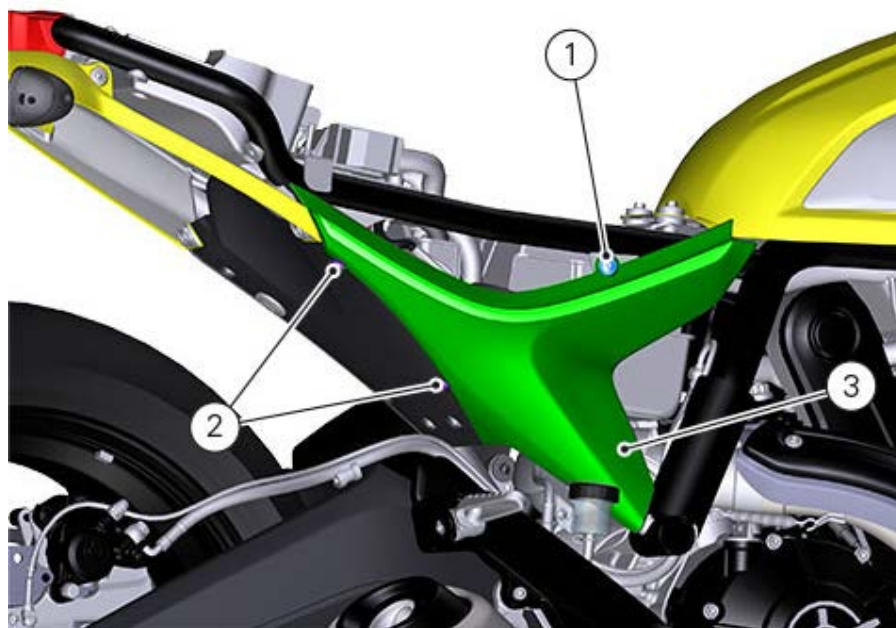



Remove the side body panel by pulling it outwards.

LH side body panel

Loosen the upper screw (4) and the two rear screws (5) of the underseat side body panel (6).

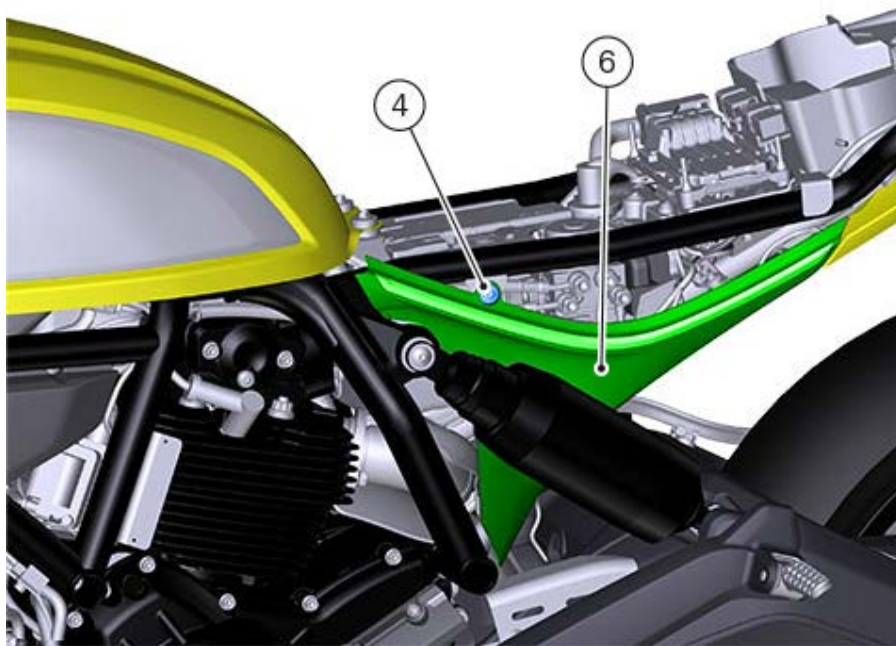

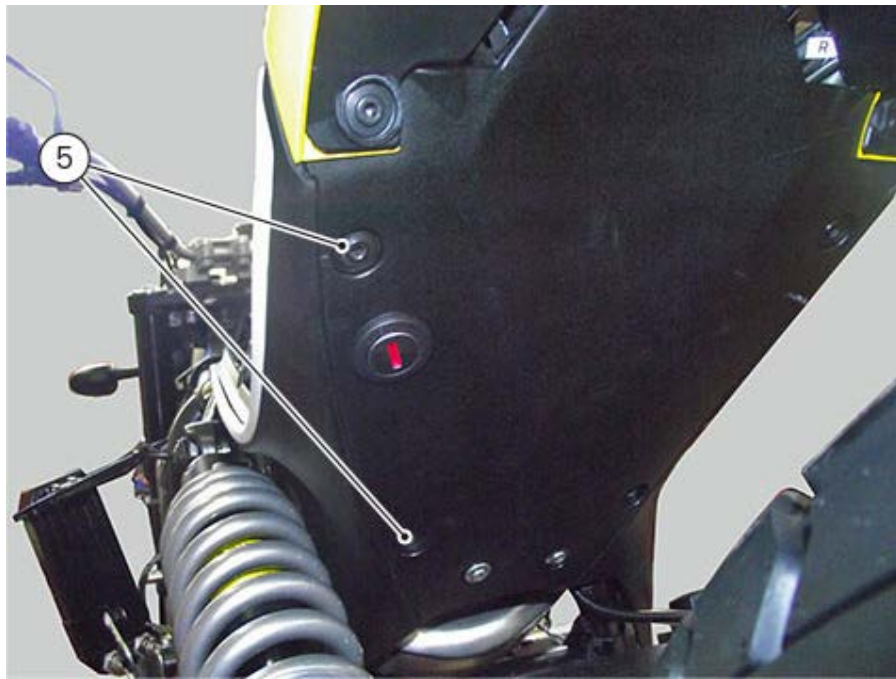

Release the side body panel front side.



Slide out the side body panel by sliding it first downwards and then towards the rear side so as to release it from the shock absorber.



Refitting the seat

Position the rider seat (2) by inserting the front catch (A) under the tank fastener (B), as shown in the figure.

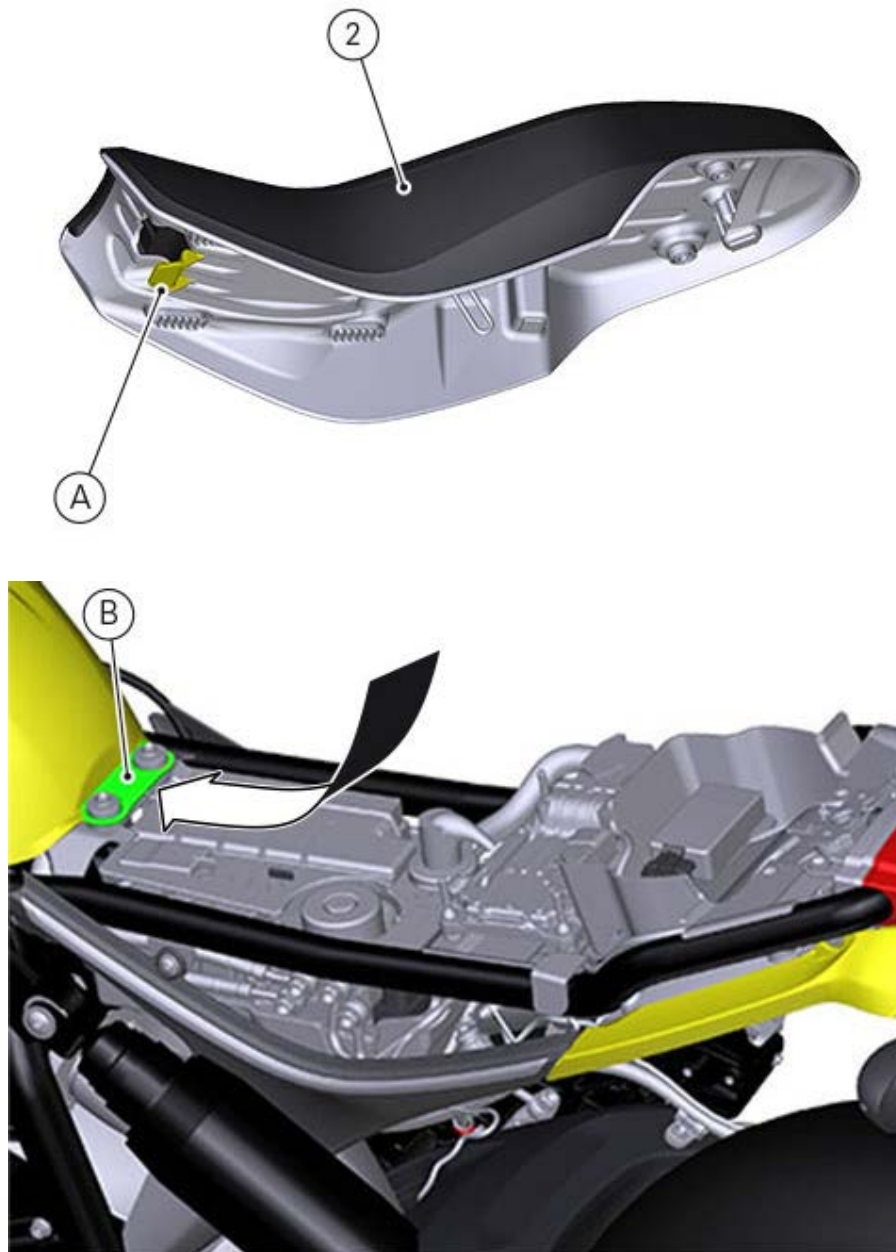

Push the seat rear end until pin clicks in place inside latch.

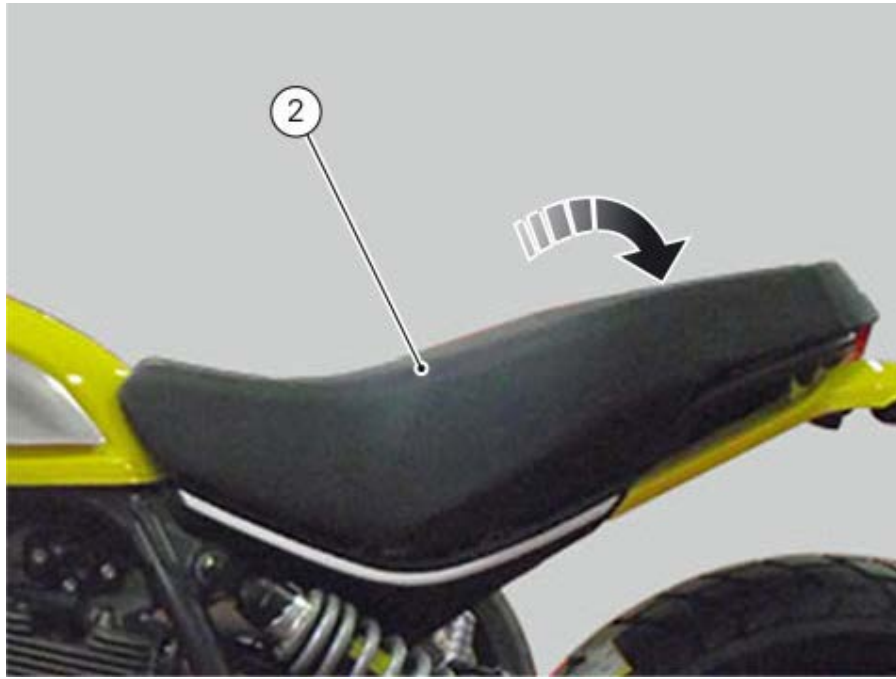

Removing the seat

Insert the key into the catch (1) and turn it clockwise until the latch disengages with an audible click.

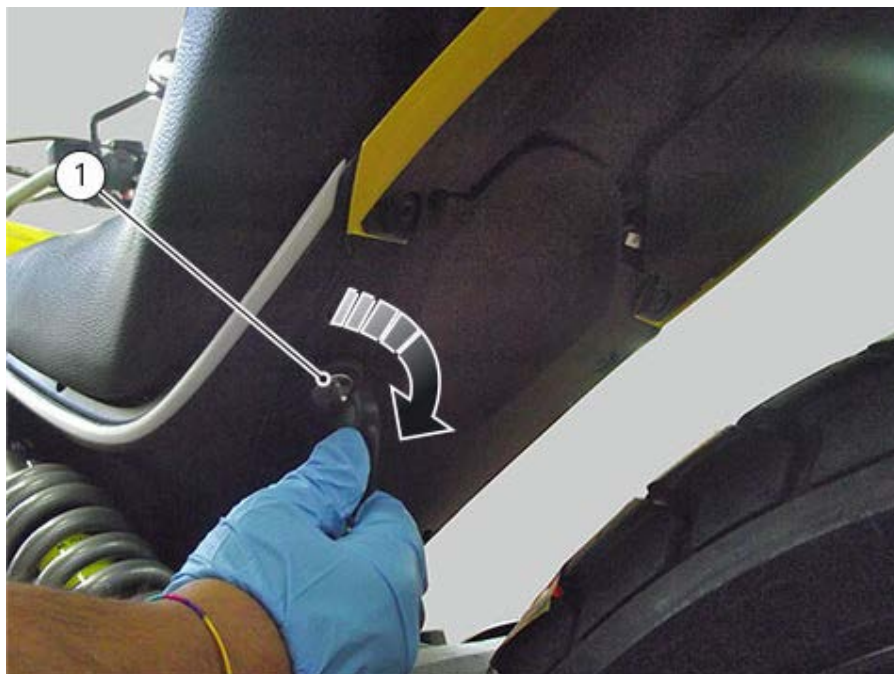

Slide out seat (2) from the front side by lifting it.

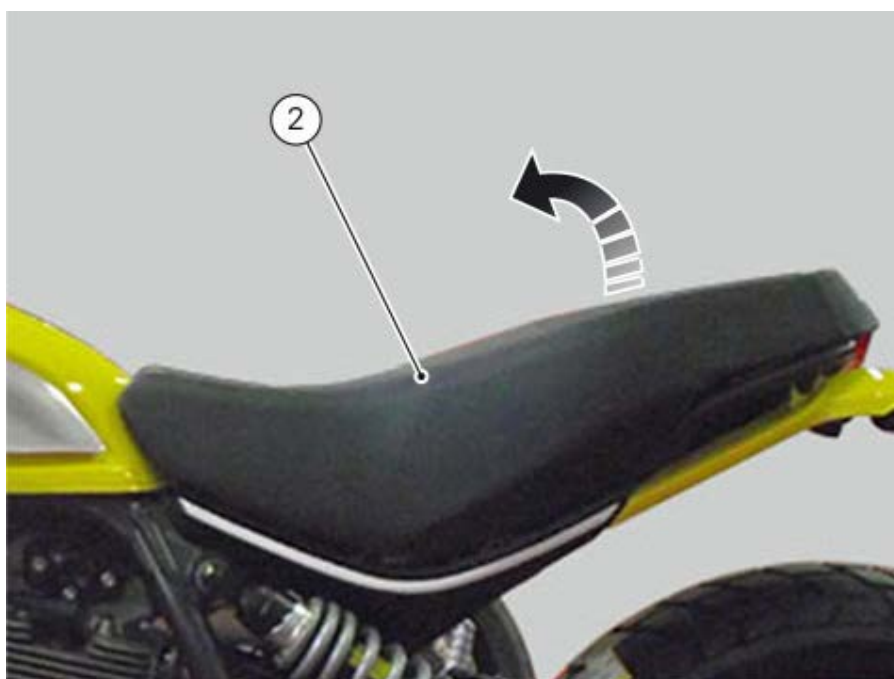

Refitting the front mudguard

Position support (4) in the suitable seats (3) of front mudguard (1).
Fix the mudguard/support to the steering plate (5) by tightening screws (2).
Upon assembly, check the presence of rubber elements (6) and cable support (7).

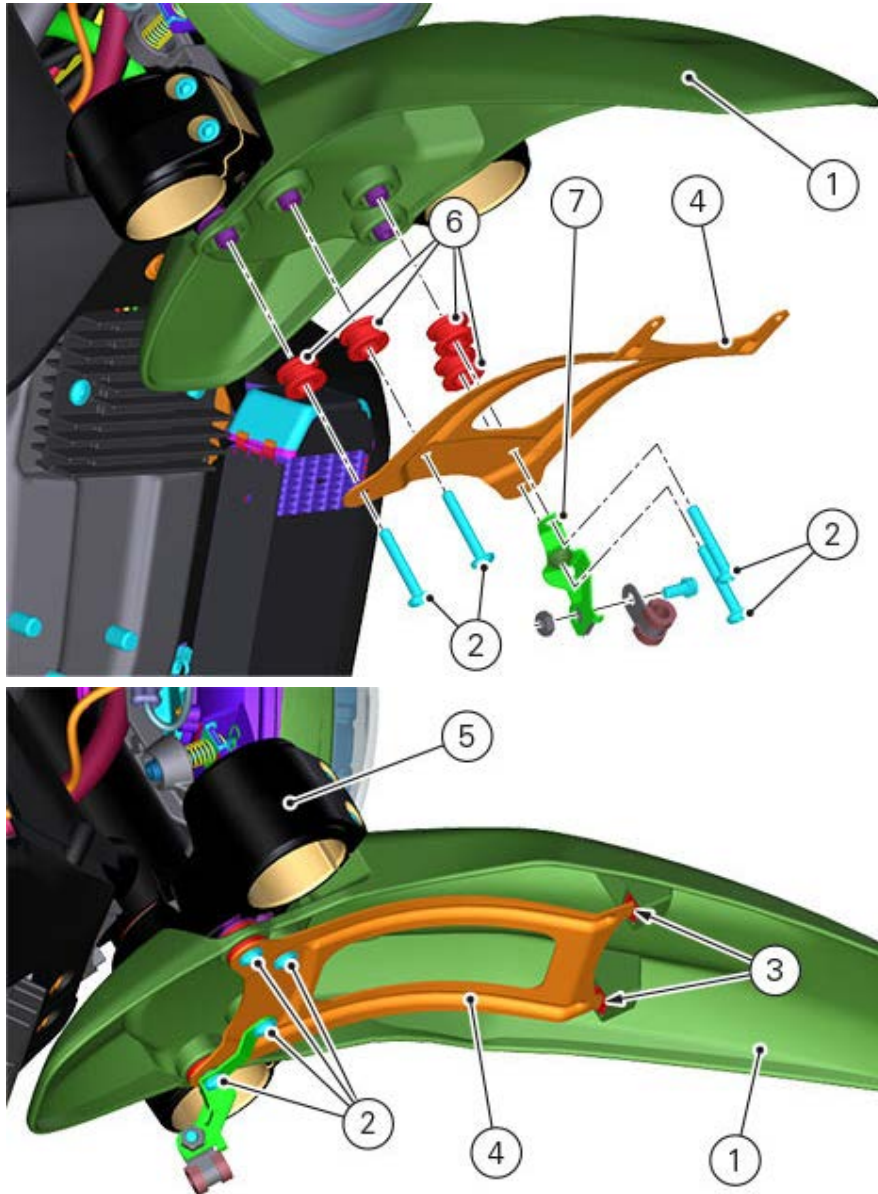

Removing the front mudguard

Loosen the four screws (2) from the lower side of the front mudguard (1).
Remove the front mudguard (1).

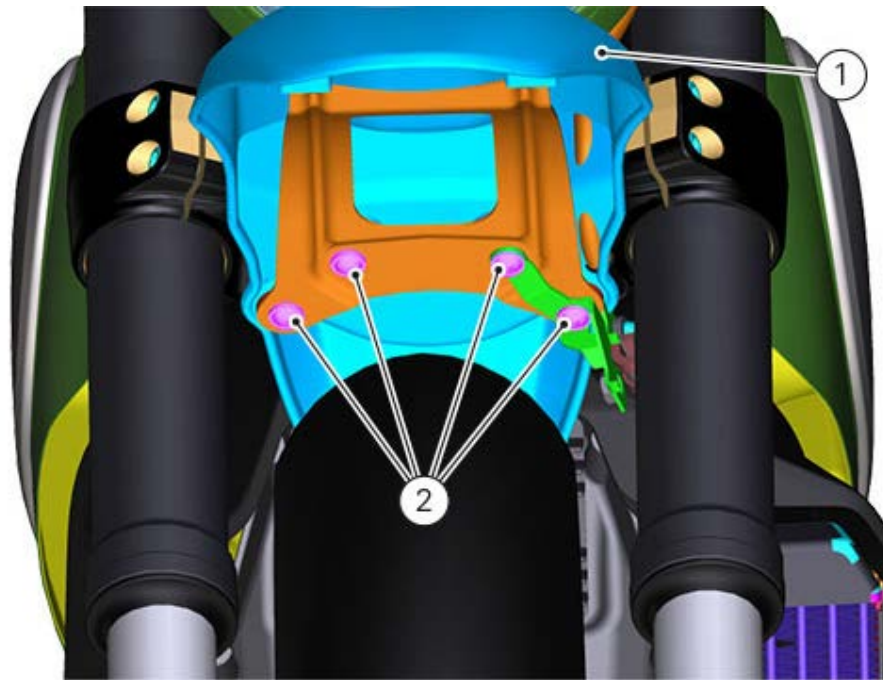

Refitting the front mudguard

Position the front mudguard by centring it on the forks.
Start four screws (2) with spacer (3) on front mudguard (1).

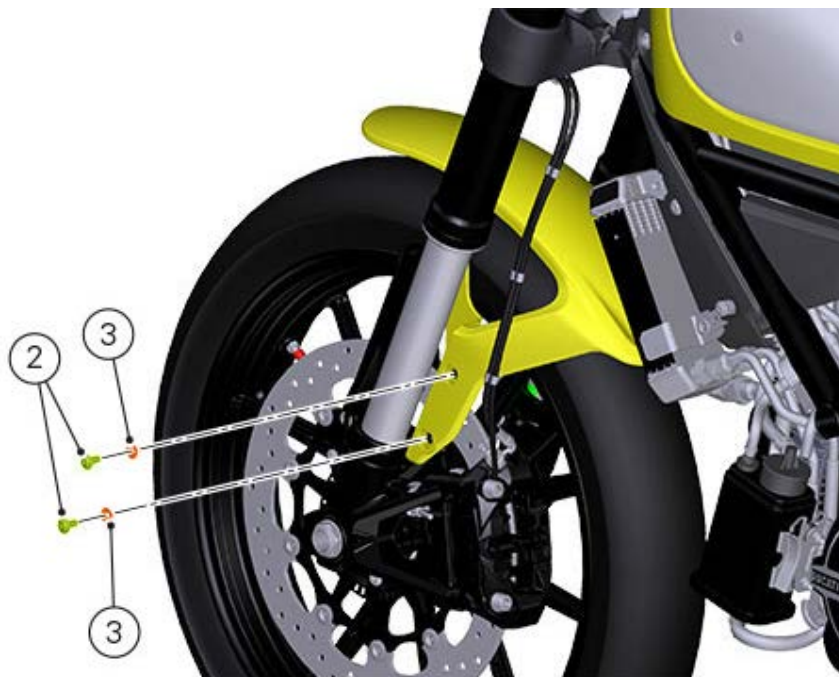

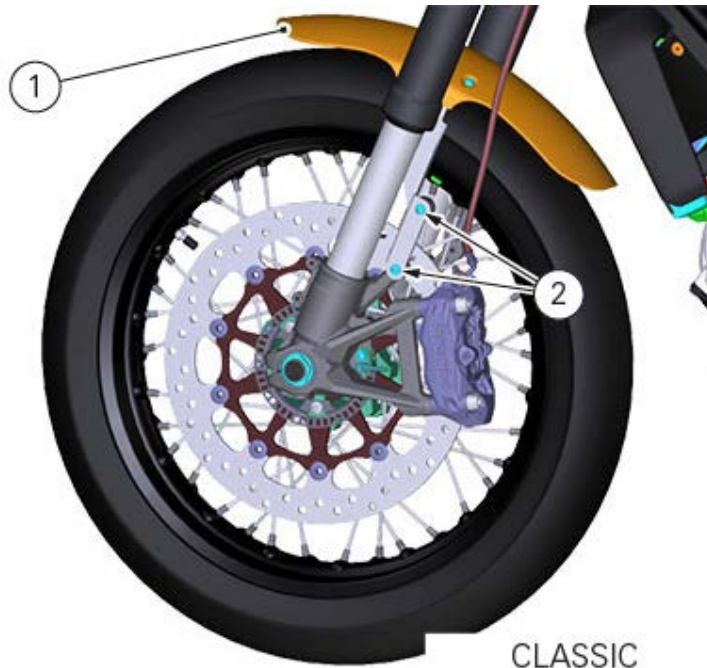

CLASSIC

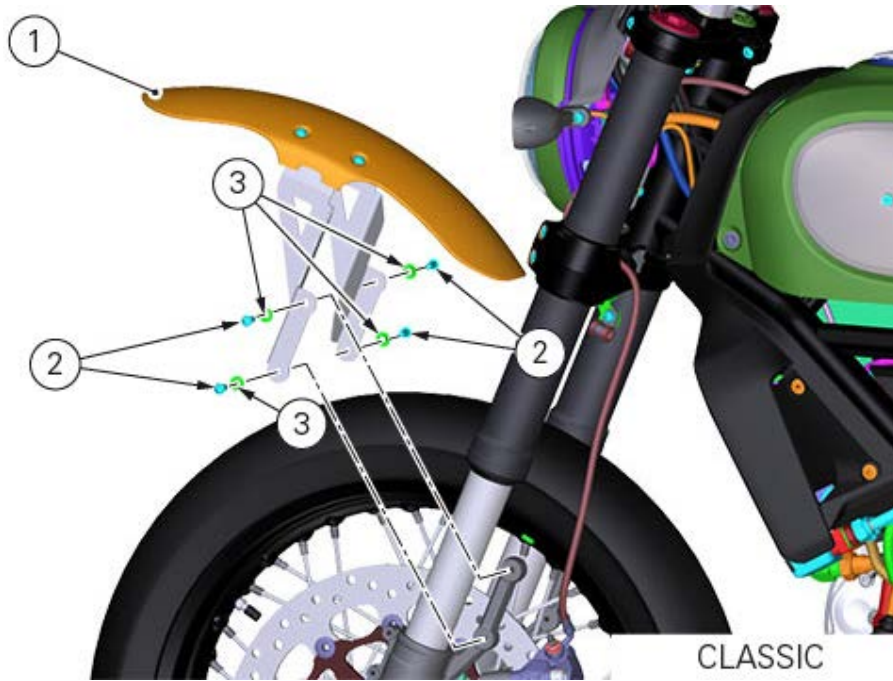

CLASSIC

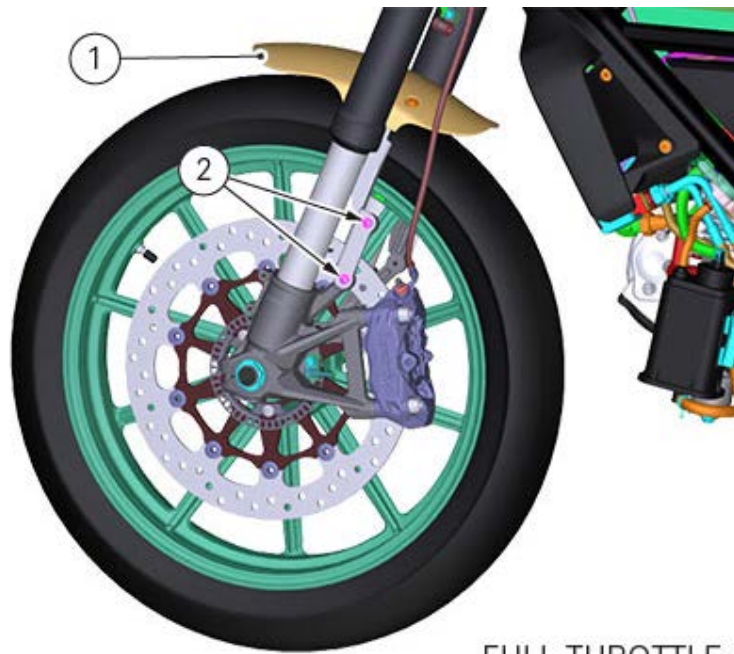

FULL THROTTLE

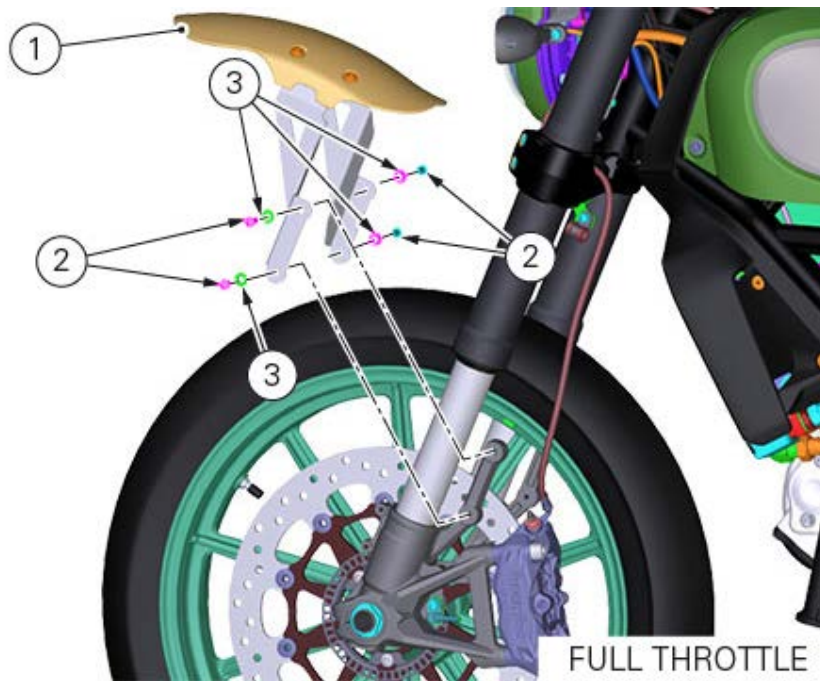

FULL THROTTLE

Tighten the four screws (2) to a torque of $8 \text{ Nm} \pm 10\%$.

Removing the front mudguard

Loosen the two screws (2) from both sides of the front mudguard (1).
Remove the front mudguard (1).

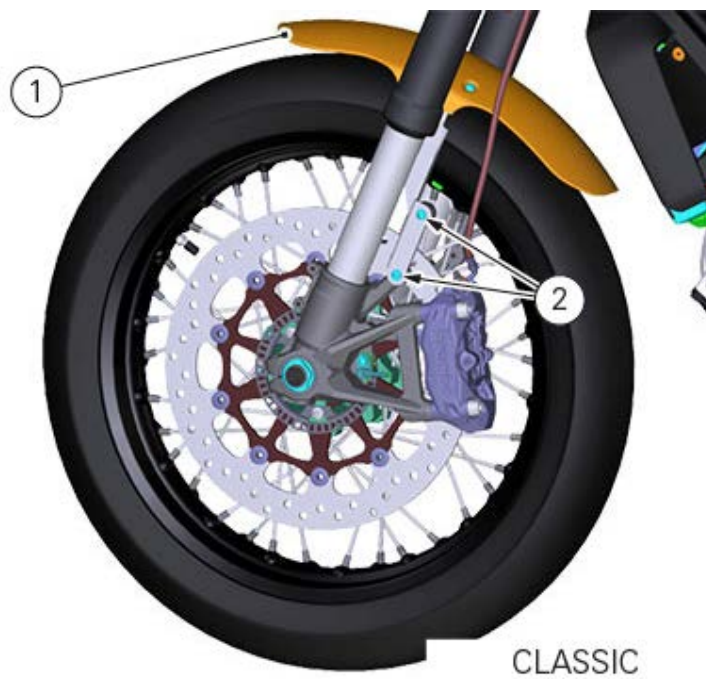

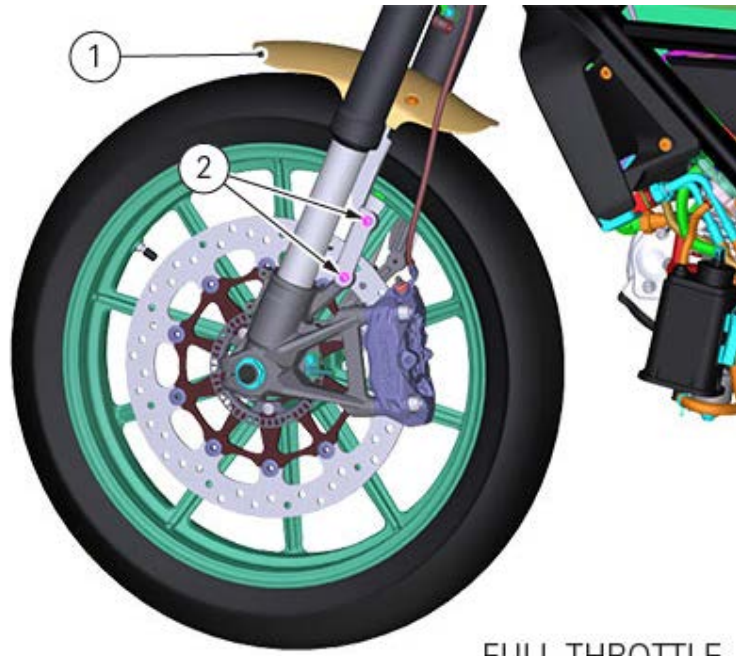

FULL THROTTLE

Refitting the belly pan

On the vehicle left side, if previously removed, install bracket (3) by tightening screw (5) with spacer (4). Make sure clip (6) is in place.

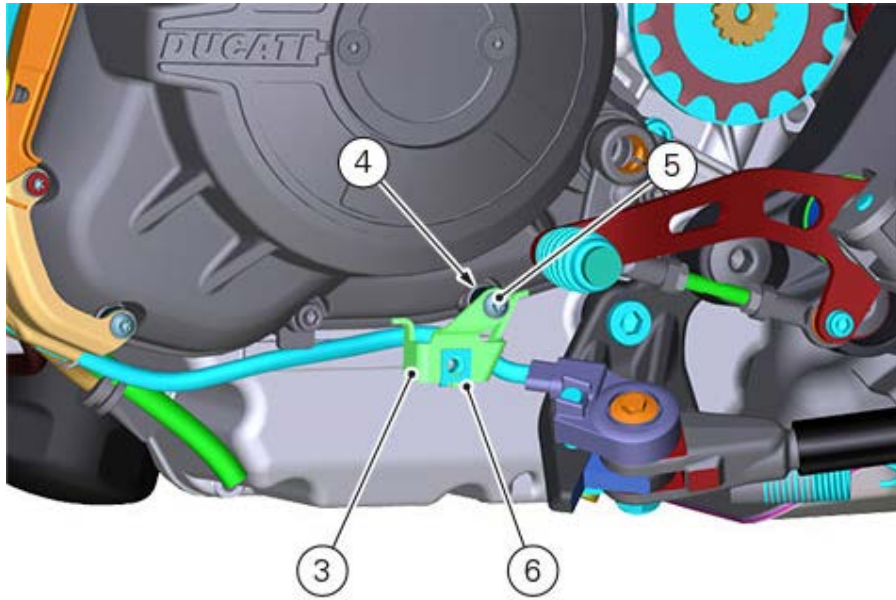

If previously removed, install bracket (7) and fix it by means of screws (8) with spacers (9).

USA version

Besides the support (7), fix also the Canister support (12). Fix it by means of screws (14) with spacer (13) and screw (8) with spacer (9).

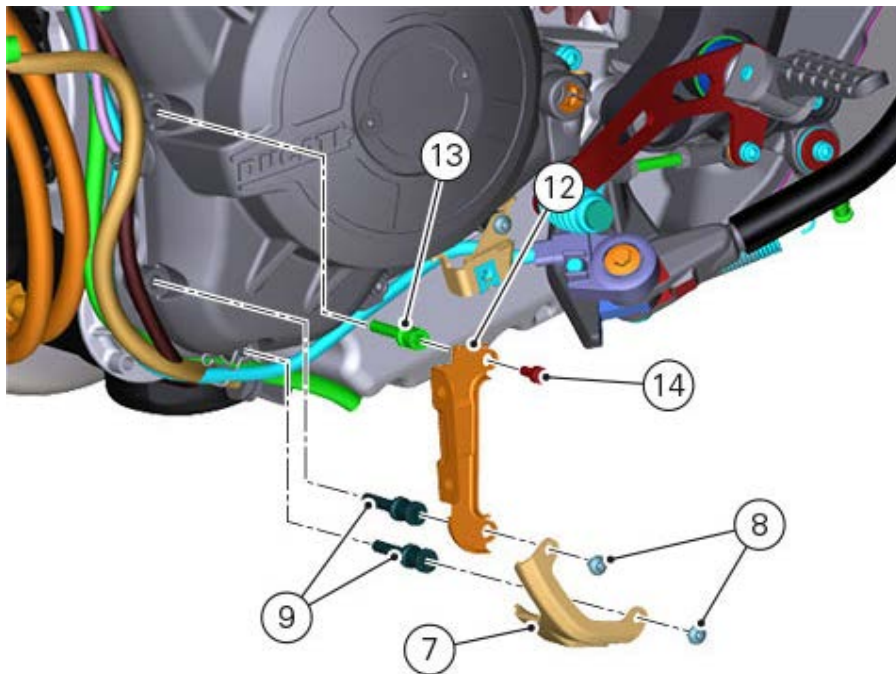

Make sure clip (15) is in place.

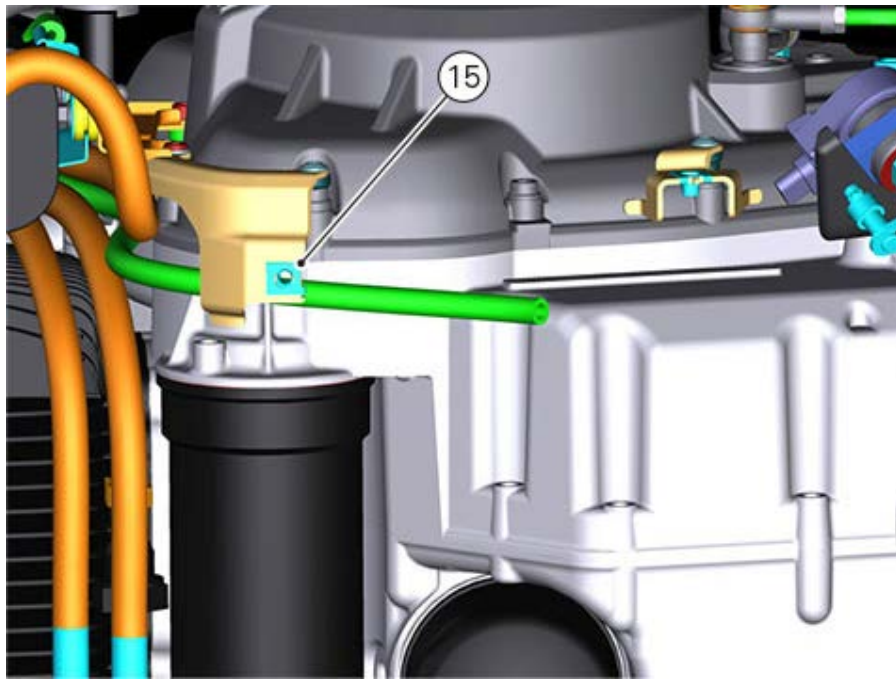

On the vehicle right side, if previously removed, install mounting bracket (19) by means of screw (16) with spacer (17).

Make sure clip (18) is in place.

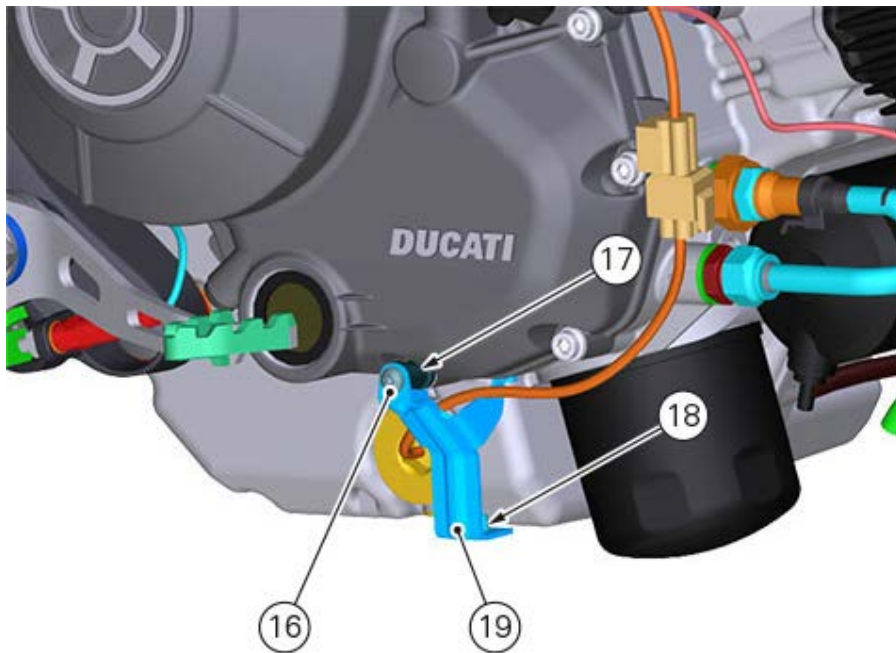

Check that rubber elements (20) and spacers (21) are fitted on the sump guard.

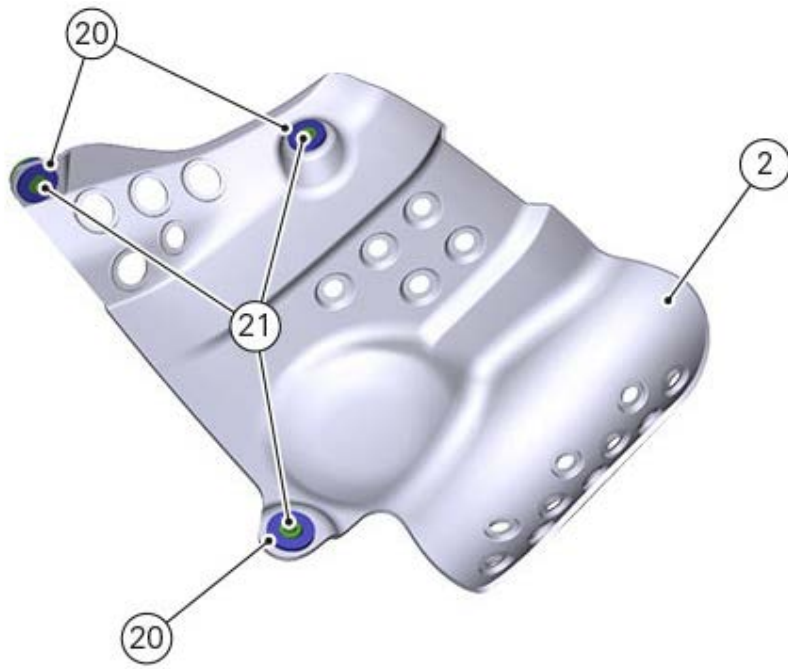

Fix heat guard (2) by tightening screws (1).

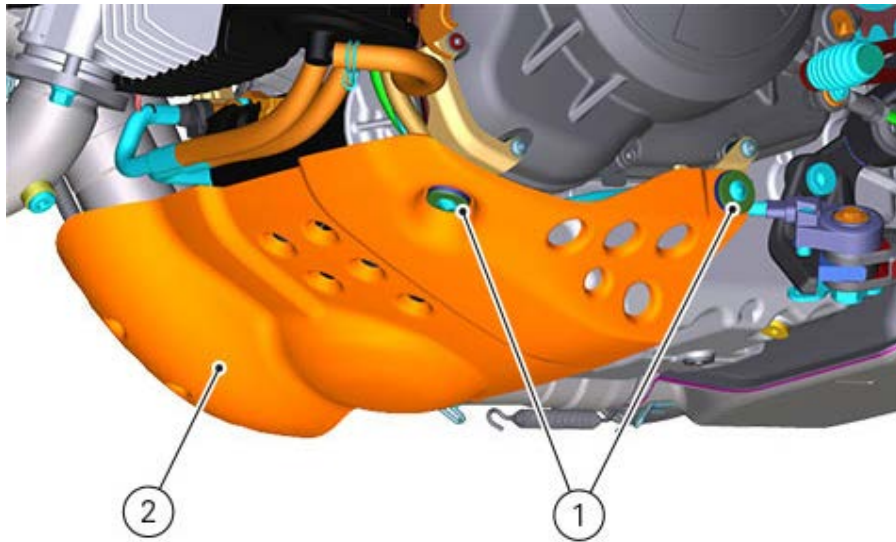

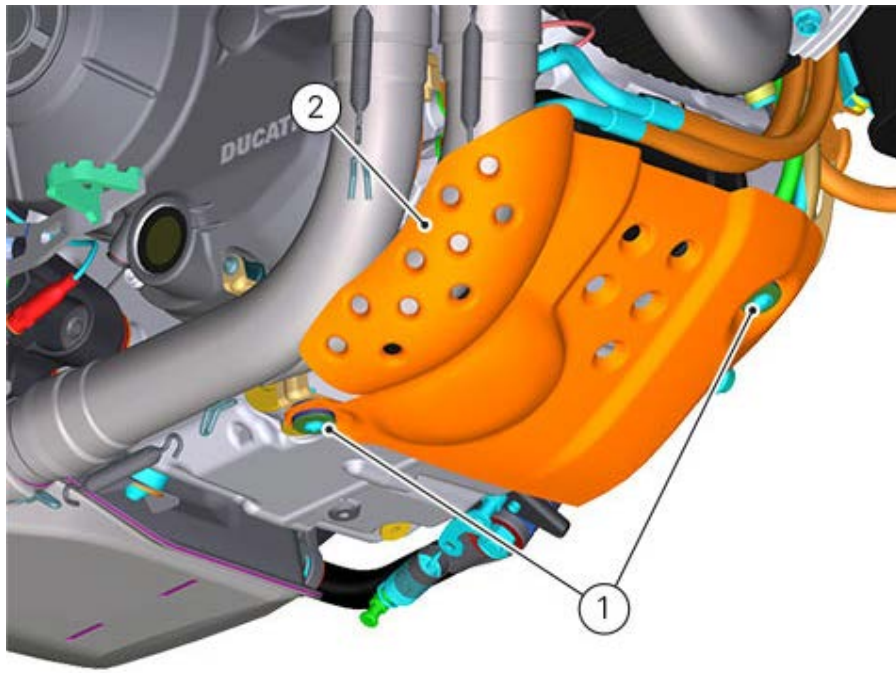

Removing the belly pan

Undo screws (1) that retain the belly pan (2).
Remove the belly pan (2).

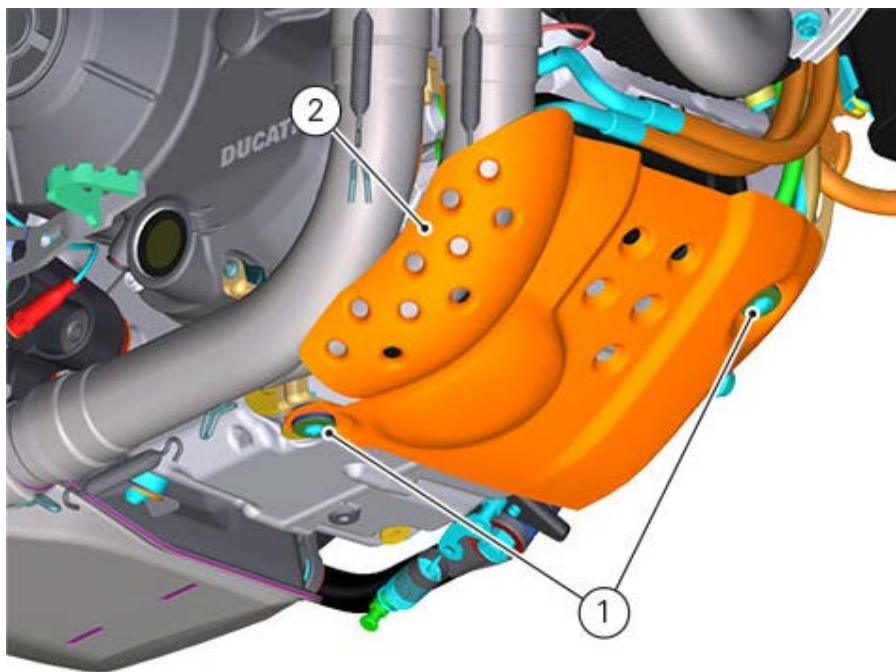
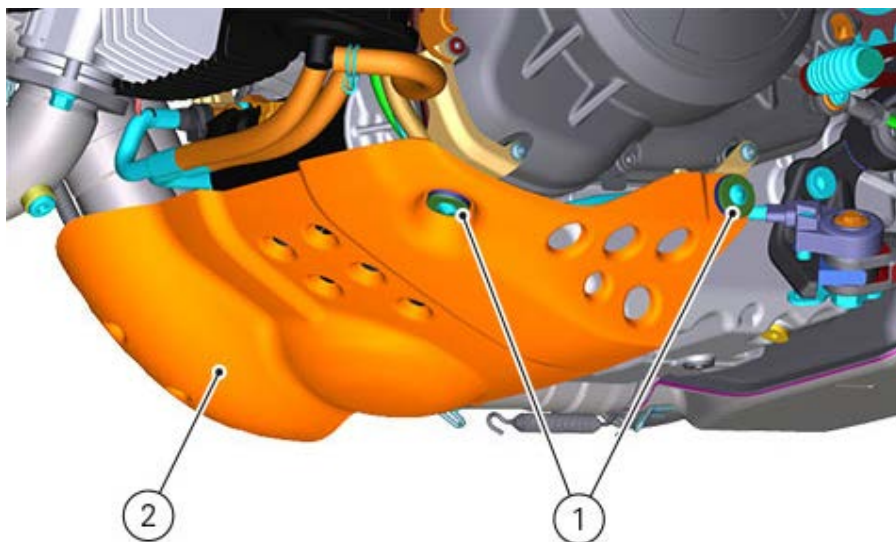
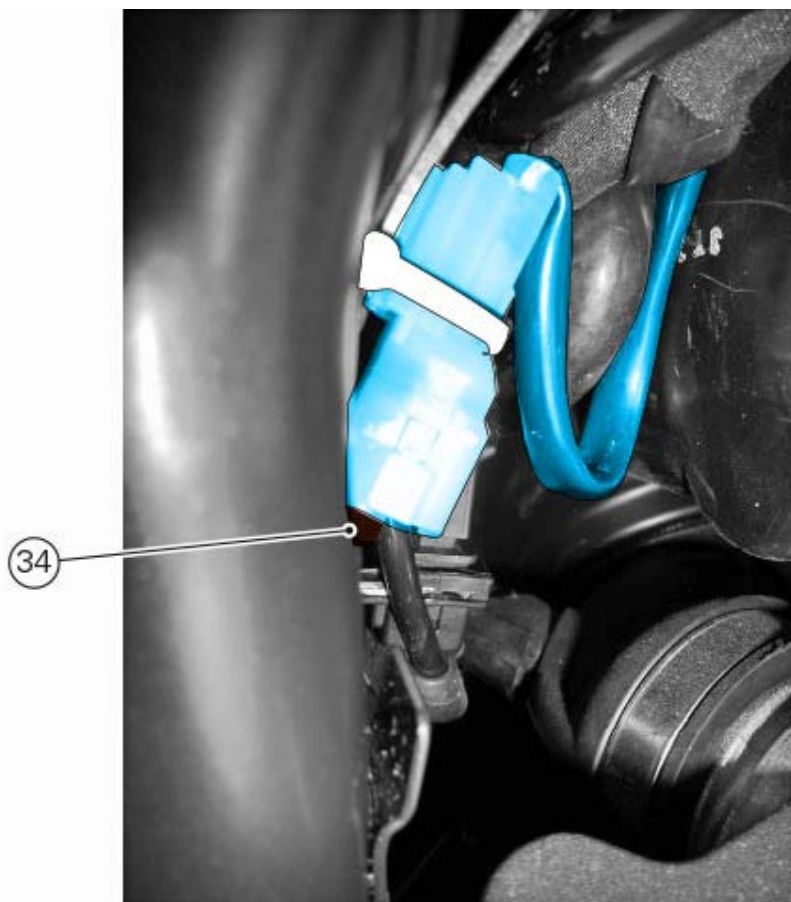
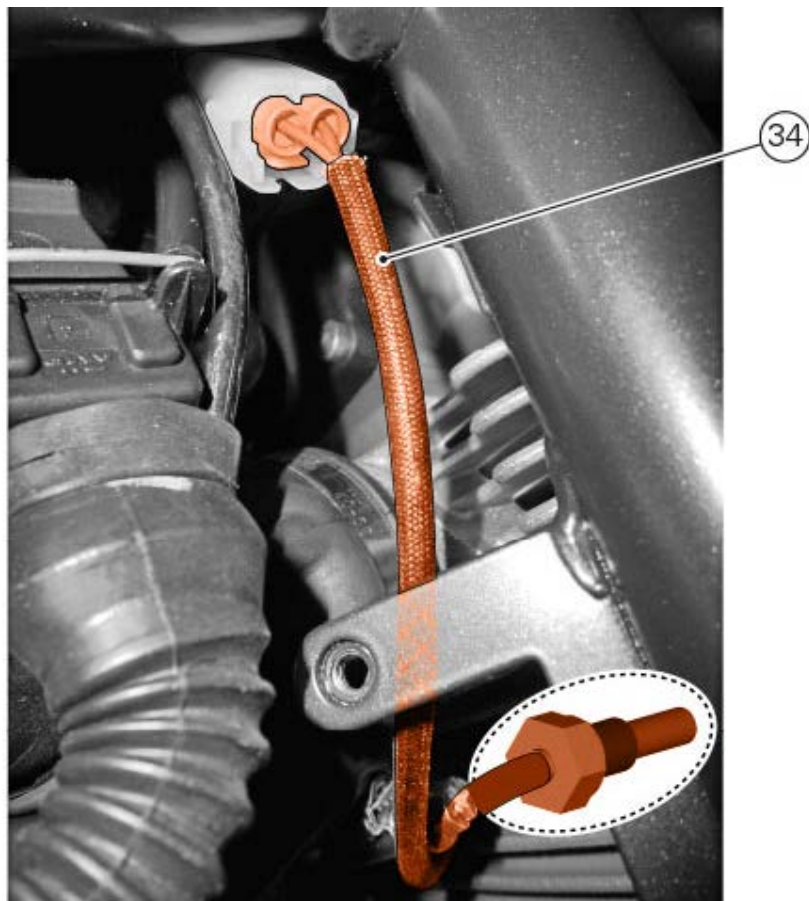
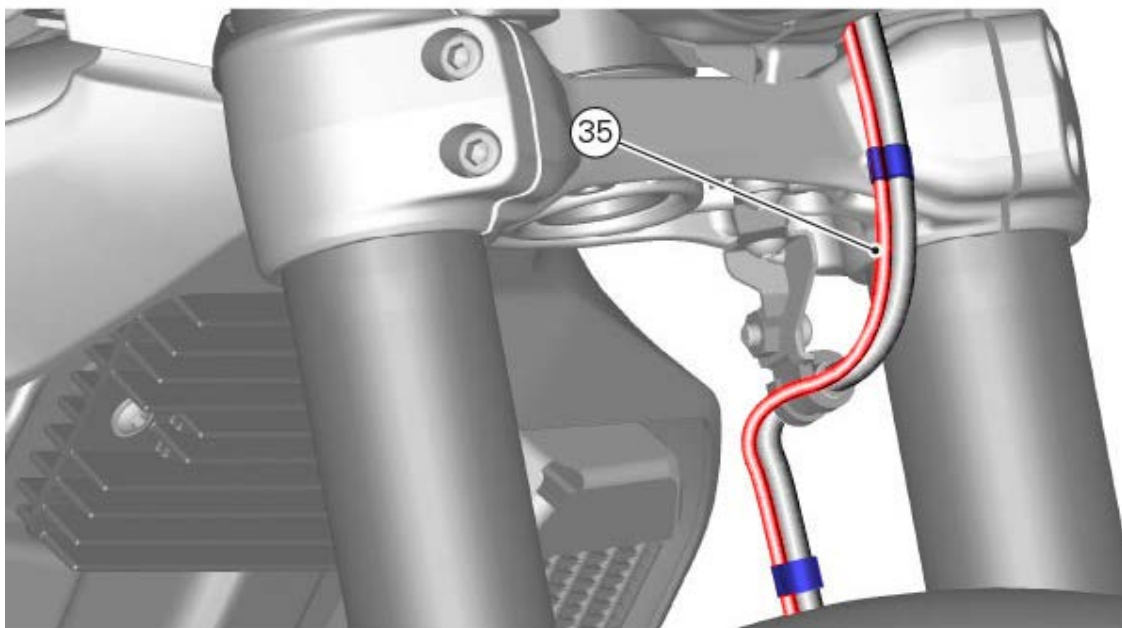
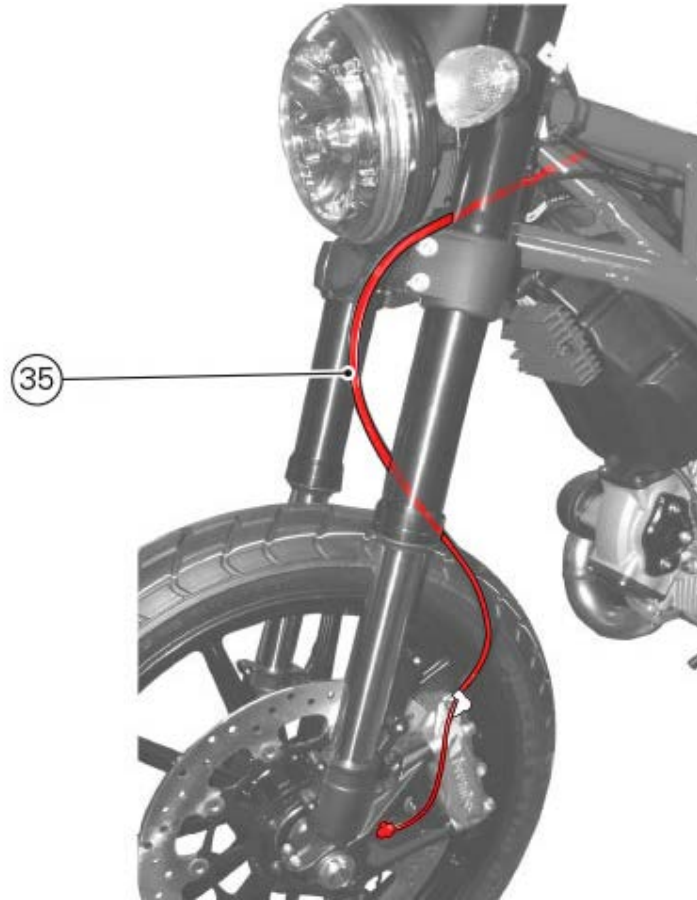

Table Z



For the complete index of the wirings, divided by tables, refer to chapter "Routing of wiring on frame".

TABLE AA



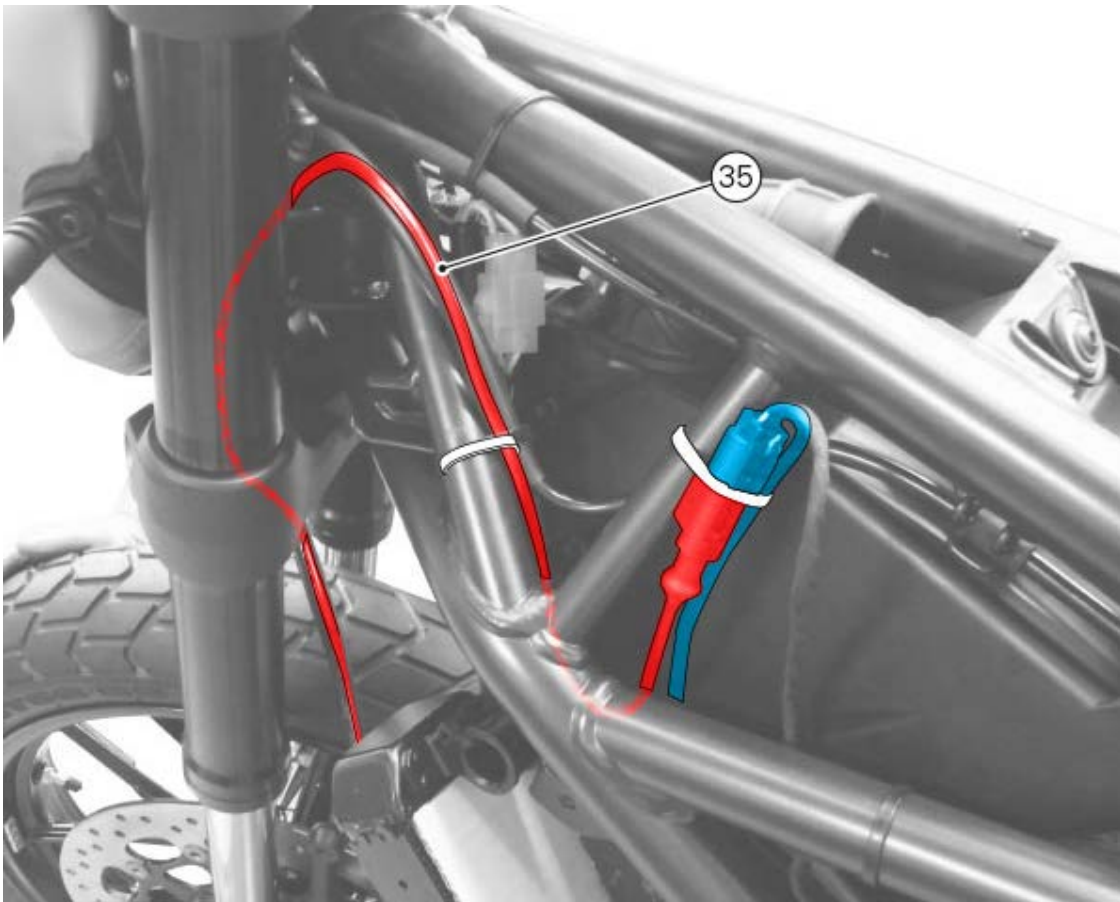

For the complete index of the wirings, divided by tables, refer to chapter "[Routing of wiring on frame](#)".

TABLE BB

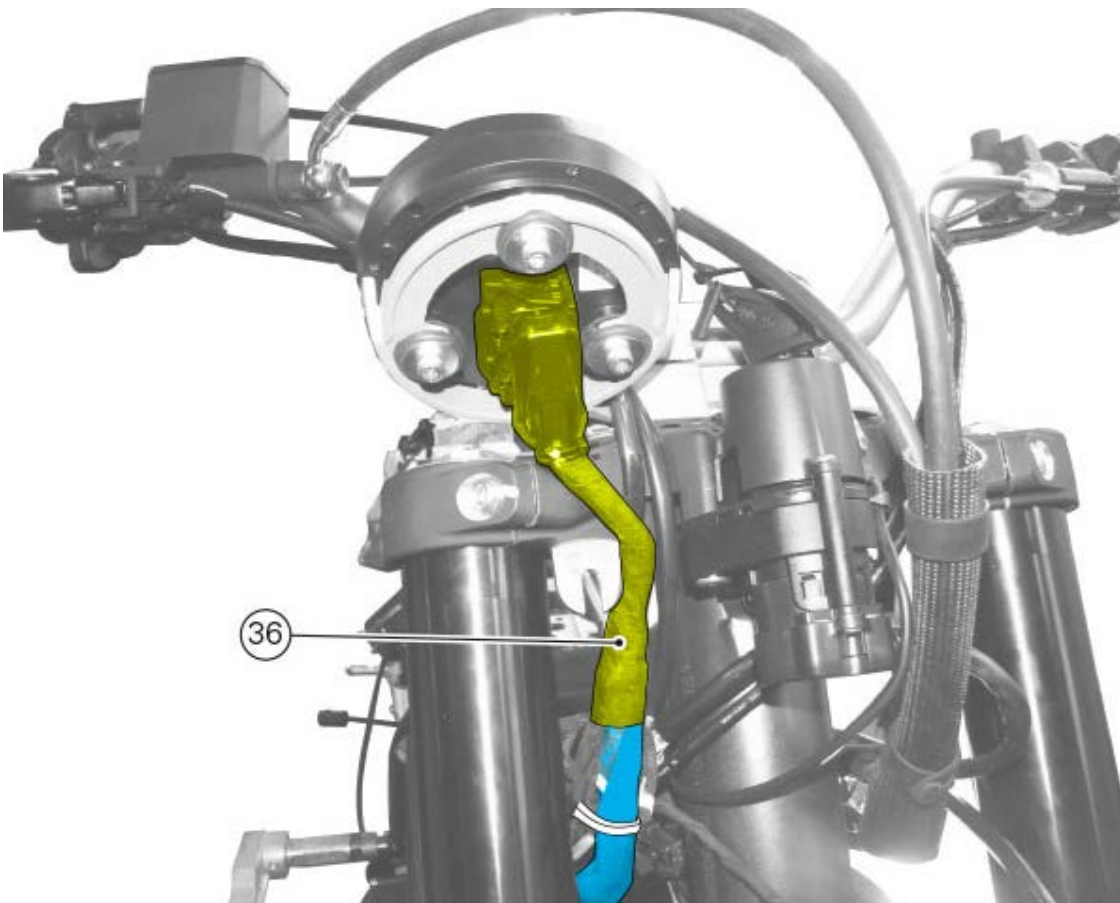

For the complete index of the wirings, divided by tables, refer to chapter "Routing of wiring on frame".

TABLE CC

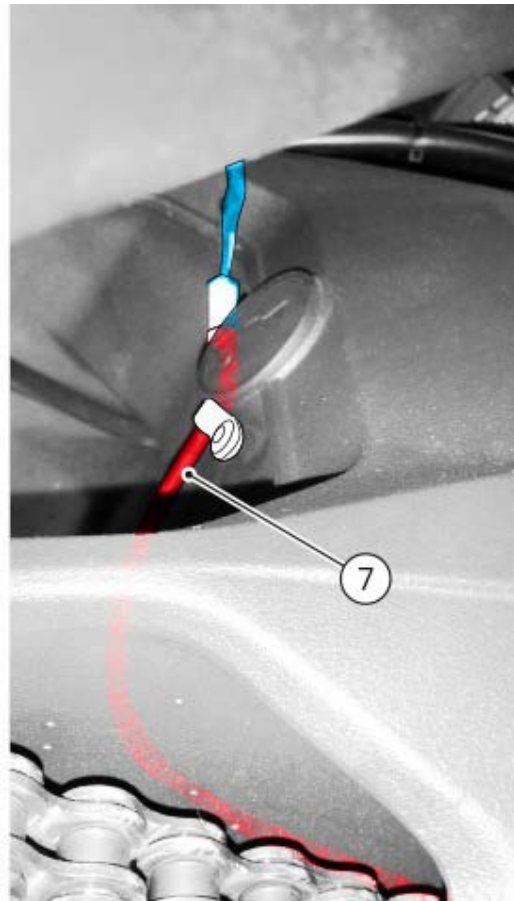
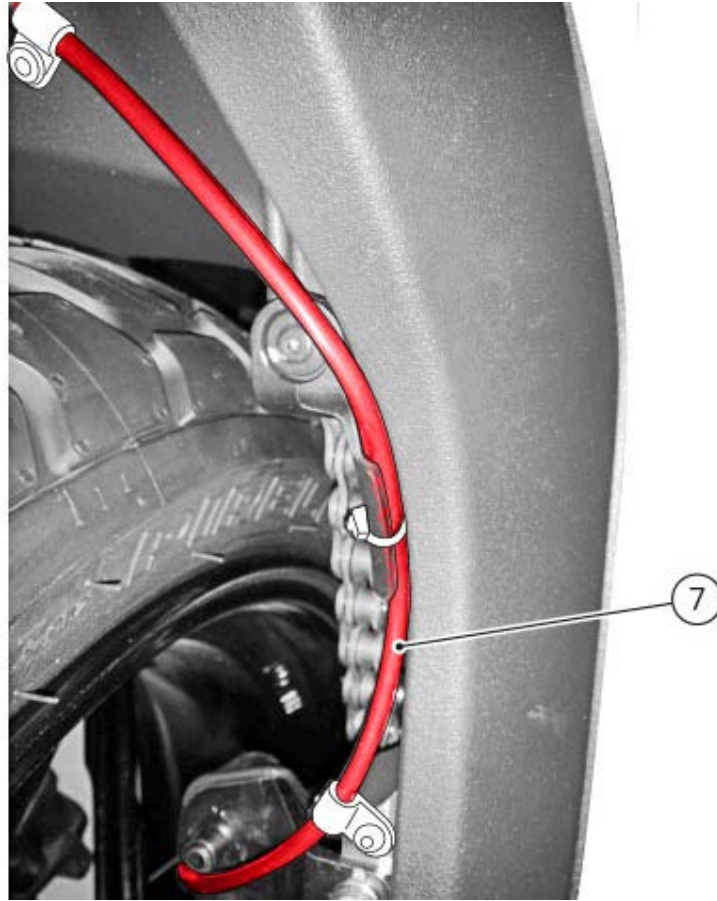



For the complete index of the wirings, divided by tables, refer to chapter "[Routing of wiring on frame](#)".

TABLE DD

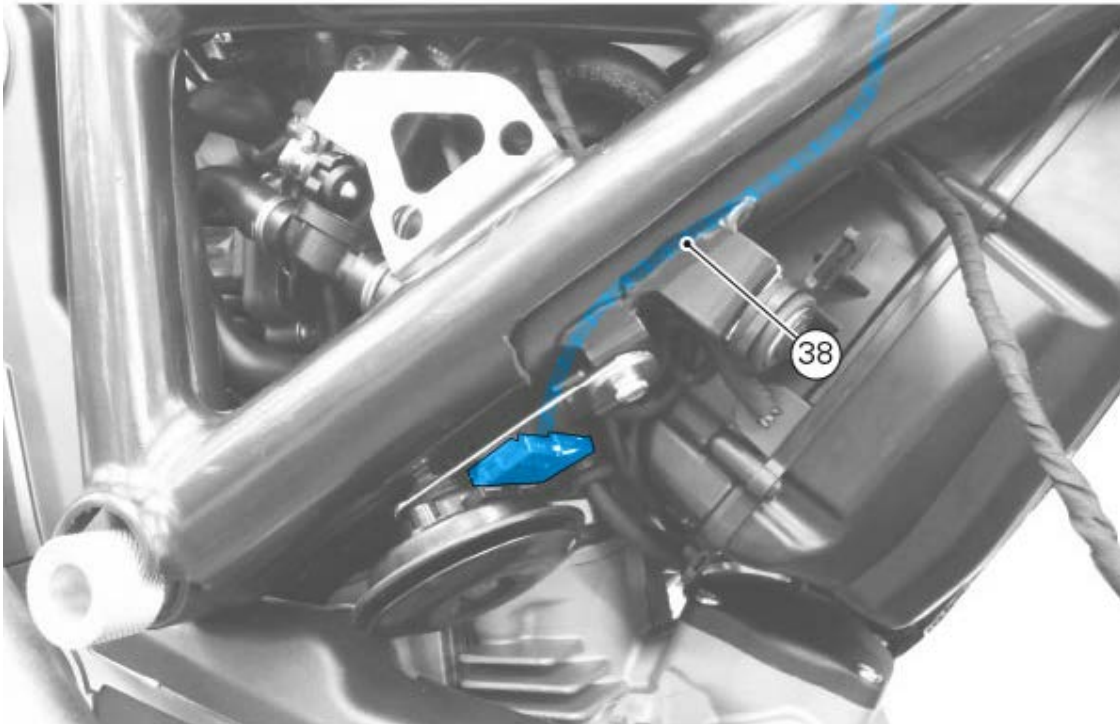

For the complete index of the wirings, divided by tables, refer to chapter "[Routing of wiring on frame](#)".

Table Y

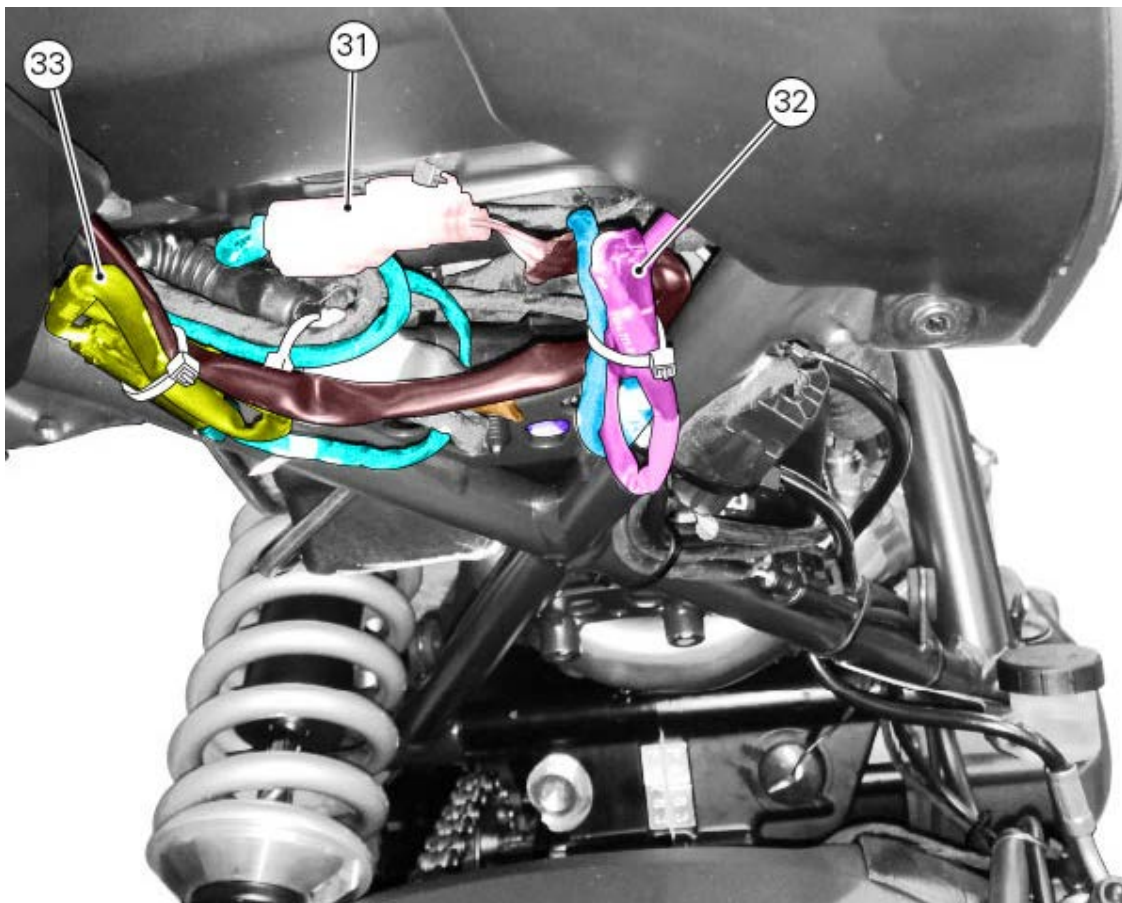

For the complete index of the wirings, divided by tables, refer to chapter "[Routing of wiring on frame](#)".

Table X

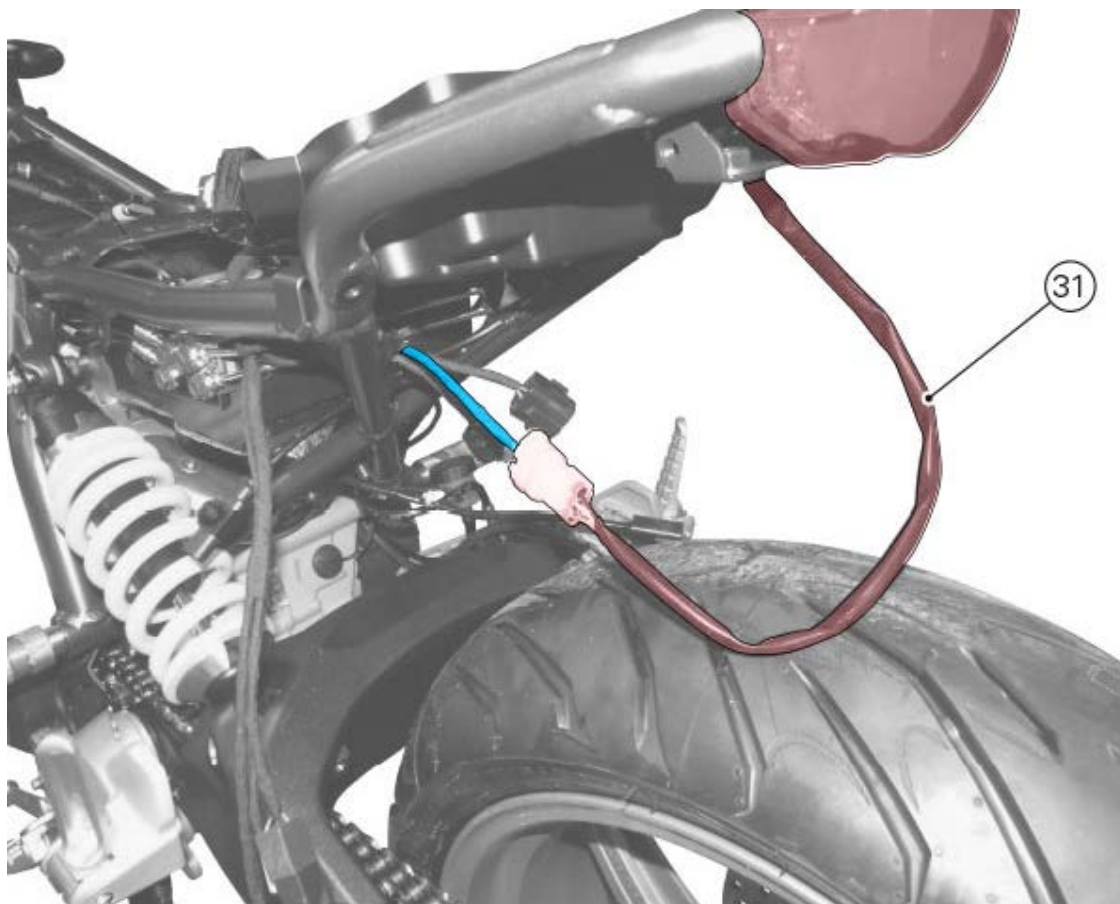
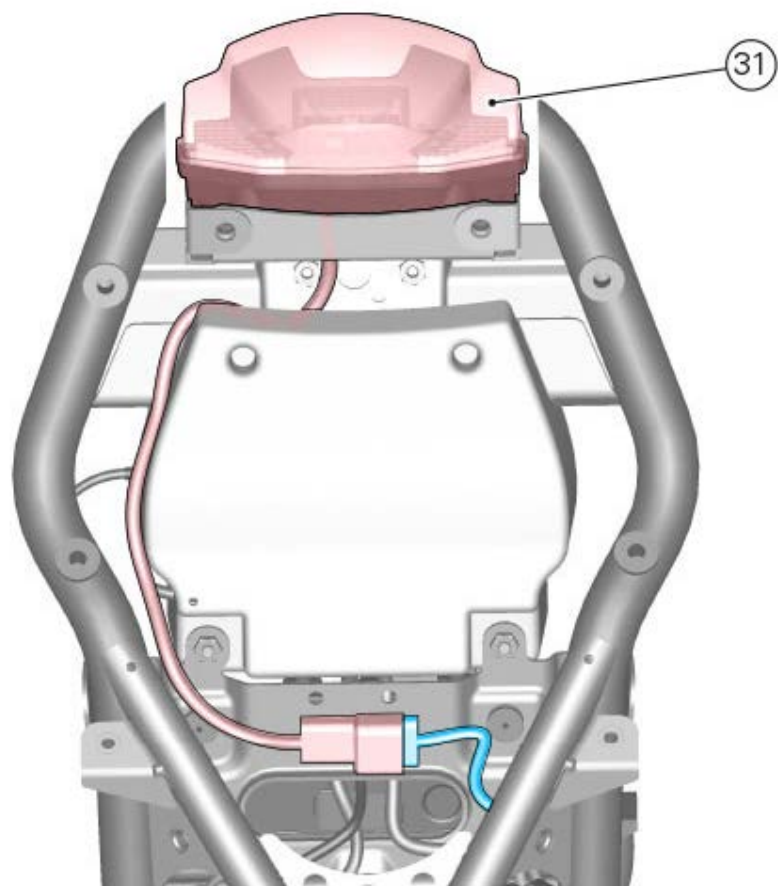

For the complete index of the wirings, divided by tables, refer to chapter "Routing of wiring on frame".

Table W

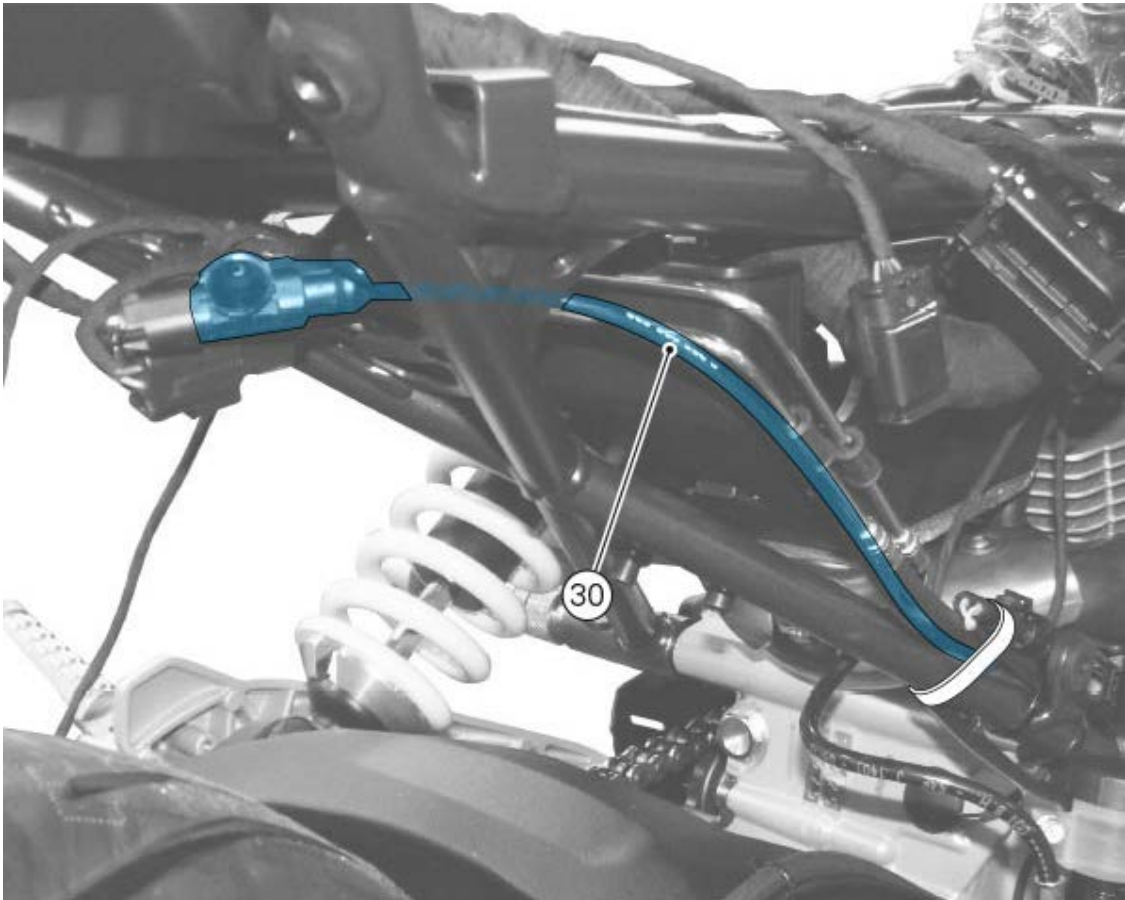
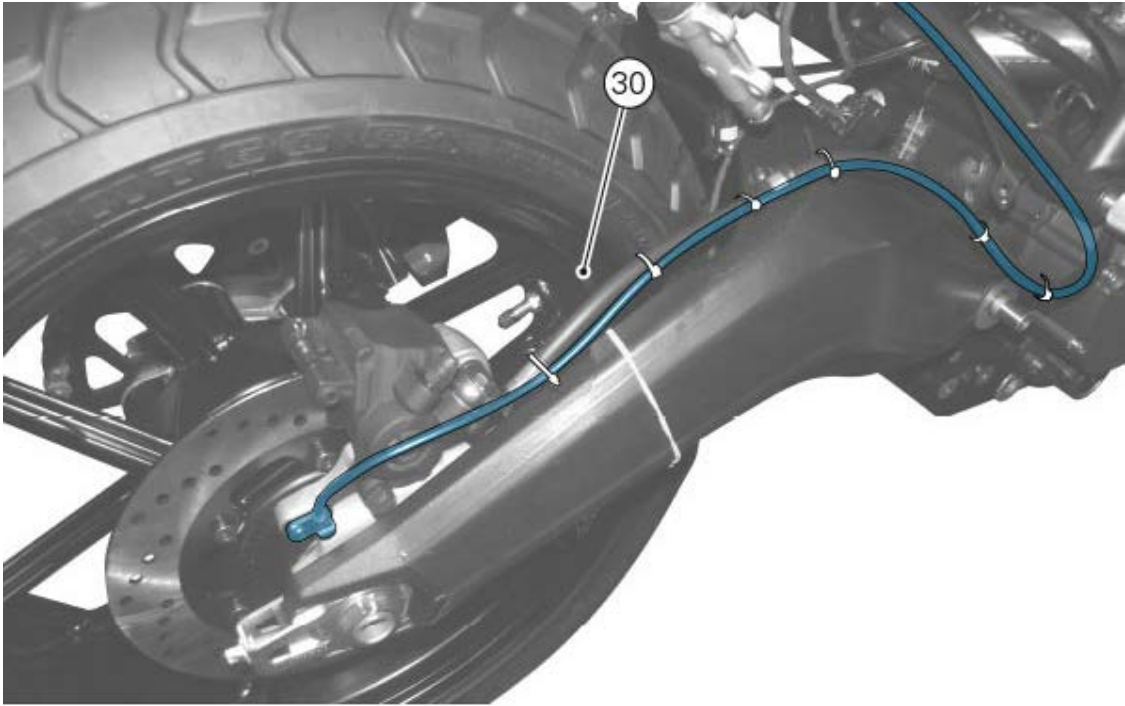

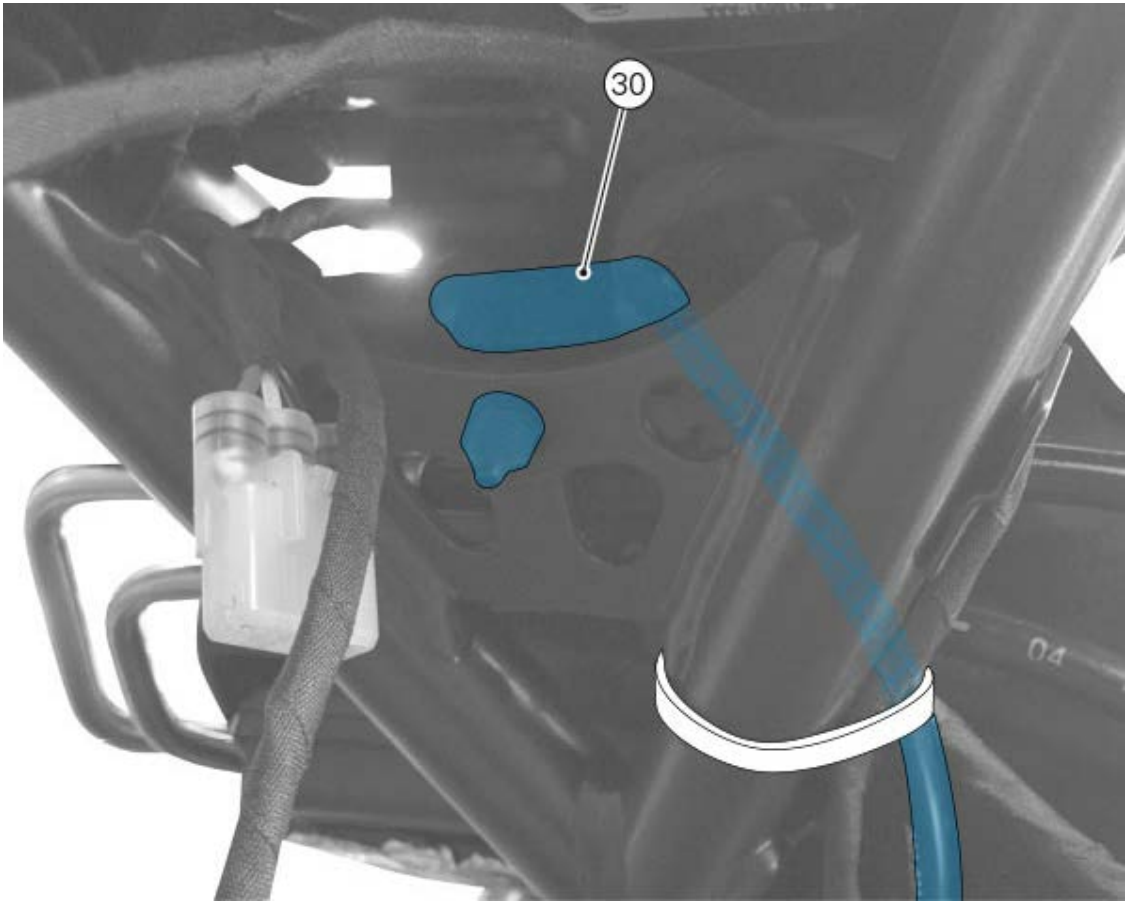

For the complete index of the wirings, divided by tables, refer to chapter "[Routing of wiring on frame](#)".

Table V



For the complete index of the wirings, divided by tables, refer to chapter "[Routing of wiring on frame](#)".

Table U

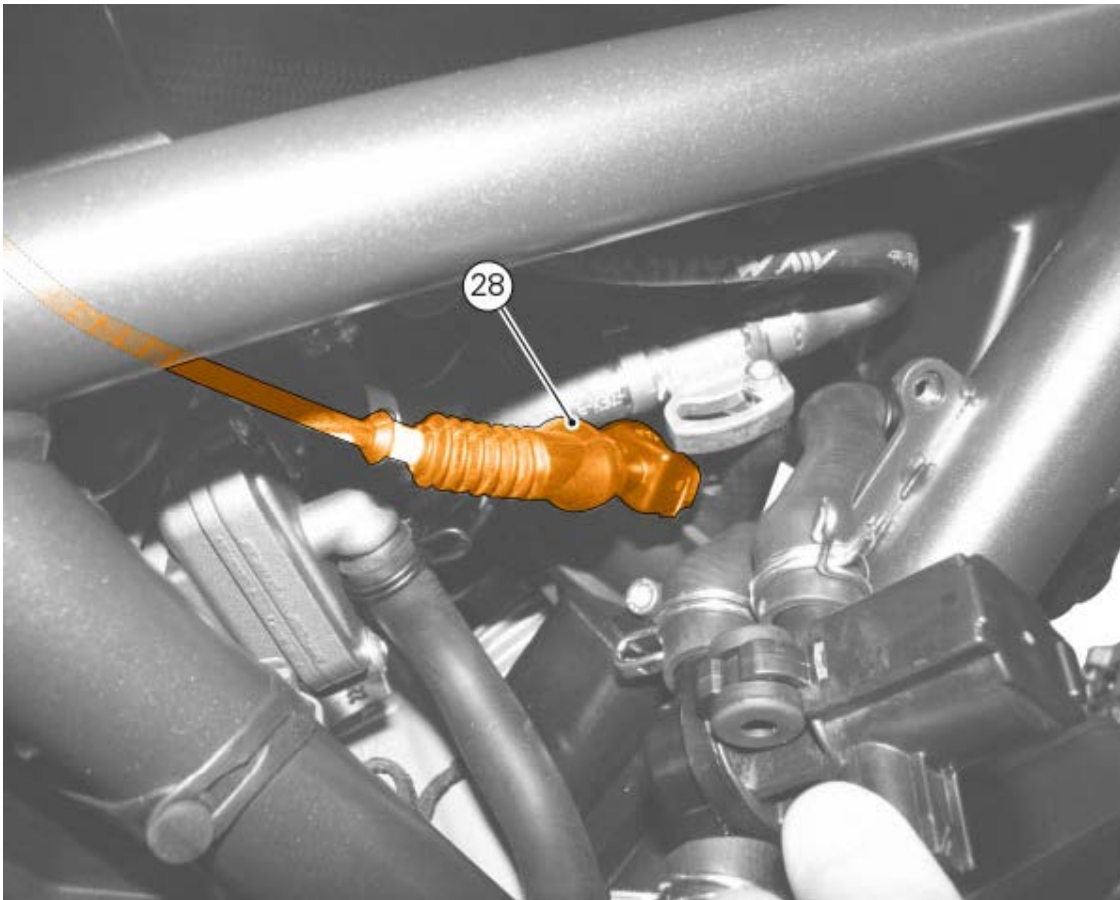

For the complete index of the wirings, divided by tables, refer to chapter "[Routing of wiring on frame](#)".

Table T

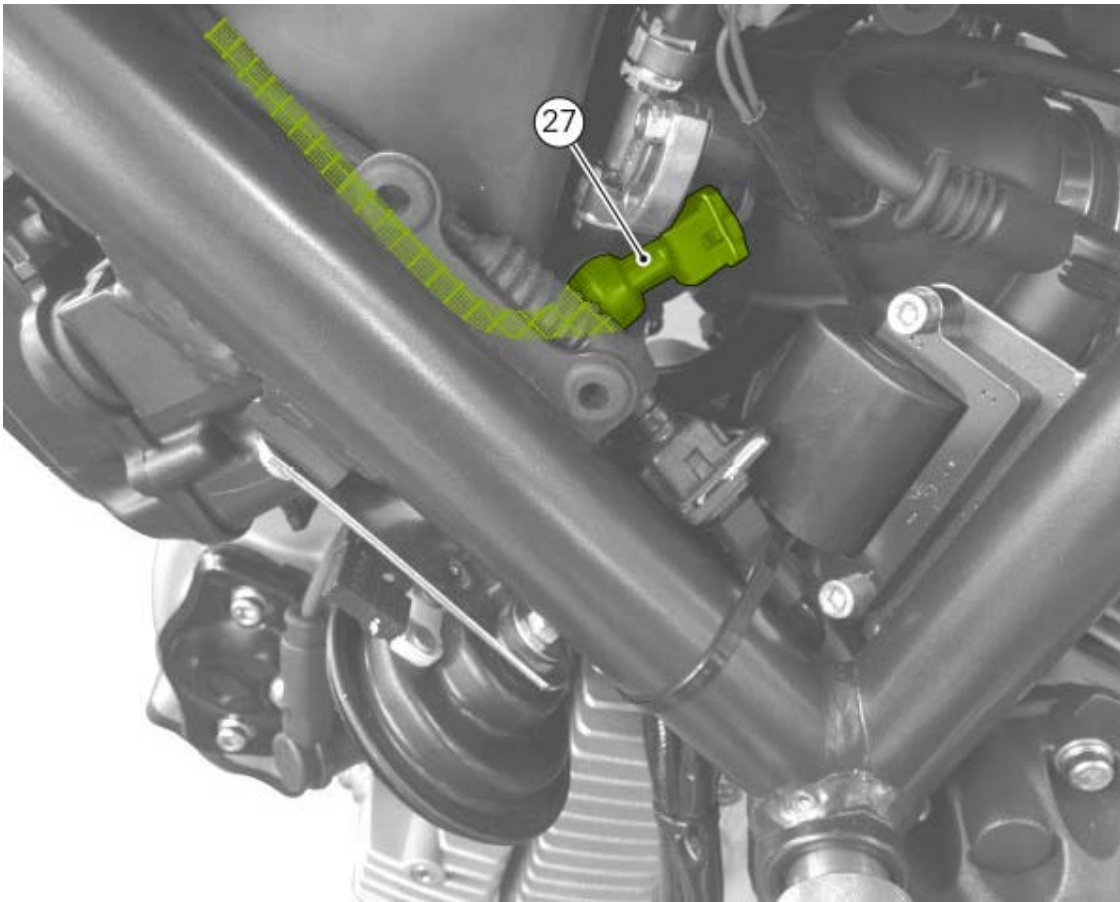

For the complete index of the wirings, divided by tables, refer to chapter "[Routing of wiring on frame](#)".

Table S

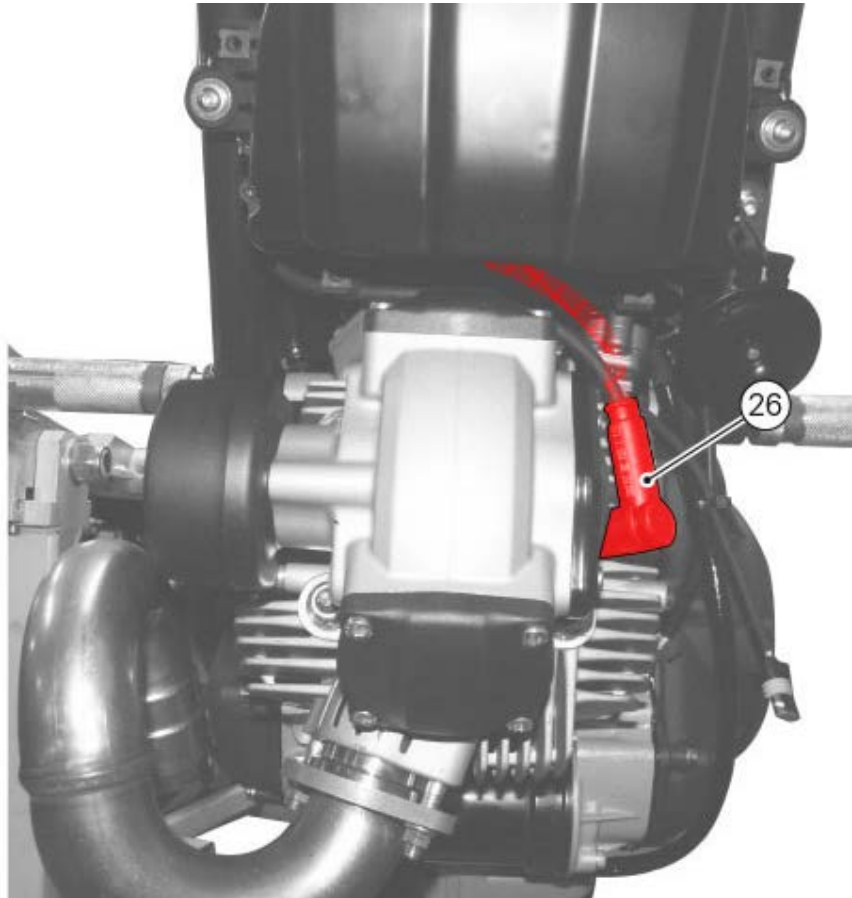
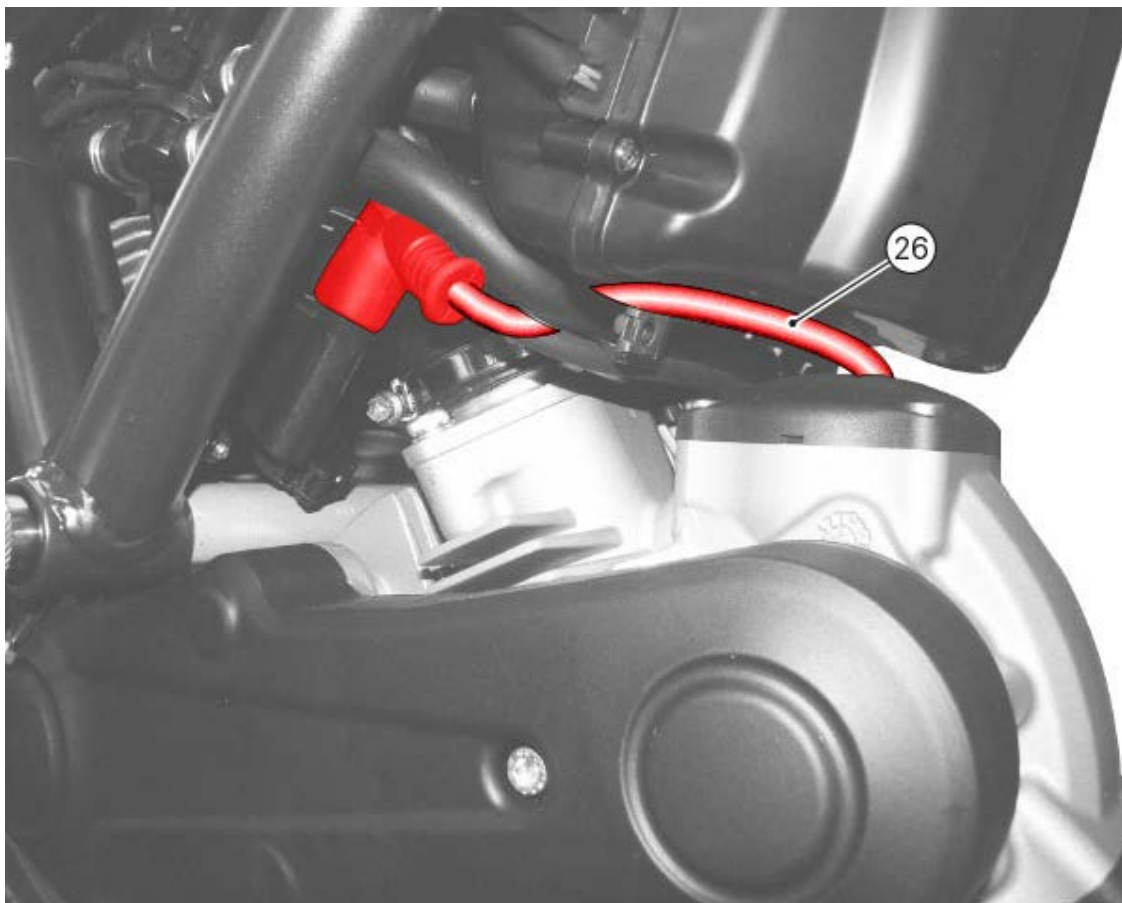

For the complete index of the wirings, divided by tables, refer to chapter "[Routing of wiring on frame](#)".

Table R

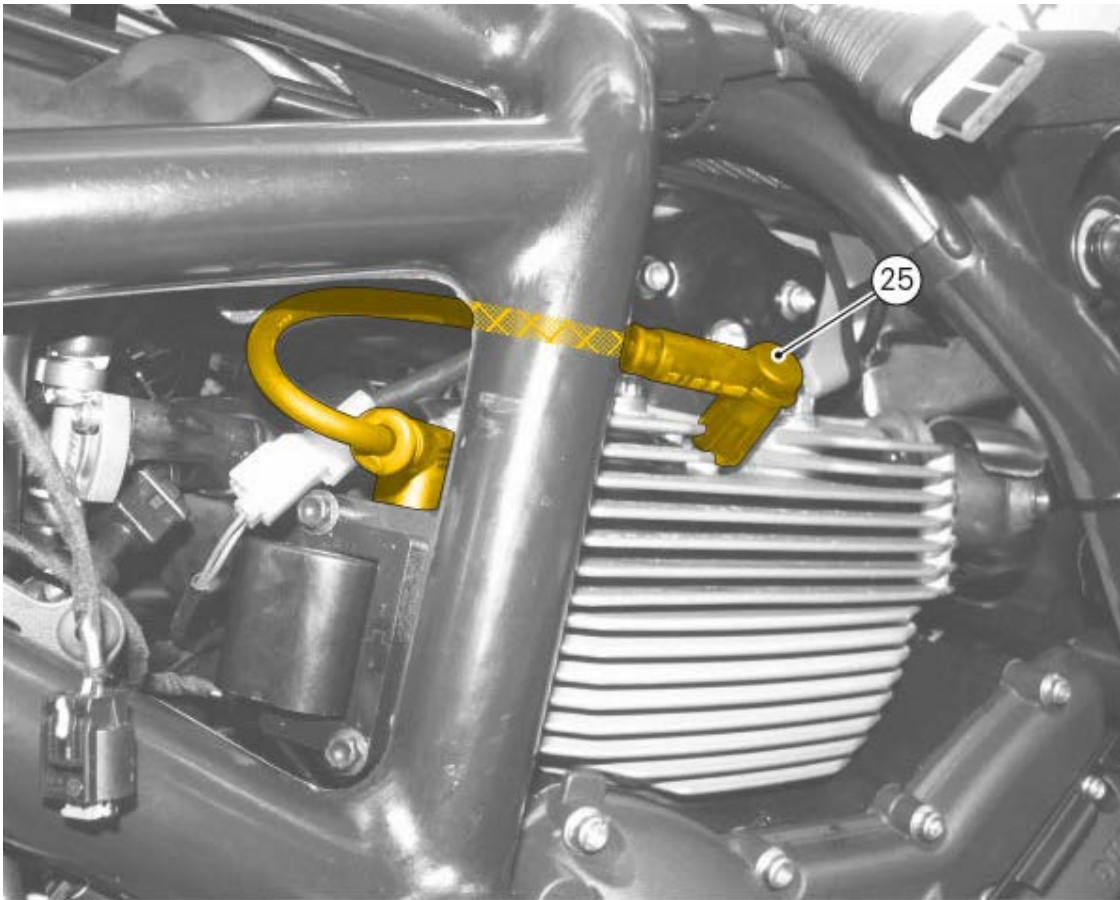

For the complete index of the wirings, divided by tables, refer to chapter "[Routing of wiring on frame](#)".

Table Q



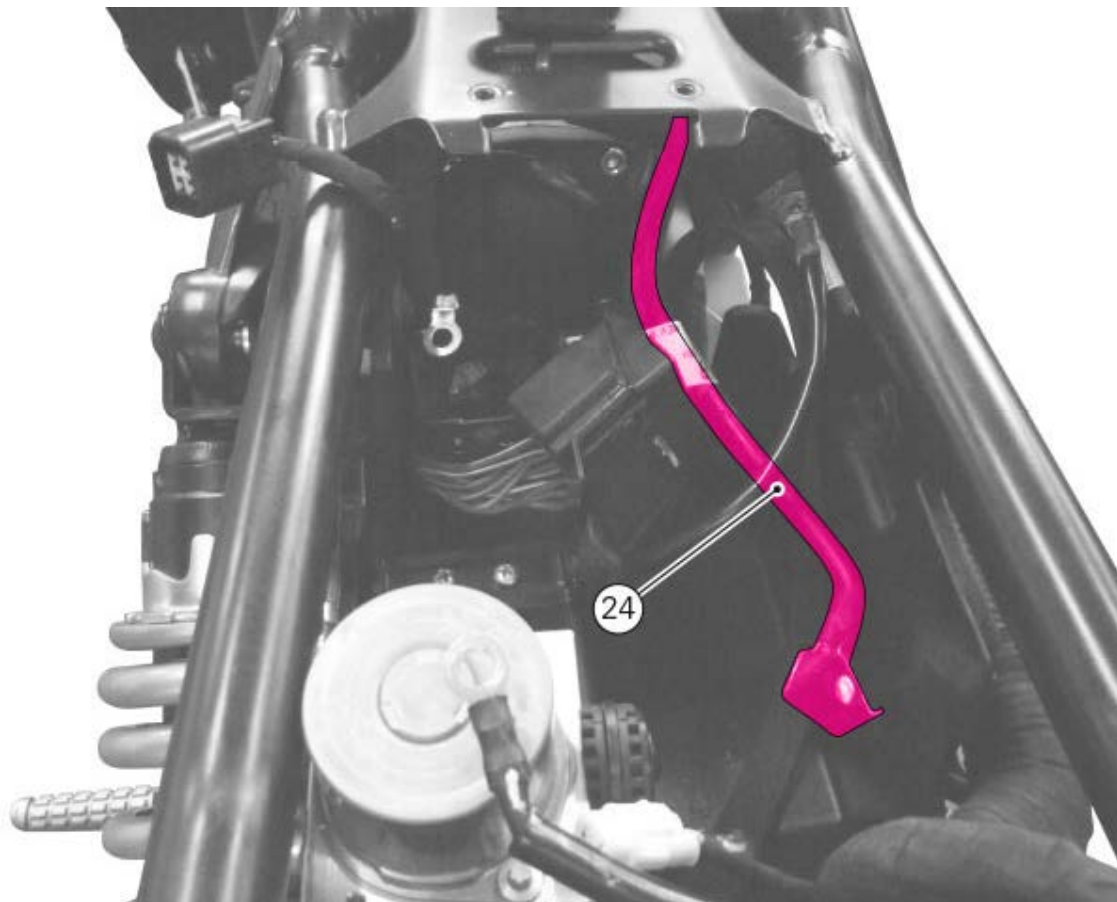

For the complete index of the wirings, divided by tables, refer to chapter "[Routing of wiring on frame](#)".

Table P

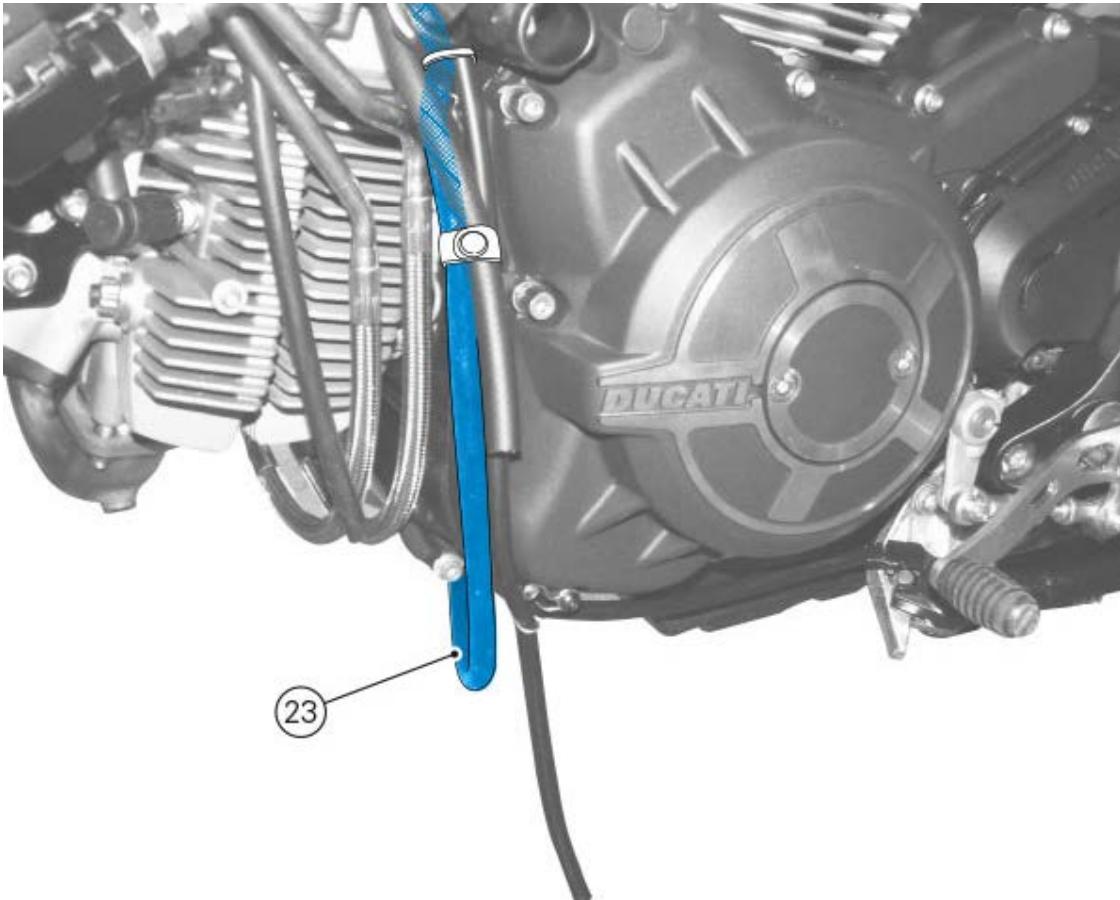
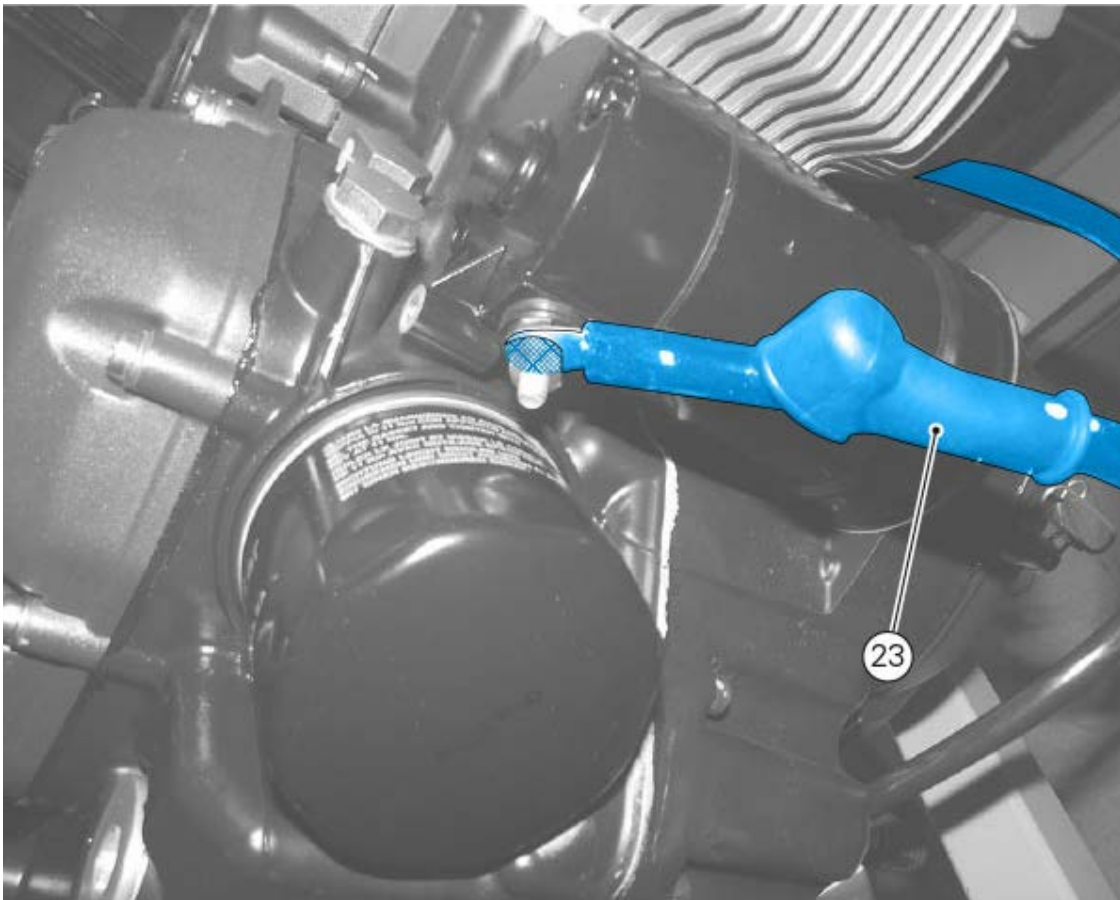

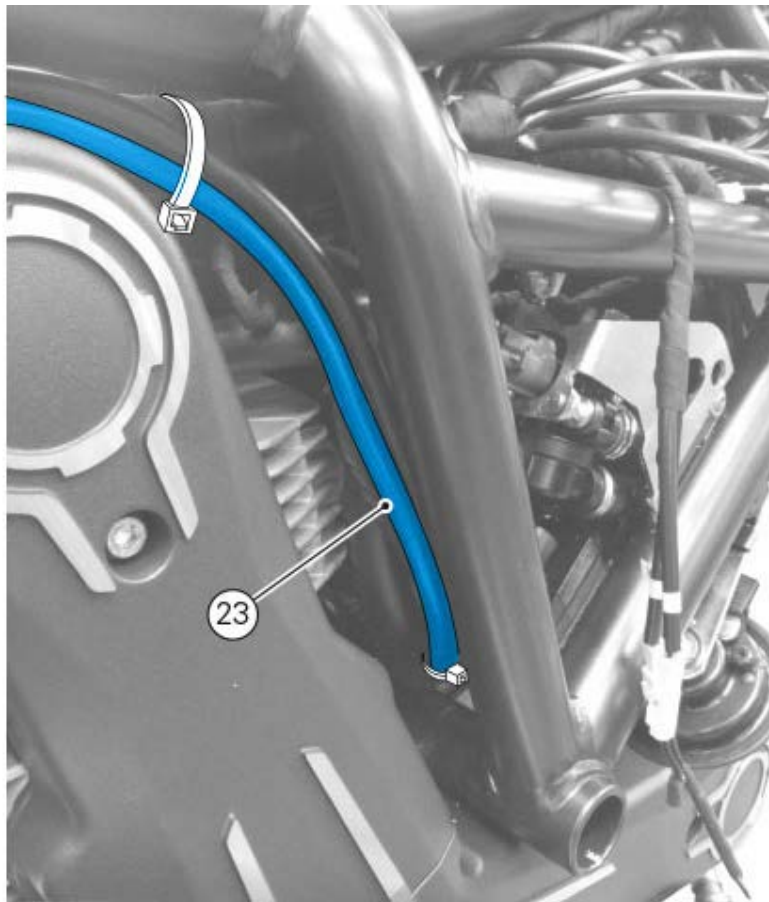

For the complete index of the wirings, divided by tables, refer to chapter "[Routing of wiring on frame](#)".

Table O

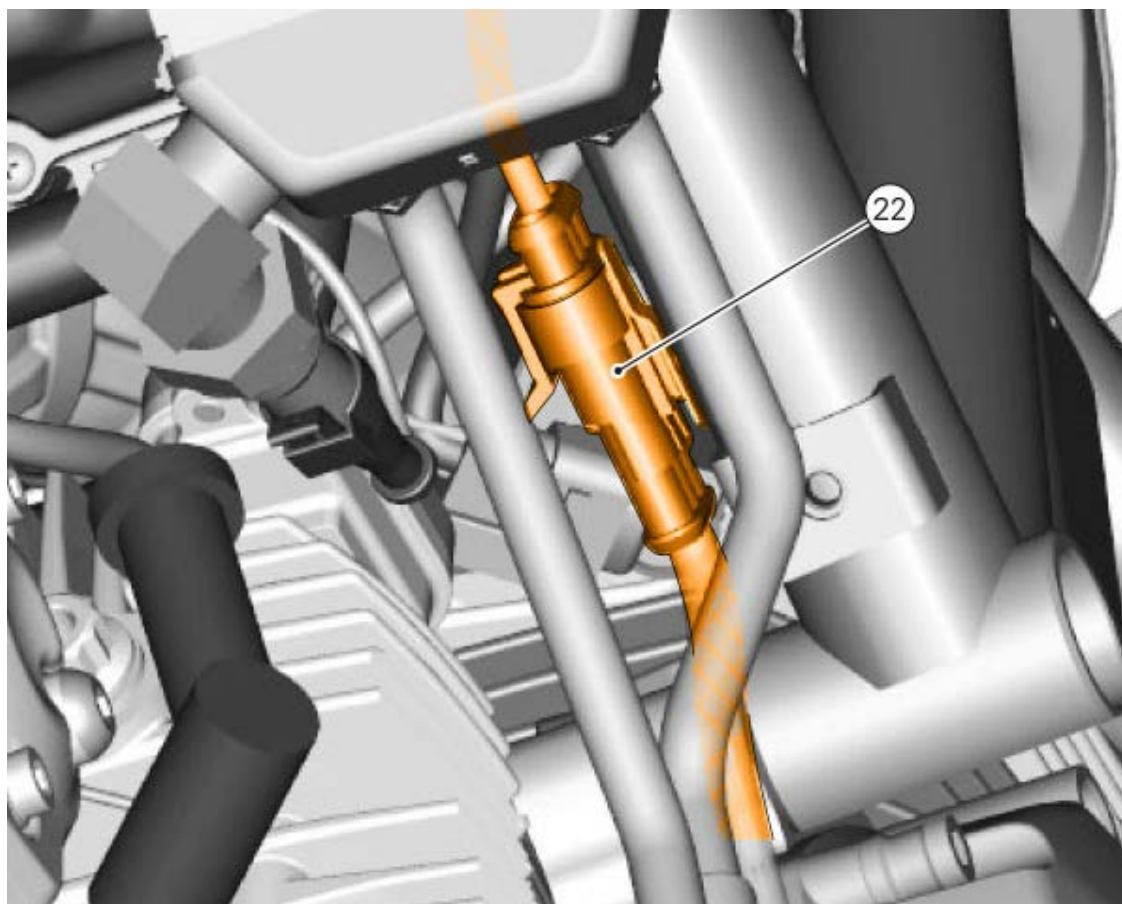
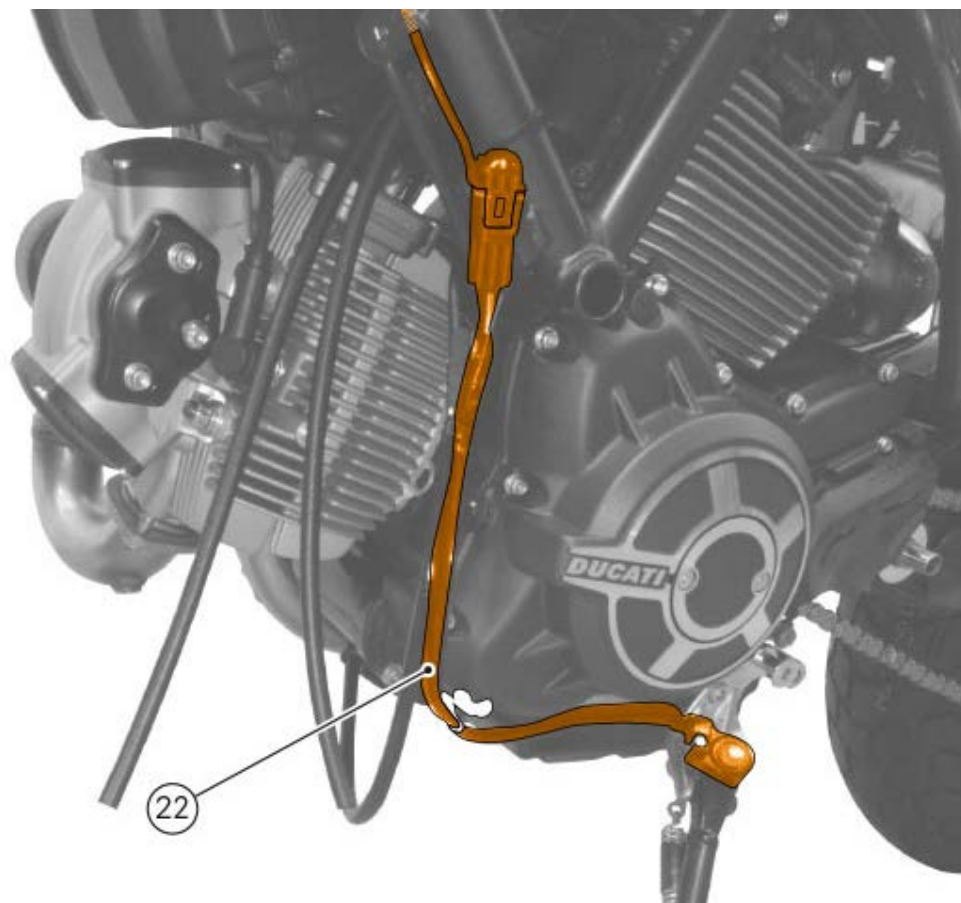

For the complete index of the wirings, divided by tables, refer to chapter "[Routing of wiring on frame](#)".

Table N

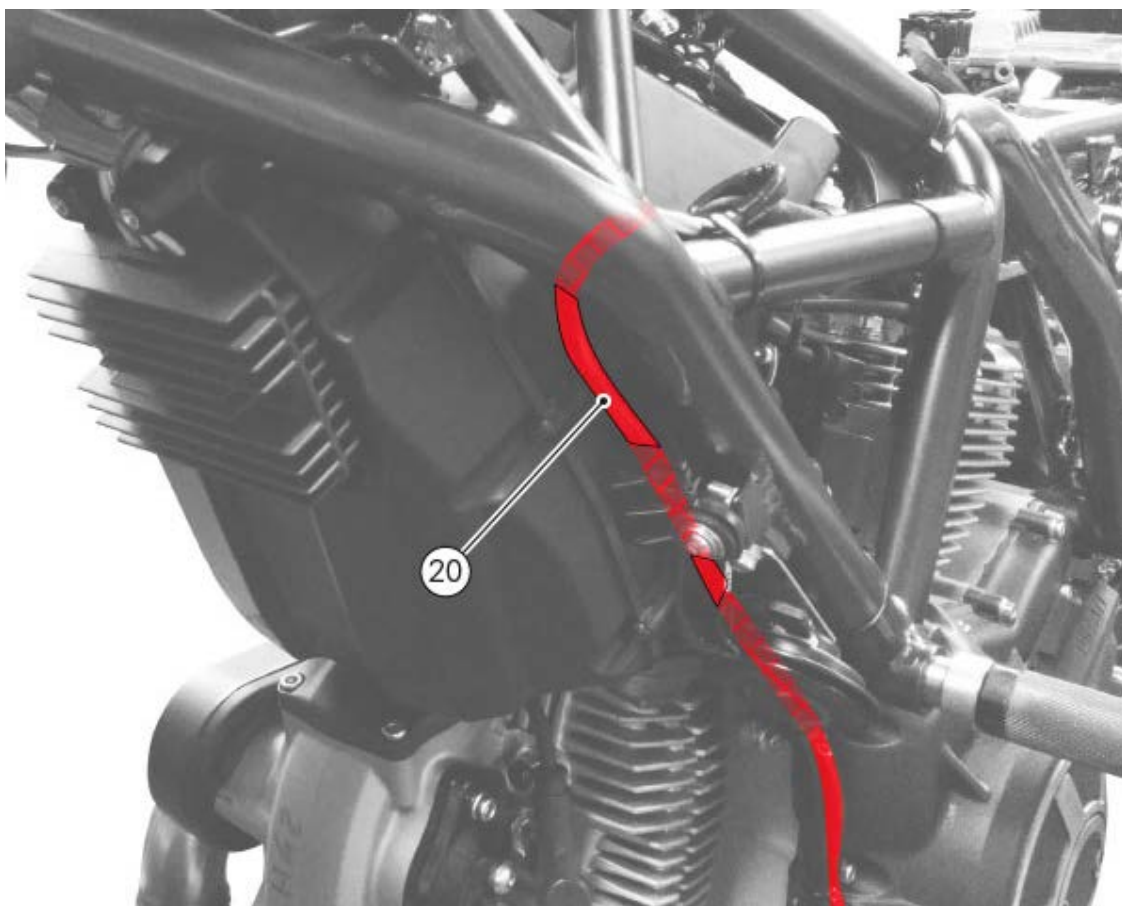
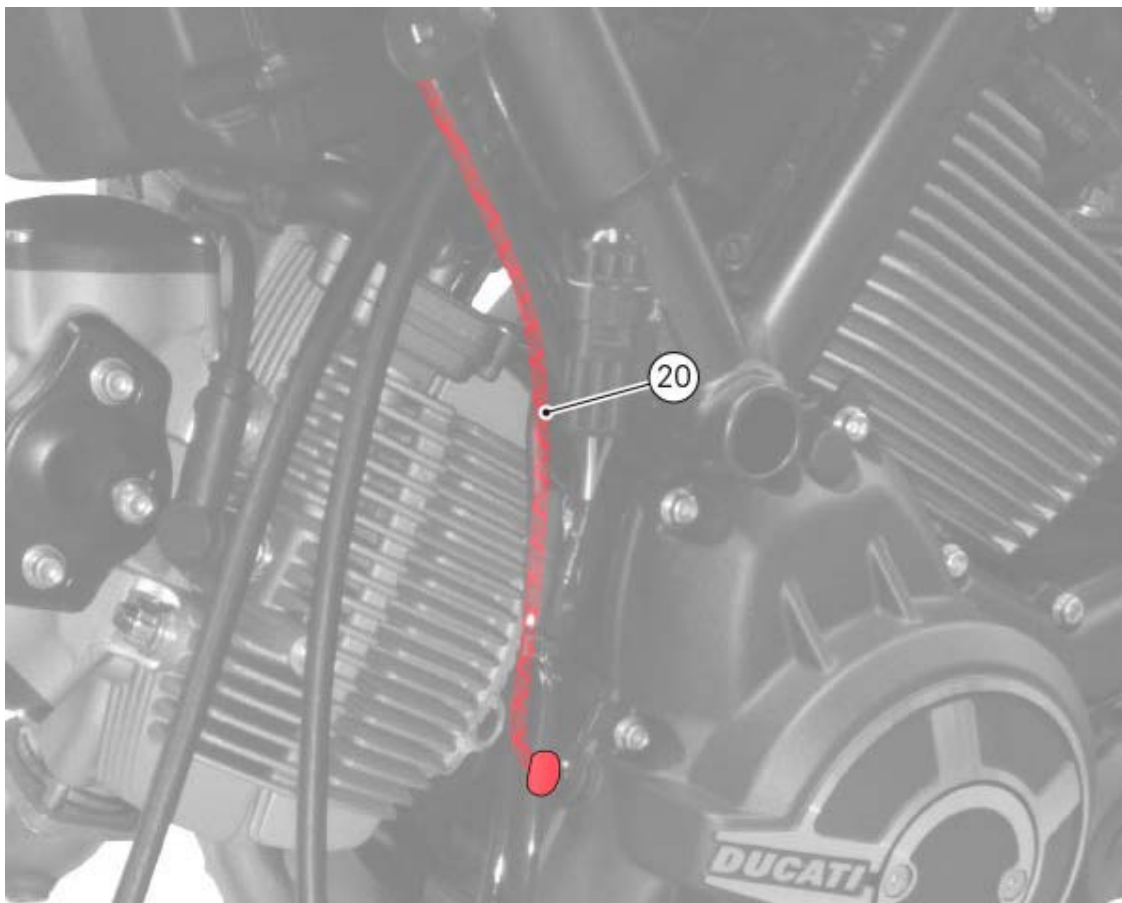

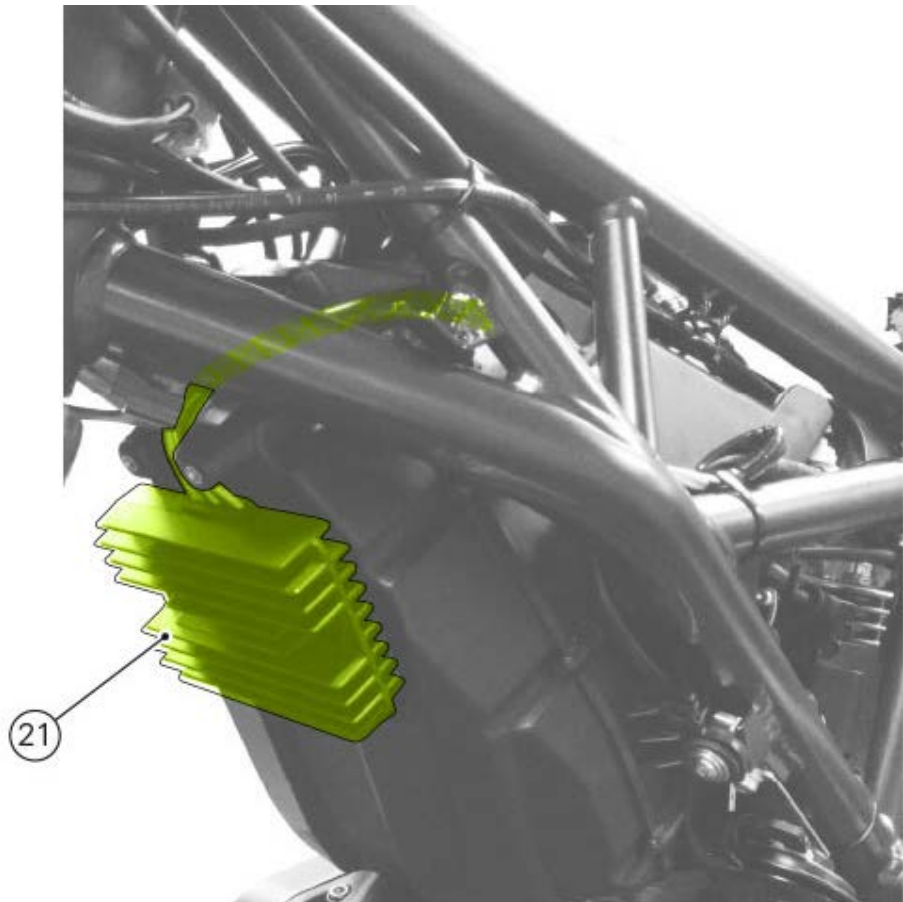
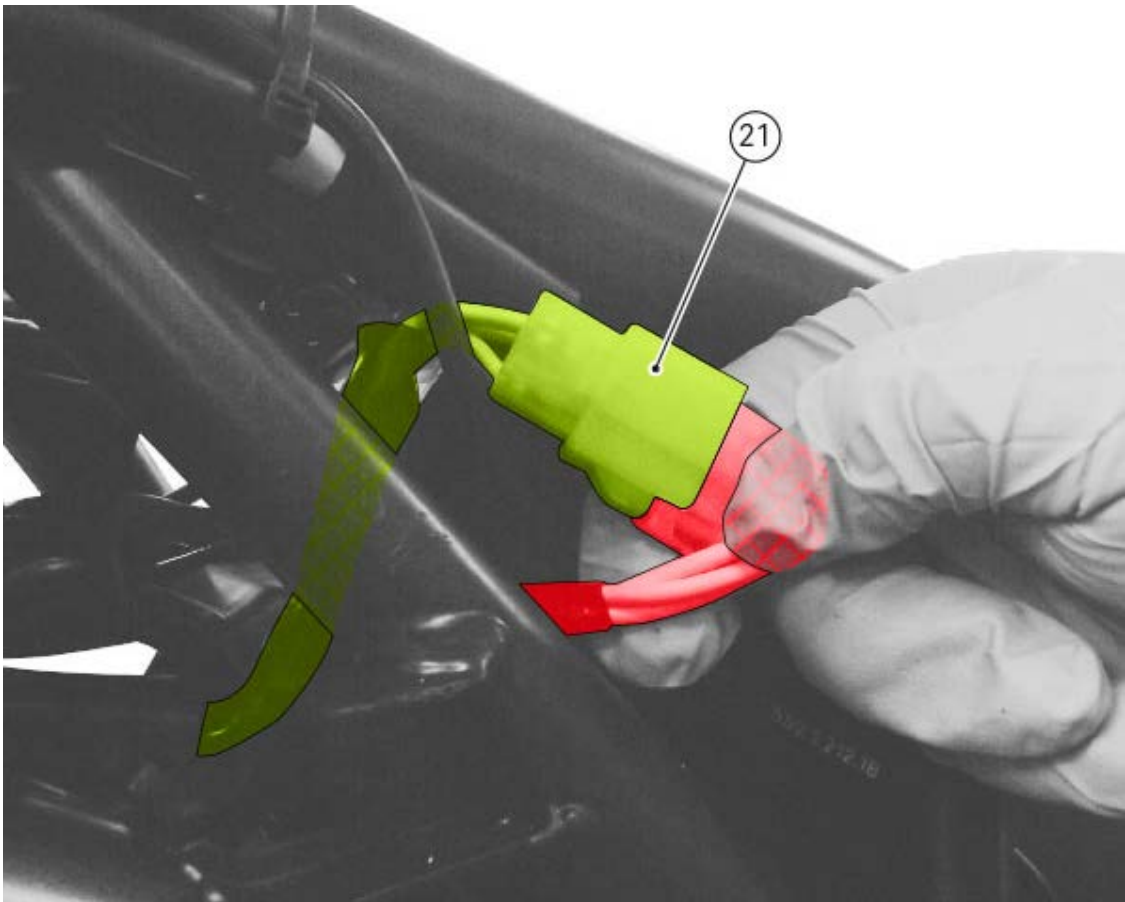

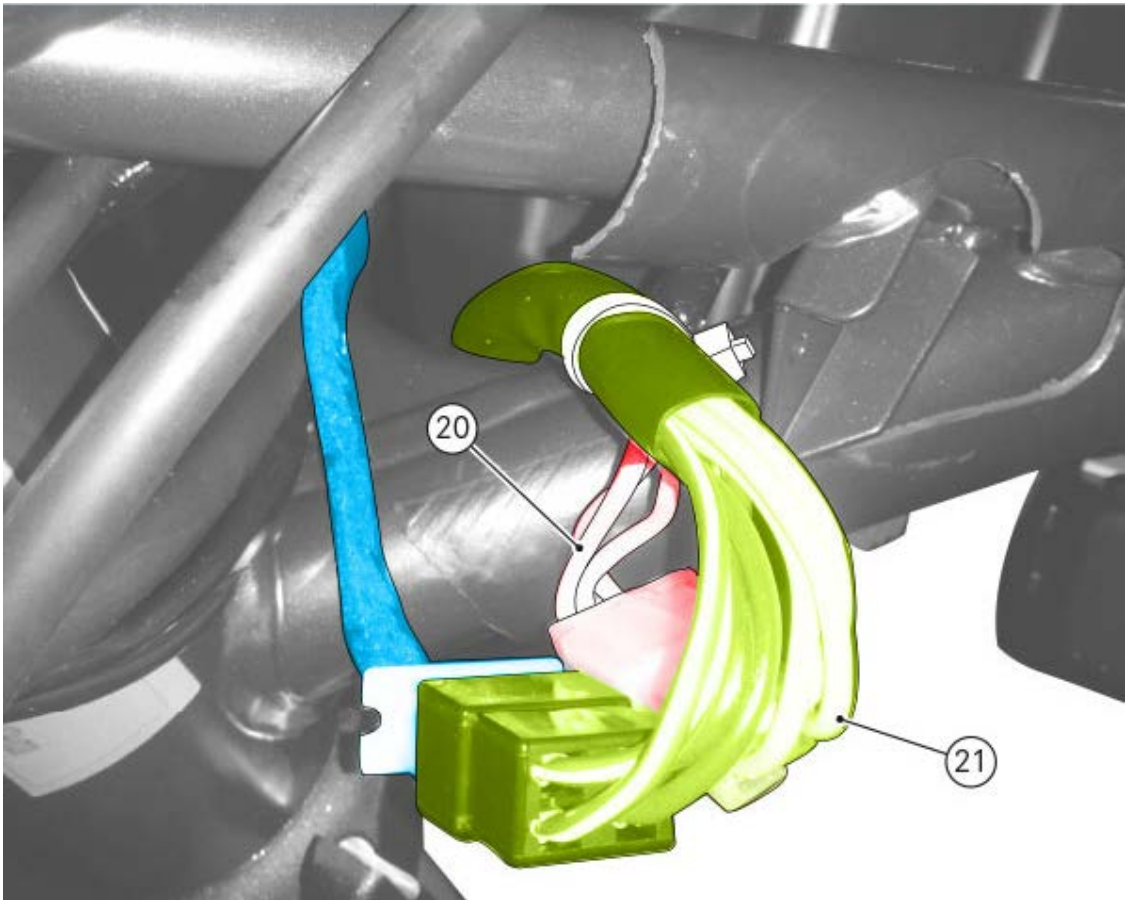
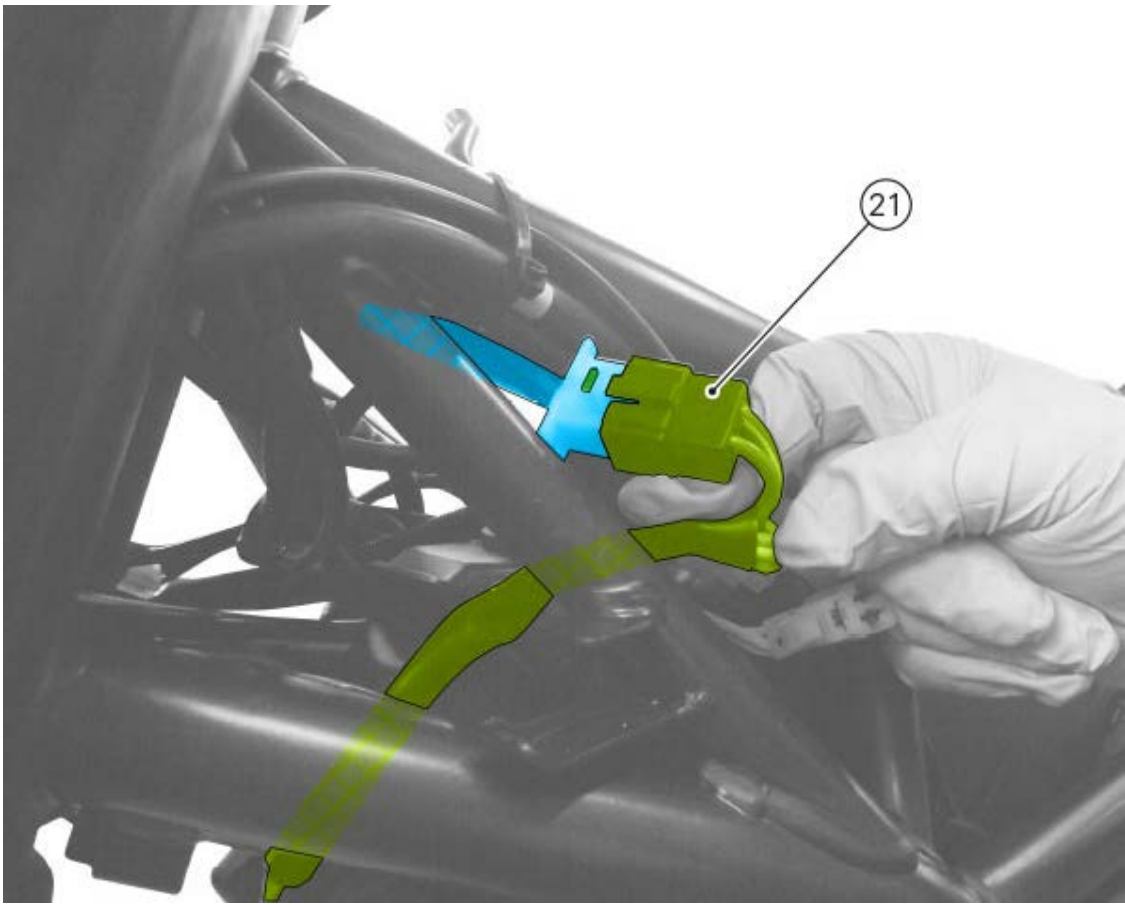

For the complete index of the wirings, divided by tables, refer to chapter "Routing of wiring on frame".

Table M

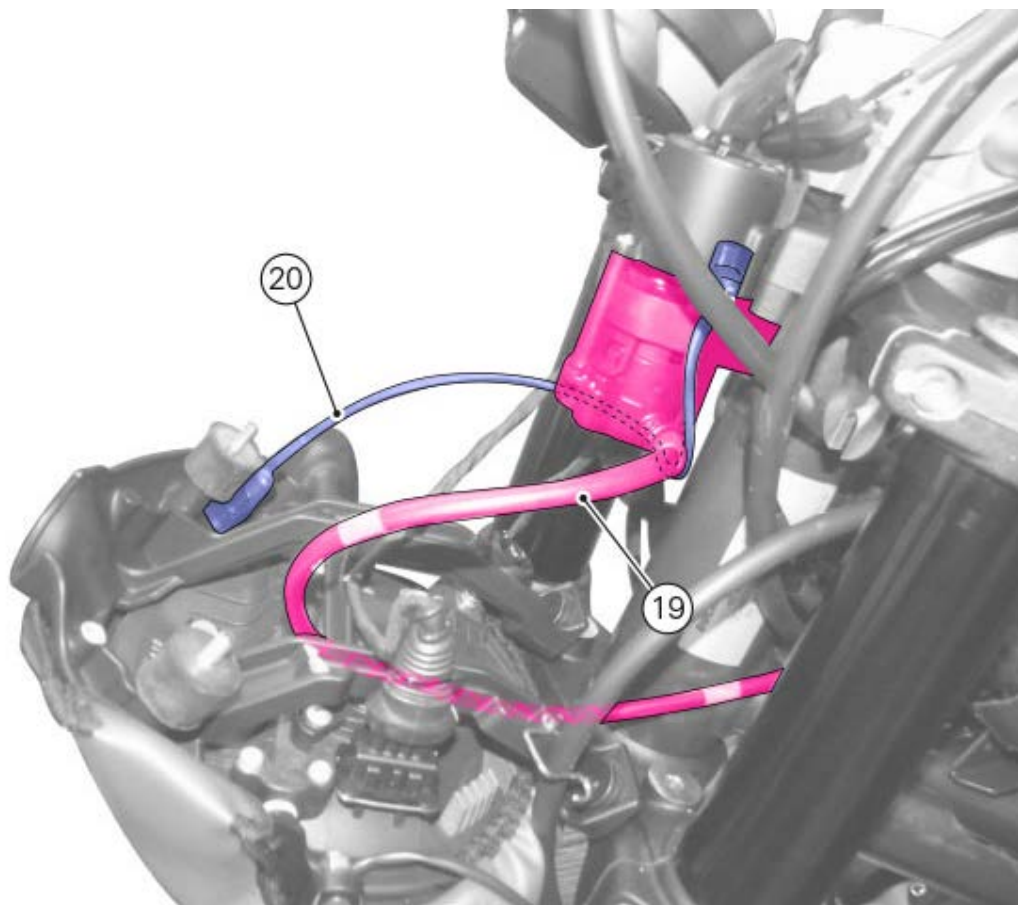

For the complete index of the wirings, divided by tables, refer to chapter "Routing of wiring on frame".

Table L

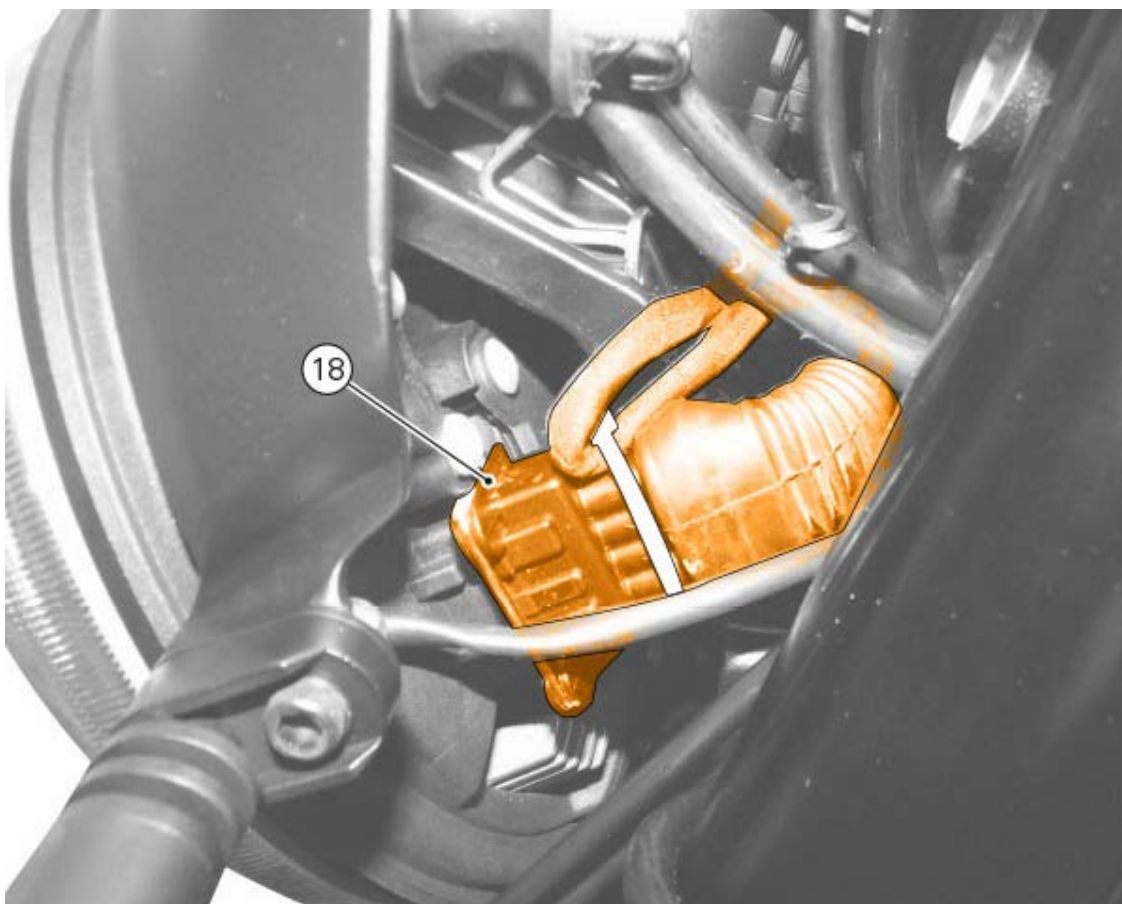
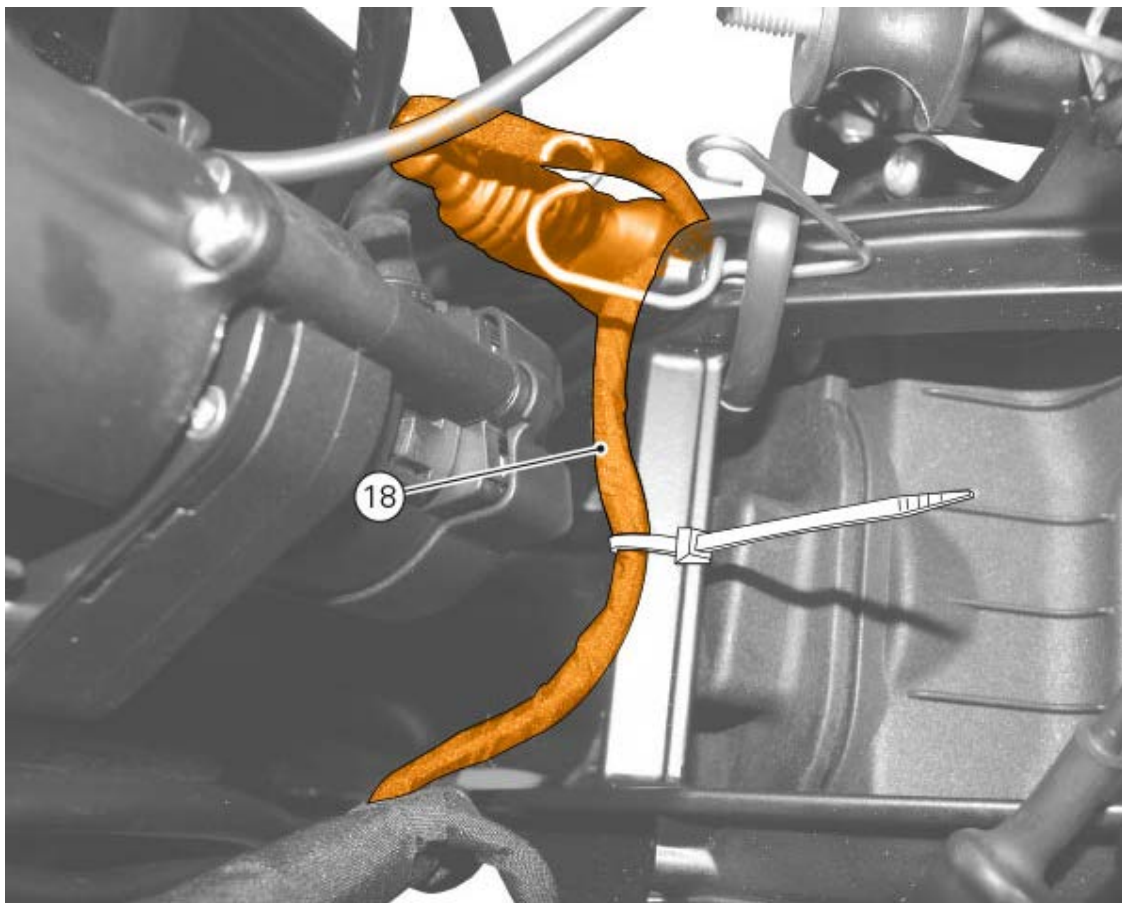

For the complete index of the wirings, divided by tables, refer to chapter "[Routing of wiring on frame](#)".

Table K

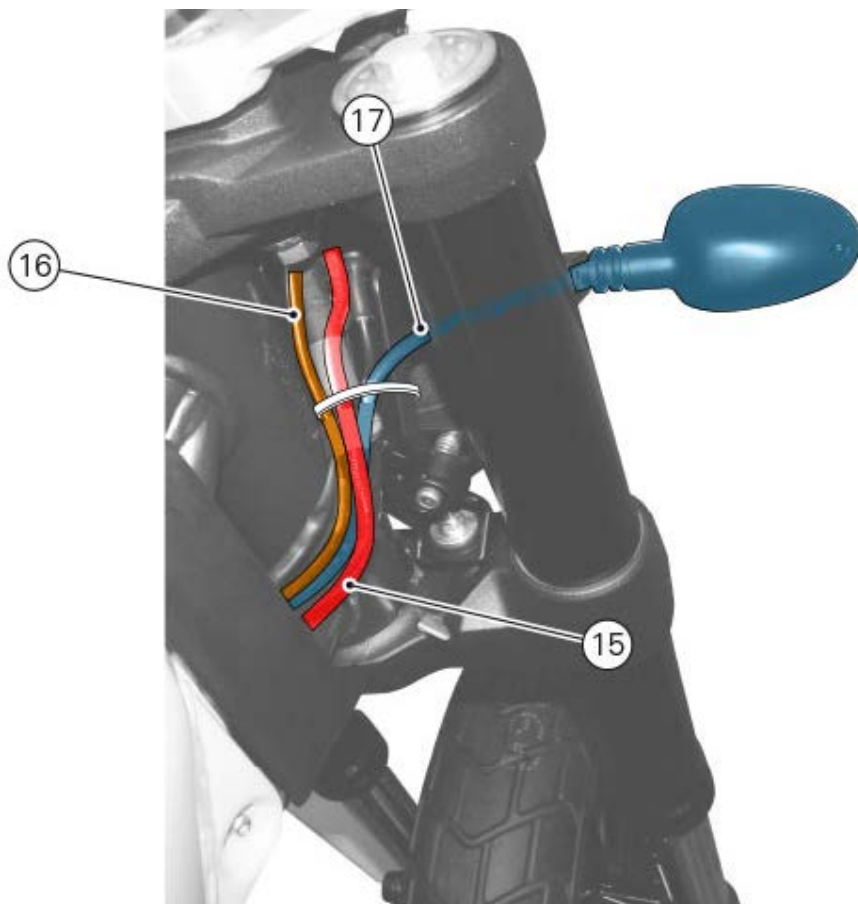
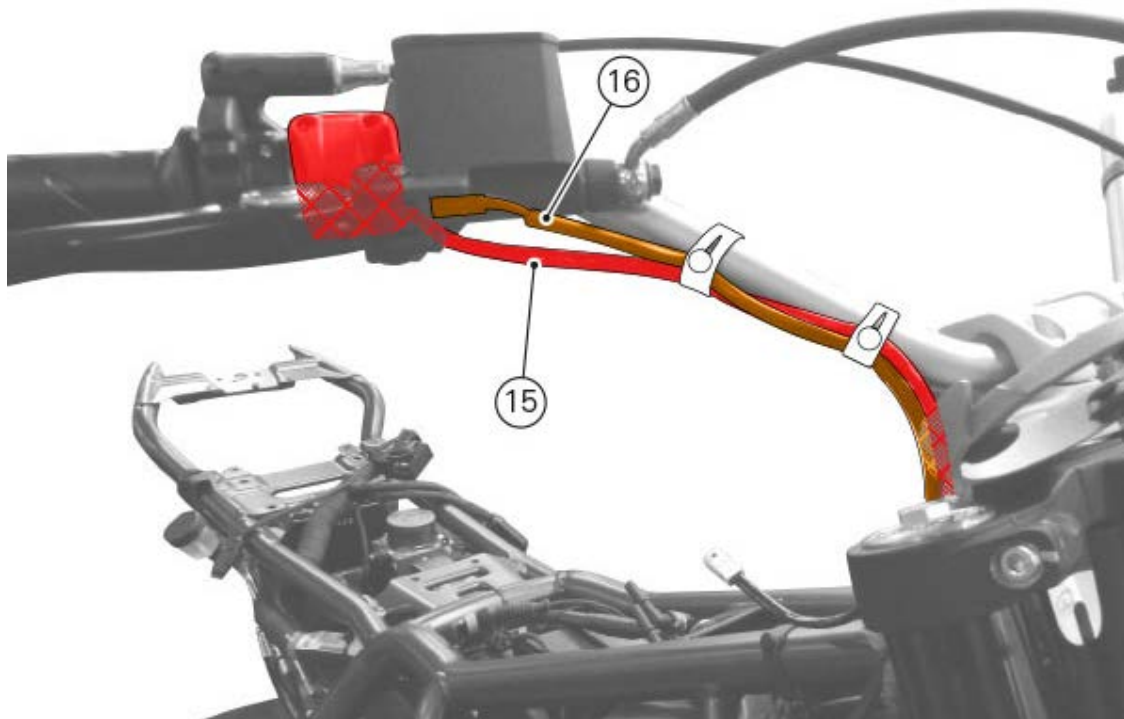

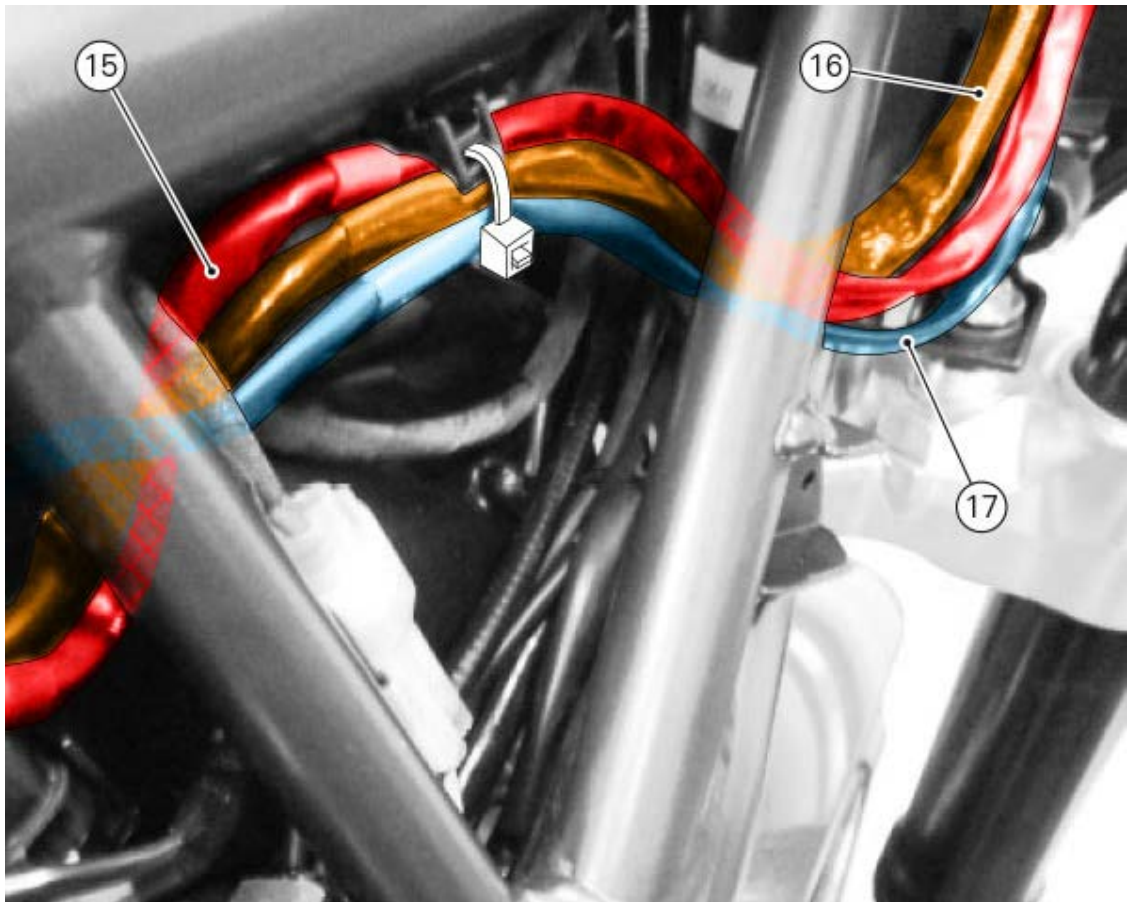
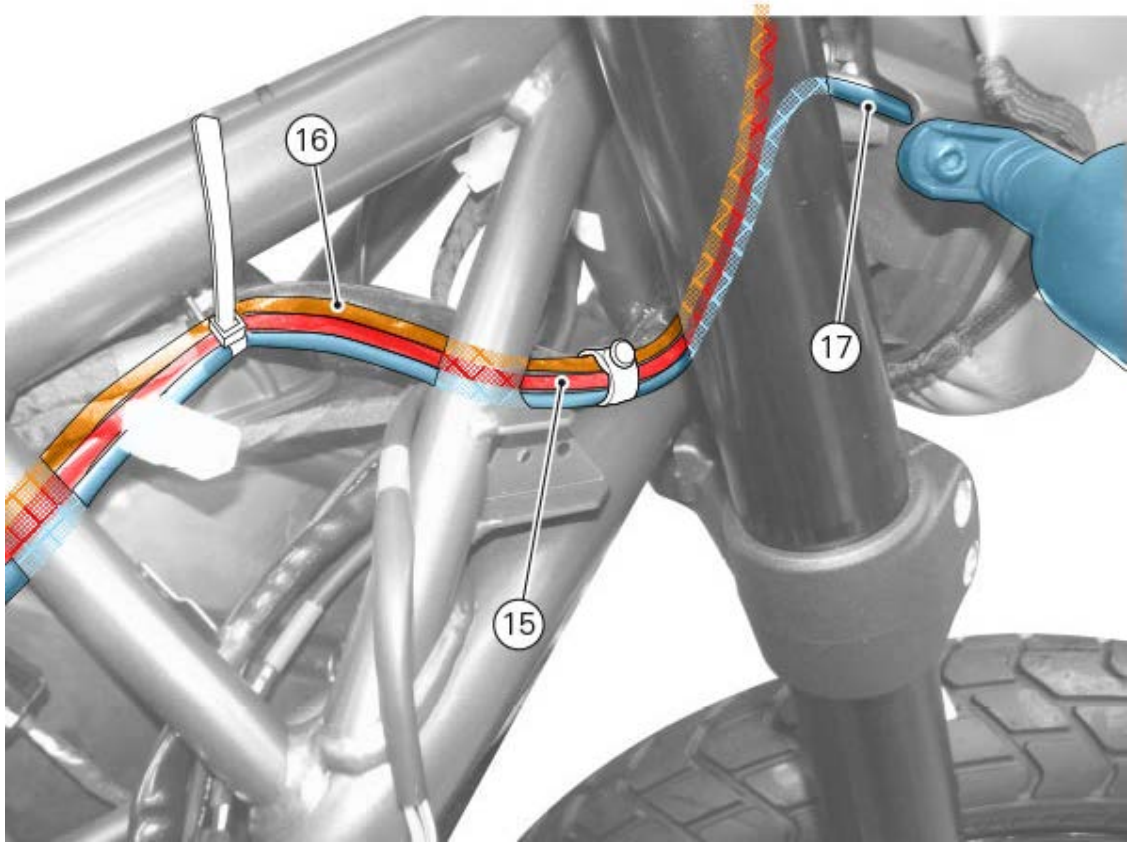

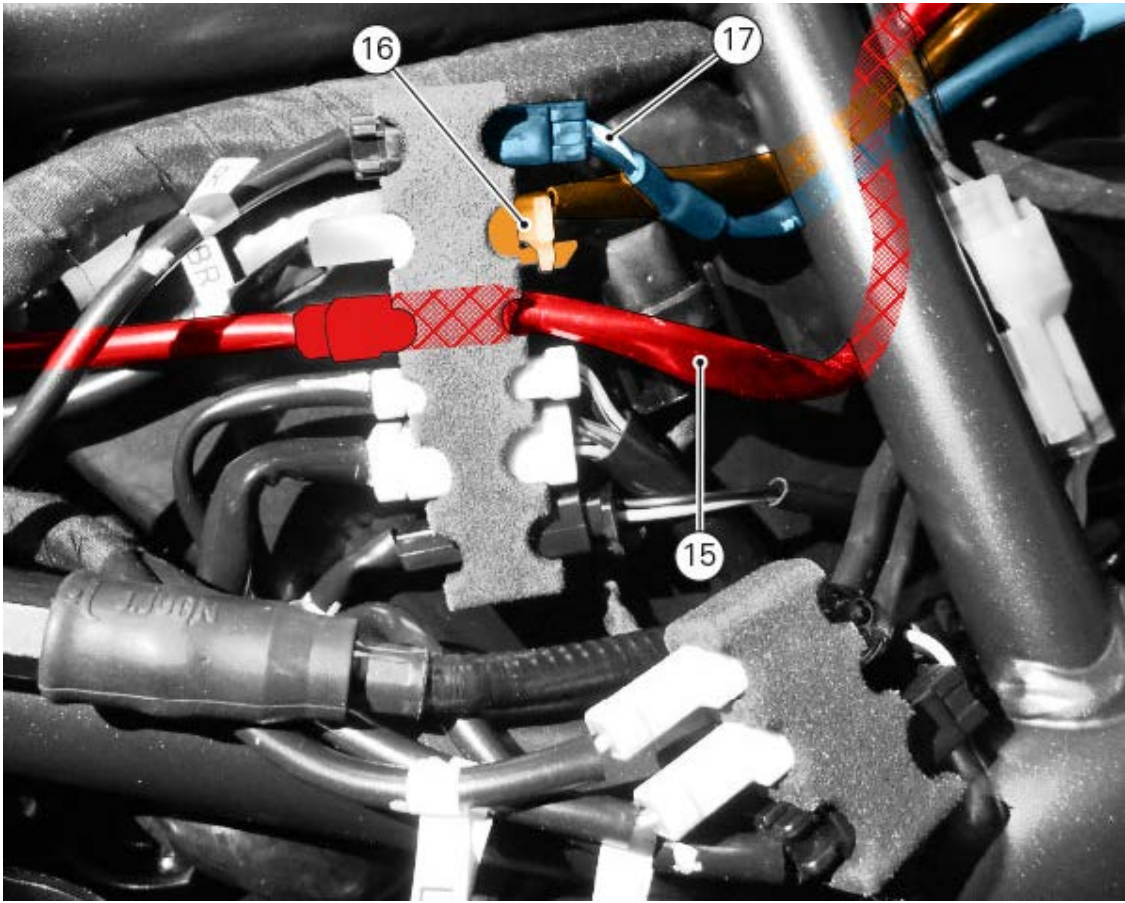

For the complete index of the wirings, divided by tables, refer to chapter "[Routing of wiring on frame](#)".

Table J

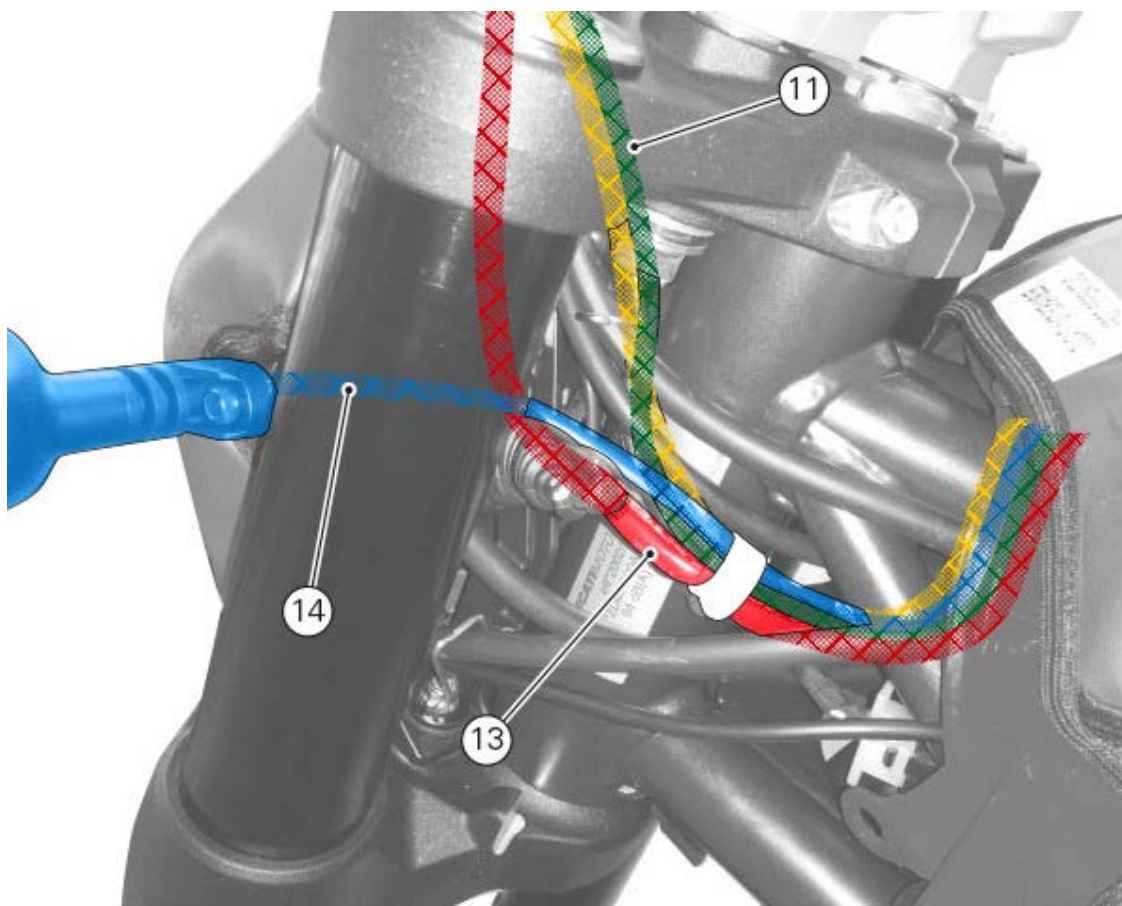
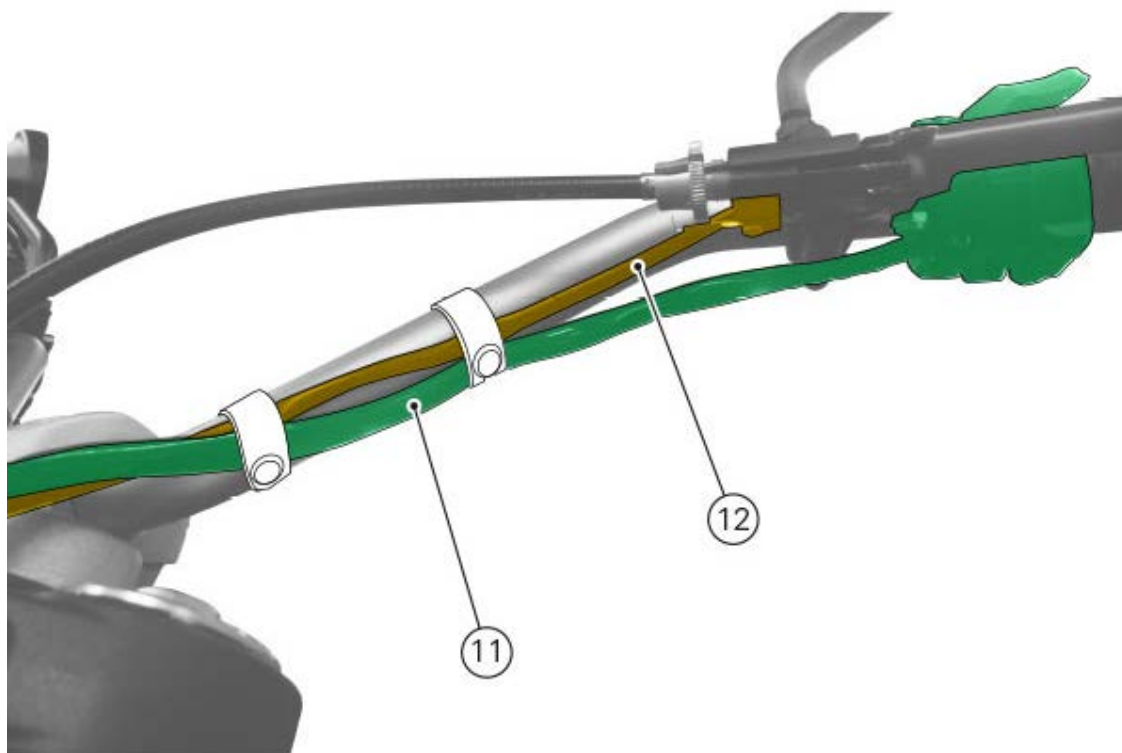

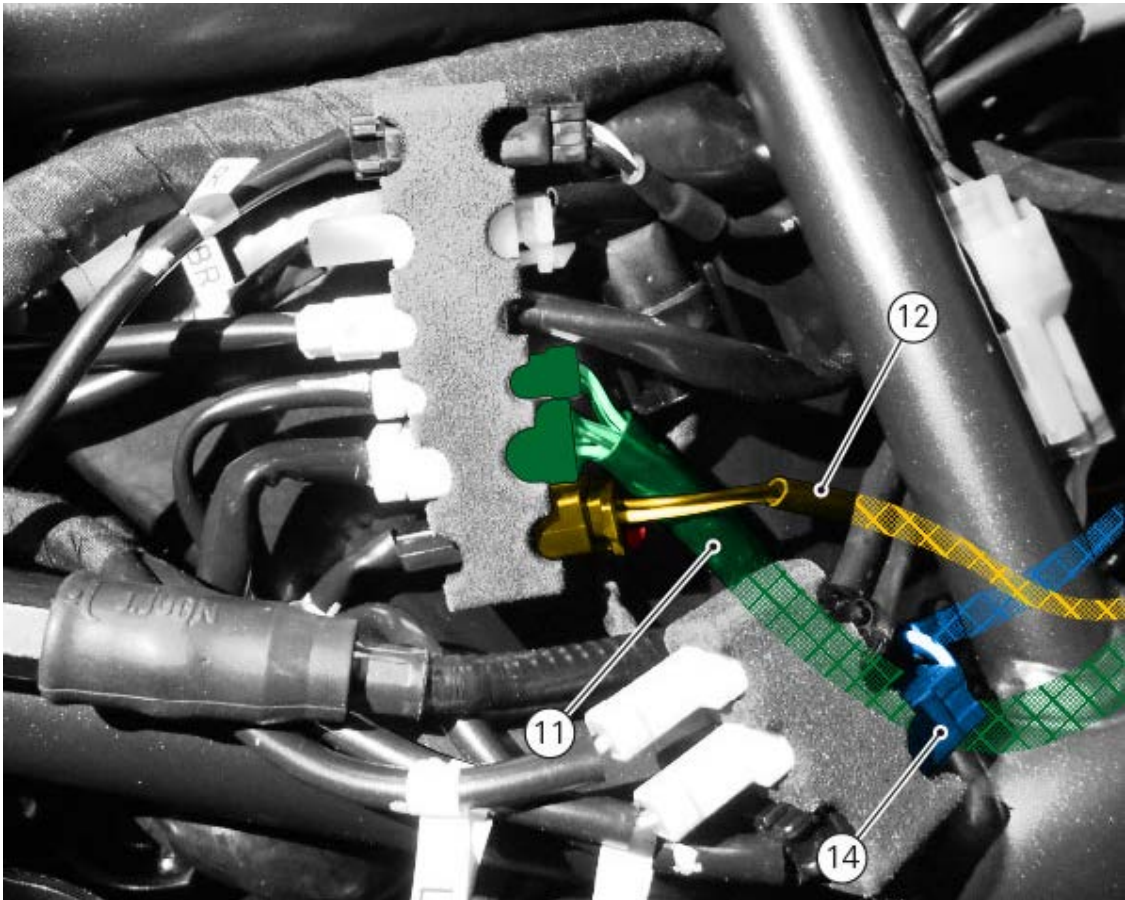
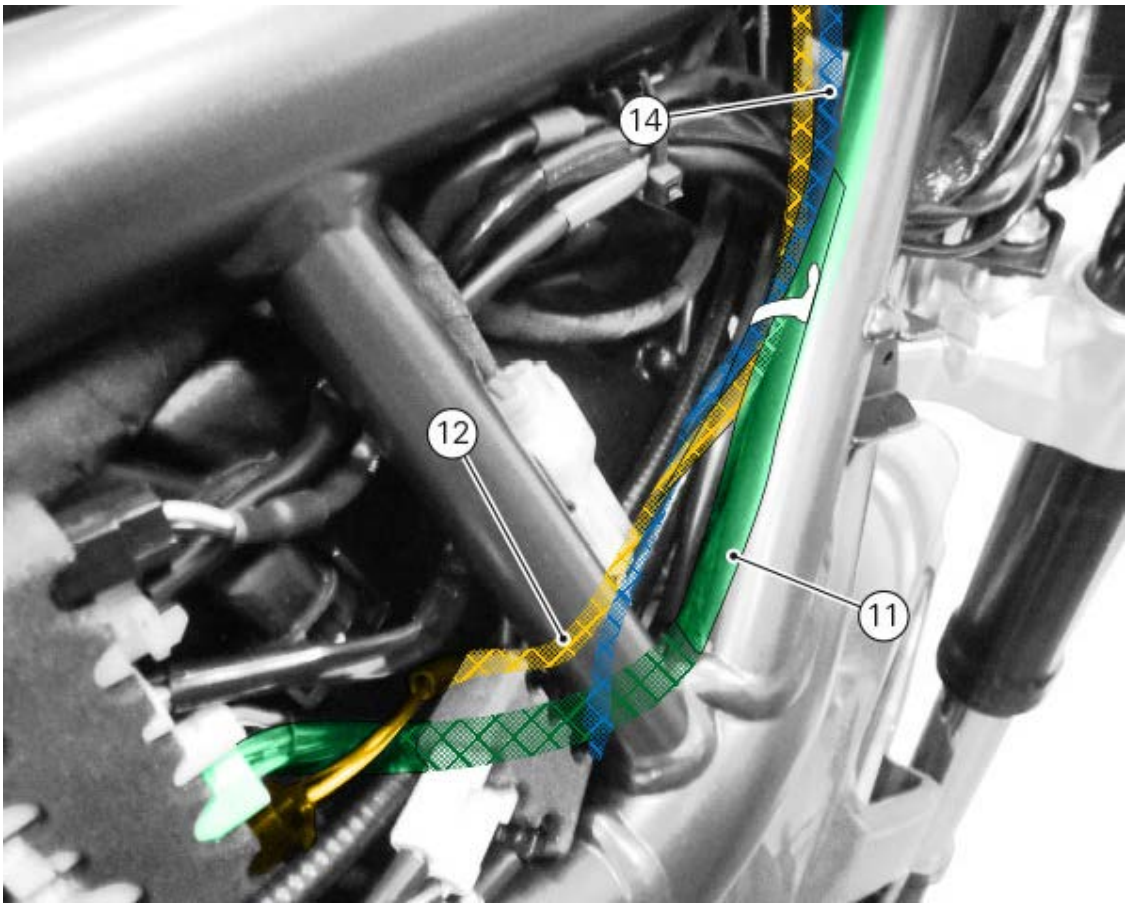

For the complete index of the wirings, divided by tables, refer to chapter "Routing of wiring on frame".

Table H

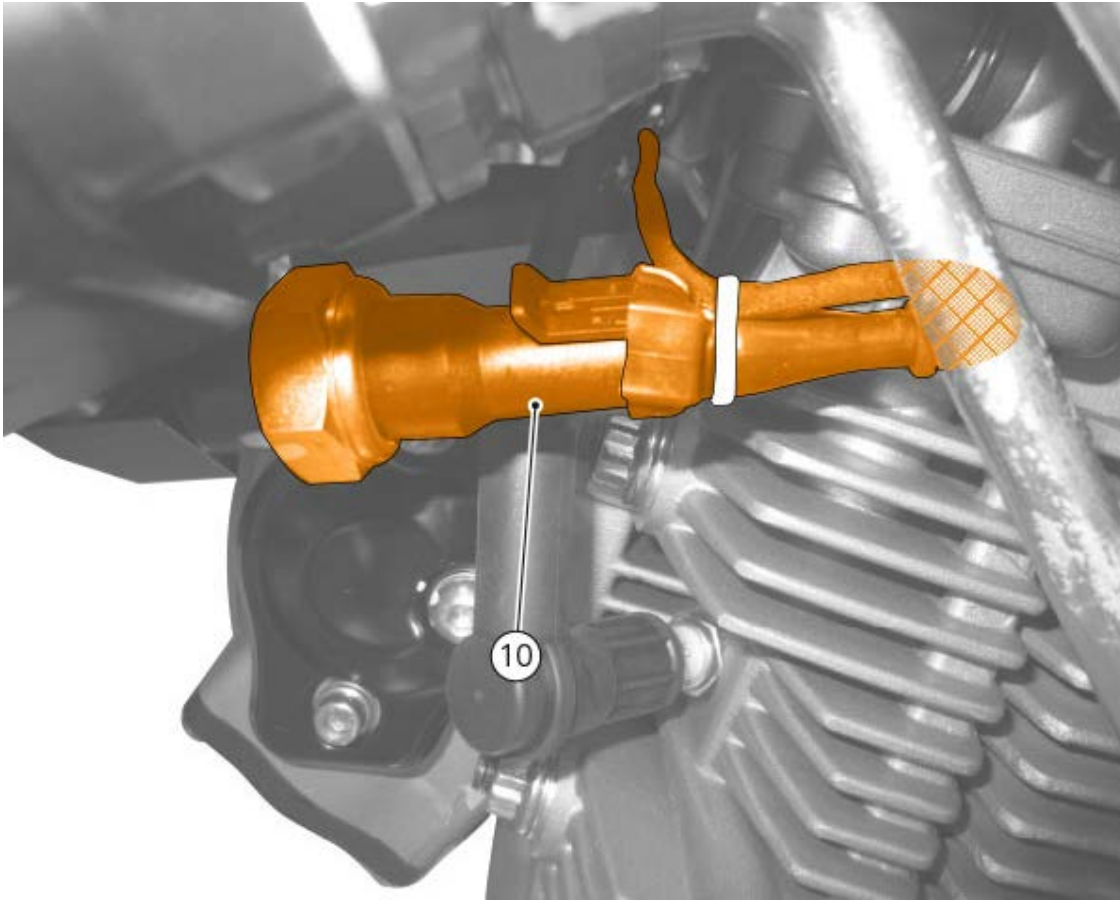

For the complete index of the wirings, divided by tables, refer to chapter "[Routing of wiring on frame](#)".

Table G

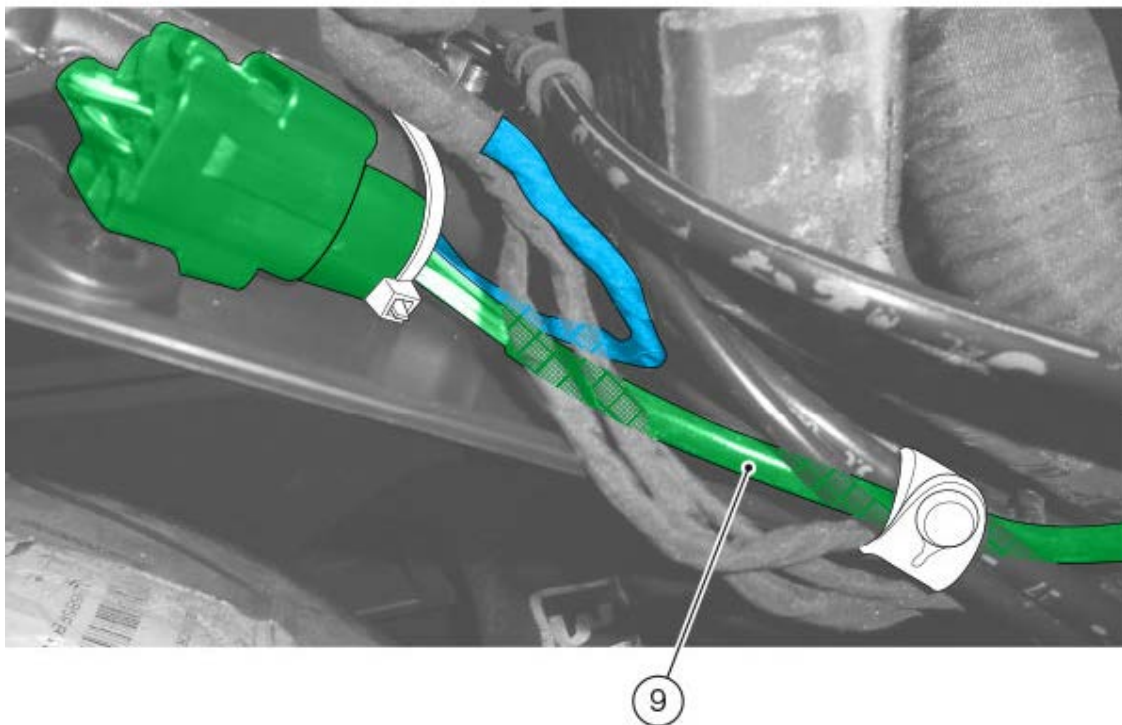

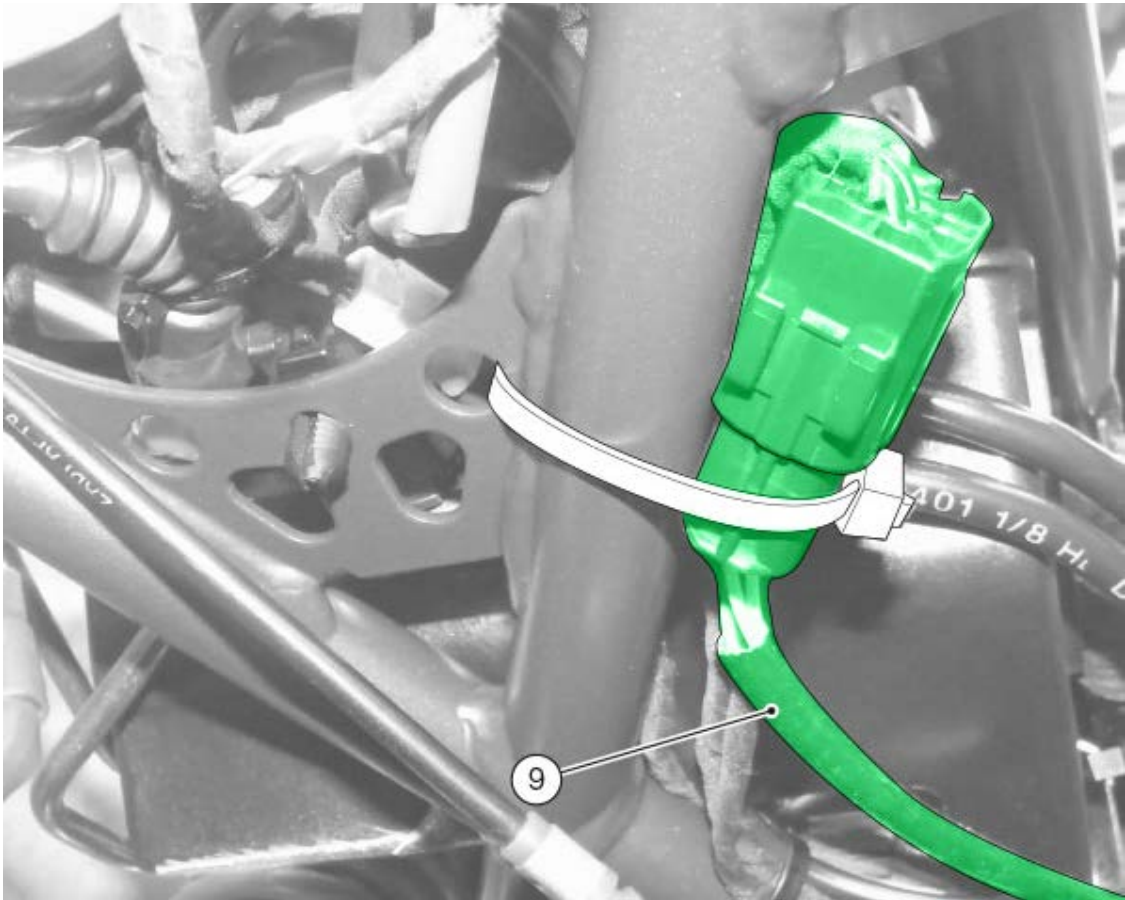

For the complete index of the wirings, divided by tables, refer to chapter "[Routing of wiring on frame](#)".

Table F

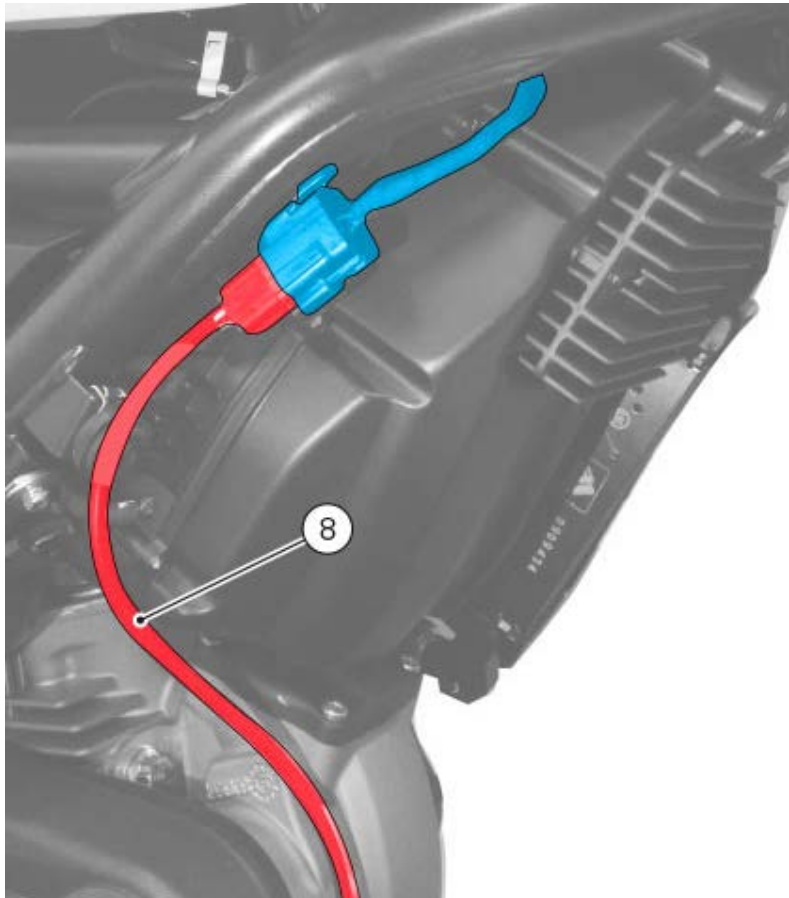
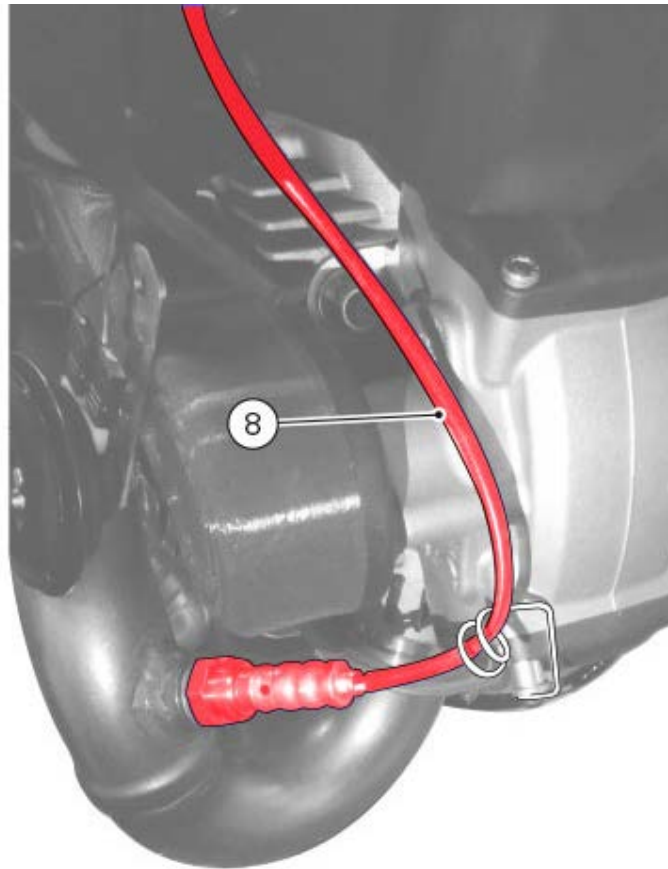

For the complete index of the wirings, divided by tables, refer to chapter "[Routing of wiring on frame](#)".

Table E

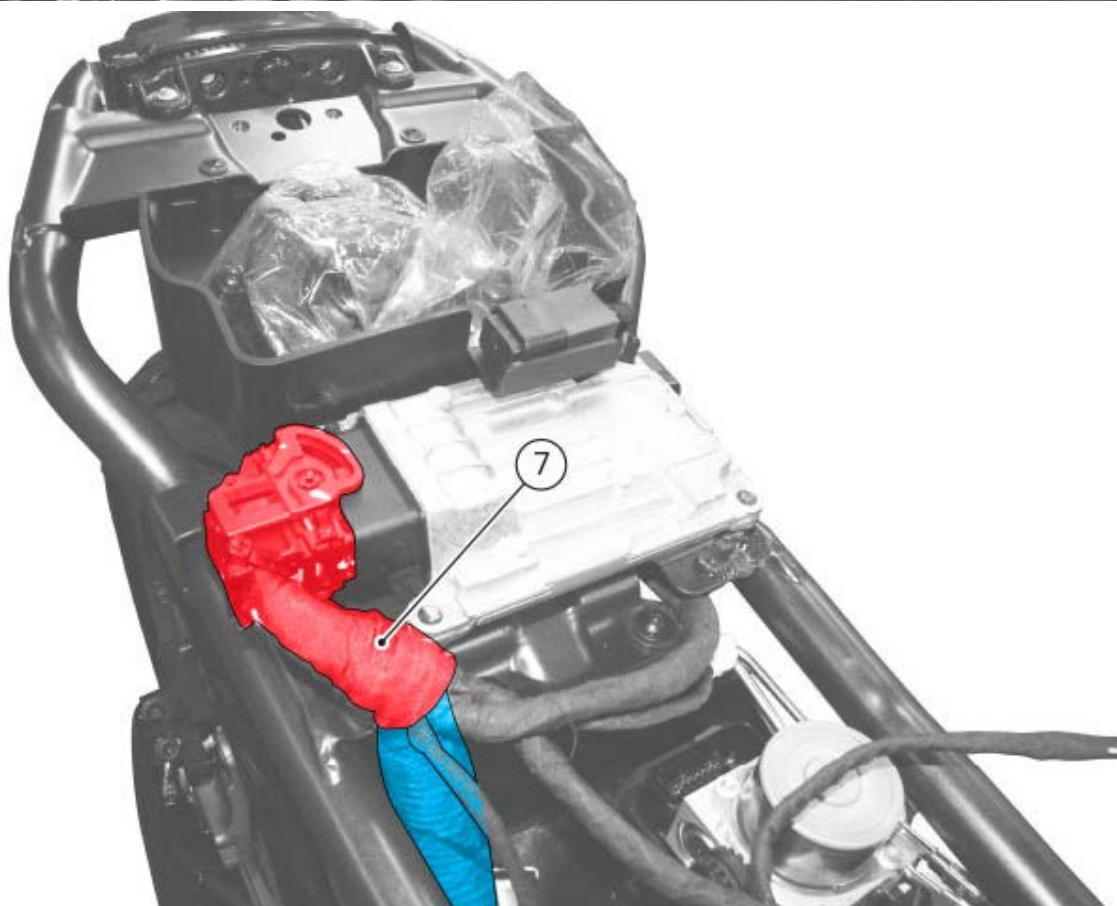
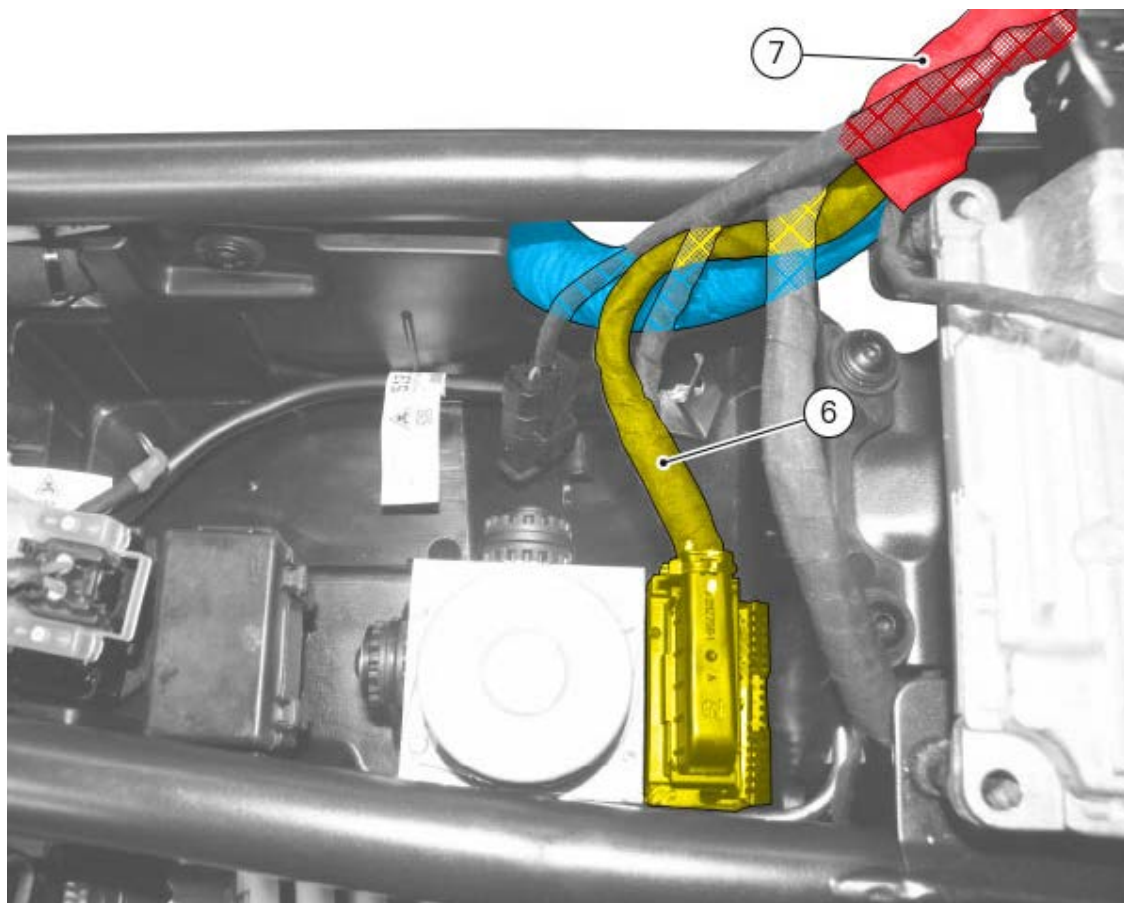

For the complete index of the wirings, divided by tables, refer to chapter "Routing of wiring on frame".

Table D

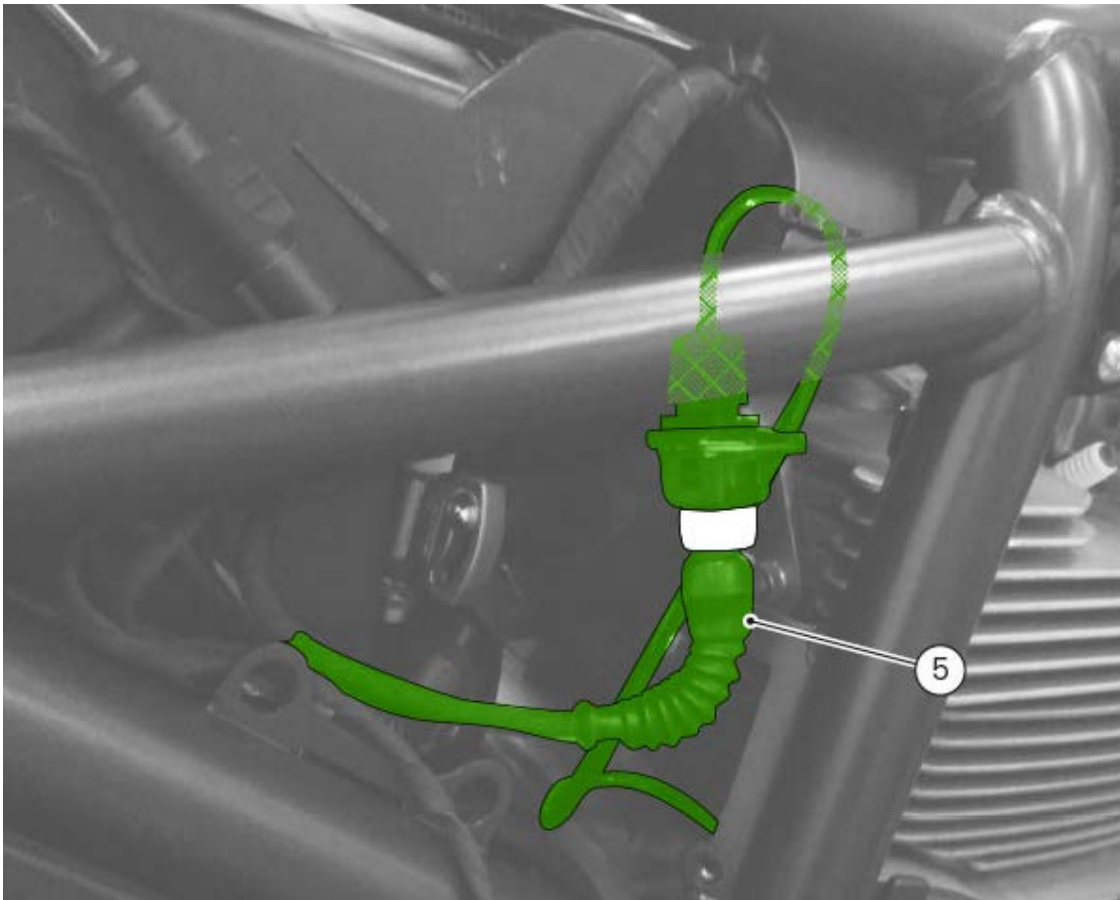

For the complete index of the wirings, divided by tables, refer to chapter "[Routing of wiring on frame](#)".

Table C

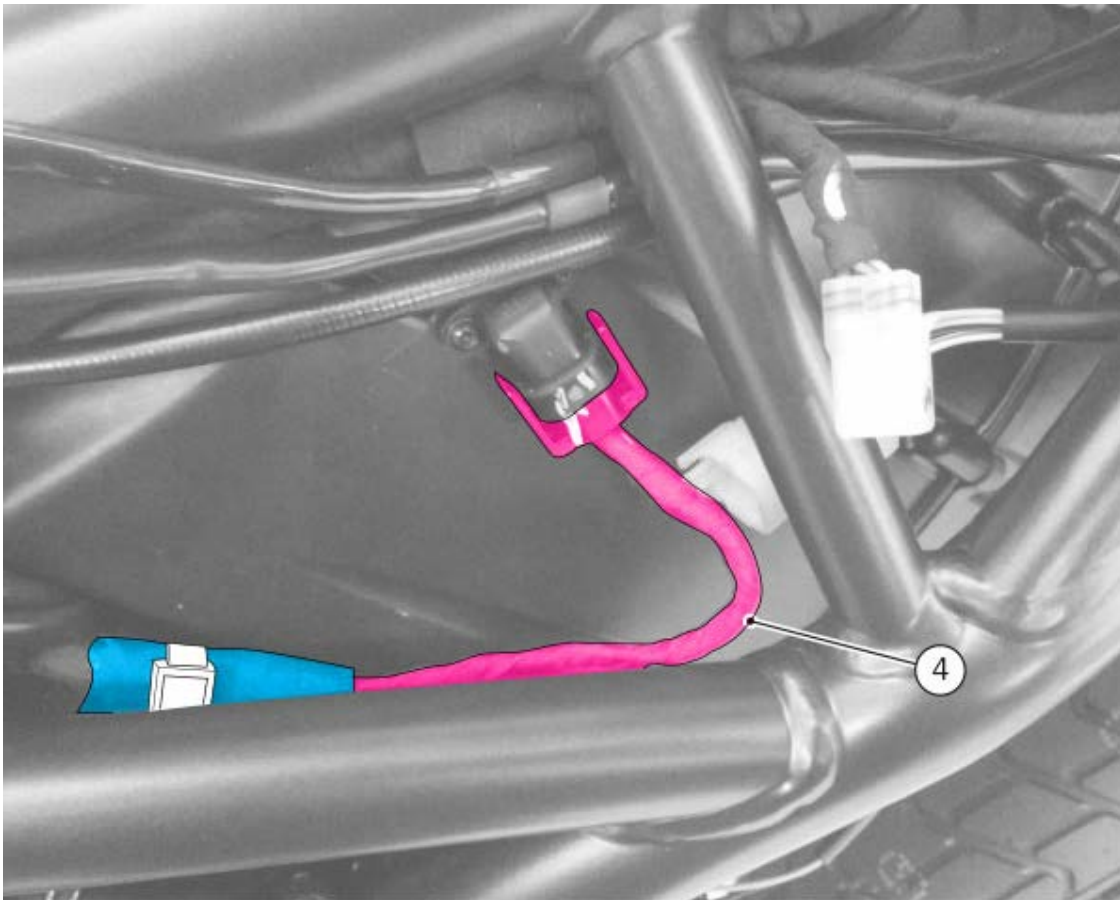

For the complete index of the wirings, divided by tables, refer to chapter "[Routing of wiring on frame](#)".

Table A

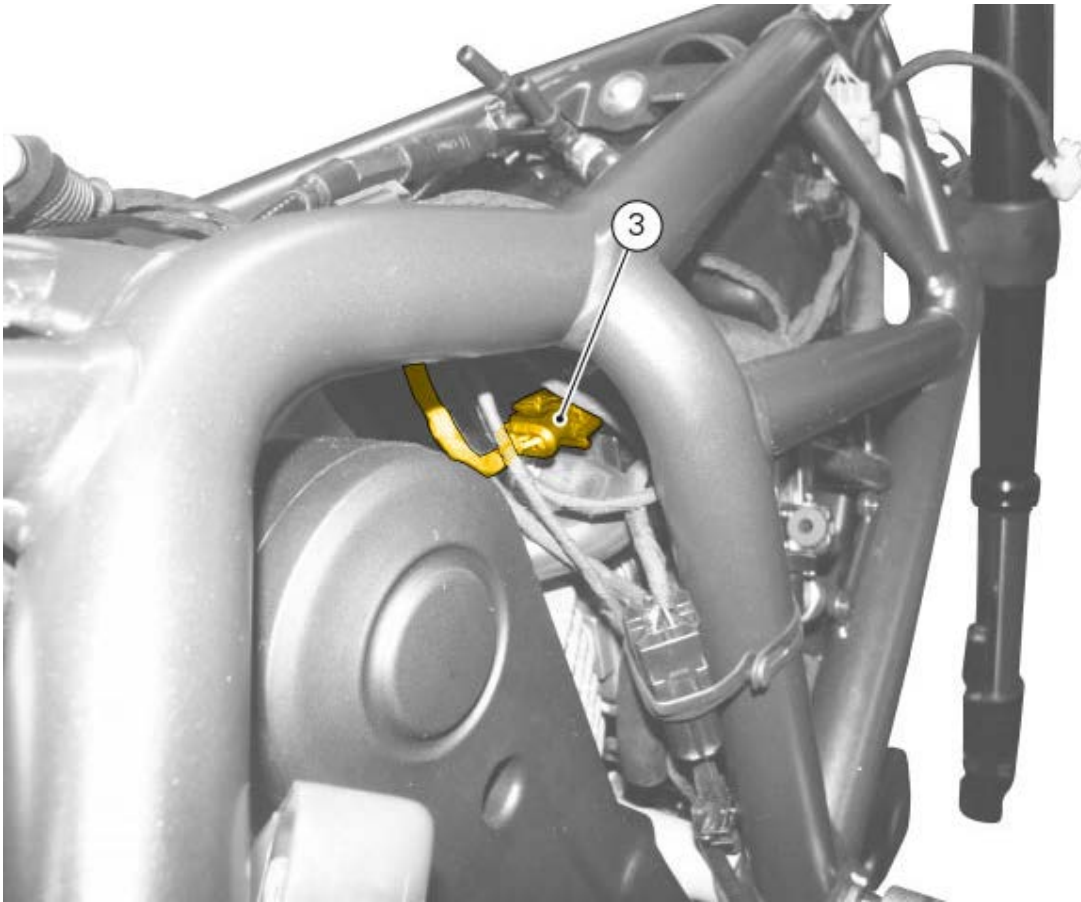

For the complete index of the wirings, divided by tables, refer to chapter "[Routing of wiring on frame](#)".

TABLE A

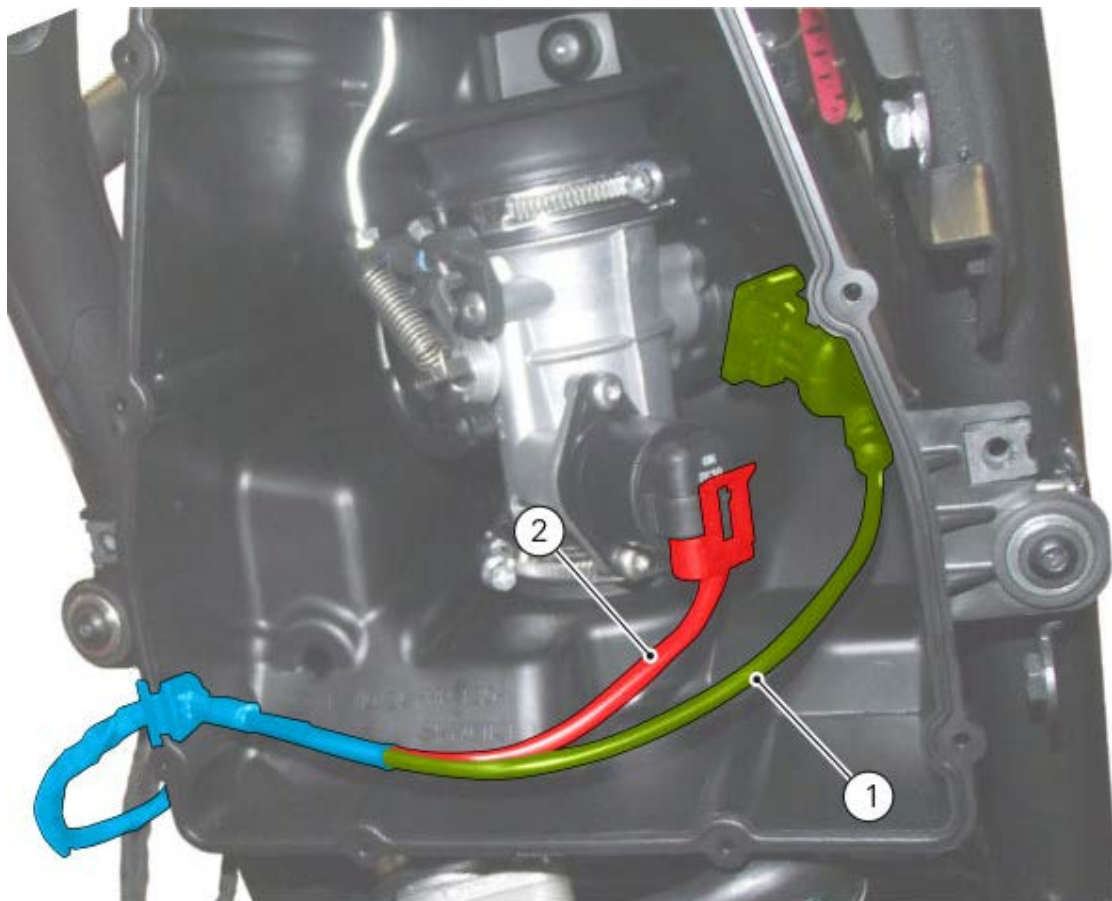

For the complete index of the wirings, divided by tables, refer to chapter "[Routing of wiring on frame](#)".

Routing of wiring on frame

TABLE	NAME	REF.
TABLE A	TPS	1
	Stepper	2
TABLE B	Map Sensor	3
TABLE C	Air T.	4
TABLE D	Pick up	5
TABLE E	ABS	6
	ECU	7
TABLE F	Horizontal lambda sensor	8
TABLE G	Vertical lambda sensor	9
TABLE H	Engine pressure sensor	10
TABLE J	Left-hand switch	11
	Clutch switch	12
	Key switch	13
	Left turn indicator	14
TABLE K	Right-hand switch	15
	Front brake switch	16
	Right turn indicator	17
TABLE L	Headlight	18
TABLE M	Key switch	19
	Immobiliser	20
TABLE N	Generator cable	20
	Voltage regulator	21
TABLE O	Side stand switch	22
TABLE P	Starter motor	23
TABLE Q	Ground cable	24
TABLE R	Vertical head spark plug cable	25
TABLE S	Horizontal head spark plug cable	26
TABLE T	Vertical injector	27
TABLE U	Horizontal injector	28

TABLE V	Neutral switch	29
TABLE W	Rear wheel speed sensor	30
TABLE X	Tail light cable	31
TABLE Y	Rear turn indicator	32
	Left turn indicator	33
TABLE Z	Engine temperature	34
TABLE AA	Front speed sensor	35
TABLE BB	Instrument panel	36
TABLE CC	Number plate light cable	37
TABLE DD	Horn	38

Fuse box key

Fuse box key		
Pos.	El. item	Rat.
1	Key-on	10 A
2	El. loads	15 A
3	Instrument panel	10 A
4	Control unit	5 A
5	Injection	20 A
6	ABS motor	25 A
7	ABS	10 A

Wire colour coding

B Blue
W White
V Violet
Bk Black
Y Yellow
R Red
Lb Light blue
Gr Grey
G Green
Bn Brown
O Orange
P Pink

Key to wiring diagram

- 1 Front stop switch
- 2 Clutch switch
- 3 Right-hand switch
- 4 Key switch
- 5 Left-hand switch
- 6 Fuse box
- 7 Mobile phone power socket
- 8 Bluetooth Module
- 9 ABS control unit
- 10 Starter motor
- 11 Fused solenoid
- 12 Battery
- 13 Alarm
- 14 Rectifier
- 15 Generator
- 16 Rear right turn indicator
- 17 Tail light
- 18 Rear left turn indicator
- 19 Number plate light
- 20 Fuel unit
- 21 Fuel pump ground
- 22 Main relay
- 23 Fuel pump relay
- 24 Vertical lambda sensor
- 25 Horizontal lambda sensor
- 26 Horizontal spark plug
- 27 Horizontal coil
- 28 Vertical spark plug
- 29 Vertical coil
- 30 Horizontal injector
- 31 Vertical injector
- 32 Potentiometer drive (TPS)
- 33 Secondary air actuator
- 34 MAP sensor
- 35 Oil temperature sensor
- 36 ECT sensor
- 37 Rear speed sensor
- 38 Side stand switch
- 39 Gear sensor
- 40 Oil pressure switch
- 41 Rear stop light
- 42 Data Acquisition / Diagnosis (DDA)
- 43 Timing/rpm sensor
- 44 Air temperature sensor
- 45 Control unit
- 46 Stepper motor
- 47 Front speed sensor
- 48 Transponder antenna
- 49 Instrument panel
- 50 LH heated handgrip

Rectifier-regulator

Regulator (1) is located on the front side of the airbox.



The rectifier/regulator consists of an aluminium casing containing the diodes that rectify the current produced by the generator. It also contains an electronic device that regulates the current supplied by the generator in accordance with battery voltage.

If the battery is drained, the current has the value necessary to restore optimum operating conditions of the battery itself.

While, if the battery is fully charged, the current value will be lower.



Note

Check the charging current by using the "DDS 2" diagnosis instrument.

Removing the regulator

Disconnect the voltage regulator connector (2) and the generator connector (3).
Loosen the two front screws (4) on regulator (1) and remove regulator.

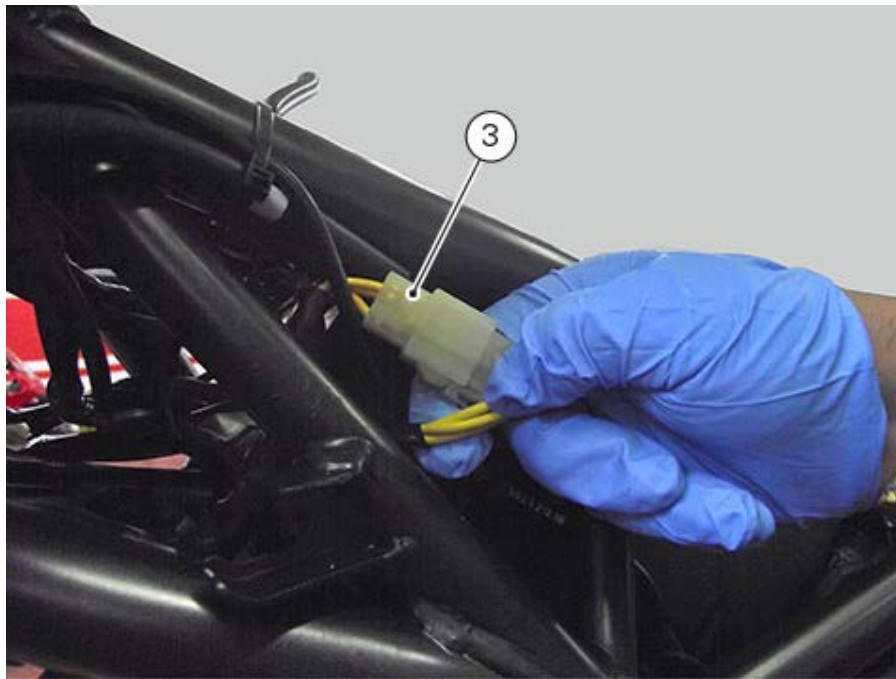

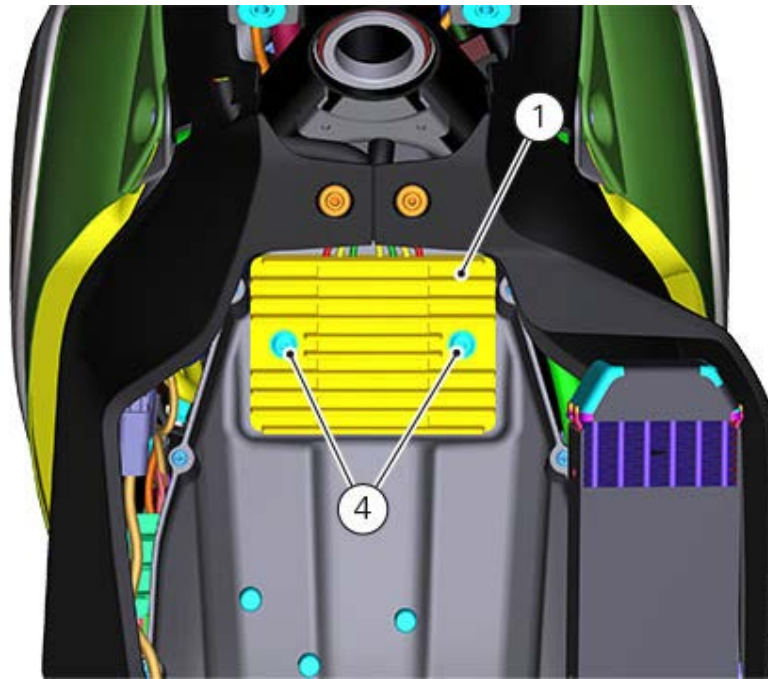

Refitting the regulator

Position the regulator (1) on the support.
Tighten the screws to the specified torque of $10 \text{ Nm} \pm 10\%$.
Connect the connectors (2) and (3).



Important

Do not disconnect the battery cables when engine is running because this would cause irreparable damage to the regulator.

Regulator fuse

The 30 A fuse, positioned inside electromagnetic switch (5), protects the electronic regulator.

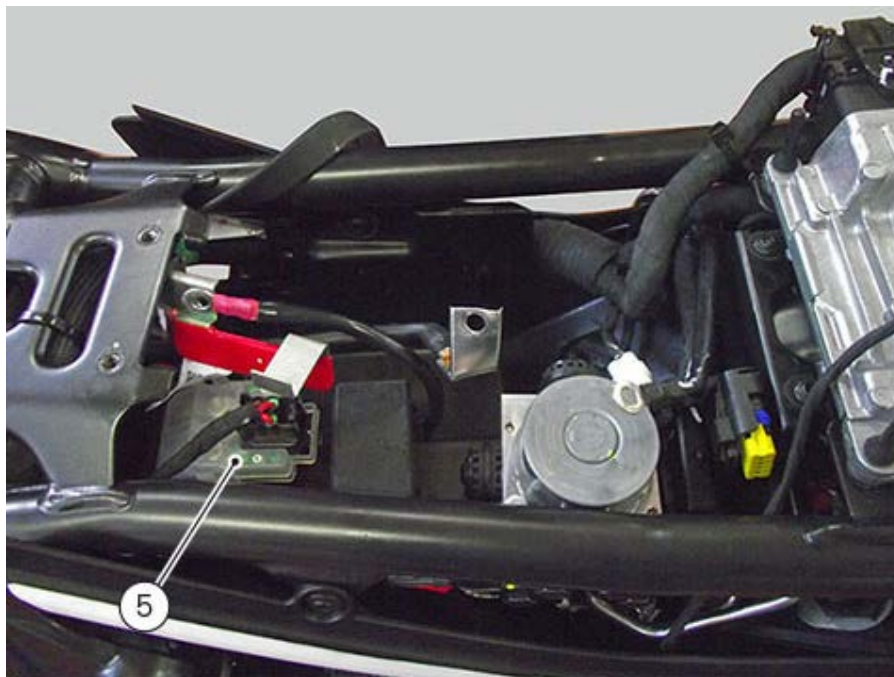

Remove the seat ([Removing the seat](#)).

To reach the fuse, disconnect connector (6), remove protection cap (7) and remove fuse (A).

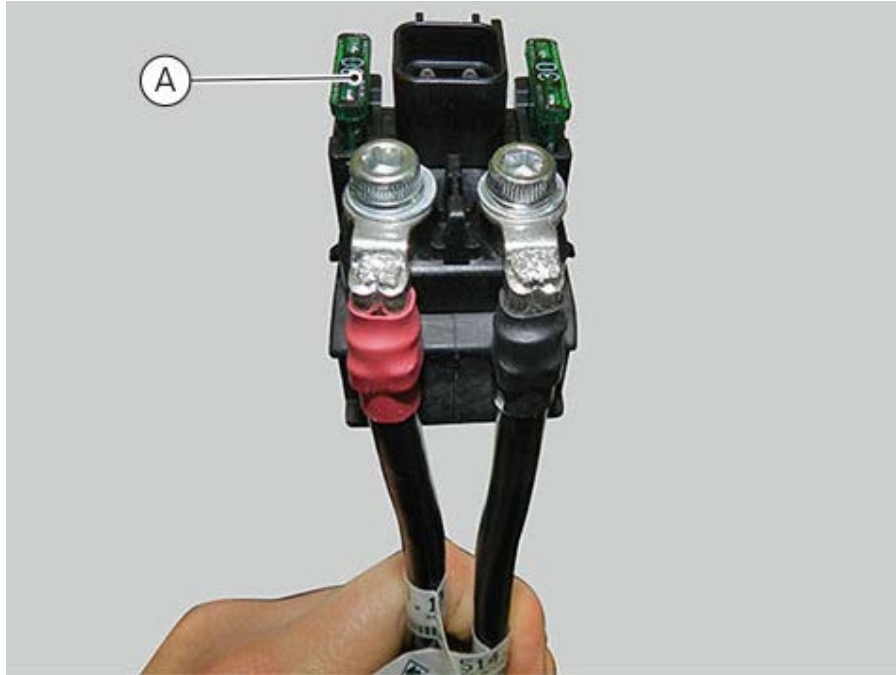
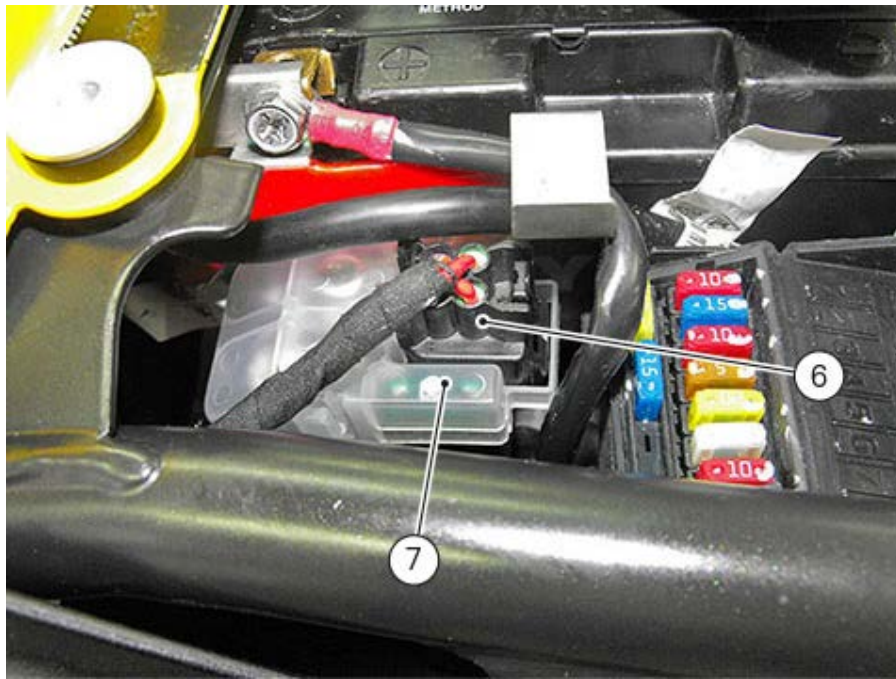

A blown fuse can be identified by breakage of the inner filament (B).

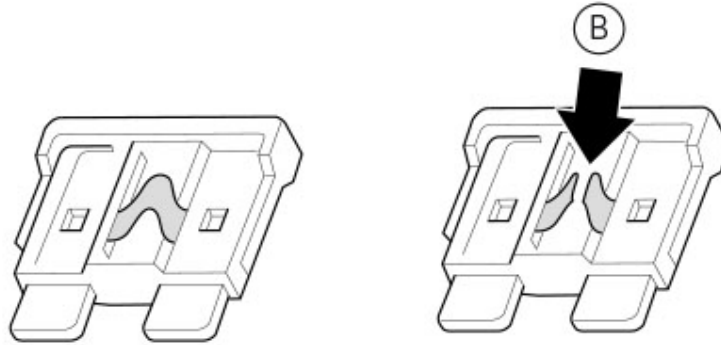

 **Important**

Switch the ignition key to OFF before replacing the fuse to avoid possible short-circuits.

 **Warning**

Never use a fuse with a rating other than the specified value. Failure to observe this rule may damage the electric system or even cause fire.

Alternator / Generator

The generator used on the Scrambler has a rated power of 490 W at 14 V and consists of a fixed element (stator/generator, A), located in the generator cover and a mobile element (rotor/flywheel, B) fastened to the crankshaft.

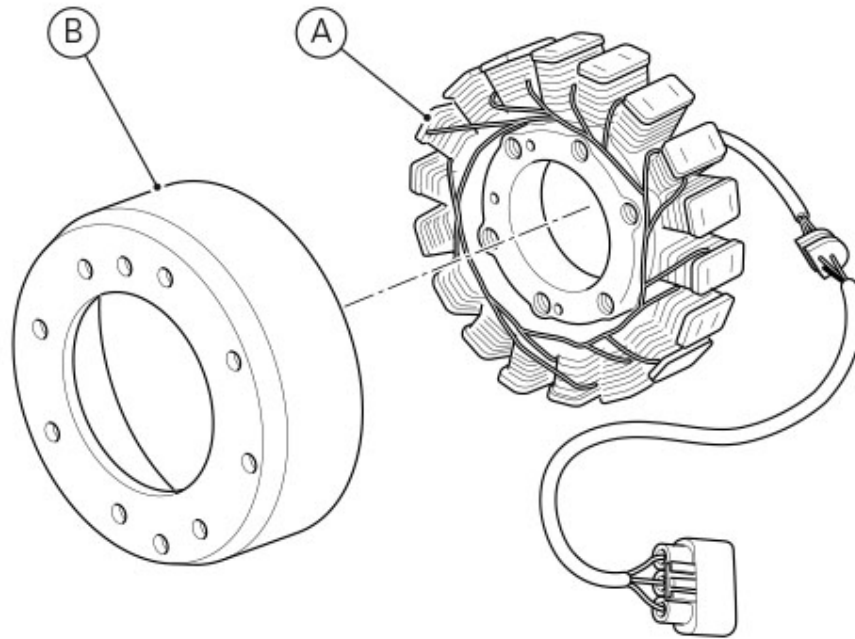

Rotor (B) is manufactured with strong permanent magnets and features a lot of pin pairs for each stator phase. This allows generating alternate voltage at a higher frequency compared to a standard generator. The result: at low rpm it is possible to generate higher current.

Important

Check the charging current by using the "DDS" diagnosis instrument.

Attention

Before testing, disconnect the generator wiring from the electrical system when the ignition key is set to OFF.

Rpm	Active voltage	Minimum voltage	Maximum voltage
1500 rpm	20.8 V	18.9 V	24.5 V
2500 rpm	34.3 V	31.4 V	40.4 V

Values significantly lower than those indicated above can be due to:

- partially demagnetised rotor;
- short-circuited windings.

In the above cases the whole generator assembly (rotor and stator) should be replaced.

If checks have a favourable outcome, reconnect the generator to the regulator with ignition key on OFF. Make sure that no cables are damaged or disconnected.

Removing the generator

For the removal procedure refer to chapter "[Removing the flywheel/generator assembly](#)".

Refitting the generator

For the refitting procedure refer to chapter "[Refitting the flywheel/generator assembly](#)".

Battery

Battery safety rules



Warning

Before carrying out any operations on the battery, keep in mind the safety standards. When under charge, batteries produce explosive gases. Keep batteries away from heat sources, sparks or open flames.

Instructions for battery use

The battery is a sealed, maintenance-free type and therefore requires no special installation procedure.



Important

Never try to open the battery as it is sealed, it does not require maintenance operations or to be filled in with acid or other types of liquids. Consequently, it does not need any operation upon its installation on the vehicle.



Note

Always keep the battery clean. Apply grease around the battery terminals to prevent corrosion.



Warning

Never remove the valve cover located on top of the cover. If the block, cover or terminals are broken or if the valve cover has been tampered with, IT IS ABSOLUTELY NECESSARY TO REPLACE THE BATTERY.



Important

If the motorcycle is left unused for more than 30 days, remove the battery and store it in a safe, cool place.



Warning

The battery gives off explosive gases; never cause sparks or allow naked flames and cigarettes near the battery. Check that during the battery charge, the area ventilation is adequate and that the ambient temperature is lower than 40 °C (104 °F). Do not try to open the battery: it does not require to be filled with acid or other types of fluids.

Always charge the battery before the first operation and after long storage periods – such as before selling the vehicle.

Removing the battery

Remove the seat ([Removing the seat](#)).

Remove belt (1) that retains battery (2). Loosen screw (3). Move cover (4) to reach the battery (2).

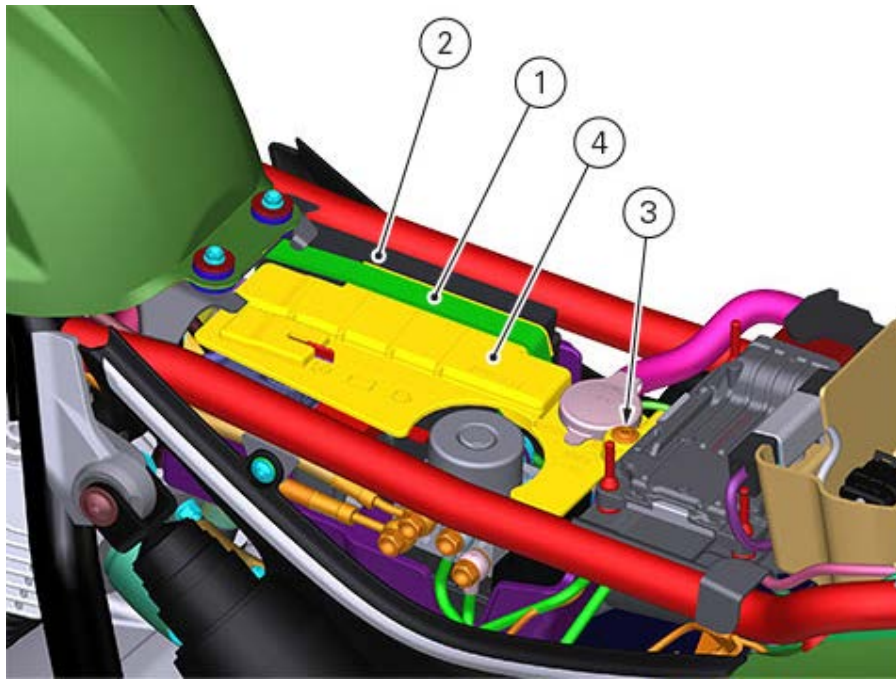

Disconnect the battery cables first from the negative pole (5) then from the positive one (6). Remove the battery (2).

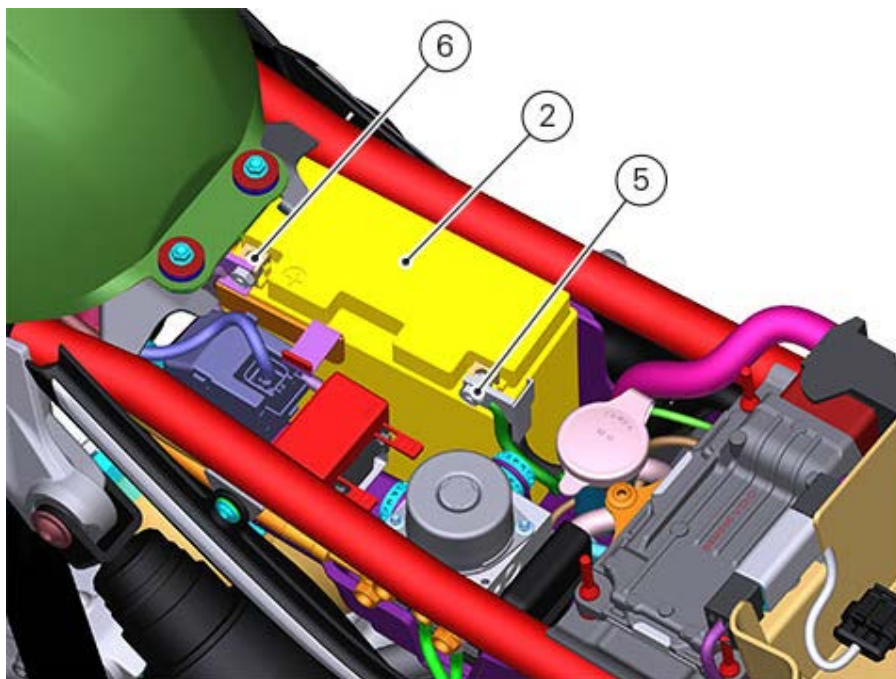

Warning

Insulate the ground cable ends you just removed to prevent them from touching the motorcycle.

Refitting the battery

Position the battery (2). Connect the positive pole by means of screw (6) by tightening it to a torque of 10 Nm \pm 10%. Tighten negative pole screw (5) to a torque of 10 Nm \pm 10%.

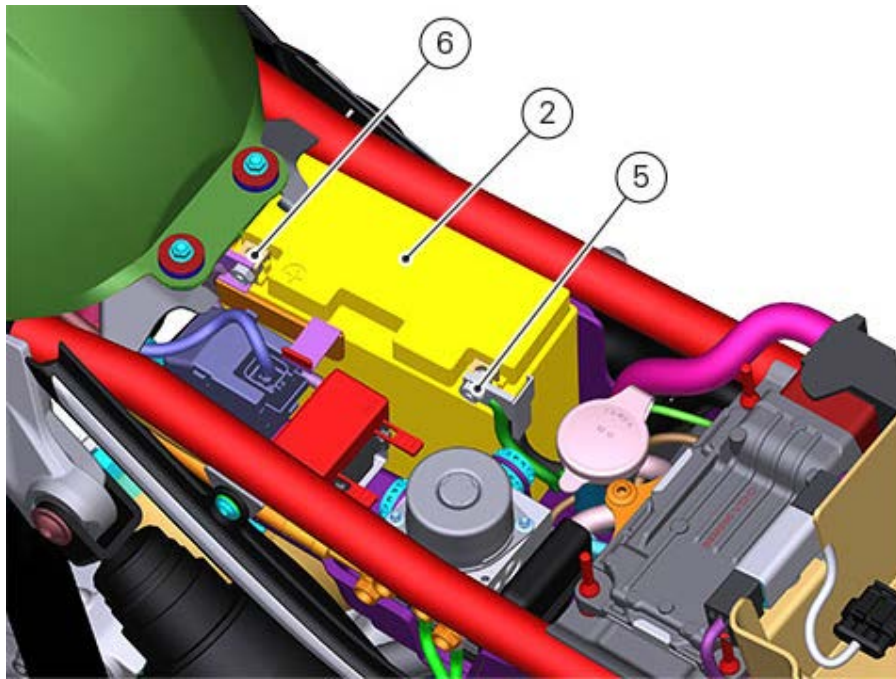

Fit cover (4) and fix it with screw (3). Fasten the battery/cover by means of belt (1).

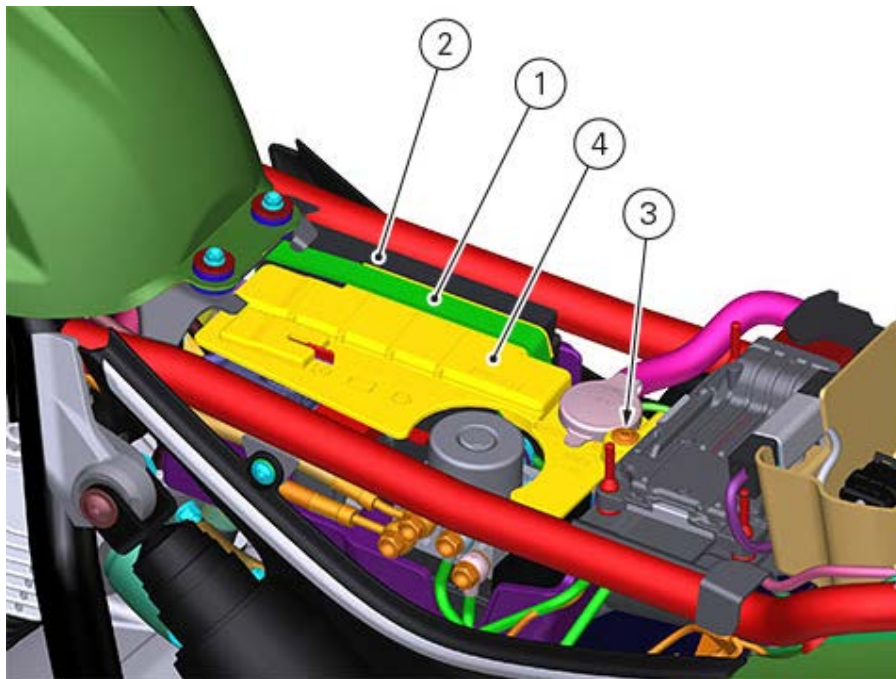

Topping up the electrolyte

Remove the battery ([Battery](#)).

Warning

Before carrying out any operations on the battery, keep in mind the safety standards (General safety rules). The electrolyte in the battery is toxic and can cause burns if it comes into contact with the skin because it contains sulphuric acid. Wear protective clothing, a face-mask and goggles when adding electrolyte. If the fluid comes into contact with the skin, wash thoroughly with fresh water. If it comes into contact with the eyes, wash thoroughly with water for 15 minutes and consult an ophthalmologist. In the event of accidental ingestion, drink large quantities of water or milk, and continue with milk of magnesia, a beaten egg or vegetable oil. Do not allow sparks, flames, cigarettes or any other heat source to get near the battery, as it produces explosive gases. When recharging or using the battery indoors, make sure that the room is adequately ventilated. Do not inhale the gases produced during recharging. KEEP OUT OF REACH OF CHILDREN.

Place the battery on a flat surface. Remove the protective film (1).

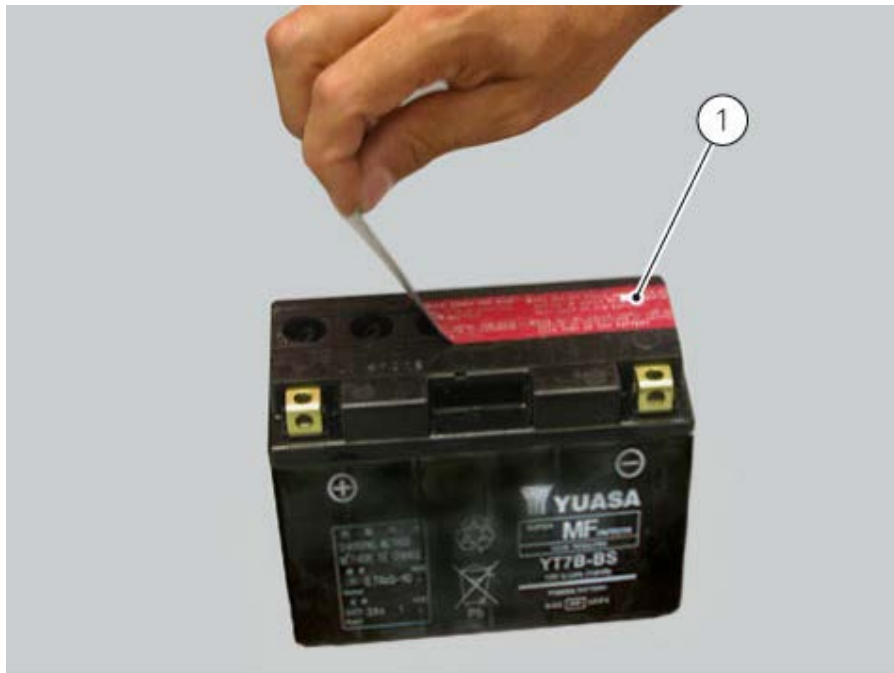

Warning

Make sure that the electrolyte is of the specific type for your battery.

Remove the container with the electrolyte from the plastic bag.

Remove the cap strip (3) from the container (2).

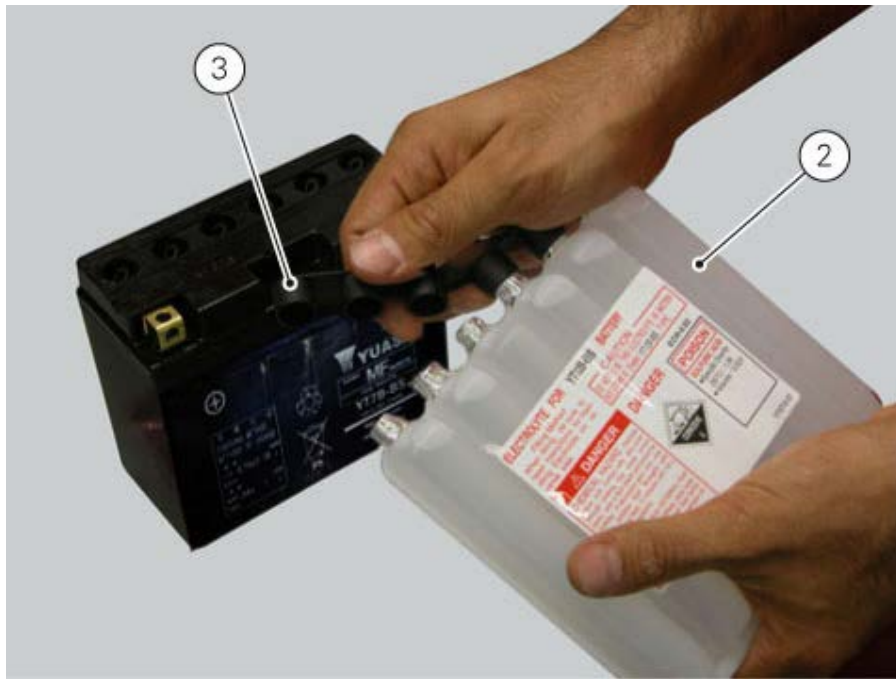

Important

Keep the cap strip (3) to hand because it will be used later to plug the battery cells.

Warning

Do not peel or perforate the sealed areas.

Place the electrolyte container (2) upside down. Align the six sealed elements with the six filler holes on the battery. Push the container (2) downwards with sufficient force to break the seals and allow the fluid to flow out.

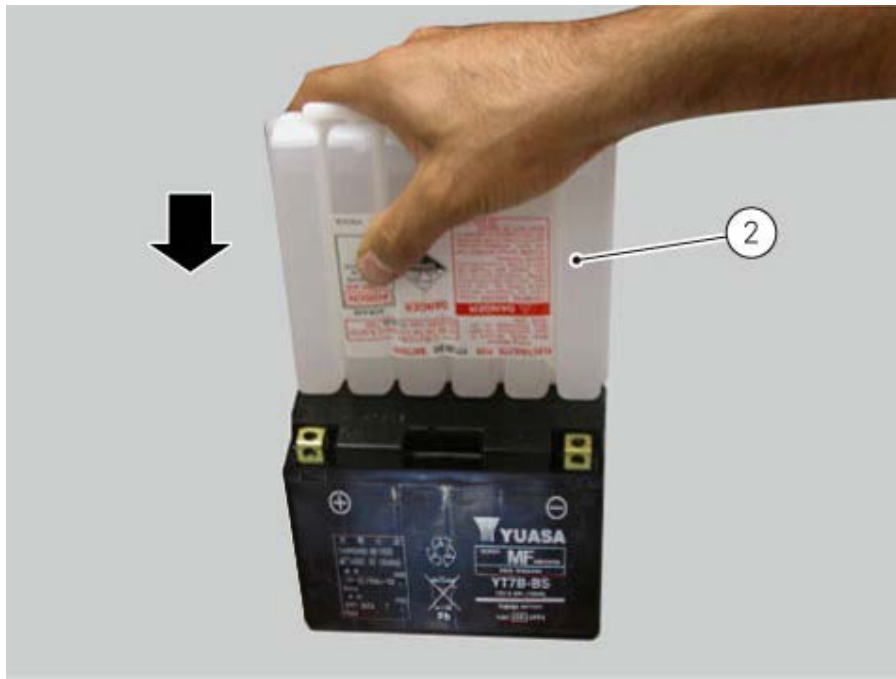

 **Note**

Do not tilt the electrolyte container as this could interrupt the flow temporarily or even permanently.

Make sure that air bubbles emerge from all six filler holes. Leave the container in this position for at least twenty minutes.

If no bubbles emerge from one of the holes, tap gently on the bottom of the respective container.



 **Important**

Never move the container away from the battery. Do not cut or puncture the container.

Make sure that all the electrolyte has flowed out. Carefully extract the container (2) from the battery. Fit the cap strip (3) previously removed from the electrolyte container (2) to the battery, and ensure the caps plug off all filler holes.

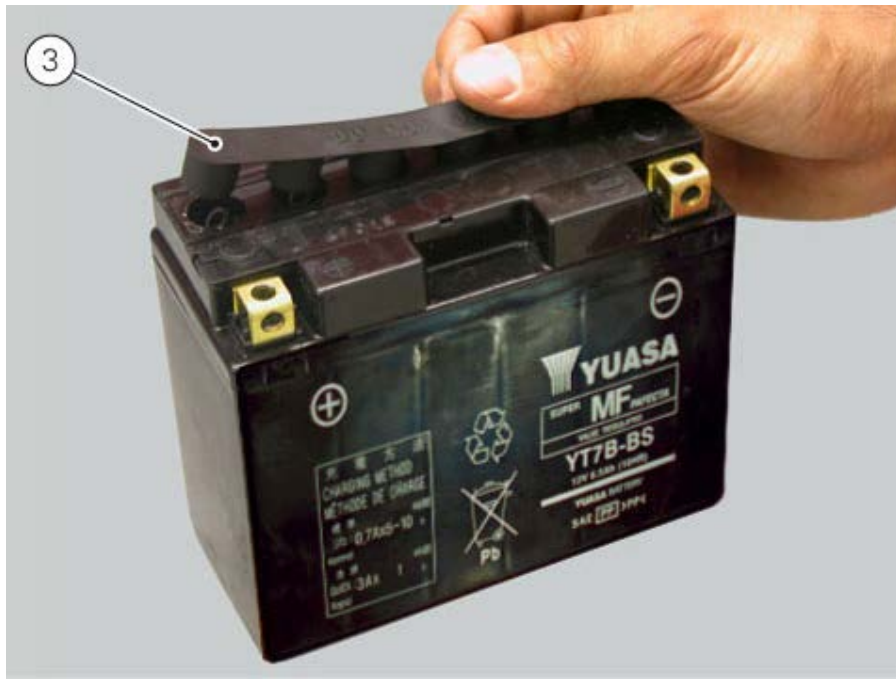

3-12 Ah batteries: leave to stand for at least 30 min.
Over 12 Ah batteries: leave to stand for at least 1 hour.
Set the cap strip on the filler holes without securing it. Recharge the battery as described in the paragraph "Recharging the battery".



Note

When using an automatic battery charger, ensure that the charger current (ampere) is equal to or higher than the value of the standard charging system (STD) indicated on the battery itself.

Press firmly downwards with both hands until the caps are firmly in place (do not use a hammer).

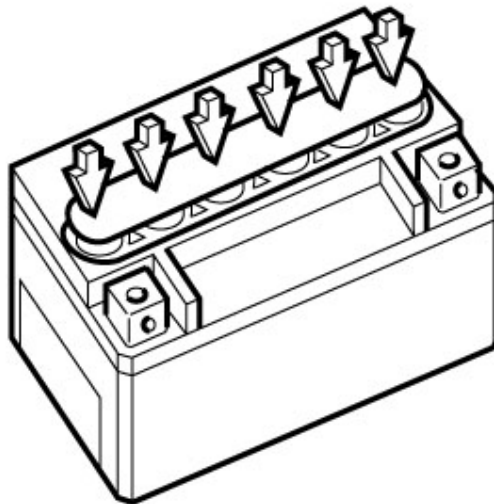

Recharging the battery

Refer to the label on the battery showing the inspection intervals in order to determine when to test the voltage.



Charge the battery if the open circuit voltage is lower than 12.8 V. Leaving the battery discharged for more than one month could damage it. Check the battery charge with a voltmeter. Always check the condition of the battery before recharging and 1 to 2 hours afterwards.

Warning

Pay careful attention to recharging times. Stop charging immediately if the battery becomes too hot to the touch. Leave to cool before resuming charging.

Use only constant-voltage battery chargers.
Check that battery terminals are properly connected to the battery charger.
To charge the battery, proceed as follows.

Type of charging	Volt	Ampere (A)	Time (Hours)
Normal	12	1.2	5-10

Use fast charging in emergencies only.

Storing the battery

If the battery voltage is less than or equal to 11.5V, it must be recharged.

Connect the battery charger to the battery.

Use a voltage of 16-17V.

If the ammeter shows no change, increase the voltage to maximum 25V.

Charge for 5 minutes.

If the ammeter shows a change, restore a voltage of 16-17V; otherwise replace the battery.

Checking the battery charging system

Perform checks on the system as indicated in the following paragraphs:

[Recharging the battery](#)

[Topping up the electrolyte](#)

[Battery](#)

[Alternator](#)

[Rectifier-regulator](#)

Solenoid starter

The solenoid starter (1) is located under the seat, inside the electrical components compartment.

Remove the seat ([Removing the seat](#)).

Disconnect the battery ([Battery](#)).

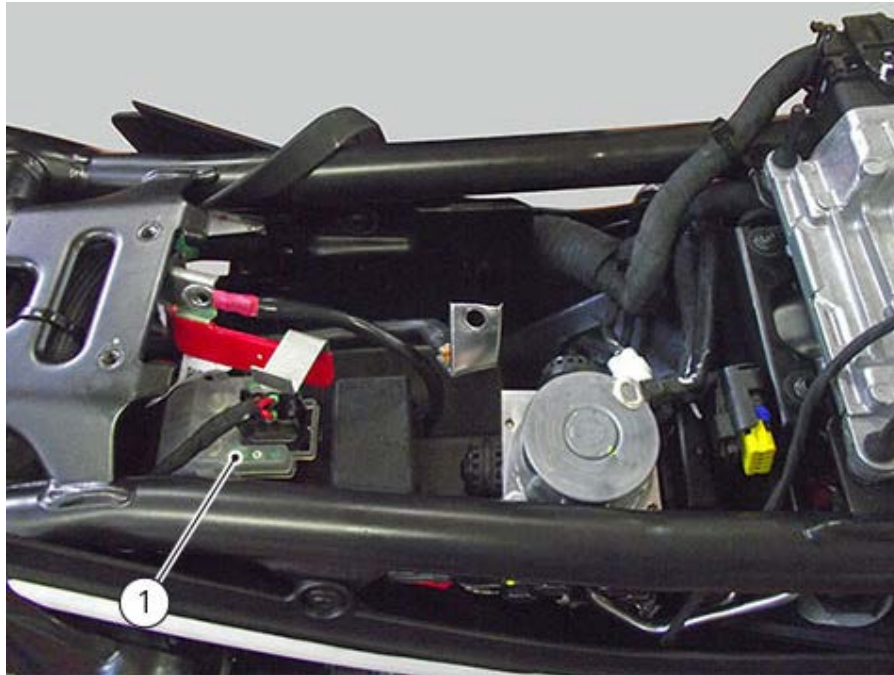

Removal procedure

Disconnect solenoid starter connector (2) from the wiring. Slide the solenoid starter out of its seat. Remove protection (3).



Undo the screws (4), taking care to collect the spring washers (5).

Remove the starter motor-solenoid starter cable (6) and the solenoid starter-battery cable (7).

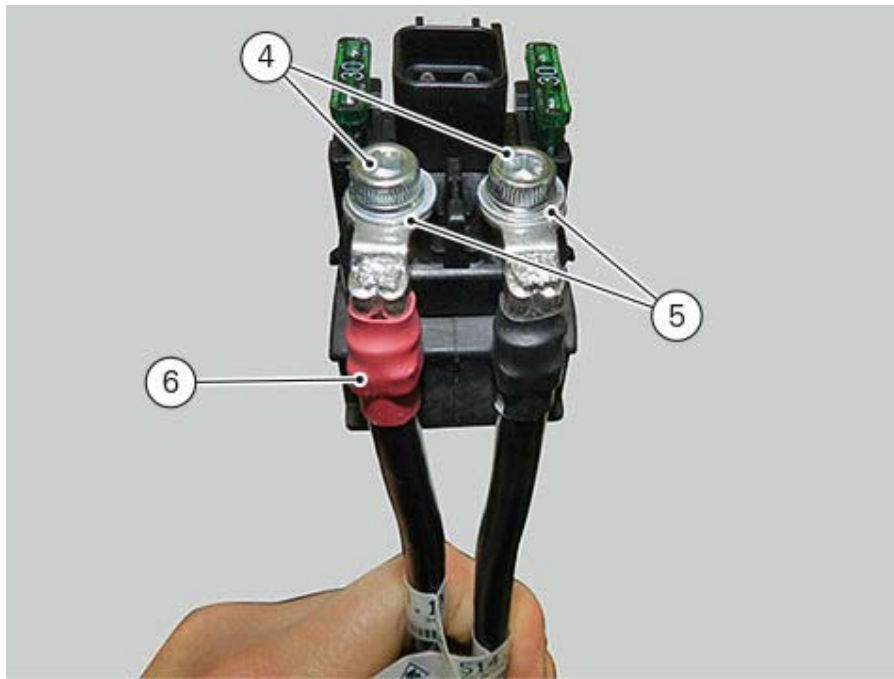

Checking operation of the solenoid starter.

Apply 12 V (battery voltage) across the positive terminal and negative terminal of the connector. With a multimeter connected between the two poles (threaded pins) of the solenoid starter, check for electric continuity. If there is no electric continuity, ensure that the terminals are not oxidised and apply water repellent spray. Change the solenoid starter if the malfunction persists.

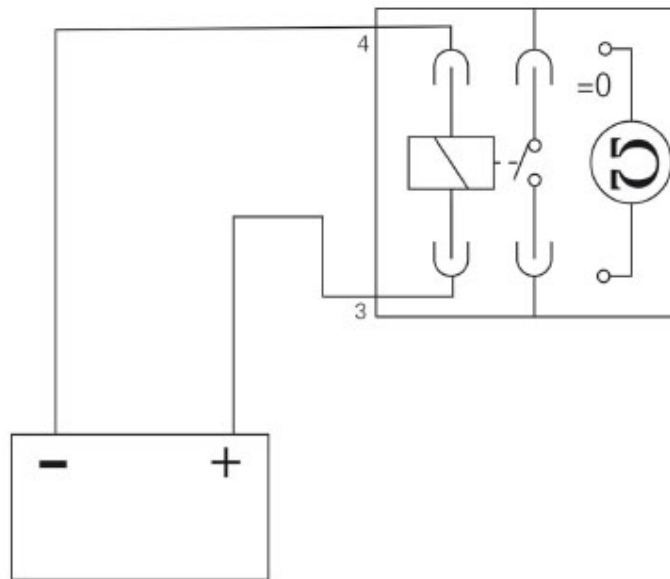

Refitting procedure

Lay down the starter motor-solenoid starter cable (6) and the solenoid starter-battery cable (7). Start screws (4) with washers (5). Tighten screws (4) to the specified torque of 10 Nm \pm 10%. Refit protection cover (3). Fasten solenoid starter in its seat and connect the connector.

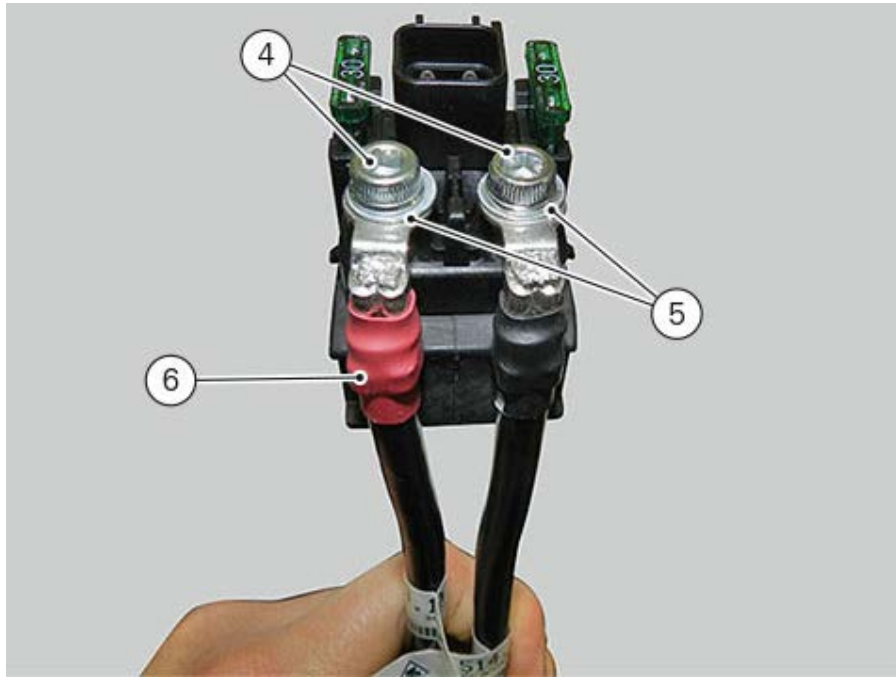

Refit the seat ([Refitting the seat](#)).

Starter motor

Electric features:
12 V / 0.7 kW



The starter motor is highly compact and reliable, therefore rarely raises any operating issue.

In case of faults:

- ensure that the starter motor wiring terminal is properly tightened under the nut and shows no sign of oxidation;
- if the terminal is properly tightened and free from oxidation, remove the starter motor and test it under no-load conditions (no load applied to the shaft).

Warning

Secure the starter motor to a test bench, making sure not to damage the casing.

Warning

Use a fully charged 12 V battery for the test.

- Use battery-motor connection cables which are no longer than 70 cm and with the same cross-section as the cable on the vehicle itself;
- connect the negative terminal of the battery to an unpainted area of the starter motor casing and the positive terminal to its electrical terminal;
- the shaft of the starter motor should rotate freely and at a high speed.

Warning

Take care not to short-circuit the two cables connected to the battery.

Electric starting system

The electric starting system consists of a solenoid starter (1) and a starter motor.

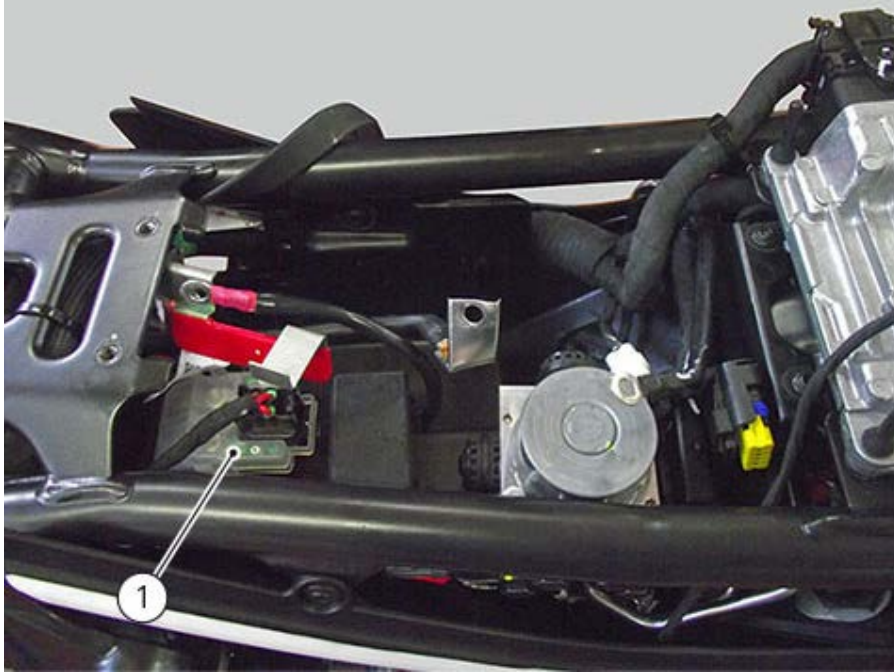

Aligning the headlight

Position the vehicle with tyres inflated at the indicated pressure ("Front wheel" and "Rear wheel") and a person seating on the seat, perfectly perpendicular to his/her longitudinal axis.
Position the vehicle 10 metres from a wall or a screen.

On the wall or surface, draw a horizontal line at the same height from the ground as the centre of the headlight and a vertical line aligned with the longitudinal axis of the motorcycle.



Note

If possible, perform this check in dim light.

Switch on the low beam. The height of the upper limit between the dark area and the lit area must not be more than $\frac{9}{10}$ of the height from the ground of the headlight centre.



Note

This is the procedure specified by Italian regulations for checking the maximum height of the light beam. Please adapt said procedure to the provisions in force in your own country.

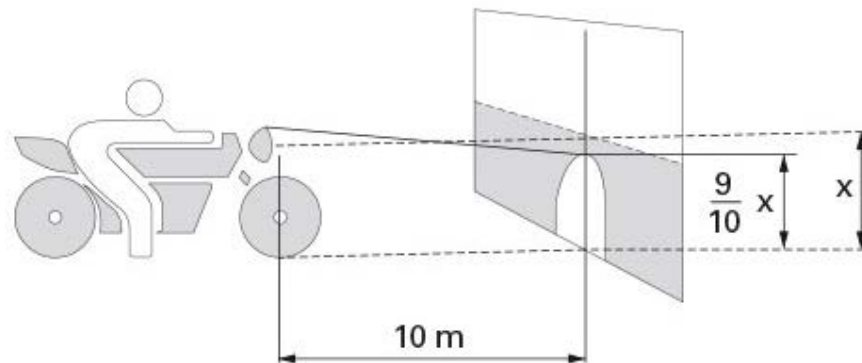

The vertical alignment of the headlight can be manually set by means of screw (2).
Turn clockwise to raise the beam, counter clockwise to lower it.

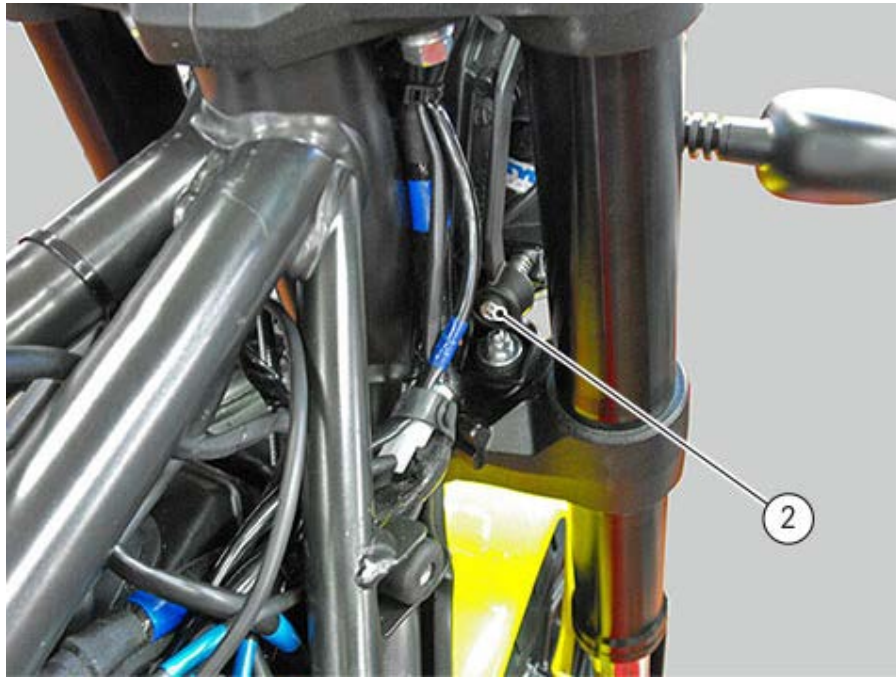

Replacing the light bulbs — Headlight

Removing the light assembly

Remove retainer (1) and the headlight regulation screw (2).
Loosen screw (2) on the opposite side.

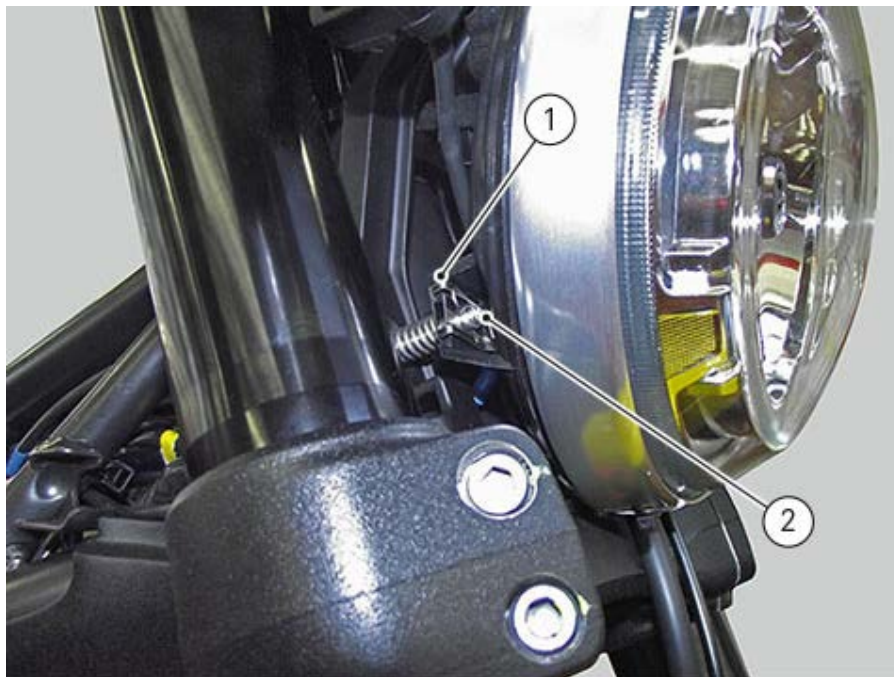

Remove screws (3) that retain U-bolts (4) of headlight (5).

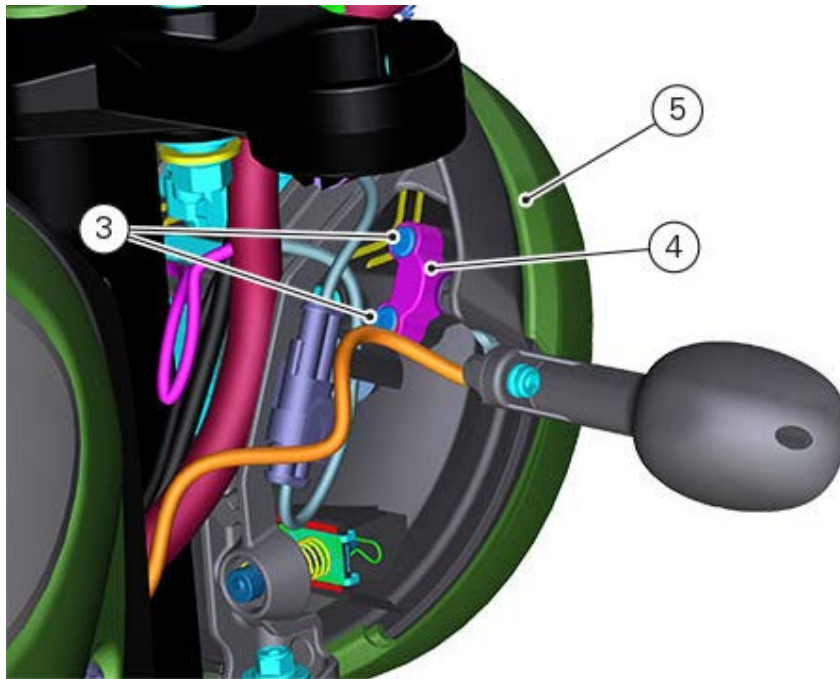
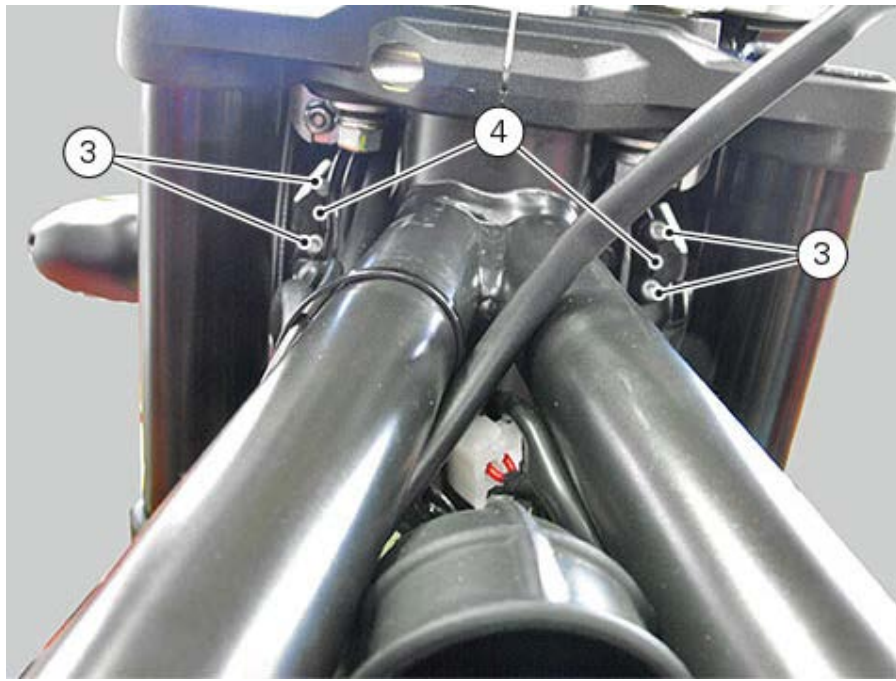

Remove headlight (5) and disconnect connector (6).

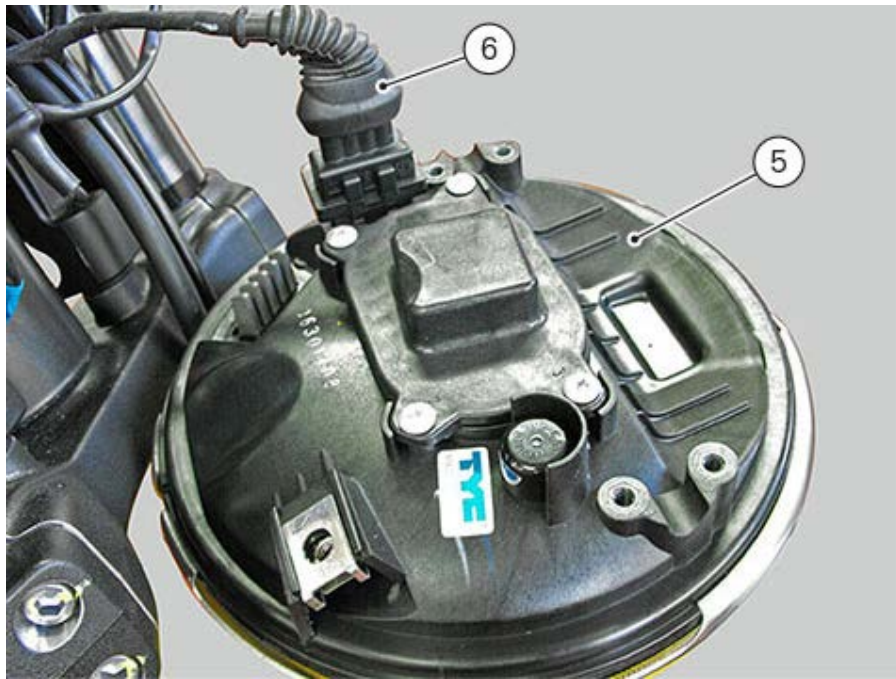

Refitting the light assembly

Connect connector (6) to headlight (5).



Fit headlight (5) by matching seats (A) with the two pins (6) on the headlight support subframe (7).

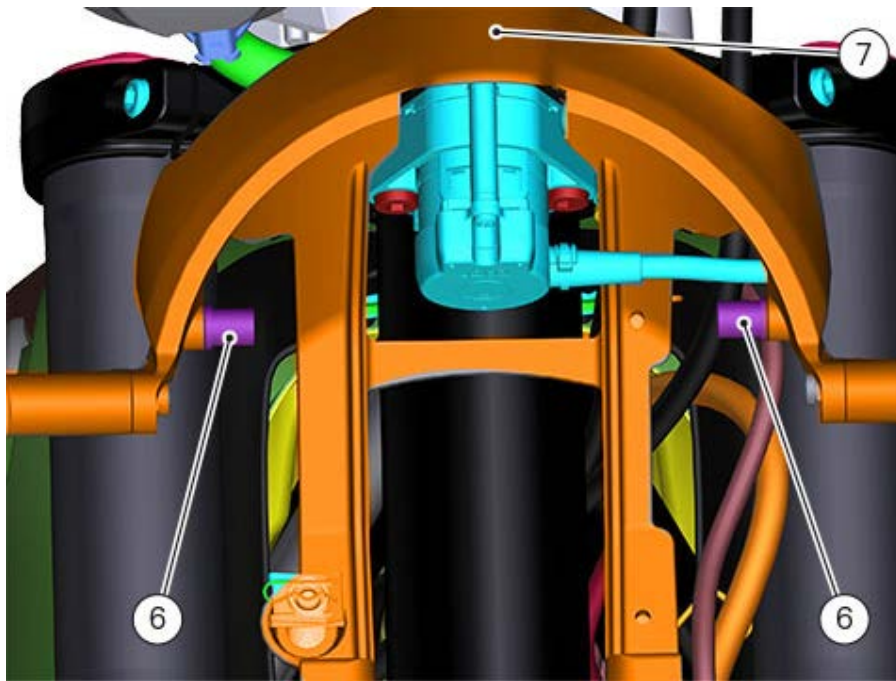
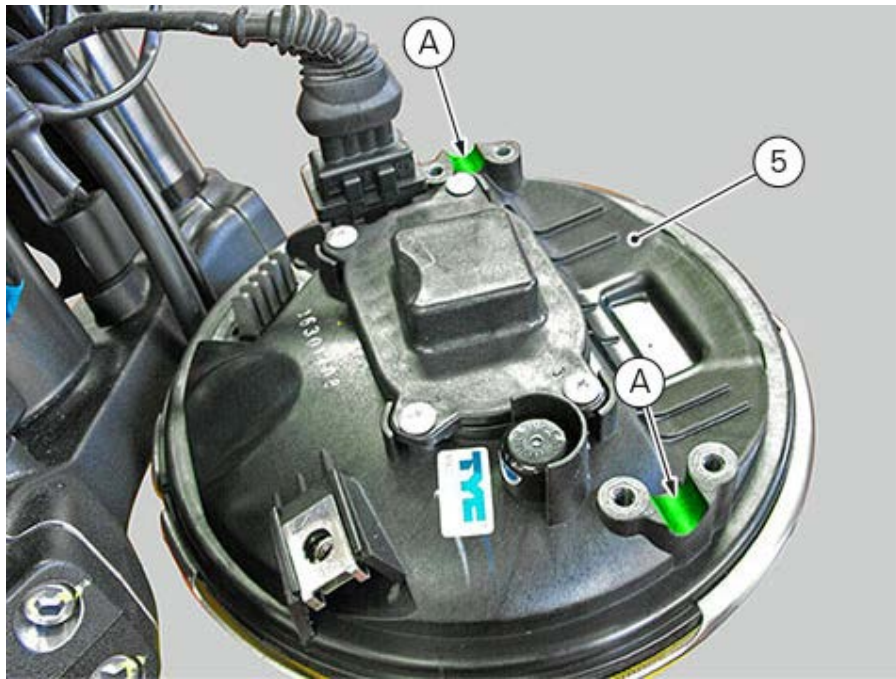

Fix the U-bolts (4) by tightening screws (3) to a torque of $5 \text{ Nm} \pm 10\%$.

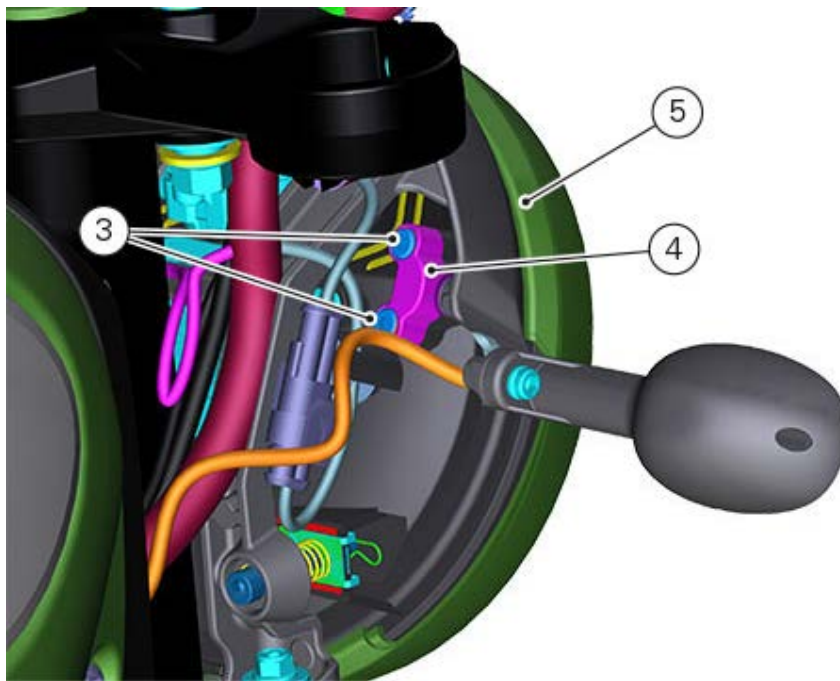

Screw the headlight regulation screw (2) until reaching the correct orientation. Then, insert the safety retainer (1).

CHANGING BULBS

To remove the bulb, remove the headlight from the frame ([Replacing the headlight](#)).

Remove retaining screws (1) of the bulb cover (2).

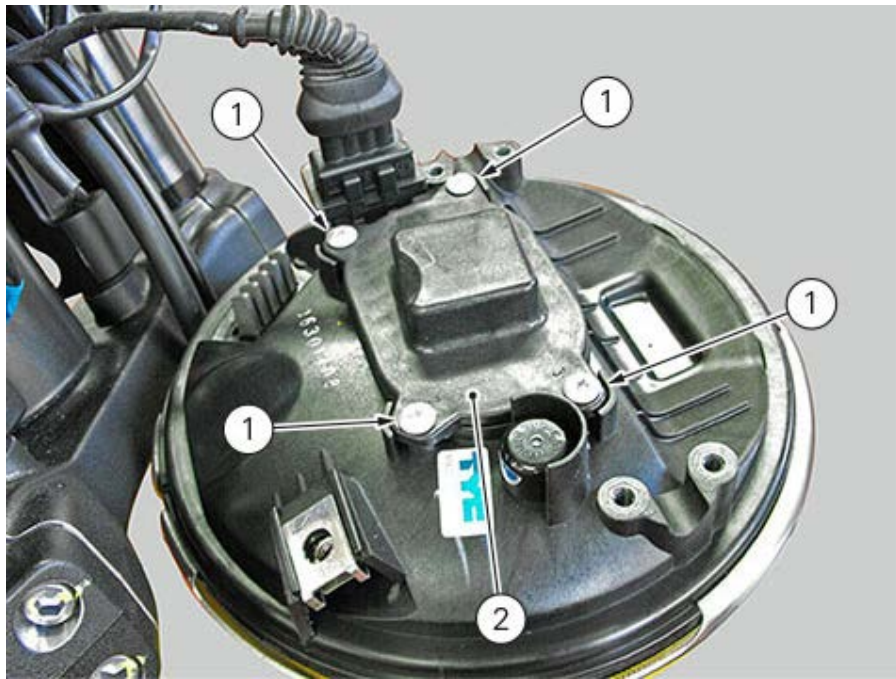

Remove bulb (3) by releasing spring (4).

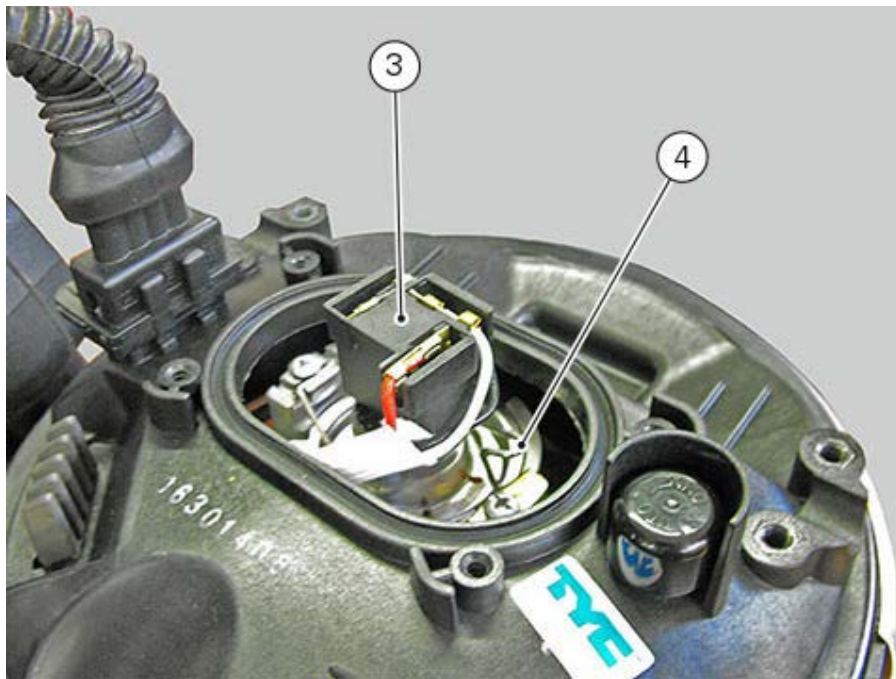

Entering PIN CODE function for overriding purposes

In case of key acknowledgement system or key malfunction, the instrument panel allows the user to enter his/her own PIN CODE to temporarily restore motorcycle operation.

If upon key-on an Immobilizer ERROR occurs, the instrument panel automatically activates in MENU 1 the possibility to enter the four-digit PIN CODE previously memorised with the relevant function in the Setting Menu, PIN page.

Entering the code (A):

- 1 Press button (2) or (1), only one digit indicating "0" starts flashing;
- 2 Each time you press button (2) the displayed number increases by one (+ 1) up to "9" and then starts back from "0";
- 3 Each time you press the button (1) the displayed number decreases by one (- 1) up to "1" and then starts back from "0";
- 4 To confirm the number, press the button (4);

Repeat the procedures until you confirm all the digits of the PIN CODE.

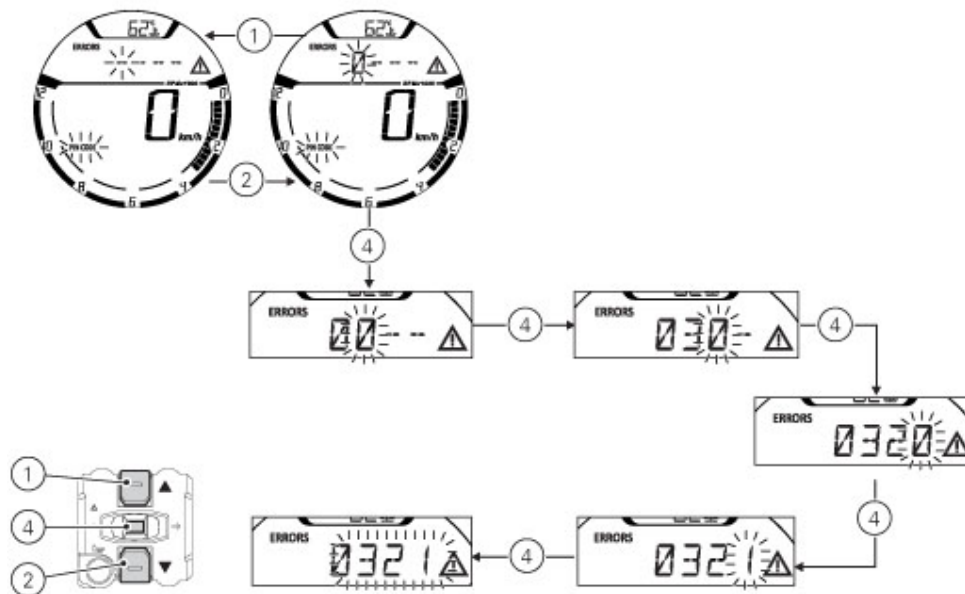

When you press button (4) to confirm the fourth and last digit:

- if the PIN code (A) is correct, the instrument panel shows the message OK for 2 seconds followed by the "standard screen" and enables the vehicle to start (C);
- if the PIN code (B) is not correct, the instrument panel displays WRONG for 2 seconds and then highlights the string of four dashes "- - - -" to allow you to try again. The number of possible attempts is unlimited and determined by a preset time-out of 2 minutes (D). After 2 minutes, the instrument panel shows the standard screen and does not allow the vehicle to start (E).

Important

If this procedure is necessary in order to start the motorcycle, contact an Authorised Ducati Service Centre as soon as possible to fix the problem.

Note

The vehicle can be started until a Key-Off is performed. If the problem still persists upon the next starting attempt, repeat the procedure from the beginning in order to start the motorcycle temporarily again.

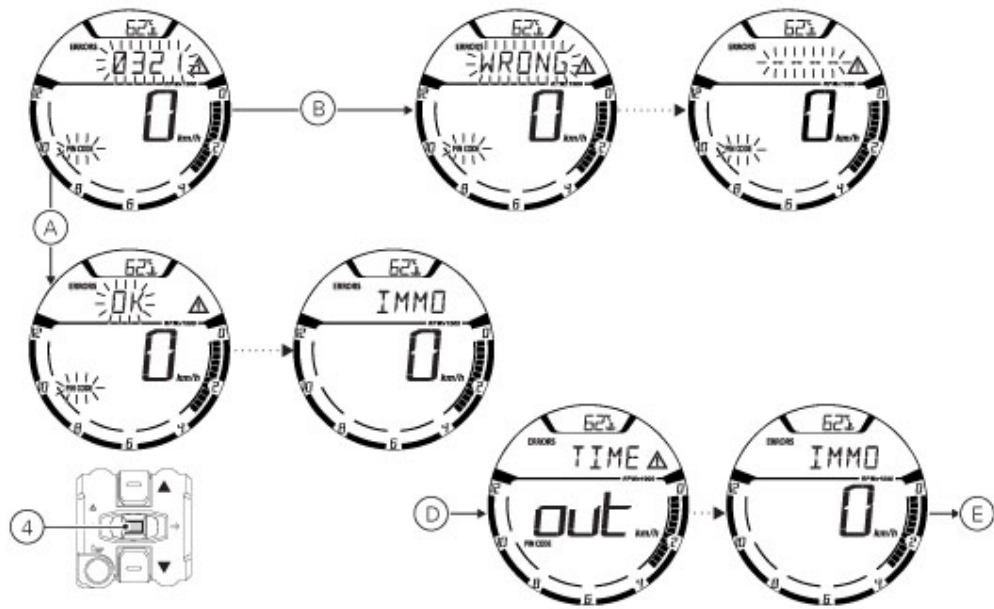

Key duplication

When a customer needs spare keys, he/she shall contact a Ducati authorised service centre and bring all keys he/she still has.

The Ducati authorised service centre will program all new and old keys.

The Ducati authorised service centre may ask to the customer to prove to be the motorcycle owner.

The codes of the keys missing during the programming procedure will be erased to ensure that any lost key can not start the engine.



Note

If the motorcycle owner changes, it is necessary that the new owner is given all keys.

Operation

Every time you turn the key from ON to OFF, the protection system activates the engine block. If also in this case you are not able to start the engine, contact an authorised Ducati service centre.



Warning

Strong impacts could damage the electronic components inside the key. During the procedure always use the same key. Using different keys may prevent the system from acknowledging the code of the inserted key.

Keys

The motorcycle comes with 2 keys.
They contain the "Immobilizer system code".
Keys (B) are those for the standard use, i.e. to:

- start the engine;
- open the fuel tank plug;
- open the seat lock.



Warning

Separate the keys and use only one of the two to ride the bike.

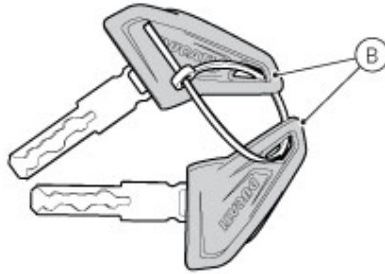

Immobilizer system

To increase protection against theft, motorcycle features an electronic engine locking system (IMMOBILIZER) which is automatically enabled upon every Key-Off. Inside of each key handgrip there is an electronic device that modulates the signal sent by a special antenna integrated in the ignition switch upon starting. Such modulated signal represents the "password", that changes upon every starting, that allows the control unit to acknowledge the key and thus starting the engine.

Activations through diagnosis instrument

The DUCATI diagnosis instrument allows performing a series of activations to check some instrument panel functions and resetting parameters or warning lights.

After each activation, the instrument panel will restore its standard functions.



Note

The activations must be performed only with key turned to ON, engine off and battery voltage ≥ 11.0 V.

Immobilizer (keys) reset

This activation allows "erasing" the "keys" to reprogramme the Immobilizer System. Upon receiving this request, the instrument panel resets the previously stored keys. Upon next Key-On, the Immobilizer System will be "virgin" and it will be possible to reprogramme new keys.

Programming the Immobilizer System

When replacing the instrument panel with a new one or when reprogramming the Immobilizer System (because one or both keys got lost).

If the System is "virgin", upon Key-On the instrument panel immediately activates the "Immobilizer Programming" mode.

Programming procedure:

- insert KEY 1 (one of the two black keys) and turn the key from Off to On;
- within 3 seconds turn the key from On to Off;
- within 15 seconds insert KEY 2 (the other black key) and turn the key from Off to On;
- within 3 seconds turn the key from On to Off;
- within 15 seconds insert KEY X again (no matter if Key 1 or Key 2) and turn the key from Off to On.
- If the procedure was successful the instrument panel shows "PROG." and "OK" for 3 seconds and then switches to the standard display mode.

Light control

Low / High beam

This function allows you to reduce current consumption from the battery, by managing headlight switching-on and off.

Upon Key-On, low and high beams remain off (OFF).

By starting the engine, the low beam will be automatically activated; from now on, the "standard" operation will become active, i.e. it will be possible to switch from low to high beam by pressing button (3) in position (V) or use the "FLASH" function by pressing button (3) in position (O). If engine is not started upon key-on, it is anyway possible to switch the lights on by pushing the button on the LH high/low beam switch: button (3) in position (V).

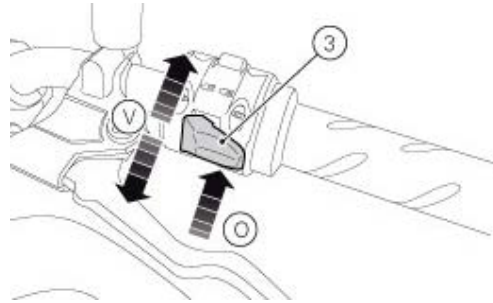

The low beam lights are turned on the first time it is pressed; from this moment, the same button can be used to switch on (and off) the high beam light: if the engine is not started within 60 seconds, the low beam and high beam that were turned on will turn off. If the headlight was turned on before starting the engine with the procedure described above, the headlight will turn off automatically when starting the vehicle and will turn ON again when the engine has been completely started.

Turn indicators

Turn indicators are automatically controlled by the instrument panel.

After activating one of the two turn indicators, user can disable them using button (see Fig 1) 3, on the left switch.

If the turn indicator is not reset manually, the instrument panel will automatically switch it off after the motorcycle has travelled 500 m (0.3 miles) from when the turn indicator was activated. The counter for the distance travelled for automatic deactivation is only activated at speeds below 80 km/h (50 mph).

If the calculation of the distance for automatic deactivation is activated and then the motorcycle exceeds a speed of 80 km/h (50 mph), the calculation will be interrupted and will restart when the speed returns below the indicated threshold.

Hazard function

The "Hazard" function turns all four turn indicators on at the same time to signal an emergency condition.

The "Hazard" function is activated by taking button (3) to position (6) for 3 seconds. Activation is only possible when motorcycle is ON (i.e. when key is turned to "ON" while engine status does not matter).

When the "Hazard" function is active, all four turn indicators blink at the same time as well as warning lights (7) on the instrument panel. The "Hazard" function can be disabled both with motorcycle on (key set to "ON") - by taking button (3) to position (6) or by taking button (3) to its central position - and with motorcycle off (key set to OFF) by taking button (3) to position (6).



After activating the "Hazard" function, if motorcycle is switched OFF (key set to OFF), the function will stay active until manually disabled by user or it will be automatically disabled after 120 minutes (2 hours) to save battery charge.

Setting the units of measurement

This function allows changing the units of measurement of the displayed values. To manually set the units of measurement, you must enter the SETTING MENU.

Select UNITS option, by pressing button (1) or (2). Once function is highlighted, press CONFIRM MENU button (4).

When entering this function, use buttons (1) and (2) to select the parameter for which you want to set a new unit of measurement or to restore the default settings:

- SPEED;
- temperature (TEMP.);
- restore the default settings for units of measurement (UNIT:DF).

To exit the menu and go back to the previous page, select "EXIT" and press button (4).

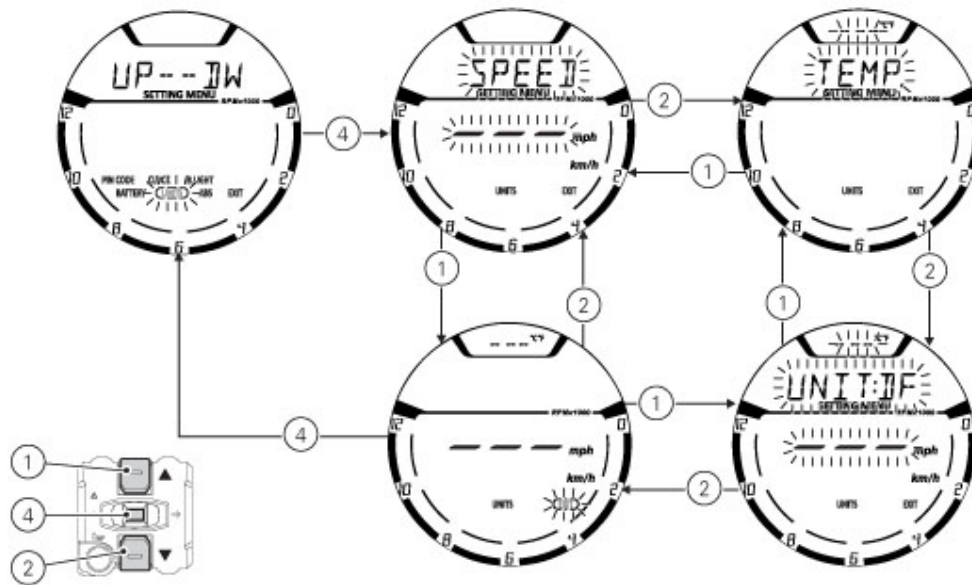

Setting the units of measurement: Speed

This function allows changing the unit of measurement of Vehicle speed, Odometer, Trip 1, Trip 2 and Trip Fuel (when active). To gain access to this function enter the SETTING MENU, use buttons (1) and (2) to select UNITS and press button (4). Select SPEED option, by pressing button (1) or (2).

Once SPEED function is highlighted, press CONFIRM MENU button (4). When entering the function, units of measurement (mph, km/h) are indicated: current unit of measurement is flashing while the other available unit is not flashing. Press buttons (1) and (2) to highlight the units of measurement one by one: in particular, use button (1) to highlight the following item and button (2) to highlight the previous item. Select the required unit of measurement and then press the CONFIRM MENU button (4) to confirm the selected unit; then the selected unit of measurement is saved in the instrument panel and the SPEED indication starts flashing again.

Press button (2) to make the EXIT box flash; press button (4) to quit and go back to the previous window.

- Km/h: if this unit is set, the following values will have the same units of measurement:
 - TOT, TRIP 1, TRIP 2, TRIP FUEL: Km
 - Motorcycle speed: Km/h
- mph: if this unit is set, the following values will have the same units of measurement:
 - TOT, TRIP 1, TRIP 2, TRIP FUEL: miles
 - Motorcycle speed: mph

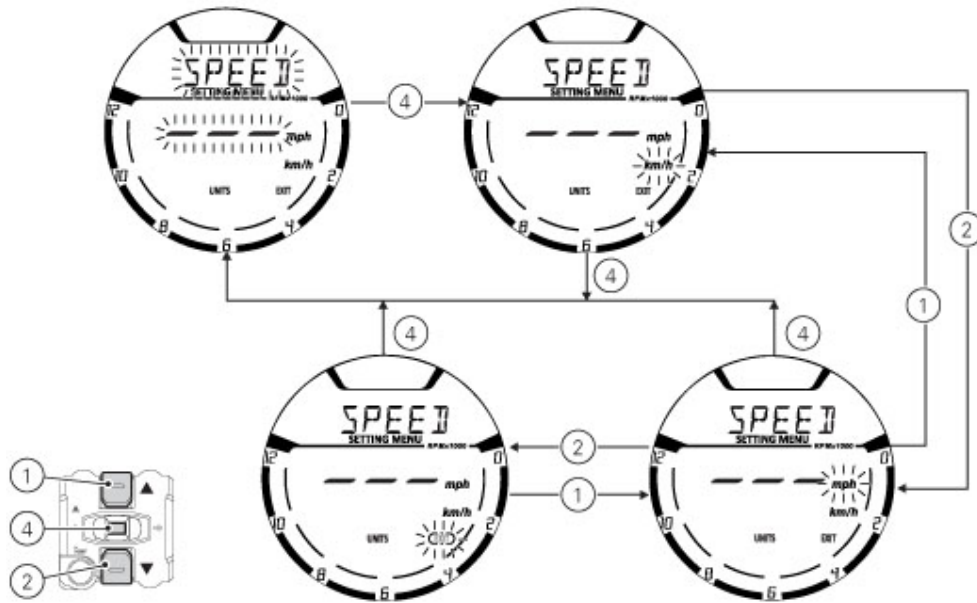

Setting the units of measurement: Temperature

This function allows you to change the units of measurement of the Air Temperature indications. To gain access to this function enter the SETTING MENU, use buttons (1) and (2) to select UNITS and press button (4).

Select TEMP. option, by pressing button (1) or (2).

Once TEMP. function is highlighted, press CONFIRM MENU button (4).

When entering the function, units of measurement (°C, °F) are indicated: current unit of measurement is flashing while the other available unit is not flashing.

Press buttons (1) and (2) to highlight the units of measurement one by one: in particular, use button (1) to highlight the following item and button (2) to highlight the previous item. Select the required unit of measurement and then press the CONFIRM MENU button (4) to confirm the selected unit; then the selected unit of measurement is saved in the instrument panel and the "TEMP." indication starts flashing again.

Press button (2) to make the EXIT box flash; press button (4) to quit and go back to the previous window.

- °C: if this unit is set, the following values will have the same units of measurement:
 - T – AIR: °C
- °F: if this unit is set, the following values will have the same units of measurement:
 - T – AIR: °F

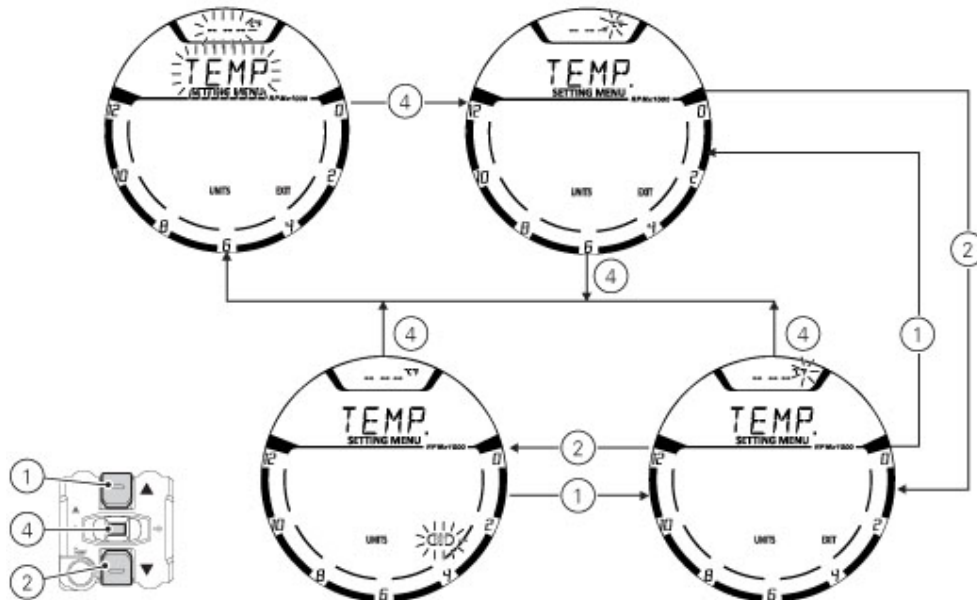

DEFAULT setting

This function allows setting the DEFAULT units of measurement according to the vehicle version.

To gain access to this function enter the SETTING MENU, use buttons (1) and (2) to select UNITS and press button (4). Press button (1) or (2) to make the "UNIT:DF" option start flashing and then press button (4) for 3 seconds.

After 3 seconds the instrument panel shows "WAIT" for 2 seconds; then the "DF-OK" message indicates that the units of measurement have been restored.

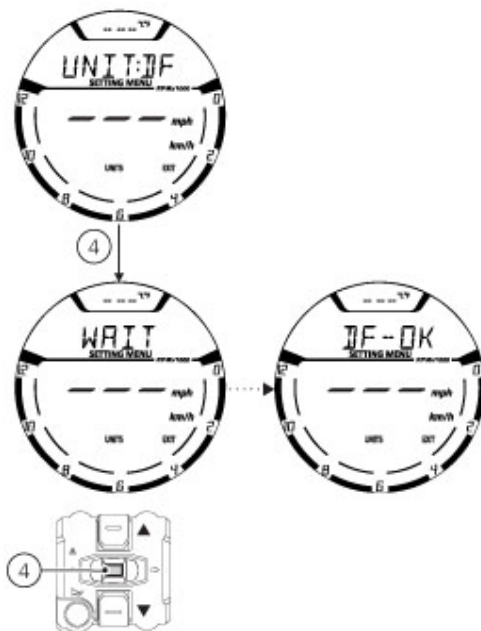

Changing the PIN CODE

To change the existing PIN CODE and activate a new one, you must open the SETTING MENU. Select PIN CODE option, by pressing button (1) or (2). Once function is highlighted, press CONFIRM MENU button (4).

Note

If upon accessing this function, the "N : " (New) and four flashing dashes "- - - -" are shown, it means that the PIN CODE has never been activated and it is necessary to do it.

When accessing the function, the display will show "O : " (old) followed by four flashing dashes "- - - -".

Note

To change the PIN CODE, you must know the already stored PIN.

To go back to the previous indication without modifying the PIN CODE, press button (2); as soon as the "EXIT" box starts flashing, press button (4) again.

Entering the "old" code:

- 1 Press button (4), only one digit indicating "0" starts flashing;
- 2 Each time you press button (2) the displayed number increases by one (+ 1) up to "9" and then starts back from "0";
- 3 Each time you press the button (1) the displayed number decreases by one (- 1) up to "1" and then starts back from "0";
- 4 To confirm the number, press the button (4);

Repeat the procedures until you confirm all the digits of the PIN CODE.

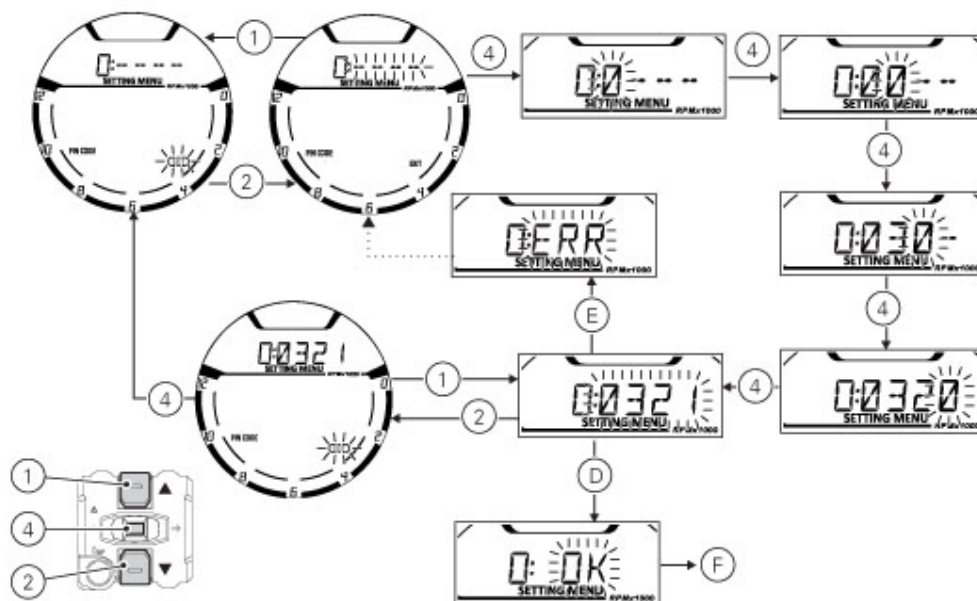

After pressing button (4) to confirm the fourth and last figure, the 4-digit code starts flashing. Press button (4) to check the entered PIN CODE. After you press the button:

- if the PIN CODE is correct (D), the instrument panel shows "OK" flashing for 3 seconds, followed by "N: " (new) and four flashing dashes "- - - -" relevant to the new PIN CODE (F);
- if the PIN CODE is not correct (E), the instrument panel shows ERR. flashing for 3 seconds, followed by "O: " (old) and four flashing dashes "- - - -" to enter the PIN again. .

Repeat the procedures until you confirm all the digits of the PIN CODE.

Entering the "new" code:

- 1 Press button (4), only one digit indicating "0" starts flashing;
- 2 Each time you press button (2) the displayed number increases by one (+ 1) up to "9" and then starts back from "0";

- 3 Each time you press the button (1) the displayed number decreases by one (- 1) up to "1" and then starts back from "0";
- 4 To confirm the number, press the button (4);

Repeat the procedures until you confirm all the digits of the PIN CODE.

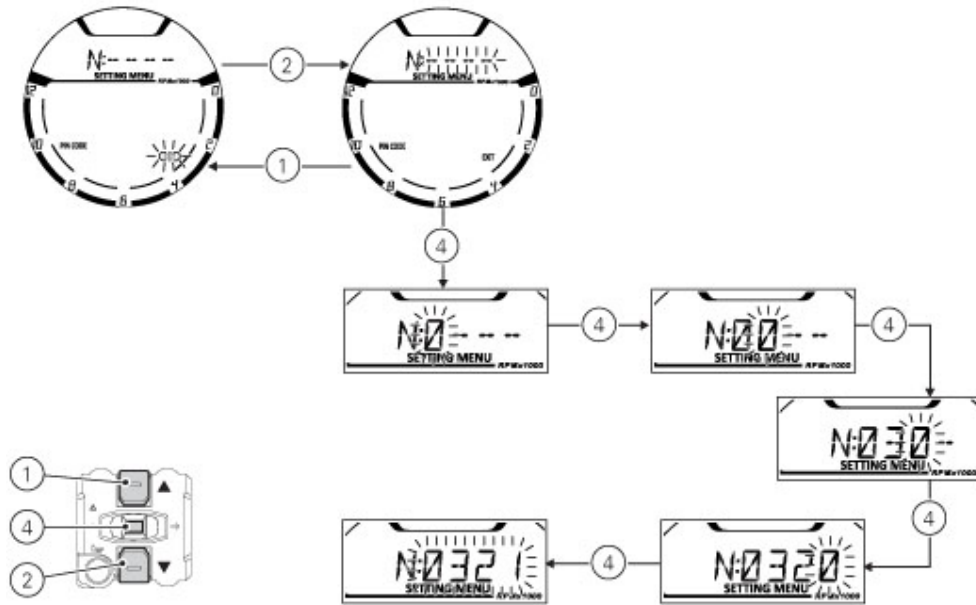

Press button (4) to confirm the fourth and last figure: the 4-digit code starts flashing.

To memorise the new setting, keep button (4) pressed for 3 seconds.

If new settings have been saved (D), "MEM" will be shown, the "EXIT" option will be highlighted and its box will be flashing.

To quit, press button (4).

If settings have not been saved, the instrument panel will highlight again the string of four dashes "- - - -" of the new PIN to allow the rider to try again and enter a new code.

Note

You can change your PIN CODE an unlimited number of times.

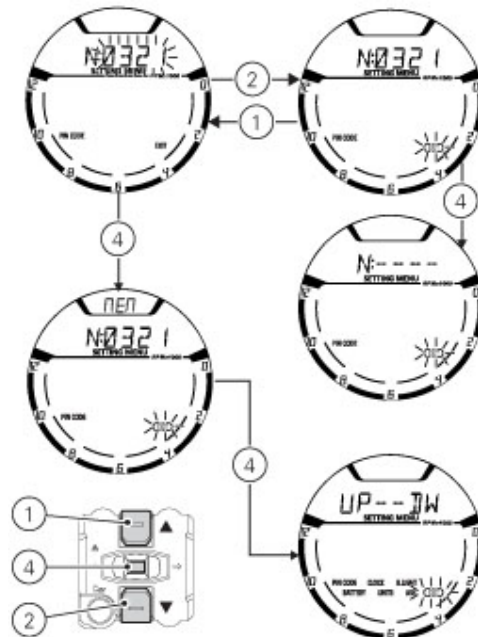

Activations through diagnosis instrument

The DUCATI diagnosis instrument allows performing a series of activations to check some instrument panel functions and resetting parameters or warning lights.

After each activation, the instrument panel will restore its standard functions.



Note

The activations must be performed only with key turned to ON, engine off and battery voltage ≥ 11.0 V.

PIN CODE reset

This activation allows "erasing" the previously stored PIN CODE to enter a new one.

Pin Code

This function allows enabling and then modifying a 4-digit PIN code to "temporarily" start the vehicle in case of Immobilizer system malfunction.

The PIN CODE is initially not present in the motorcycle, it must be activated by the user by entering his/her 4-digit PIN in the instrument panel, otherwise the motorcycle cannot be started temporarily in the case of a malfunction. To activate this function, refer to "Entering the PIN CODE" procedure.

To change the PIN refer to "Changing the PIN CODE" procedure.

In order to temporarily start the motorcycle in case of malfunction of the Immobilizer system, please refer to the "Vehicle Release" procedure.

Warning

The motorcycle owner must activate (store) the PIN code; if there is already a stored PIN, contact an Authorised Ducati Dealer to have the function "reset". To perform this procedure, the Authorised Ducati Dealer may ask you to demonstrate that you are the owner of the motorcycle.

Entering the PIN CODE

To activate the PIN CODE function and enter your own PIN CODE you must open the SETTING MENU. Select PIN CODE option, by pressing button (1) or (2). Once function is highlighted, press CONFIRM MENU button (4).

Note

If upon accessing this function, the "O : " (Old) indication is displayed together with four flashing dashes " - - - - ", a PIN code is already stored and the Function is already active.

When accessing the function, the display will show "N:" (new) followed by four flashing dashes " - - - -".

To go back to the previous indication without activating a PIN CODE, press button (2); as soon as the "EXIT" box starts flashing, press button (4) again.

Entering the code:

- 1 Press button (4), only one digit indicating "0" starts flashing;
- 2 Each time you press button (2) the displayed number increases by one (+ 1) up to "9" and then starts back from "0";
- 3 Each time you press the button (1) the displayed number decreases by one (- 1) up to "1" and then starts back from "0";
- 4 To confirm the number, press the button (4);

Repeat the procedures until you confirm all the digits of the PIN CODE.

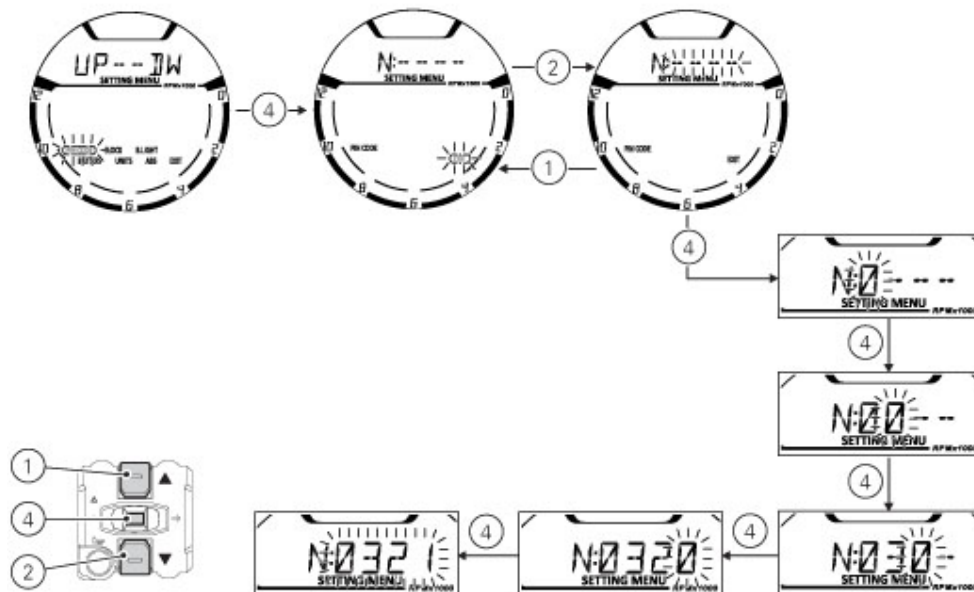

Press button (4) to confirm the fourth and last figure: the 4-digit code starts flashing.

To memorise the entered PIN, keep button (4) pressed for 3 seconds.

If new settings have been saved, "MEM" will be shown and the "EXIT" box will be flashing.

To quit, press button (4).

Once the first PIN CODE is stored, this menu page is no longer available and is replaced by the page for changing the PIN CODE.

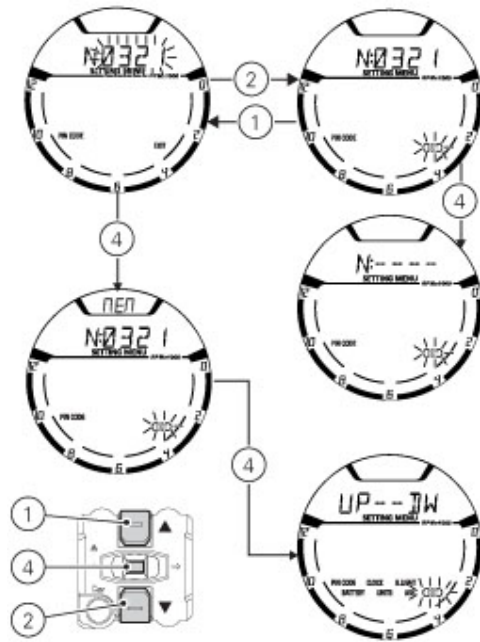

Activations through diagnosis instrument

The DUCATI diagnosis instrument allows performing a series of activations to check some instrument panel functions and resetting parameters or warning lights. After each activation, the instrument panel will restore its standard functions.



Note

The activations must be performed only with key turned to ON, engine off and battery voltage ≥ 11.0 V.

PIN CODE reset

This activation allows "erasing" the previously stored PIN CODE to enter a new one.

VIN CODE

The VIN code is an alphanumeric code with 17 characters that clearly identifies a vehicle (family, model, country, serial number, ...). This code can be stored in the instrument panel and read through the DUCATI diagnosis instrument with suitable KWP2000 inputs.

Clock setting function (CLOCK)

This function allows setting the clock.

To view this function, enter the Setting Menu, use button (1) or (2) to select CLOCK and press button (4).

To access the setting function, keep button (2) pressed for 3 seconds.

After 3 seconds it is possible to set the clock as follows:

- the "AM" indication starts flashing;
 - if you press button (2) the "PM" indication starts flashing;
 - if you press button (1) you will return to the previous step (if it is 00:00, when switching between "AM" to "PM", 12:00 will be displayed);
- press button (4) to shift to hour setting, hours will start flashing;
 - each time you press button (2), the digit will increase by one hour. If you hold button (2) down, the number increases cyclically in steps of one hour every second (when the button is held depressed, the hours do not flash);
- pressing button (4) gives access to the minute setting mode; minutes start to flash;
 - each time you press button (2), the digit will increase by 1 minute. If you hold button (2) pressed, the count increases cyclically in steps of 1 minute every second;
 - if button (2) is kept pressed for more than 5 seconds, steps increase in steps of 1 every 100 ms (seconds will not flash while button (2) is pressed).

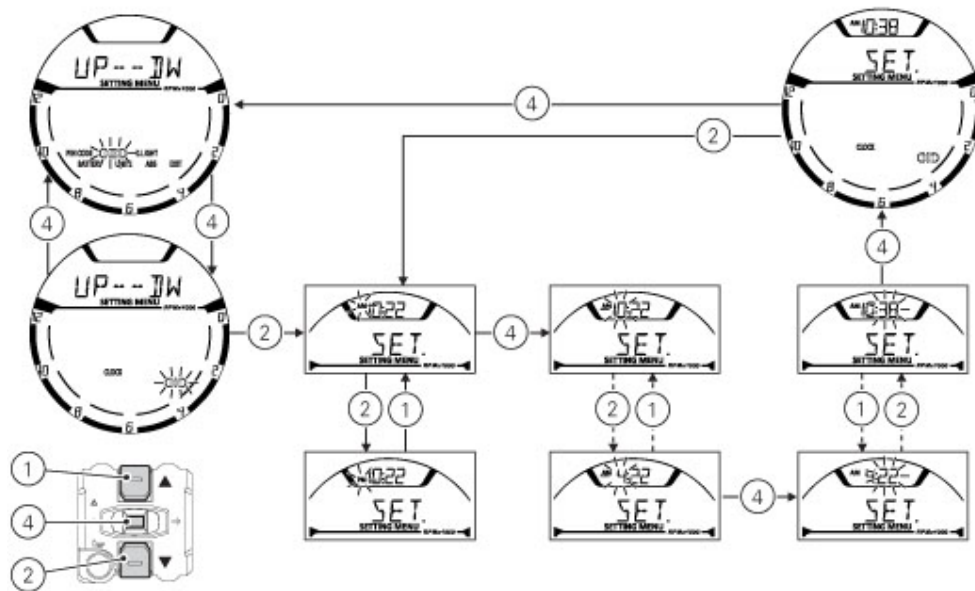

To confirm (store) the new set time press button (4).

The EXIT box starts flashing, press button (4) to go back to the setting menu.



Note

In case of battery off, when the Voltage is restored and upon next Key-On, clock will have to be set again, i.e. it will automatically start counting from 00:00.

To quit, press button (4).

Instrument panel back-lighting setting (B.LIGHT)

This function allows adjusting the backlighting intensity.

To set the backlighting, enter the SETTING MENU, use buttons (1) and (2) to select "B.LIGHT" and press button (4) to confirm.

When accessing the function, the active mode flashes whereas the MENU and EXIT messages will be steady on.

Use buttons (1) and (2) to select the desired brightness level (HIGH, MED, LOW) and press button (4) to confirm.

Select HIGH to set the display backlighting maximum brightness - recommended in conditions of strong ambient light.

Select MED to set the display backlighting medium brightness (70%) - recommended in conditions of medium/low ambient light.

Select LOW to set the display backlighting minimum brightness (50%) - recommended in conditions of low ambient light and/or during the night.

After confirming, the "EXIT" box will start flashing.

To exit the menu and go back to the previous page, select "EXIT" and press button (4).

Note

In the event of an interruption of the power supply from the Battery, when power is restored, at the next Key-On, the backlighting will always be set by default to maximum brightness.

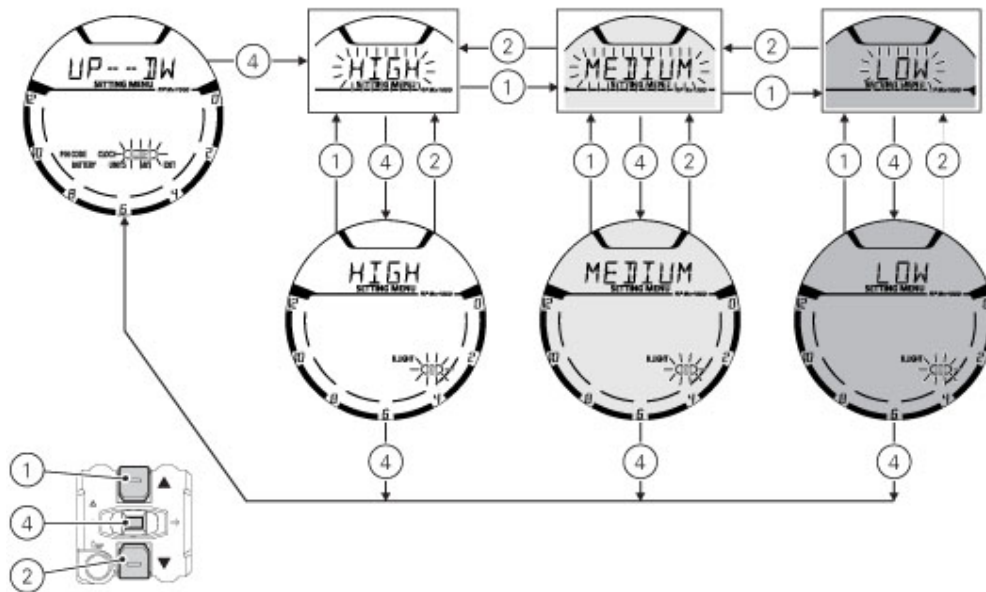

Battery voltage

This function allows you to check the motorcycle battery voltage. Enter the SETTING MENU. Select BATTERY option, by pressing button (1) or (2). Once function is highlighted, press CONFIRM MENU button (4). You open the BATTERY Menu.

The information will be displayed as follows:

- if battery voltage is between 11.8 V and 14.9 V the reading will be displayed steady;
- if battery voltage is between 0.0 and 11.7 Volt the reading will be displayed with "LOW" message flashing;
- if battery voltage is between 15.0 and 25.5 Volt the reading will be displayed with "HIGH" message flashing.

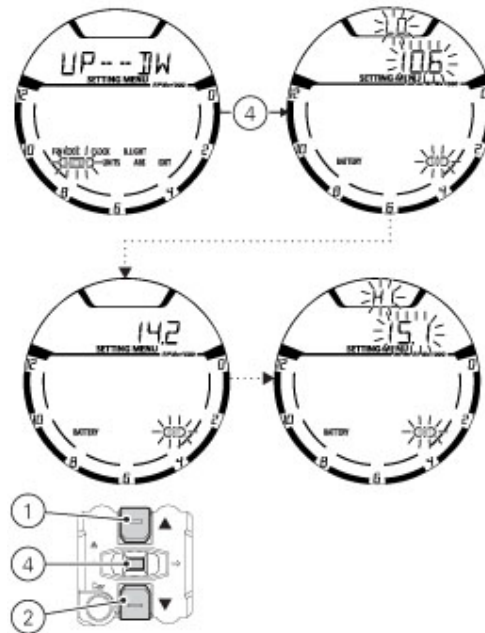

If the instrument panel is not receiving battery voltage value, a string of three dashes "- - -" is displayed. To quit the menu and go back to Setting Menu main page, select EXIT and press button (4).

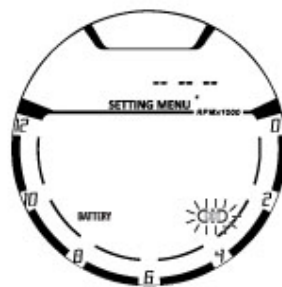

ABS control unit enabling/disabling

This function allows enabling or disabling the ABS system. Enter the SETTING MENU.

Select the parameter to be customised (ABS), by pressing button (1) or (2). Once the desired parameter is highlighted, press CONFIRM MENU button (4).

When entering the function, the currently set ABS status will be displayed:

On = enabled, Off = disabled.

Menu indicates the available alternative option (RQ):

RQ OFF when current status is "On", RQ ON when current status is "Off".

To quit the function without changing set status, select EXIT using button (2); when its box is flashing, press button (4).

To select a different status than the one set, press button (1); alternative option (RQ) starts flashing in the Menu.

Press button (4) for 3 seconds to confirm. WAIT is displayed in the Menu for approx. 5 seconds. New status will then become steady on and "EXIT" box will be flashing.

Press button (4) to quit the function.

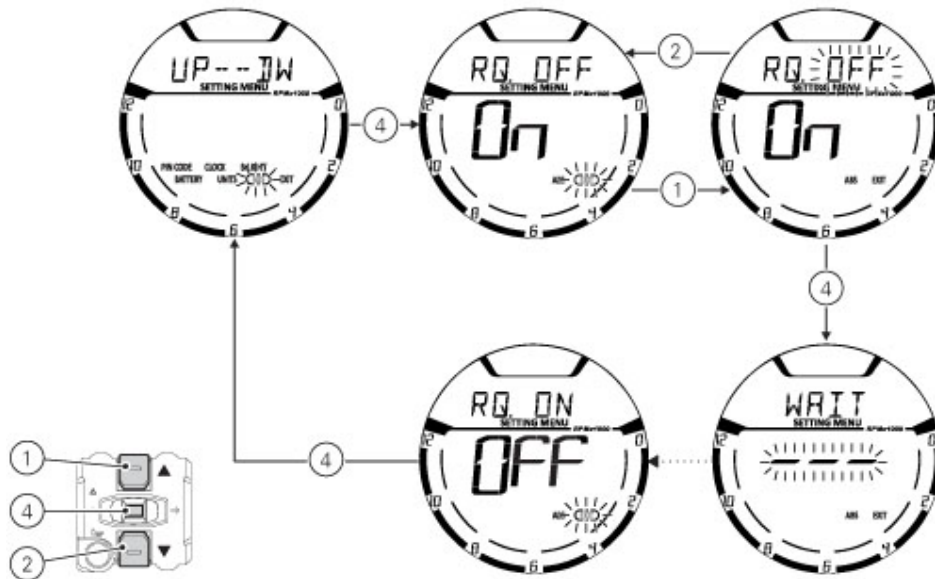

Note

By setting "--" (Off), the ABS will be disabled and the relevant warning light will start flashing.

Important

When setting the ABS OFF, Ducati recommends paying particular attention to the braking and riding style.

If the ABS is in fault, "Err" is displayed when entering the function and Menu will indicate "NO RQ", since no selection is actually possible. "EXIT" box is flashing. Press button (4) for 3 seconds to quit the function.



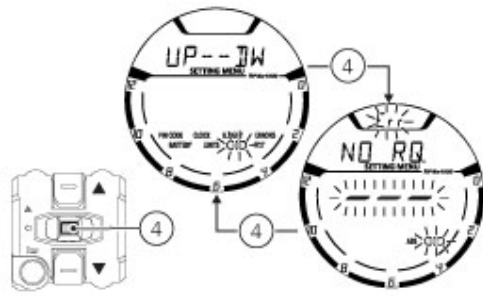

Setting menu

This menu allows enabling, disabling and setting some motorcycle functions.

To enter the SETTING MENU it is necessary to hold button (3) for 2 seconds, with Key-ON and motorcycle actual speed \leq (lower than or equal to) 20 km/h: within this menu, it is no longer possible to view any other function.

The SETTING MENU displays the following functions:

- PIN CODE (activation and modification of PIN CODE);
- CLOCK (clock settings);
- B.LIGHT (backlighting settings);
- BATTERY (battery voltage indication);
- UNITS (units of measurement settings);
- ABS (ABS control unit enabling/disabling);
- EXIT (to quit the Setting Menu).

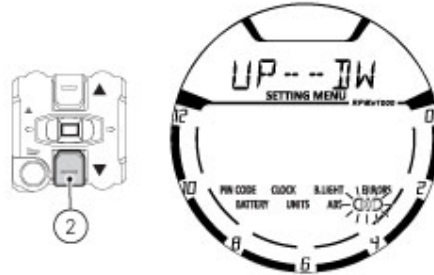

For safety reasons, the setting menu can be accessed only when vehicle speed is below or equal to 20 Km/h; if this menu is accessed and vehicle speed is above 20 Km/h, the instrument panel will automatically quit it and shift back to main screen.

Press buttons (1) and (2) to highlight the customisable parameters one by one: in particular, use button (2) to highlight the following item and button (1) to highlight the previous item.

After highlighting the required parameter, press button (4) to open the corresponding MENU (M) page.

If function is not available or temporarily disabled, the MENU page can not be opened.

To quit the SETTING MENU you shall highlight "EXIT" and press CONFIRM MENU button (4).

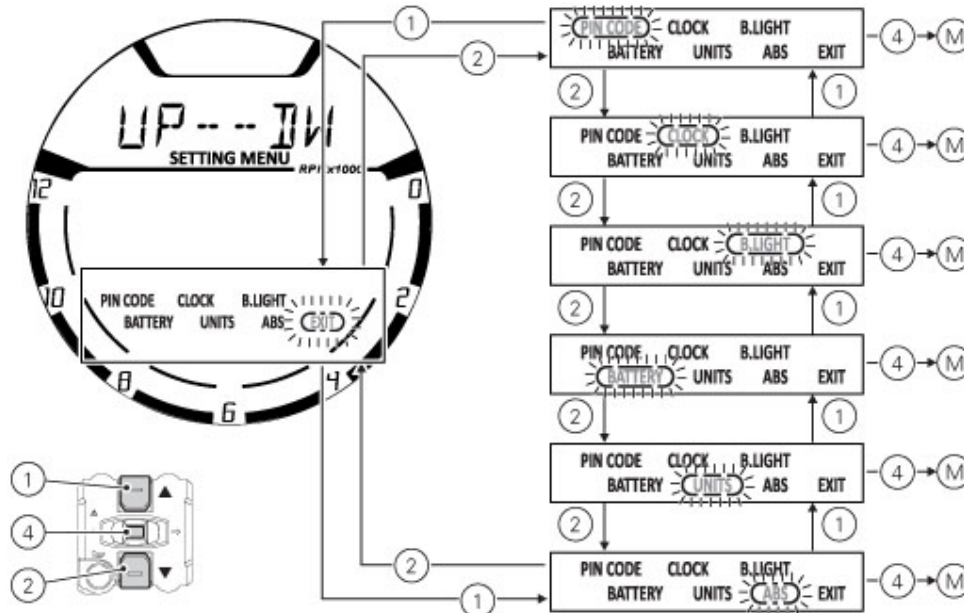

DESMO SERVICE indication

When the service threshold is reached, the warning for the type of service required is triggered: DESMO SERVICE. The indication includes displaying for 5 seconds the flashing message "SERVICE", the Desmo symbol and the message "DESMO" upon each Key-ON; after 5 seconds, both the message "SERVICE" and the Desmo symbol become steady until Key-OFF or until an Authorised Ducati Service Centre performs a reset.



Activations through diagnosis instrument

The DUCATI diagnosis instrument allows performing a series of activations to check some instrument panel functions and resetting parameters or warning lights. After each activation, the instrument panel will restore its standard functions.

Note

The activations must be performed only with key turned to ON, engine off and battery voltage ≥ 11.0 V.

The "Desmo service" reset allows disabling the relevant icon displayed on the instrument panel. After the reset, the indication remains off until reaching the following mileage set for this service.

DESMO SERVICE countdown indication

After OIL SERVICE zero indication first reset (at 1,000 km - 600 mi), the instrument panel activates the countdown of the kilometres (or miles) left before the following service operation: DESMO SERVICE. The kilometre count indication is shown upon Key-ON for 2 seconds; when there are 1,000 km (600 miles) left before the next service operation, the indication turns on upon every Key-ON for 5 seconds. In other words, upon key-on the message "SERVICE" and the Desmo symbol are displayed together with the indication of the kilometres left before the following service operation.

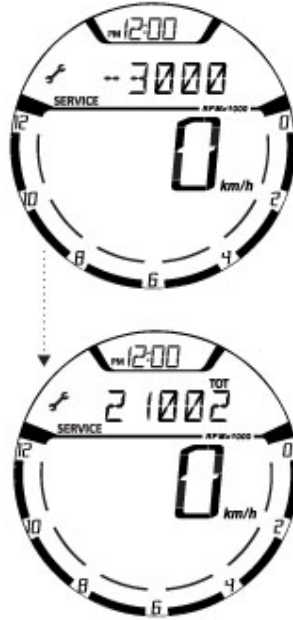

Activations through diagnosis instrument

The DUCATI diagnosis instrument allows performing a series of activations to check some instrument panel functions and resetting parameters or warning lights. After each activation, the instrument panel will restore its standard functions.

Note

The activations must be performed only with key turned to ON, engine off and battery voltage ≥ 11.0 V.

The "Desmo service" reset allows disabling the relevant icon displayed on the instrument panel. After the reset, the indication remains off until reaching the following mileage set for this service.

OIL SERVICE zero warning

The first maintenance indication is OIL SERVICE zero, enabled for 5 seconds upon each key-on when the odometer counter reaches the first 1,000 km (600 mi).

The indication includes displaying for 5 seconds the flashing message "SERVICE", the Oil symbol and the message "OIL" upon each Key-ON; after 5 seconds, both the message "SERVICE" and the Oil symbol become steady until Key-OFF or until an Authorised Ducati Service Centre performs a reset.

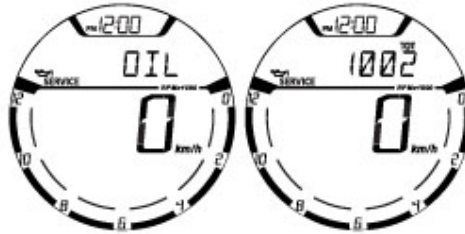

Activations through diagnosis instrument

The DUCATI diagnosis instrument allows performing a series of activations to check some instrument panel functions and resetting parameters or warning lights.

After each activation, the instrument panel will restore its standard functions.



Note

The activations must be performed only with key turned to ON, engine off and battery voltage ≥ 11.0 V.

The "Oil service" reset allows disabling the relevant icon displayed on the instrument panel.

After the reset, the indication remains off until reaching the following mileage set for this service.

Service indication (SERVICE)

This indication shows the user that the motorcycle is due for service and must be taken to a Ducati Authorised Service Centre.

The service warning indication can be reset only by the Authorised Ducati Service Centre during servicing.

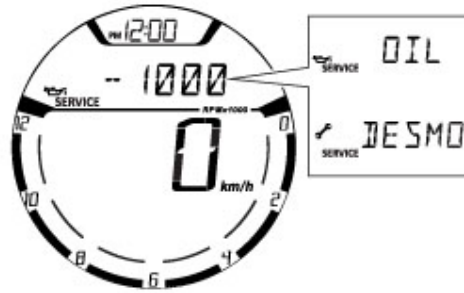

High engine temperature

This Function shows an alert indicating that engine temperature reached high values: warning triggers when engine temperature exceeds 200°C.

- flashing HI message;
- steady temperature icon and set unit of measurement (°C or °F).



Note

When this warning is triggered, the instrument panel will not display the clock until value gets equal to or below 200°C.



Note

If engine temperature sensor is in fault or if instrument panel is not receiving engine temperature information, a string of flashing dashes "- - -" is displayed.

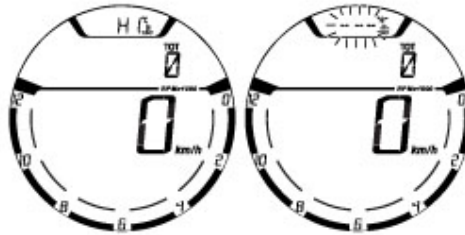

Clock

The instrument panel receives information about the time to be displayed.
The instrument panel shows the time in the following format:

- hh (hours) : mm (minutes);
- with the message AM (for values ranging between 0:00 and 11:59), or PM (for values ranging between 12:00 and 12:59 and between 1:00 and 11:59).

In case of power supply interruption (faulty battery), the clock is reset and starts automatically from "0:00".

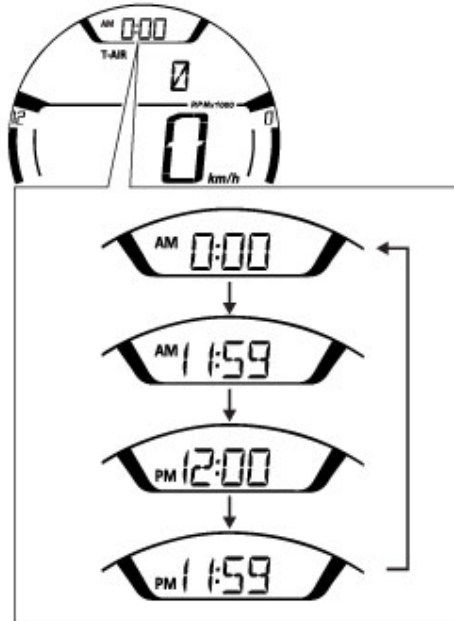









Displayed errors description

Displayed error	Description
ENGINE	Throttle position sensor malfunction
	Throttle motor or relay malfunction (stepper motor)
	Pressure sensor malfunction
	Engine coolant temperature sensor malfunction
	Injection relay malfunction
	Ignition coil malfunction
	Injector malfunction
	Engine rpm sensor malfunction
	Lambda sensor or Lambda sensor heater malfunction
	Motorcycle starting relay malfunction
	Secondary air system valve malfunction
AIR – T.	Ambient air temperature sensor malfunction
BATT.	Battery voltage too high or too low
FUEL	Reserve NTC sensor malfunction
ABS	ABS control unit faulty communication / operation
	Front and/or rear speed sensor malfunction

CAN	CAN line error (communication line across all control units)
IMMO	Generic error
DSB	DSB control unit faulty communication / operation
SD.STND	Side stand sensor not working

Error icons table

WARNING LIGHT / ERROR MESSAGE		ERROR
	ENGINE	Engine control unit
	AIR – T.	Air temperature sensor
	BATT.	Battery voltage
	SPEED	Speed sensor
	FUEL	Low fuel sensor
	ABS	ABS control unit
	CAN	Can Bus OFF
	IMMO	Immobilizer antenna
	DSB	Instrument panel control unit

Error warnings

Any active errors are displayed in the MENU.
MENU functions can still be viewed by pressing button (2).

If several errors are active, the corresponding indications will be displayed one after the other, each remaining on display for 3 seconds.

When an error is triggered the EOBD light turns on as well.

Warning

When one or more errors are displayed, always contact a Ducati Dealer or authorised Service Centre.

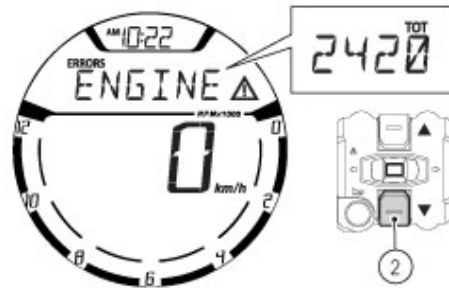

Errors

The instrument panel manages error warnings in order to allow the rider to identify any abnormal motorcycle behaviour in real time.

Upon Key-ON - if there are active errors - or during normal operation of the vehicle - whenever an error is triggered - the instrument panel turns the EOBBD light and Warning symbol ON and indicates the triggered error.



Ambient air temperature (AIR)

The instrument panel displays the ambient temperature in the set unit of measurement (°C or °F), followed by the set unit of measurement and the message T-AIR.

The temperature value is displayed when ranging from -39 °C to +124 °C (or -38 °F ÷ +255 °F).

For any different temperature (below -39 °C (-38 °F) or above +124 °C (+255 °F)) a string of three dashes " - - - " is steadily displayed, followed by the unit of measurement.

If the air temperature sensor is in fault, the instrument panel will show three flashing dashes " - - - " as air temperature value, followed by the unit of measurement and the EOBD light will turn on.

Note

When the motorcycle is stopped, the engine heat could influence the displayed temperature.

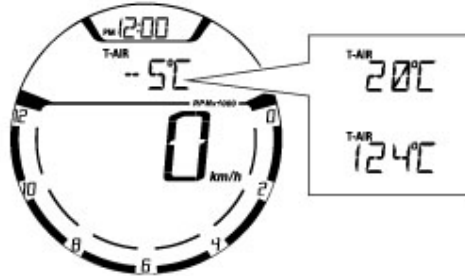

Partial fuel reserve counter (TRIP FUEL)

The fuel trip meter counts and displays the distance covered by the motorcycle on reserve (since the low fuel light turns on) with the set unit of measurement (km or mi).

When the Low Fuel Light (A) turns on, the display automatically shows the TRIP FUEL function, regardless of the currently displayed function; then, it is possible to toggle through the other Menu functions using button (2).

Trip fuel reading remains stored even after Key-Off until the motorcycle is refueled.

Count is interrupted automatically as soon as fuel is topped up to above minimum level.

When the reading exceeds the maximum value of 9999.9 km or 9999.9 mi, distance travelled is reset and the meter automatically starts counting from 0 again.

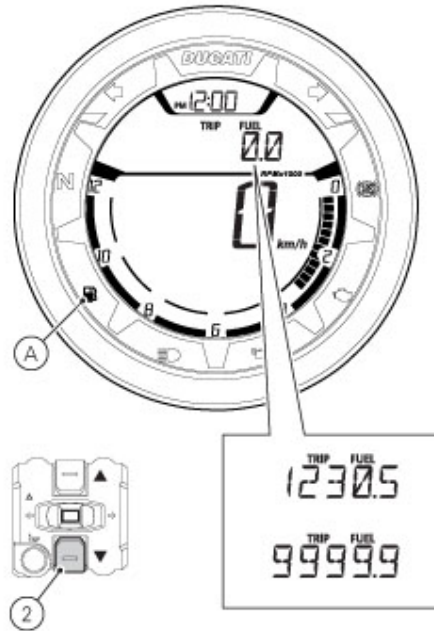

Note

Whenever the system unit of measurement is changed from the "SET UNITS" function of the Setting menu or in case of power off (Battery Off), the distance travelled is reset and the meter starts counting from zero again (considering the new set units of measurement).

Trip meter 2 (TRIP 2)

The trip meter counts and displays the partial distance covered by the motorcycle with the set unit of measurement (km or mi).

When the reading exceeds the maximum value of 9999.9 km or 9999.9 mi, distance travelled is reset and the meter automatically starts counting from 0 again.

While the trip meter is displayed, press button (1) for 3 seconds to reset TRIP 2.

The TRIP 2 counter is automatically reset in case the system unit of measurement is changed manually or if the power supply is interrupted (faulty battery): the counter will then start back from zero, considering the new units of measurement.

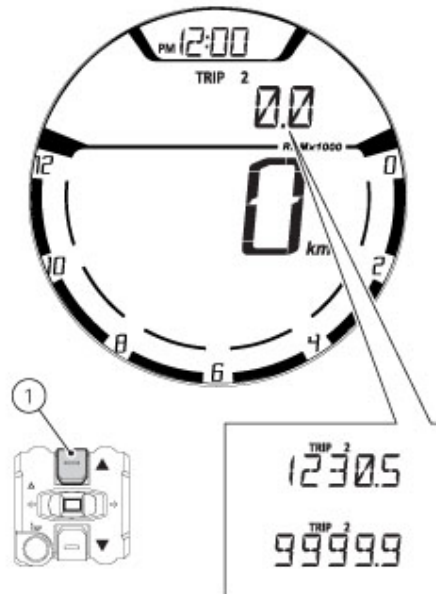

Trip meter 1 (TRIP 1)

The trip meter counts and displays the partial distance covered by the motorcycle with the set unit of measurement (km or mi).

When the reading exceeds the maximum value of 9999.9 km or 9999.9 mi, distance travelled is reset and the meter automatically starts counting from 0 again.

While the trip meter is displayed, press button (1) for 3 seconds to reset TRIP 1.

The TRIP 1 counter is automatically reset in case the system unit of measurement is changed manually or if the power supply is interrupted (faulty battery): the counter will then start back from zero, considering the new units of measurement.

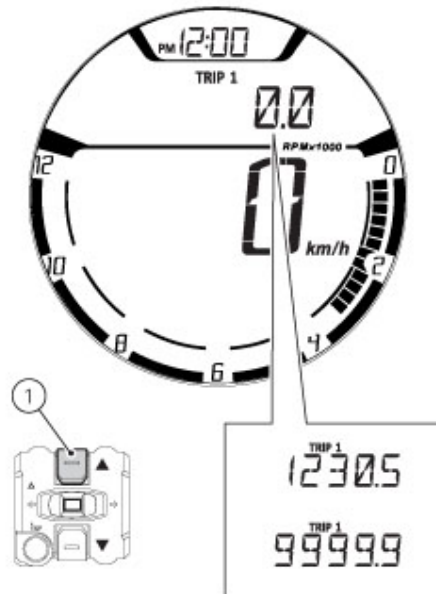

Odometer (TOT)

The odometer counts and displays the total distance covered by the motorcycle with the set unit of measurement (km or mi).

The odometer number (in km or miles) is displayed with the message TOT and the indication of the unit of measurement.

When the maximum value is reached (199999 km or 199999 mi) the instrument panel will permanently display said value.

The odometer value is saved permanently and cannot be reset under any circumstances.

The reading is not lost in case of a power OFF (Battery OFF).

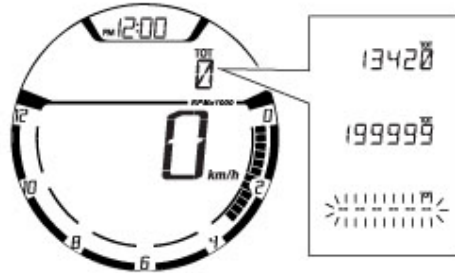

Note

Upon Key-ON, the instrument panel always shows the Odometer indication for 10 seconds, then shows the user's settings page.

Note

If a string of flashing dashes "-----" is displayed within odometer function, please contact a Ducati Dealer or Authorised Service Centre.

Odometer Update

The DUCATI diagnosis instrument allows performing a series of activations to check some instrument panel functions and resetting parameters or warning lights. After each activation, the instrument panel will restore its standard functions.

Note

The activations must be performed only with key turned to ON, engine off and battery voltage ≥ 11.0 V.

This function allows copying the km value saved in the odometer when replacing the instrument panel or the engine control unit (ECU).

When replacing the instrument panel or the engine control unit (ECU), it is necessary that the authorised dealer copies (*) the km value to the new control unit using the DDS Diagnosis Instrument.

Until this procedure is performed, the instrument panel display will show some flashing dashes "-----" instead of the Odometer value.

The procedure is successfully completed when the display shows the odometer value. (*): for the "procedure" to be followed with the DDS instrument to be added in the Workshop Manual, contact the SERVICE.

Menu 1 functions

MENU 1 functions are:

- Odometer (TOT);
- Trip meter 1 (TRIP 1);
- Trip meter 2 (TRIP 2);
- Partial fuel reserve counter (TRIP FUEL);
- Ambient air temperature (T-AIR).

By pressing button (2) it is possible to view the functions of MENU 1.

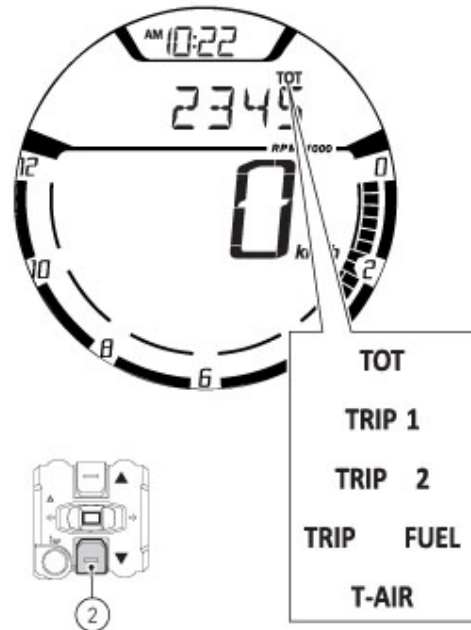

Engine rpm indication (RPM)

This function allows displaying engine rpm.

Instrument panel receives rpm value and displays it.

The information is displayed by the bargraph filling from the right to the left according to the engine rpm.



The thresholds before the rpm limiter are: 1st threshold 8900 rpm (A).

When the rev limiter value (B) is reached, the warning lights start flashing.

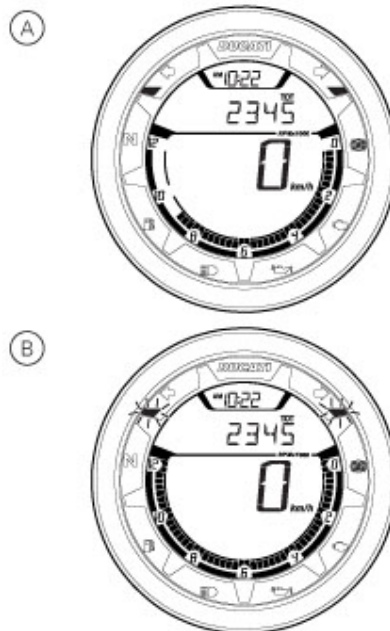

Activations through diagnosis instrument

The DUCATI diagnosis instrument allows performing a series of activations to check some instrument panel functions and resetting parameters or warning lights. After each activation, the instrument panel will restore its standard functions.



The activations must be performed only with key turned to ON, engine off and battery voltage ≥ 11.0 V.

This activation allows checking for instrument panel malfunctions or display problems of the rpm indication. Upon receiving this input the instrument panel shows for 5s the following values in sequence:

- ' 1000 rpm '
- ' 5000 rpm '
- ' 11000 rpm '.

Motorcycle speed

This function allows displaying the vehicle speed (km/h or mph according to the specific application). The instrument panel receives information about the actual motorcycle speed (calculated in km/h) and displays the value increased by 5% and converted in the set unit of measurement (km/h or mph). The max. displayed speed is 299 km/h (186 mph).

- . A string of dashes "- - -" is displayed with the set unit of measurement if:
 - speed is higher than 299 km/h or 186 mph or if instrument panel is not receiving the speed value ("- - -" steady ON);
 - the rear speed sensor is in fault (flashing "- - -").



Activations through diagnosis instrument

The DUCATI diagnosis instrument allows performing a series of activations to check some instrument panel functions and resetting parameters or warning lights. After each activation, the instrument panel will restore its standard functions.



Note

The activations must be performed only with key turned to ON, engine off and battery voltage ≥ 11.0 V.

This activation allows checking for instrument panel malfunctions or display problems of the speed indication.

Upon receiving this input the instrument panel shows for 5s the following values in sequence:

- ' 50 km/h '
- ' 100 km/h '
- ' 299 km/h '.

Main functions

The functions displayed in the Standard screen are the following:

Main information

- Vehicle speed
- Engine rpm indication (RPM)
- Menu 1 displays the following functions:
 - a) Odometer (TOT)
 - b) Trip meter 1 (TRIP 1)
 - c) Trip meter 2 (TRIP 2)
 - d) Partial fuel reserve counter (TRIP FUEL)
 - e) Ambient air temperature (AIR)
 - f) Clock

Additional information

- Service indication (SERVICE)
- ERROR indication

The functions within the Setting Menu that can be modified by the user are the following:

- PIN CODE (activation and modification of PIN CODE);
- CLOCK (clock settings);
- LIGHT (backlighting settings);
- BATTERY (battery voltage indication);
- UNITS (units of measurement settings);
- ABS (ABS control unit enabling/disabling);
- EXIT (to quit the Setting Menu).

Parameter setting/displaying

Upon key-on, the instrument panel:

- turns on the display backlighting;
- activates the rev counter which increases from 0 to 12000 and decreases back to 0;
- activates the vehicle speed digits and shows a counting from 0 to 300 and then back to 0;
- turns on the warning lights from right to left.

At the end of the check, the instrument panel displays the main screen ("standard screen") showing the available functions and turns on the warning lights, if necessary.

During this first check stage, if the motorcycle speed exceeds 20 km/h (12 mph) (actual speed), the instrument panel will stop:

- the display check routine and display the standard screen containing updated information;
- the warning light check routine and leave ON only the warning lights that are actually active at the moment.



Data displayed on the main screen are as follows:

- 1 Engine speed.
- 2 Motorcycle speed.
- 3 MENU 1 (Odometer, Trip 1, Trip 2, Trip Fuel, Air temperature, Error warning - only if active).
- 4 Clock.
- 5 SERVICE indication (only if active).
- 6 Setting menu.
- 7 Side stand status.



From the main screen, press button (2) on LH switch to view Menu 1 information.

- Odometer (TOT);
- TRIP 1;

- TRIP 2;
- TRIP FUEL (when function is active);
- T – AIR.

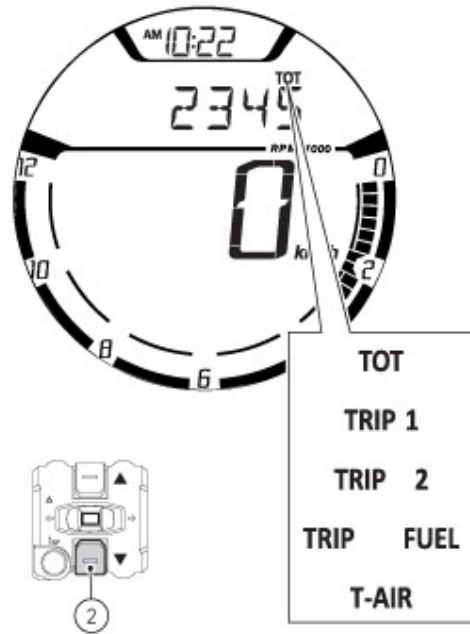

The instrument panel stores Menu 1 settings in use upon KEY-OFF. On the following KEY-ON, previously stored Menu 1 pages are displayed.
In case of sudden and unexpected power OFF, the instrument panel displays the default settings upon the following KEY-ON:

- Menu 1 default page = Odometer (TOT).

Upon KEY-ON, for every display layout, instrument panel shows for 10 seconds in Menu 1 the "Odometer" page and then shows the page saved upon previous KEY-OFF.

Hold the button (2) for 3 seconds, when actual motorcycle speed is \leq (lower than or equal to) 20 km/h (12 mph), to enter the Setting Menu, where you can set any function.

Important

You can enter the SETTING MENU only if vehicle actual speed is \leq (lower than or equal to) 20 km/h (12 mph). Within the SETTING MENU, if vehicle actual speed exceeds 20 km/h (12 mph), the instrument panel automatically quits the menu and shows the Standard Screen.

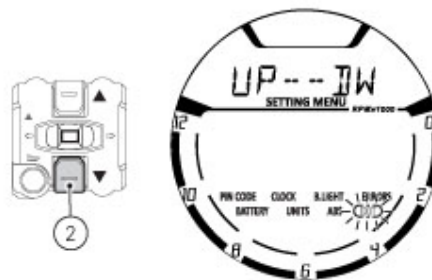

Function buttons

1) UP CONTROL SWITCH

Button used to display and set instrument panel parameters with the position

2) DOWN CONTROL SWITCH

Button used to display and set instrument panel parameters with the position.

3) HIGH-BEAM FLASH BUTTON (FLASH)

This button is the high-beam flasher.

4) TURN INDICATORS CANCEL BUTTON

The turn indicators cancel button may also be used for the CONFIRM MENU function, for selecting the riding mode. Push this button for 3 seconds to the left side to activate the "Hazard" function (all 4 turn indicators).

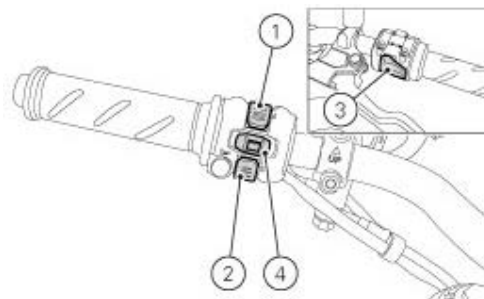

Technological Dictionary

Anti-lock Braking System (ABS) 9M

ABS 9M system is a two-channel latest-generation system that actuates combined braking with anti lift-up function for the rear wheel so as to guarantee not only a reduced stopping distance, but also a higher stability under braking.

Acronyms and abbreviations used in the Manual

ABS

Antilock Braking System

CAN

Controller Area Network

DDA

DUCATI Data Acquisition

DSB

Dashboard

ECU

Engine Control Unit

Instrument panel

- 1) LCD.
- 2) REV COUNTER (rpm).
It indicates engine rpm value.
- 3) NEUTRAL LIGHT N (GREEN).
Comes on when in neutral position.
- 4) HIGH BEAM LIGHT



(BLUE).

It turns on to indicate that the high beam lights are on and when the flasher is activated.

- 5) ENGINE OIL PRESSURE LIGHT



(RED).

Comes on when engine oil pressure is too low. It must turn on at "KEY-ON", but must turn OFF a few seconds after the engine has started. It may shortly come on when the engine is hot, however, it should go out as the engine revs up.



Important

If the ENGINE OIL light stays ON, stop the engine or it may suffer severe damage.

- 6) FUEL WARNING LIGHT



(AMBER YELLOW).

Comes on when fuel is low and there are about 4 litres (1.06 gallons) of fuel left in the tank.

- 7) TURN INDICATOR LIGHTS



(GREEN).

A warning light turns on and blinks when the relevant turn indicator is active; when the warning lights blink at the same time, the HAZARD function is active.

- 8) "ENGINE/VEHICLE DIAGNOSIS - EOBD" LIGHT



(AMBER YELLOW).

It turns on in the case of "engine" and/or "vehicle" errors and in some cases will lock the engine.

- 9) ABS LIGHTS



(AMBER YELLOW).

This turns on to indicate that ABS is disabled or not functioning.

Engine OFF / speed below 5 km/h (3 mph)		
Light OFF	Light flashing	Light steady on
-	ABS disabled with the menu function "ABS"	ABS enabled, but not functioning yet
Engine ON / speed below 5 km/h (3 mph)		
Light OFF	Light flashing	Light steady on
-	ABS disabled with the menu function "ABS"	ABS enabled, but not functioning yet
Engine ON / speed above 5 km/h (3 mph)		
Light OFF	Light flashing	Light steady on
ABS enabled and functioning	ABS disabled with the menu function "ABS"	ABS disabled and not functioning due to a problem

- 10) OVER REV / IMMOBILIZER / ANTI-THEFT SYSTEM (RED)

--	--

	Over rev
No intervention	Light OFF
First threshold (N RPM before the limiter kicks in)	Light steady ON
Limiter	Light ON flashing

 **Note**

Each calibration of the Engine Control Unit may have a different setting for the thresholds that precede the rev limiter and the rev limiter itself.

	Immobilizer
Key-ON status	Light OFF
Key-OFF status	Light ON flashing
Key-OFF status for over 12 hours	Light OFF



SW update

The DSB software can be updated through the DUCATI diagnosis instrument, which uses a suitable dedicated KWP2000 communication protocol.

Diagnostic socket

The diagnostic socket is located in the vehicle rear side. In order to reach it, remove the seat ([Removing the seat](#)).

Left-hand switch

In the event of a fault, the internal connections of the device must be checked in all operating conditions. It is therefore necessary to disconnect the main wiring switch connector and perform the check using an analogue or digital multimeter.



Note

The same test may be done using the "DDS 2" diagnosis instrument.

LEFT-HAND SWITCH CONTROL

Remove the LH handgrip as described in chapter "[Removing the handlebar](#)".

Loosen the screws (1) and remove the left-hand switch.

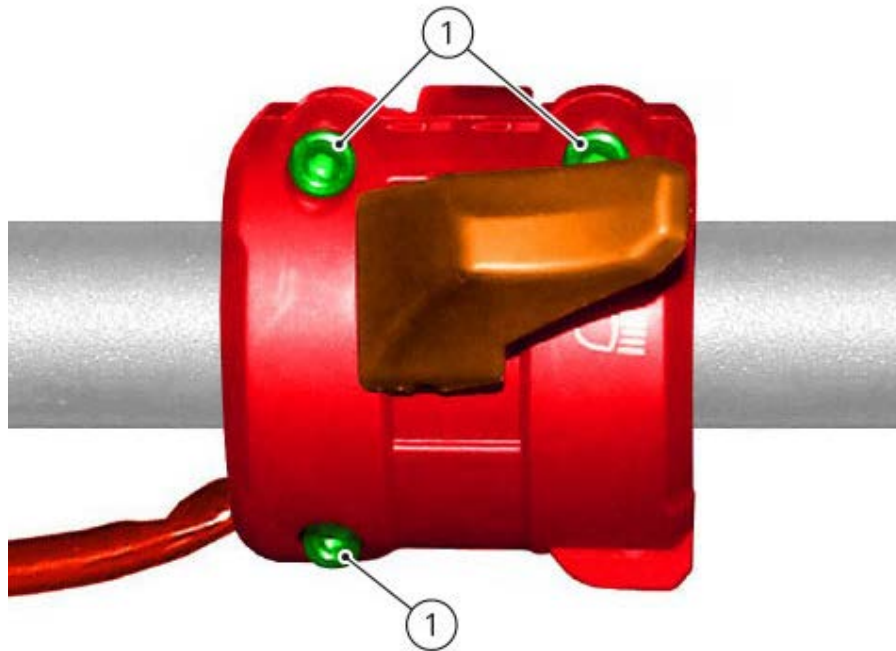

The colours mentioned in the following descriptions refer to the colour of the wires from the switch and not to the colour of the main electric system wires.

Electric diagram

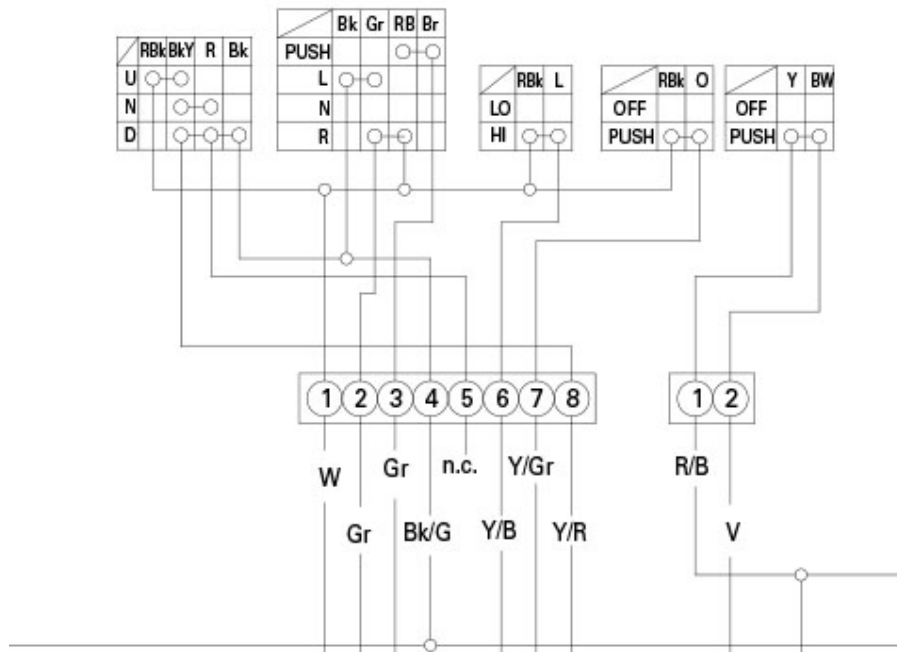

CONTROLS ON LEFT-HAND SWITCH

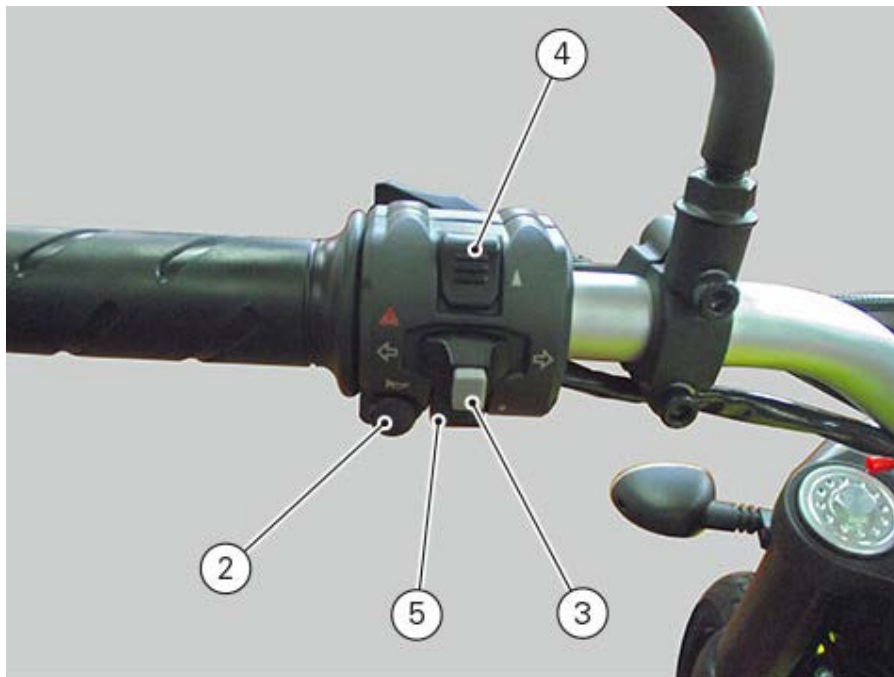

HORN button (2)

Connect the terminals of a multimeter to the Yellow and White/Blue cables to check for electric continuity, which must be available when HORN is pressed.

- When the HORN button is pressed, the resistance value read by the multimeter should be close to zero and, if available, a continuity beep should be heard.
- When the HORN button is not pressed, the resistance value should be infinity (there is no continuity as the electrical contacts inside the push-button are open) and no continuity beep should be heard, if provided. If these conditions are not met, the device must be replaced.

Turn indicator switch (TURN) (3)

The turn indicators cancel button may also be used in the instrument panel for the CONFIRM MENU function, for selecting the riding mode.

Push this button for 3 seconds to the left side to activate the "Hazard" function (all 4 turn indicators). Connect the multimeter to the Red/Blue and Grey wires arriving from the turn indicator switch and check for electrical continuity when operating the right turn signal.

Repeat the above procedure for the left turn indicator, but connect the multimeter to the Black and Grey wires.

Control switch (SET UP) (SET DOWN) (4) (5)

Buttons used to display and set instrument panel parameters.

Connect the multimeter to the Red and Black wires arriving from the instrument panel function selector switch and check for electrical continuity when pressing button (5).

Repeat the same procedure, press button (4) and connect the multimeter to the Red/Black and Blue/Yellow wires.

Low beam and high beam (Hi Beam) (6)

Test using the same procedure, applying the probes of the meter to the Red and Blue wires and moving switch down.

Flash switch (PASSING) (6)

The high-beam flash button may also be used for LAP functions.

Check for continuity between the Red and Orange wires.

Unlike the Hi Beam, switch (6) should be pressed.

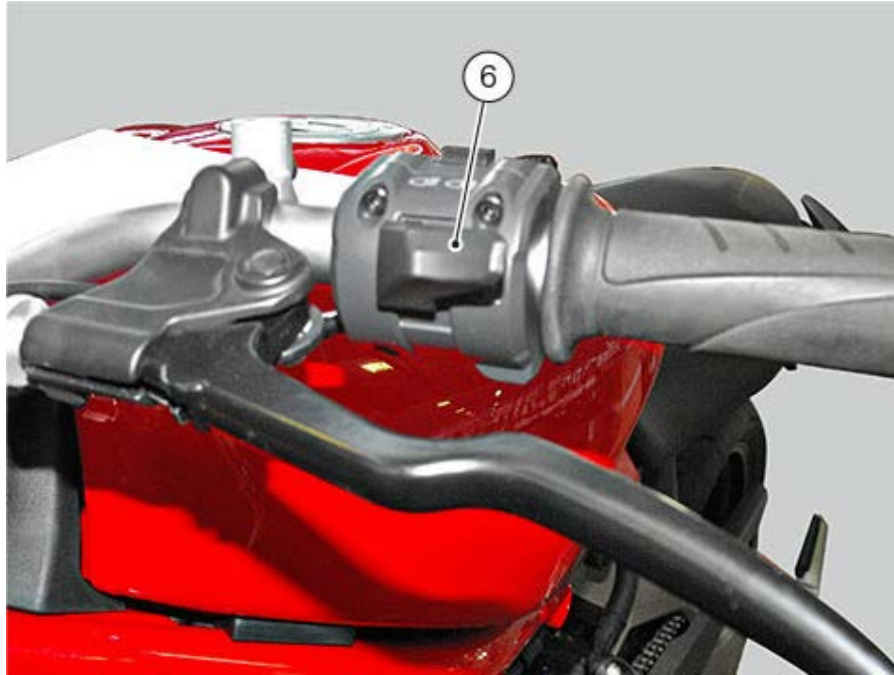

For the refitting procedure refer to chapter "[Refitting the handlebar](#)".

Right-hand switch

In the event of a fault, the internal connections of the device must be checked in all operating conditions. It is therefore necessary to disconnect the main wiring switch connector and perform the check using an analogue or digital multimeter.



Note

The same test may be done using the "DDS 2" diagnosis instrument.

RIGHT-HAND SWITCH CONTROL

Remove the RH handgrip as described in chapter "[Removing the handlebar](#)".

Loosen screws (1) and remove the right-hand switch by disconnecting it from the main connection. The colours mentioned in the following descriptions refer to the colour of the wires from the switch and not to the colour of the main electric system wires.

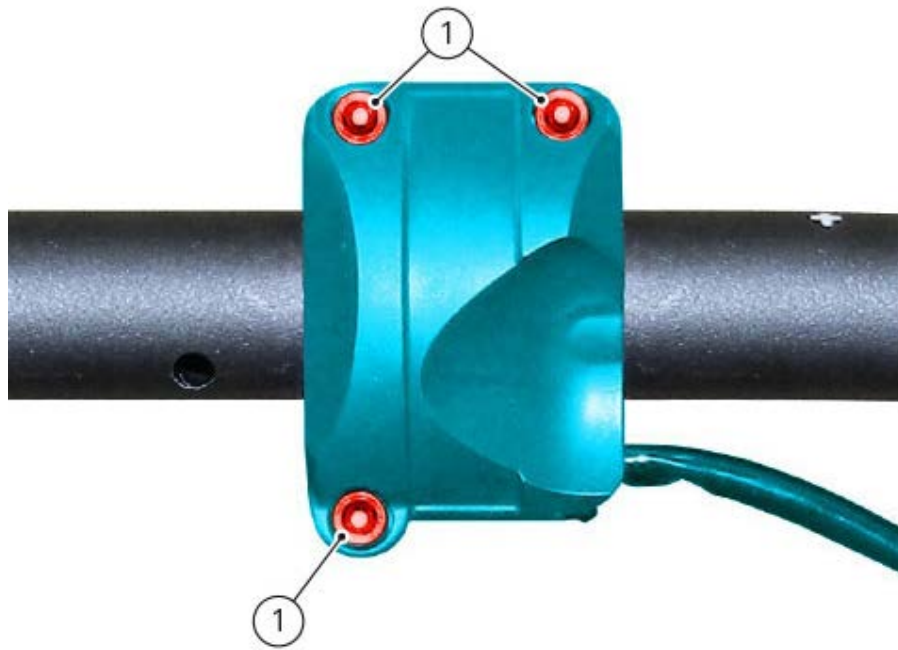

Electric diagram

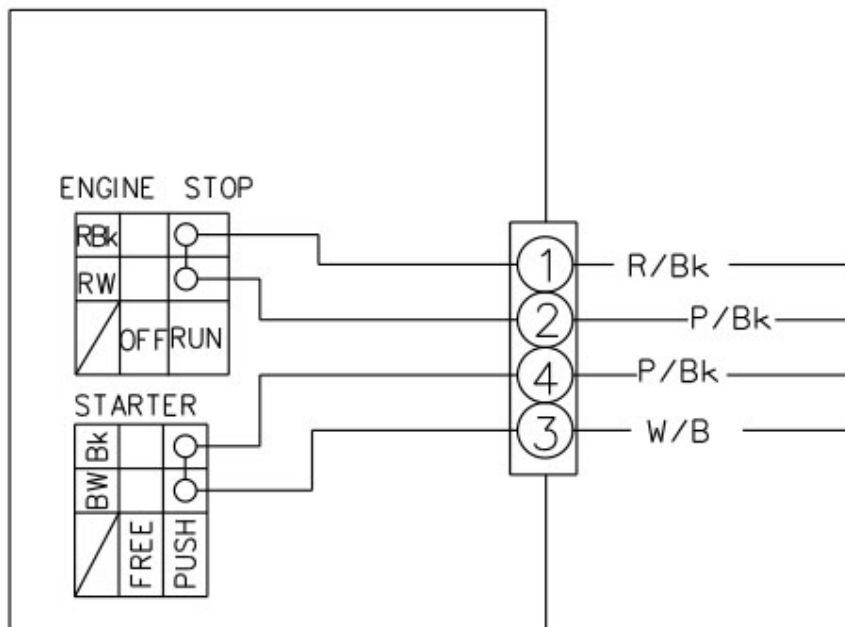

CONTROLS ON RIGHT-HAND SWITCH

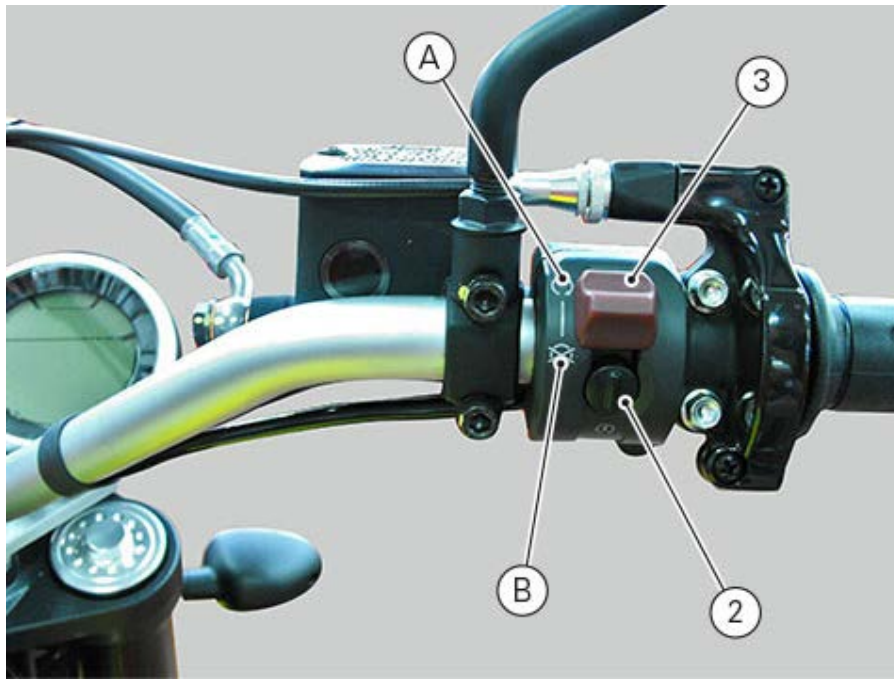

Engine stop button

Using a multimeter, check for continuity between the Red/White and Red/Black wires:

- when button (3) is in RUN position (A), there should be electrical continuity between the two wires;
 - when the button is in the OFF position (B), there should be no electrical continuity between the two wires.
- If these conditions are not met, the engine stop switch is not working correctly and must be replaced.

Starter button

Proceed as described for the engine stop button and check for continuity between the Blue/White and Black wires when the starter button (2) is pressed.

If there is no continuity, the starter button is faulty and must be replaced.

Colours mentioned in the descriptions refer to the colour of wires from the switch and not to the colour of the main electric system wires.

For the refitting procedure refer to chapter "[Refitting the handlebar](#)".

Rear stop switch

The rear STOP switch (1) is located inside the RH footpeg holder plate.

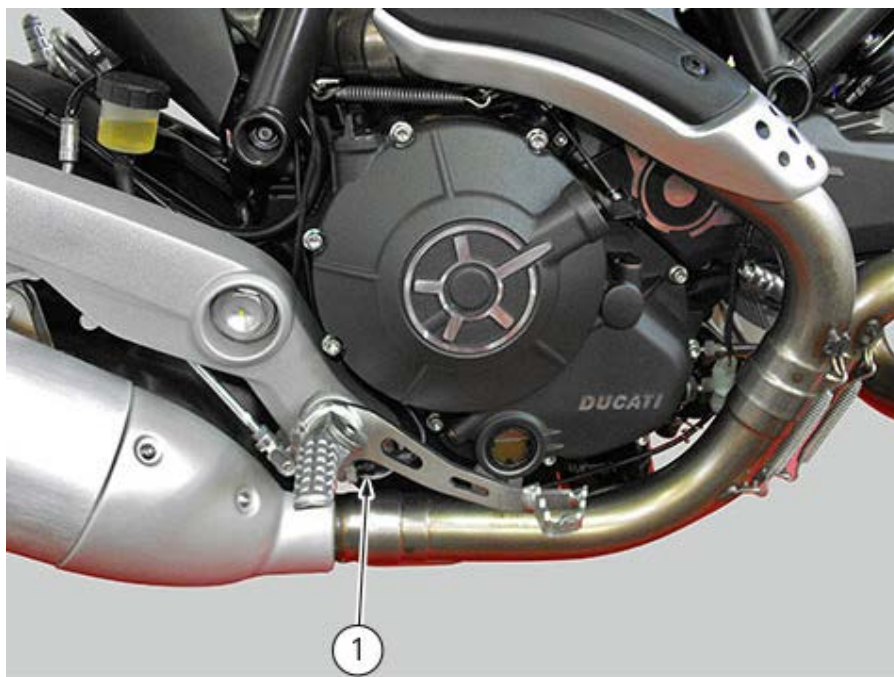

REAR STOP SWITCH CONTROL

To check operation of the rear (1) STOP switch, use a multimeter: when the rear brake lever is operated, there must be electric continuity between the terminals of the corresponding switch. No electric continuity should be available when brakes are not operated.

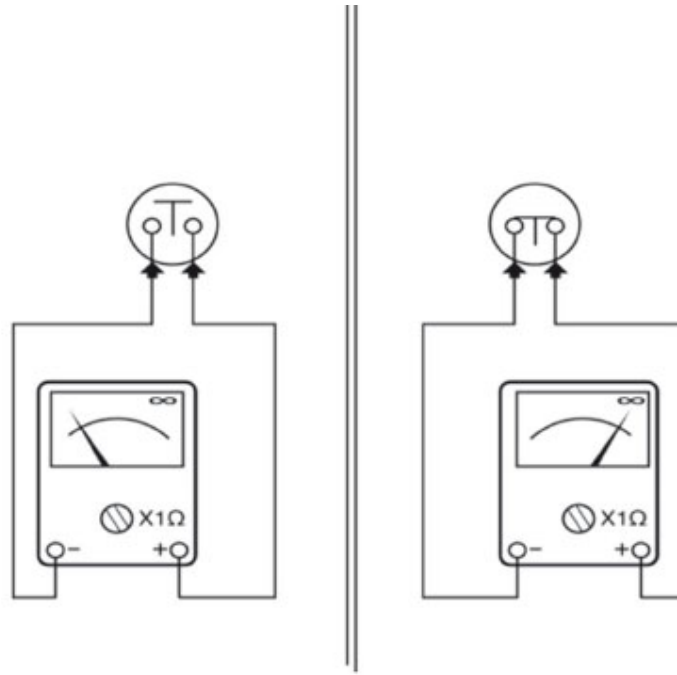

Electric diagram

If these tests fail to produce positive results, the part in question must be replaced.

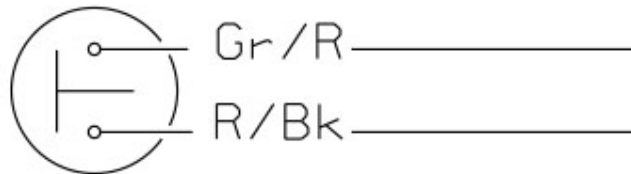

Gear/neutral sensor

The gear sensor (1) is positioned on the vehicle rear RH side, near the solenoid starter.

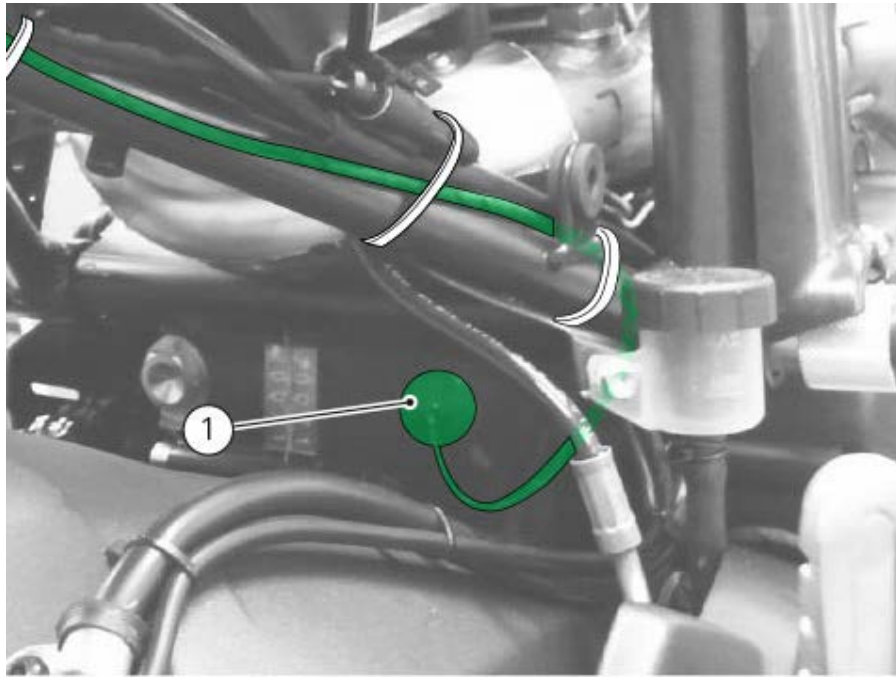

To check the operation of gear sensor (1), connect the DDS 2.

Electric diagram

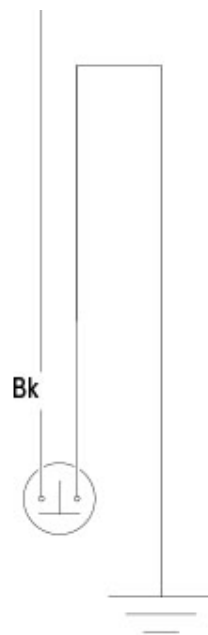

Horn

Supply 12 V (battery) to the two fastons.

With a multimeter connected between the two poles (threaded pins) of the solenoid starter, check for electric continuity.

If there is no electric continuity, ensure that the terminals are not oxidised and apply water repellent spray. Change the horn if the malfunction persists.



Electric diagram

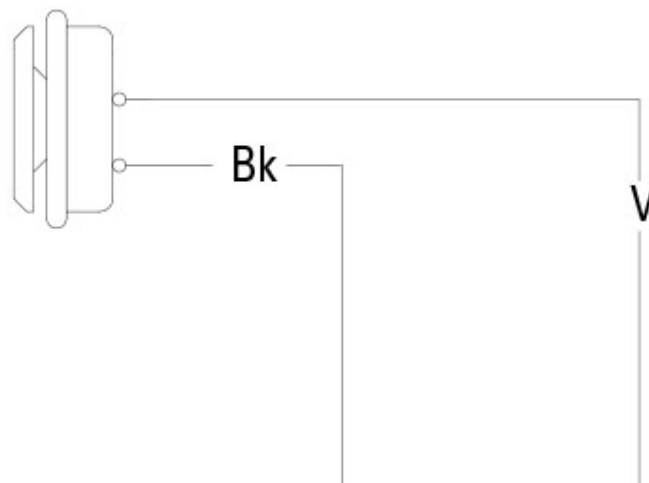

Clutch switch

The clutch switch (1) is located on the clutch lever lower side.



CLUTCH SWITCH CONTROL

To check operation of the front (1) STOP switch, use a multimeter: when the front brake lever is operated, there must be electric continuity between the terminals of the corresponding switch. No electric continuity should be available when brakes are not operated.

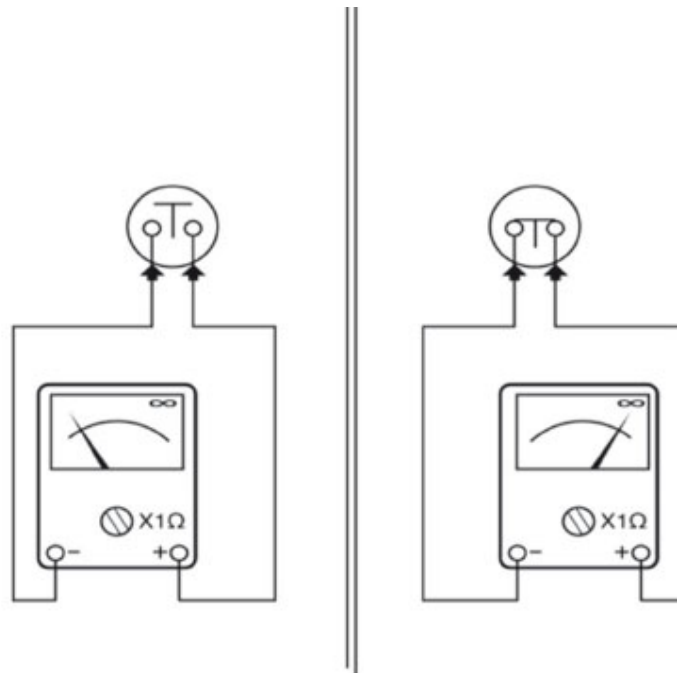

If these tests fail to produce positive results, the part in question must be replaced.

Electric diagram

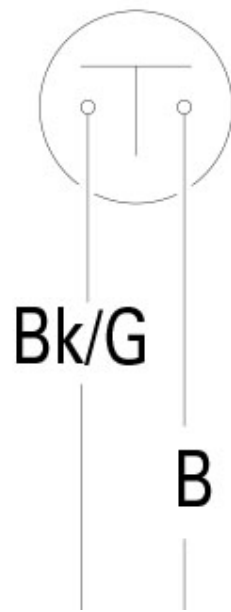

Main relay and injection

To remove and refit the main relay, refer to chapter "[Starting system](#)".

Timing/rpm sensor

The engine rpm sensor (1) is an inductive sensor that detects the teeth of a phonic wheel by means of an alternate signal proportional to the teeth passage speed. The toothed pulley usually features "Xn teeth with a gap of two teeth" as reference for the first cylinder TDC.



Position 1: the pick-up sensor detects the "full area" (i.e. the tooth);
Position 2: the pick-up sensor detects the "empty area" (i.e. the gap between the teeth).

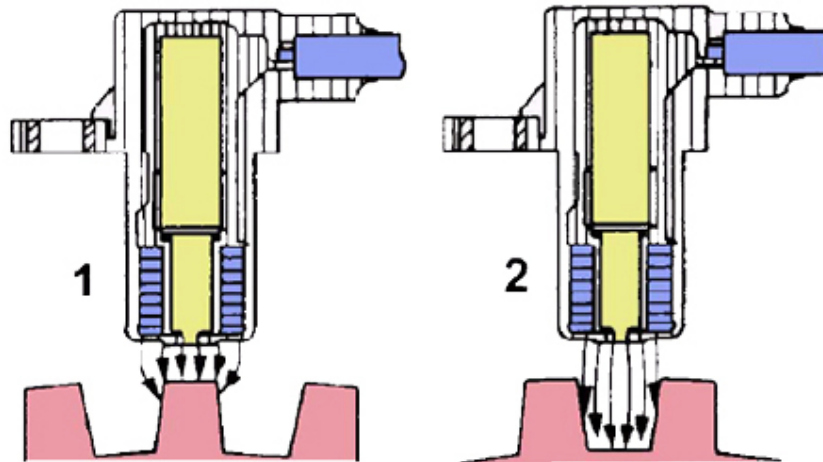

The engine rpm sensor (pick-up sensor) is located on the engine left side.
Connector (2) is located above sensor (1).

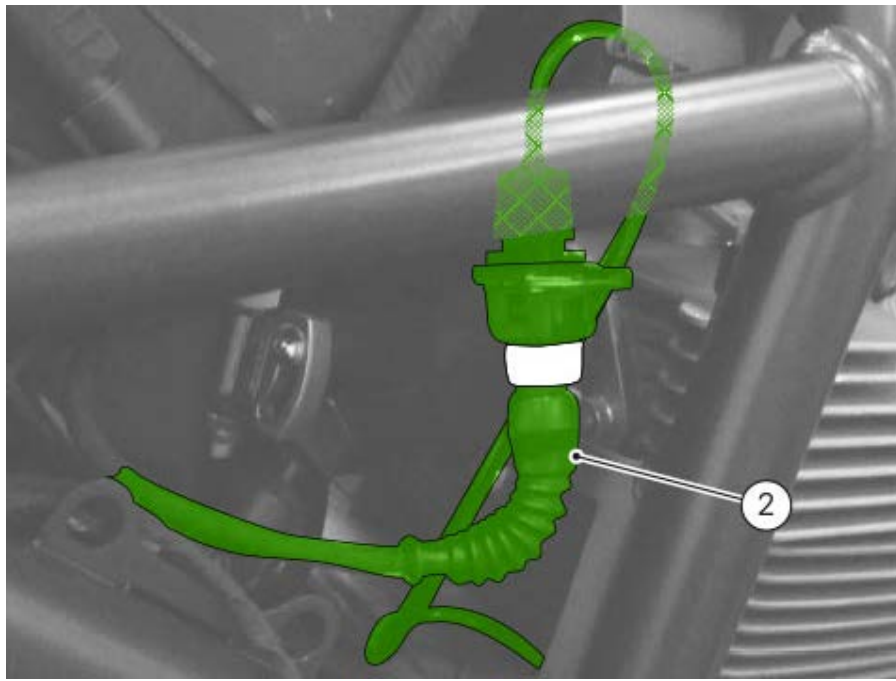

Check for rpm/timing sensor (pick-up) correct operation with the diagnosis instrument DDS 2.

Electric diagram

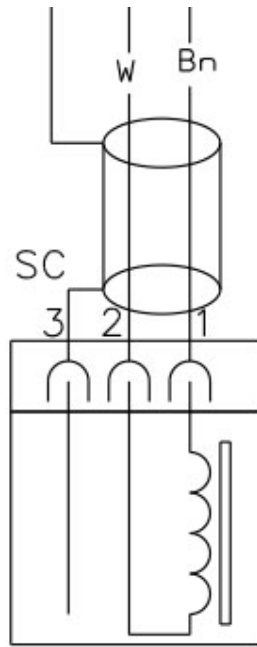

Throttle position potentiometer (TPS)

The TPS (Throttle Position Sensor) (1) is a potentiometer installed on the throttle body. The TPS sends information to the control unit about the exact position of the throttle.

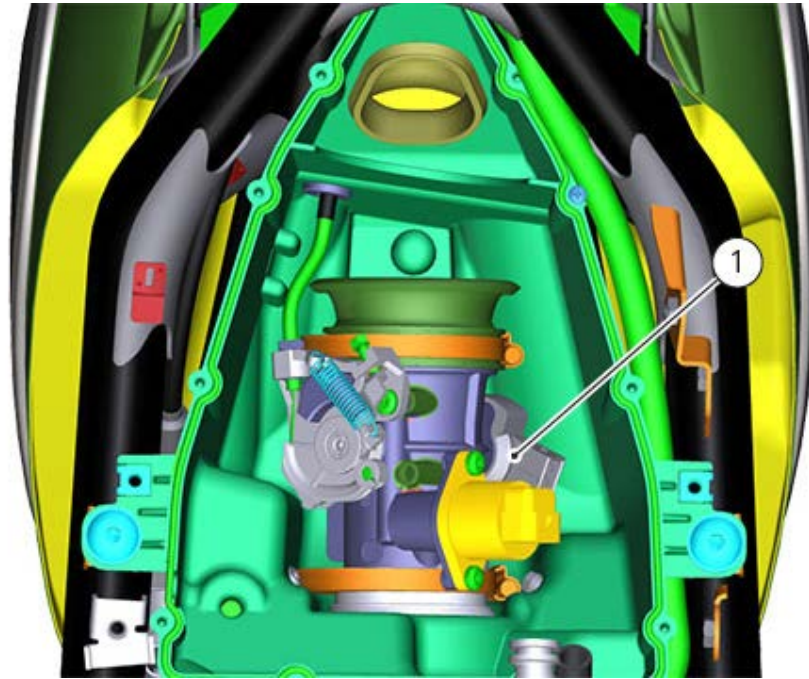

To remove and refit the TPS, refer to chapters "[Removing the airbox and throttle body](#)" and "[Refitting the airbox and throttle body](#)".

Check for TPS correct operation with the diagnosis instrument DDS 2.

TPS electric diagram

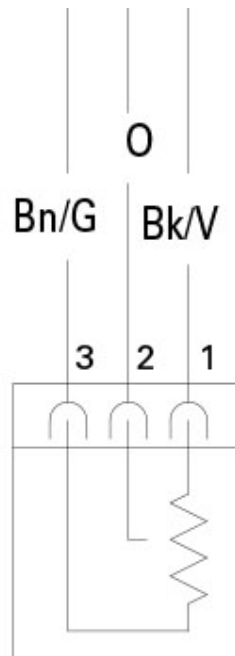

Coil

The ignition coil increases the input voltage of the current alternator and brings the voltage to a value that allows the spark creation in the spark plug.

The vehicle features two coils, one for the horizontal cylinder (1) and another for the vertical cylinder (2), located under the covers (3) and (4).



REMOVAL PROCEDURE

To reach the coils remove covers (3) and (4) after removing screws (5) and (6).



Disconnect connectors (7) and (8) of the horizontal and vertical cylinder coils.



CONTROLS

Check the correct operation with the DDS 2 diagnosis instrument connected to control unit diagnostic socket.

Electric diagram

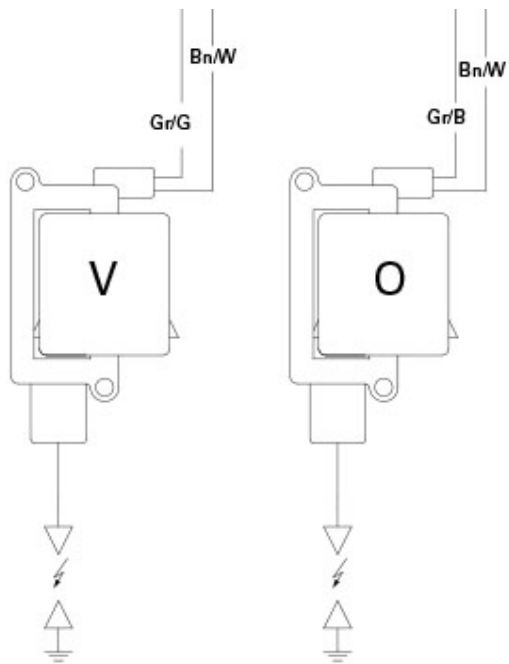

Ignition spark plug

To check the spark plug, refer to chapter "[Replacing the spark plugs](#)".

Temperature sensor

The air temperature sensor (1), located on vehicle central part, detects the ambient temperature. The detected signal is sent to the control unit, that shares it through the CAN line with the instrument panel; this allows performing map corrections if necessary.



Check the operation of sensor (1) using the DDS 2.

After selecting the proper items on the DDS 2 menu, read the external air temperature value among the different displayed parameters and compare it with the actual value. Change the sensor if reading is incorrect.

Electric diagram

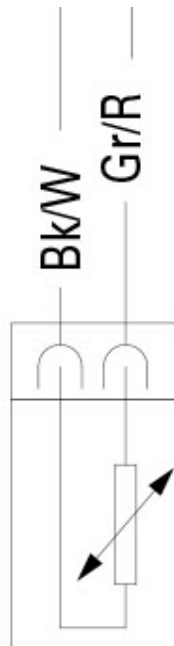

Map Sensor

The Map sensor (Manifold Absolute Pressure) (1) measures the air pressure to calculate the exact quantity of fuel to be injected. The control unit processes the intake air pressure value and the external temperature value to calculate the

quantity of intake air in the cylinders and, based on the preset stoichiometric ratio, determines the correct quantity of fuel to be delivered to the injectors. The air/fuel ratio is therefore always excellent.

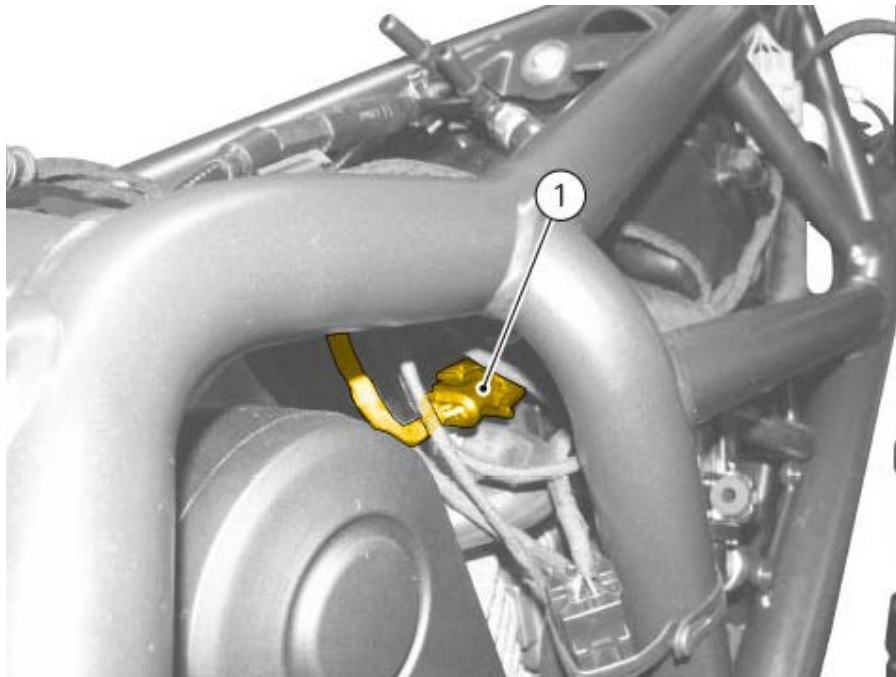

Check the correct operation of MAP sensor (1) using the DDS 2.

Electric diagram

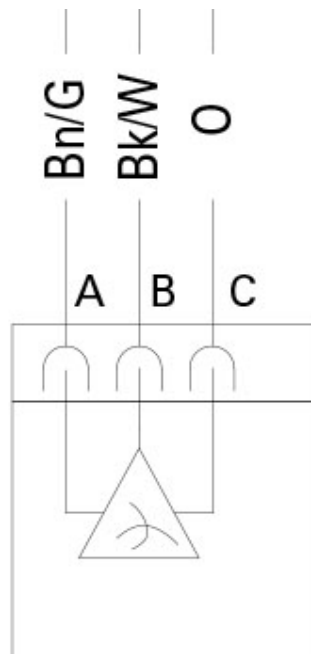

Oil pressure sensor

The oil pressure sensor (pressure switch) (1) is located on the oil cooler.



To test the operation of the engine oil pressure sensor (1), proceed as follows.

Use the diagnosis instrument DDS 2 to check that oil pressure in the engine lubrication circuit complies with the specified values.

If the engine oil pressure value is outside the specified range, check the lubrication circuit components and service as necessary.

Switch on the instrument panel (ignition key turned to ON) without starting the engine, disconnect the electrical terminal from the pressure sensor and connect it to ground:

- if the warning light does not illuminate, this means the sensor is defective and must be replaced;
- if the warning light illuminates, start the engine;
- if the warning light does not turn off, check the system with the DDS 2.

Electric diagram

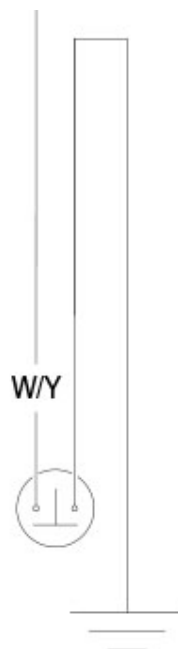

Lambda sensor

The lambda sensor detects the presence of unburned fuel in the exhaust gases, processes the information sent to the control unit and allows keeping the mixture ratio (air kg/fuel kg) within the best efficiency range for the catalytic converter.

The vehicle is provided with two lambda sensors, one per cylinder:

- lambda sensor (1) for horizontal cylinder exhaust;
- lambda sensor (2) for vertical cylinder exhaust.

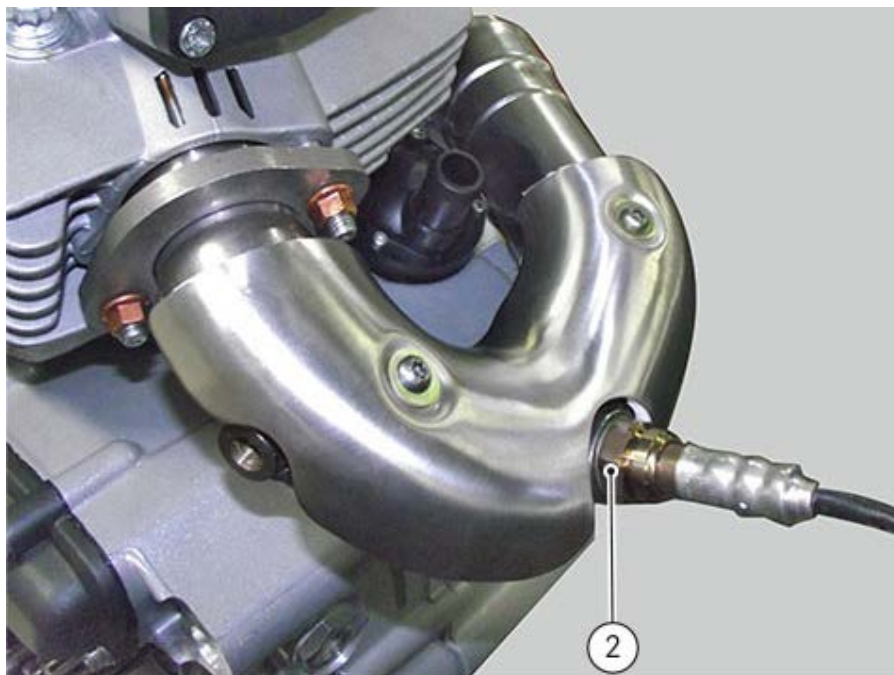

If it is necessary to reach the lambda sensor connectors, consider that:

- connector (3) of the horizontal cylinder lambda sensor is located on the vehicle front and lower side;
- connector (4) of vertical cylinder lambda sensor.

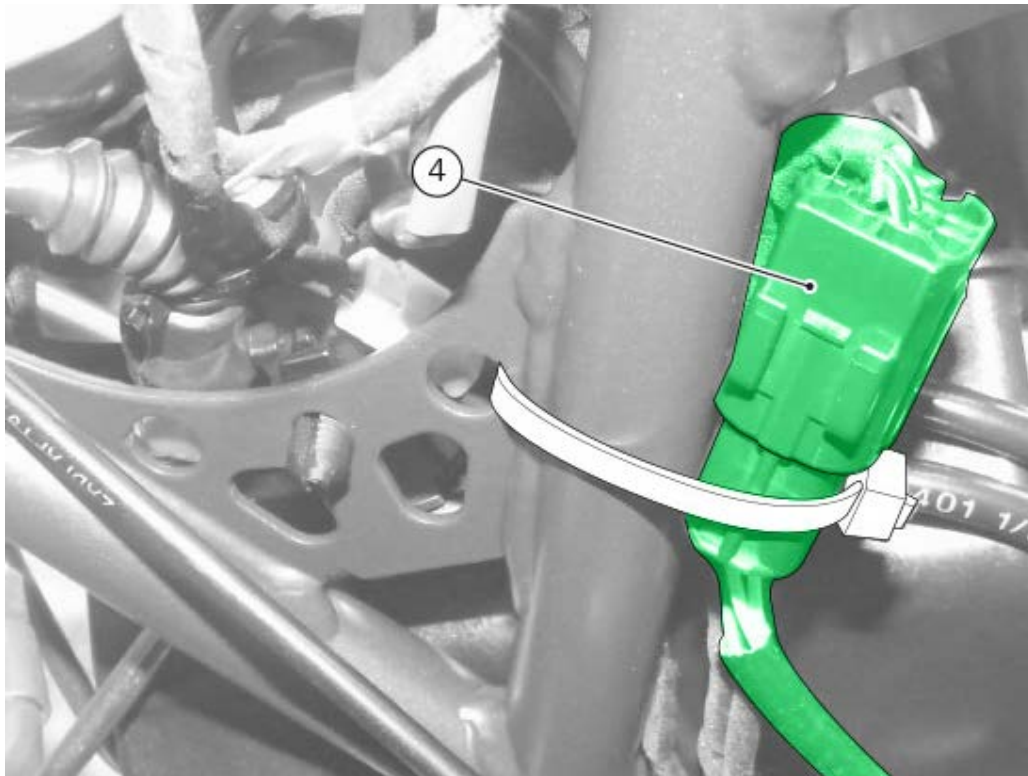
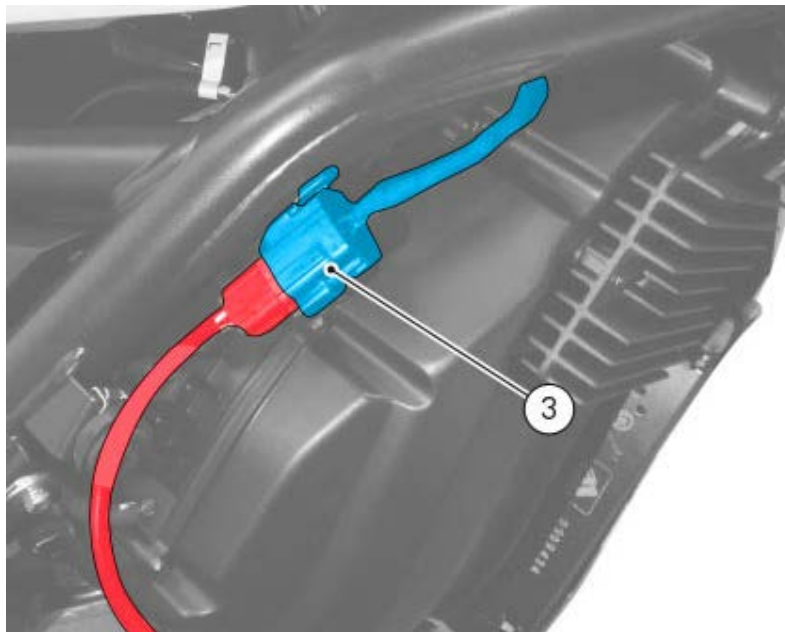

Check lambda sensors correct operation with the DDS 2 diagnosis instrument connected to control unit diagnostic socket.

Electric diagram

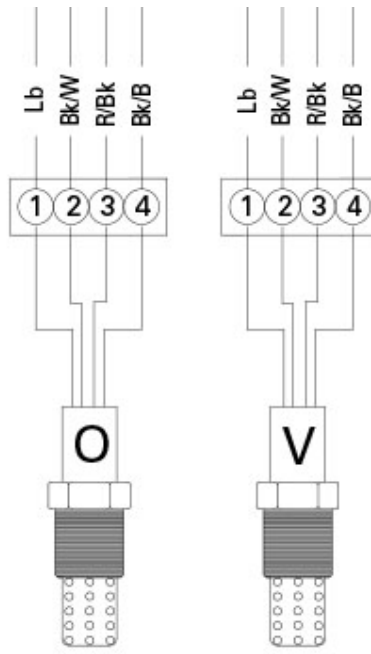

Stepper motor

The stepper motor is useful when the engine does not reach a correct temperature.
The stepper motor works on the throttle valve opening/closing.

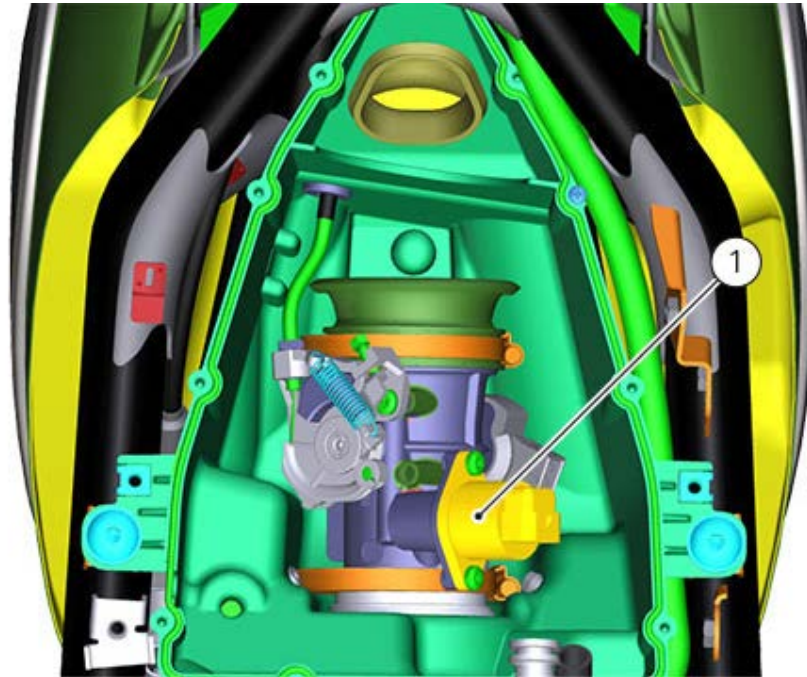

To remove and refit the stepper motor, refer to chapters "[Removing the airbox and throttle body](#)" and "[Refitting the airbox and throttle body](#)".

Check for stepper motor correct operation with the diagnosis instrument DDS 2.

Electric injector

To remove/refit the injector, refer to chapters "[Removing the throttle body](#)" and "[Refitting the throttle body](#)".

Electronic control unit

The engine control unit (1) is an electronic digital microprocessor-based unit.

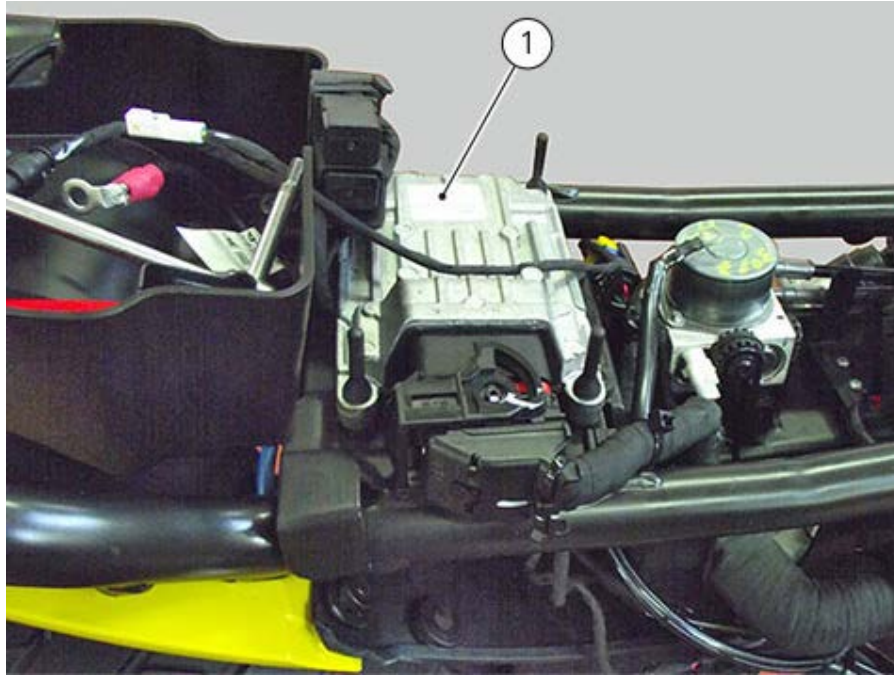

The ECU control unit (1) controls both the injectors and the coils, thus controlling fuel injection and ignition in accordance with the engine operating conditions detected by the following sensors:

- absolute pressure sensor (measures the barometric pressure);
- air temperature sensor (measures intake air temperature);
- engine temperature sensor (measures the coolant temperature);
- timing/rpm sensor (for engine rotation speed and the position of each cylinder relative to TDC);
- throttle position sensor (measures the throttle opening angle).

The ECU also monitors battery voltage so that it can adjust injector opening time and ignition coil charging time accordingly.

The ECU determines the following values:

- quantity of fuel delivered to each cylinder;
- injector closing time and therefore injection timing relative to the end of the intake stroke for each cylinder;
- spark advance.

Important

The maps, which include spark advance values, injection times, crankshaft angle for injector closing and all correction curves as a function of temperature and atmospheric pressure values, are stored in the Flash Eprom of the ECU. The above values are preset by the Manufacturer after testing the motorcycle under different riding conditions. These settings cannot be changed.

REMOVAL/REASSEMBLY

Remove the seat ([Removing the seat](#))

Disconnect connector (2) of the control unit (1). Remove the control unit (1) by sliding it off pins (3).

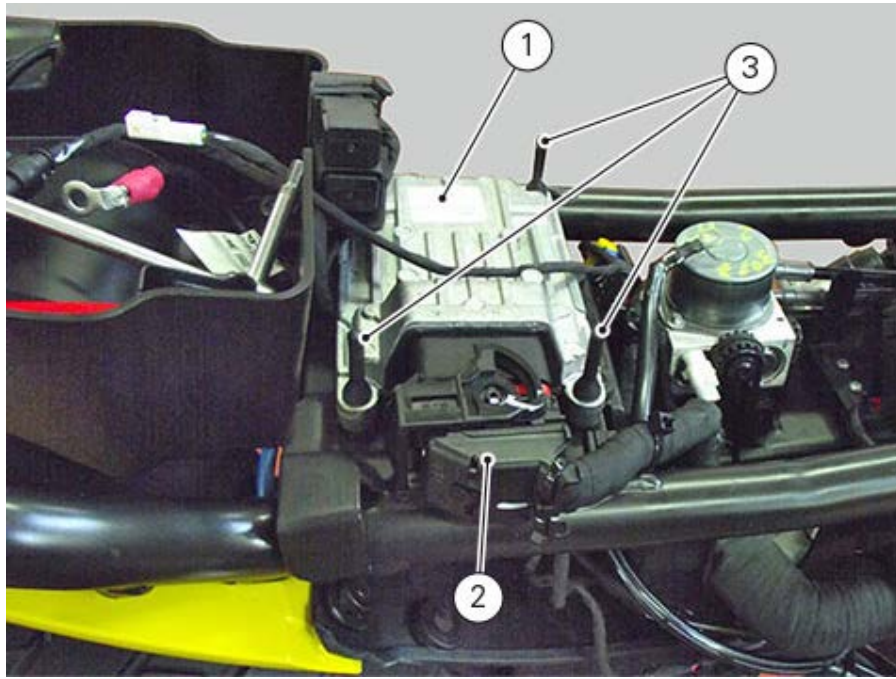

Refit control unit (1) by engaging it on pins (3), ensuring it is properly in seat. Connect connector (2).

Refit the seat ([Refitting the seat](#)).

Overhauling the front wheel

Wheel bearings

Before checking the dimensions, check for wear on wheel hub bearings. Check for wear by hand after cleaning and degreasing the bearings in their seats.

Turn the internal ring and check that the internal balls move freely: any irregularity indicates deformations like those indicated in values "A" and "B".

An excessive wear can cause vibrations and instability of the vehicle and therefore it is necessary to replace them.

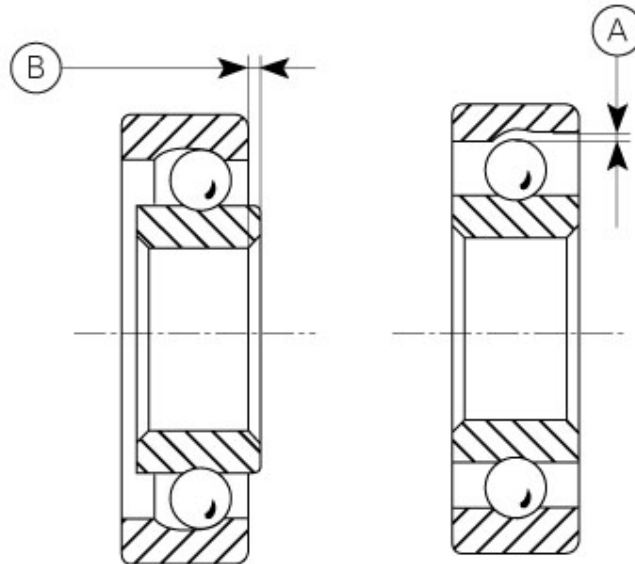

To remove the bearings and the sealing rings from the wheel hub follow the instructions below.

Position a drift (C) against the inner ring of the bearing (10).

Tap with a hammer until removing the bearing (10).

Apply the drift at different points to facilitate the removal.

Important

Once removed, the used bearings and sealing rings must not be refitted.

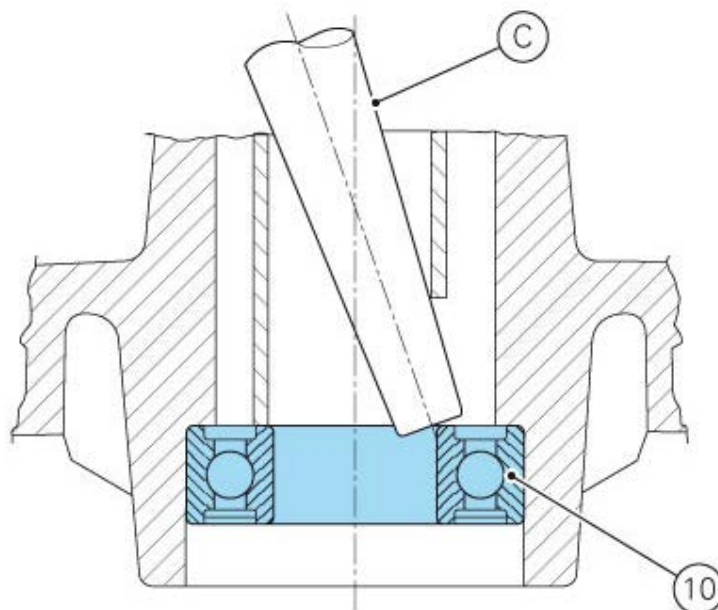

Before fitting new bearings, check that the seat is clean and free from scoring and damage. Grease the bearing seat and then push the new bearing into its seat. Using a tubular drift (D) that only bears on the outer ring of the bearing (10) to drive the latter fully into its seat.

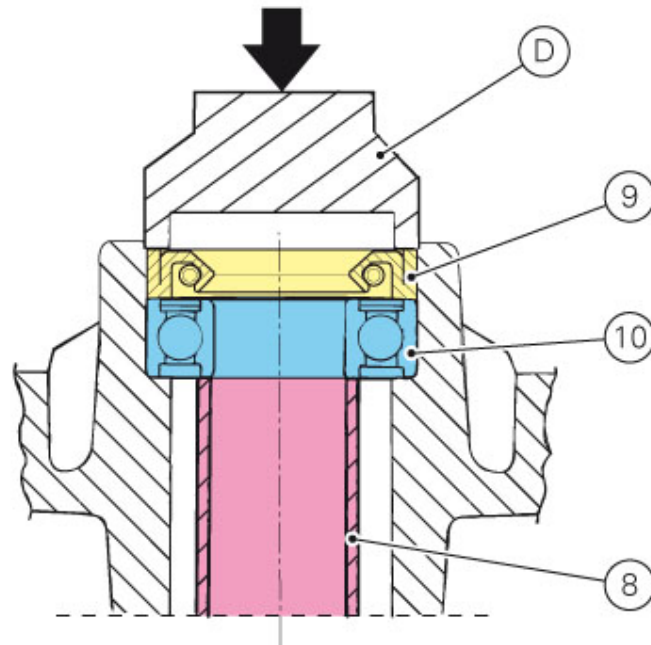

Use the same method to install the sealing rings (9). Ensure that spacer (8) is fitted between the two wheel hub bearings.

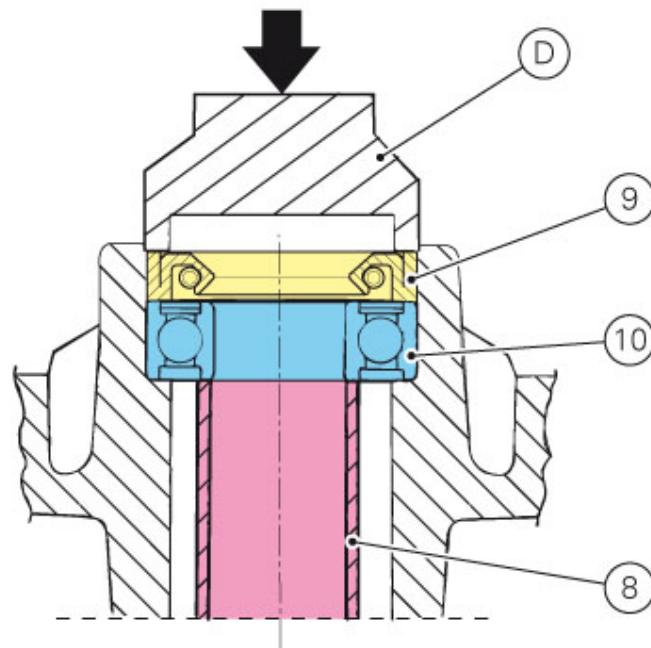

Note

Wheels must be rebalanced after repair, maintenance and overhaul operations.

Inspecting the wheel shaft

For the check values refer to paragraph ([Front Wheel](#)).

Check the wheel shaft (7) for straightness. Turn the shaft on a reference surface and measure maximum distortion using a feeler gauge.

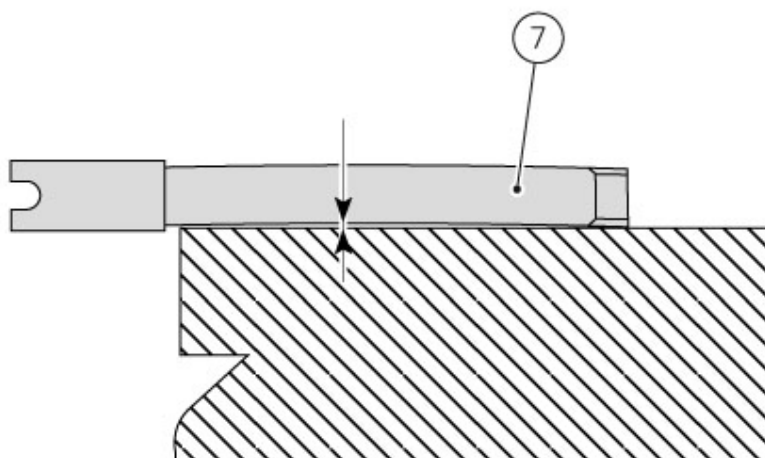

Overhauling the front wheel rim, spokes and nipples

Perform a visual check for damaged parts: if no components are damaged check the nipple tightening and axial and radial runout, as described below.

In case of runout, replace the rim.

In case of broken spokes replace them as described below: if three or more spokes broken at the same time, it is necessary to check all spokes since such a high number of broken spokes not due to critical events could mean that they were faulty and/or the installation/maintenance were not performed correctly. Check for not spokes emitting a hollow sound when hit with a metallic object: this could mean that there are loosen spokes that have been used for a long time without preload: in this case, check the threaded coupling to the nipple and the seat in the spoke head hub.

Checking the nipple minimum tightening torque

This operation can be performed also with wheel fitted on the motorcycle, by lifting it from the ground and ensuring it can rotate freely.

Starting from the valve hole as reference point, no matter if clockwise or counter clockwise, check the minimum tightening torque of all nipples (11) once and one after the other and stop at the valve hole: the minimum torque must be 4 Nm. The wrench to be used is tool (A) no. **88713.2776**.

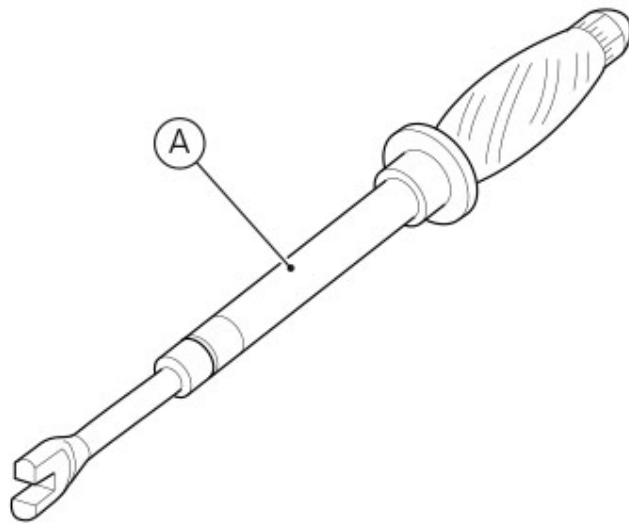
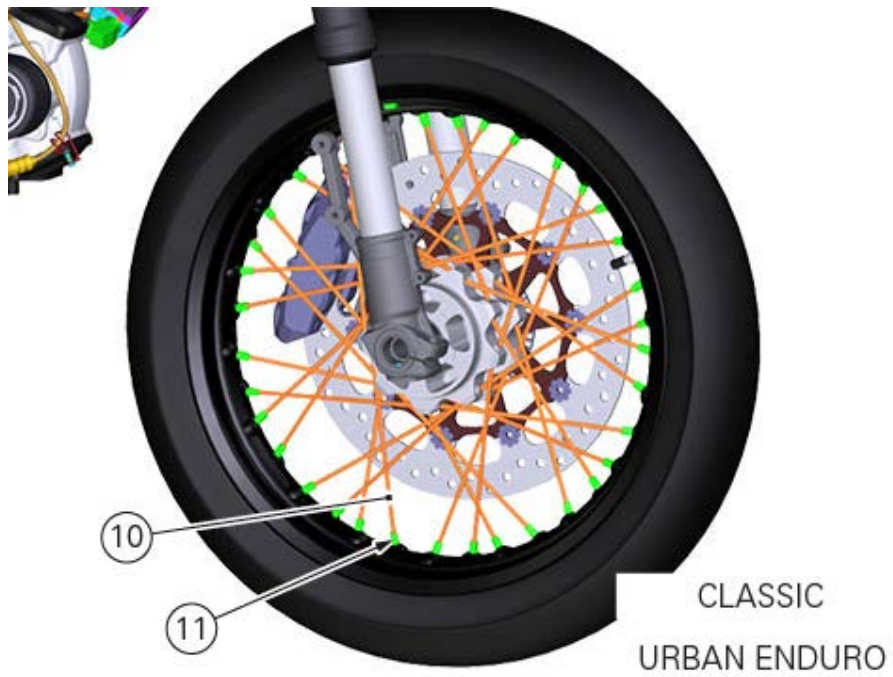

Check that none of spokes (10) emits a hollow sound when hit with a metallic object: this to avoid that seizure or oxidation of spoke and nipple coupling cancels the action of the applied torque; if necessary, restore the correct coupling ensuring not to use products that are aggressive for the wall and the tube.

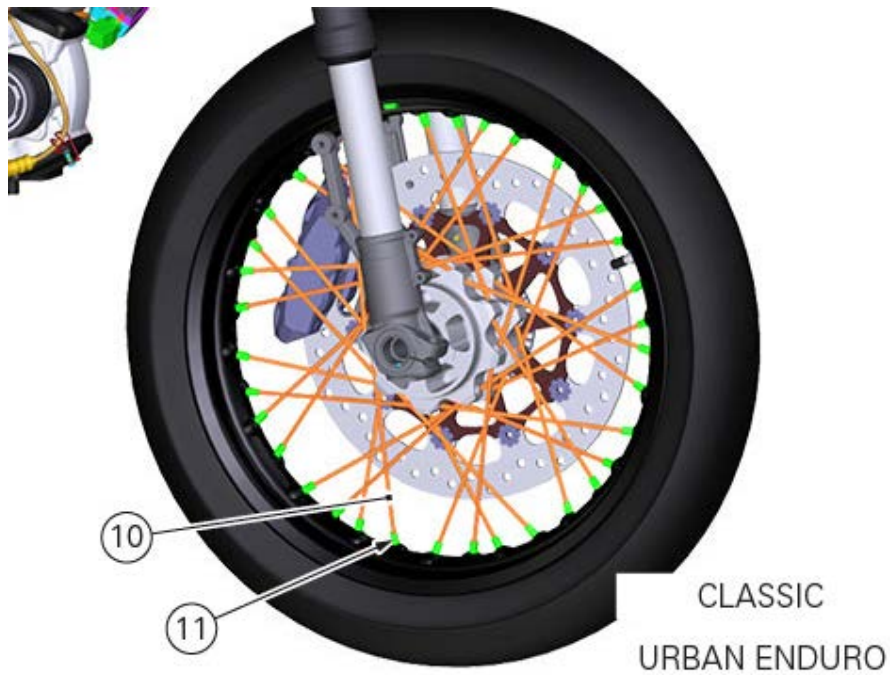

Checking for radial or axial runout

This operation can be performed by positioning the wheel on the centring tool (B) no. 88713.2775 or leaving it fitted on the vehicle, by lifting it from the ground and using a support with dial gauges.

Check that the reference elements (C) of centring tool (B) no. 88713.2775 or the dial gauges are at right angle to the surface to check: for the axial runout, use the outer side of rim (D), and for the radial runout use the internal surfaced of the rim without nipples (E).

While the wheel is rotating, measure the runout values: reset the gauge on the rim and check the movement by inserting a feeler gauge in the gap between reference point and rim.

The axial and radial runout values must be equal to or lower than **0.8** mm and with a max. use limit of **2** mm: once this limit is reached, it is necessary to perform another regulation.

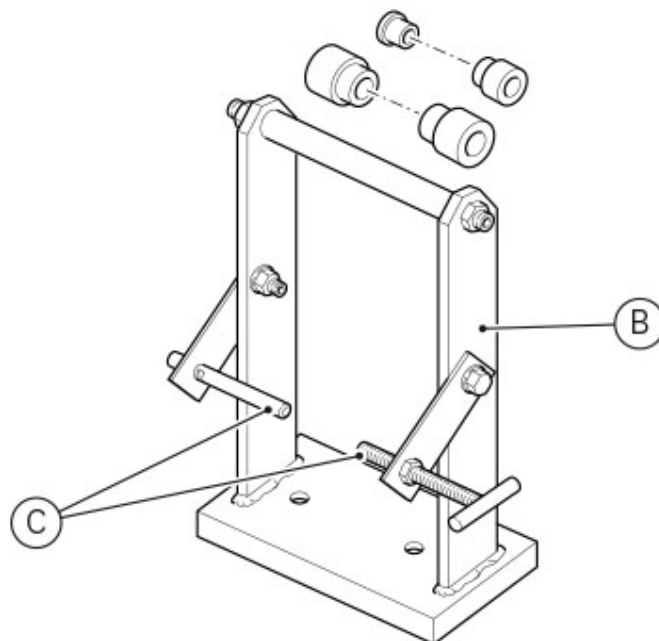

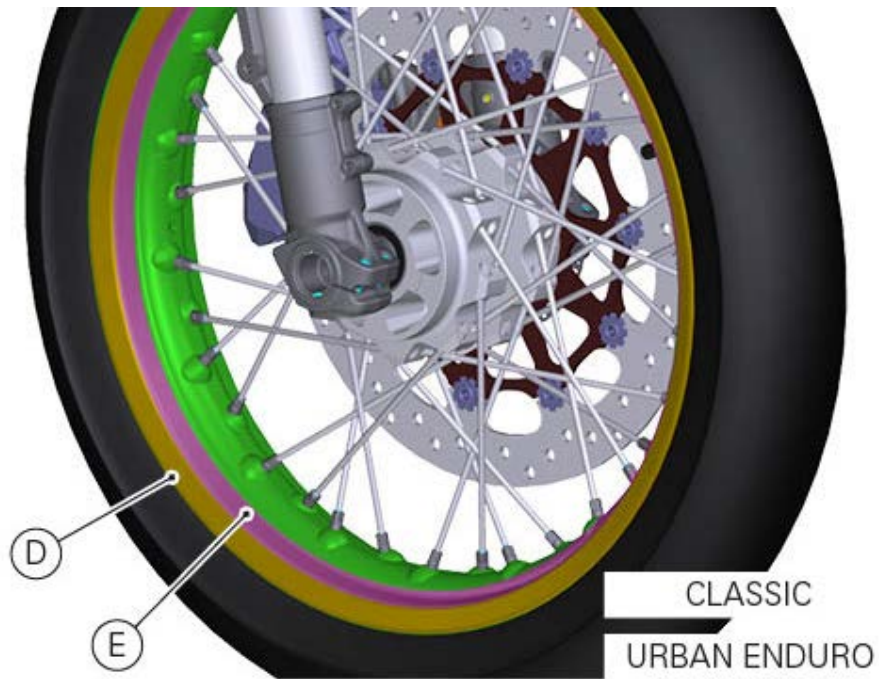

Changing the spokes

Remove the tyre, the tube and the nipple protection cover from the rim and position the wheel on the centring tool (B) no. **88713.2775**.



Note

To perform these operations easily it may be necessary to remove the brake disc and loosen the other spokes.

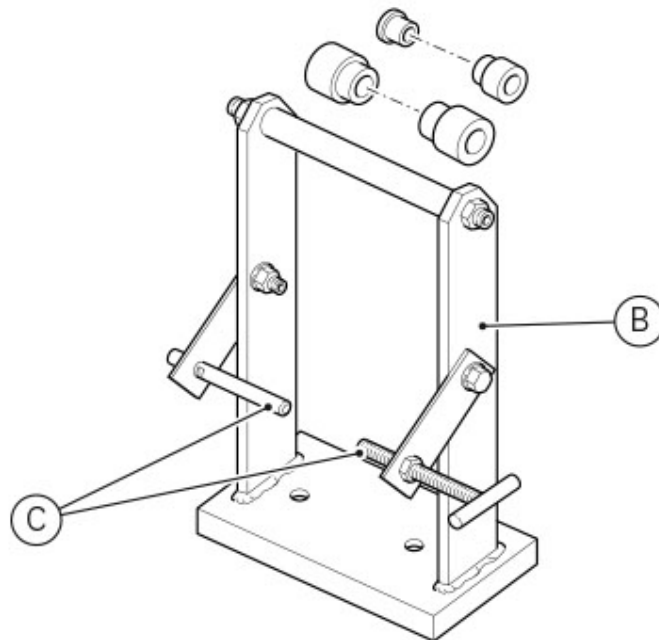

Unscrew nipple (11) and remove the damaged spoke (10) by sliding it off the seat in the hub.

Insert the new spoke in the seat of the hub and screw a new nipple (11) and tightening it to a minimum torque of 4 Nm with a wrench (A) no. **88713.2776**.

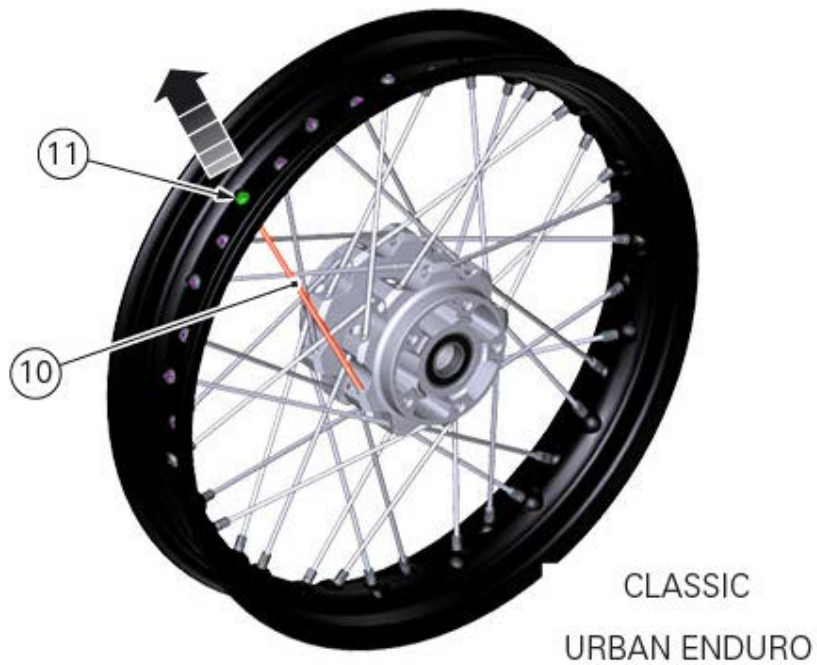

Then check the lateral and axial runout as already described before.

Tensioning and centring operation

Remove the tyre and the tube from the rim and position the wheel on the centring tool (B) no. 88713.2775 using suitable spacers (F).

Block the wheel pack checking for no end float.

Check the rim axial and radial runout, as described before.

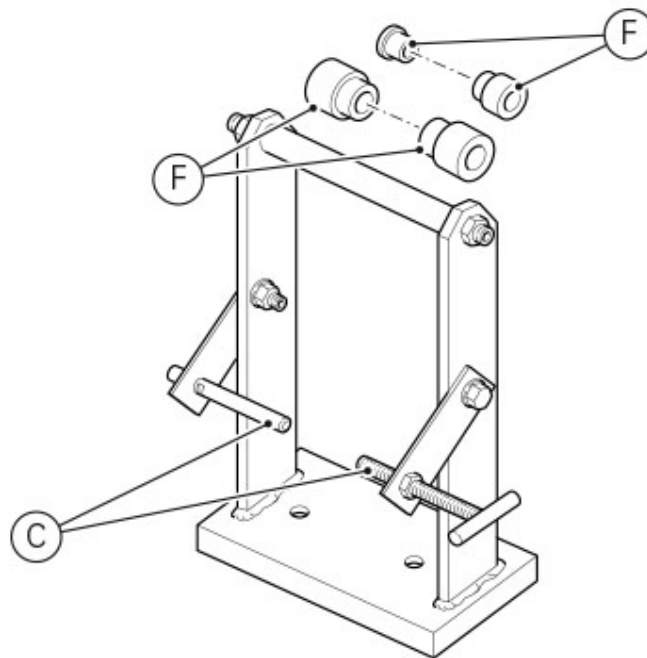

Rotate the rim: if the detected values do not fall within the specified ranges, tension or loosen the spokes using the centring tool (G) no. **88713.2777** on the polygonal side of nipples (11).

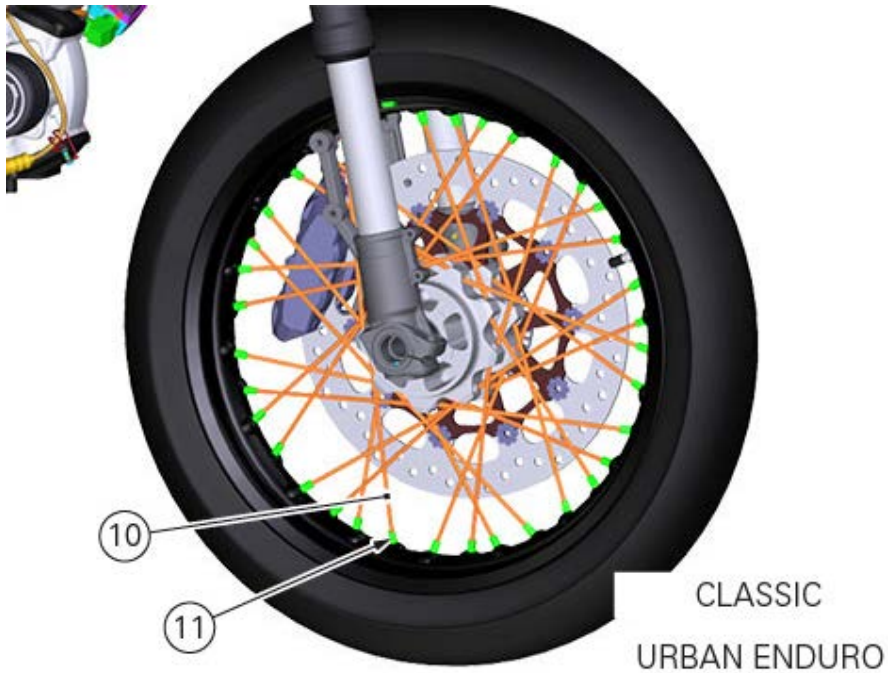
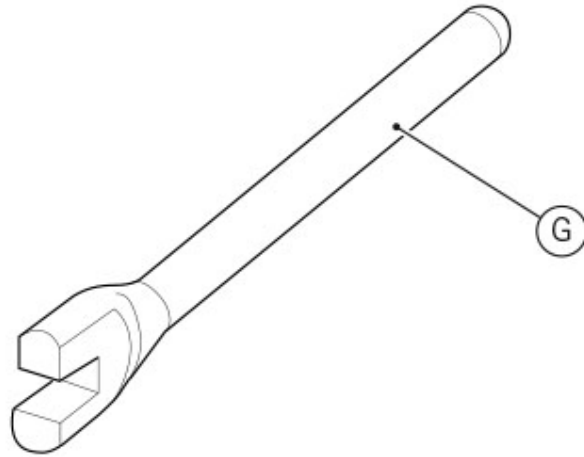

In case of axial runout, tension the spokes on the side featuring a value increase and loosen those on the opposite side. Always work on several spokes, at least on two spokes per side, by letting them perform small rotations between one check and the following one.
 In case of radial runout, loosen the rim spokes featuring a value increase and tension those on the opposite side. Check the axial runout again as described above.

Loosen the wheel pack, invert its installation sense and tighten it to check the axial and radial runout and camber on the other side:

- fix the axial runout reference to check the correct camber: symmetric for the front wheel and ensured by the suitable spacers for the rear wheel;
- fix the radial runout reference to check the rim shoulder that has not been checked before.

Repeat the checks and operate until reaching the specified value of 0.8 mm.
 Tighten nipples (11) to a minimum torque of 4 Nm.

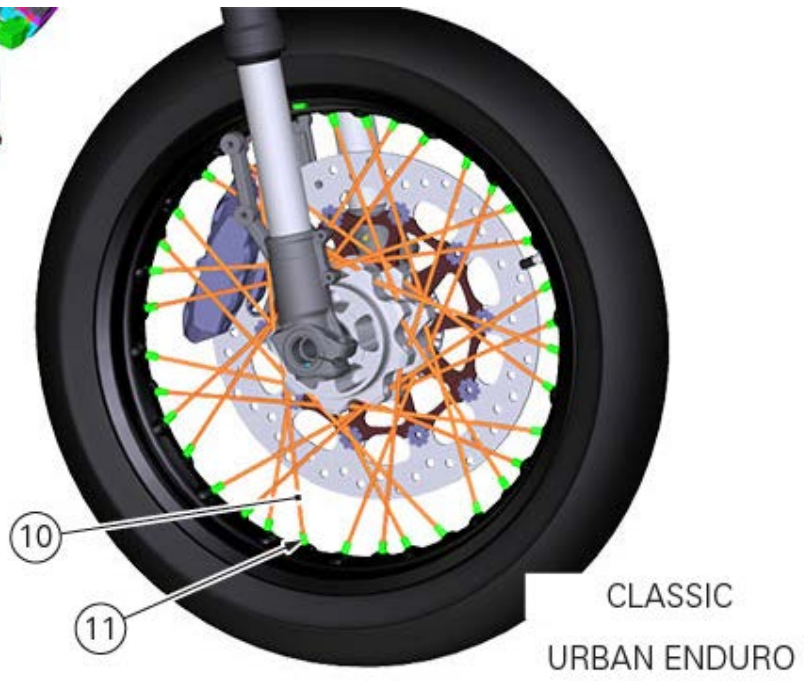

Overhauling the front wheel

Wheel bearings

Before checking the dimensions, check for wear on wheel hub bearings. Check for wear by hand after cleaning and degreasing the bearings in their seats.

Turn the internal ring and check that the internal balls move freely: any irregularity indicates deformations like those indicated in values "A" and "B".

An excessive wear can cause vibrations and instability of the vehicle and therefore it is necessary to replace them.

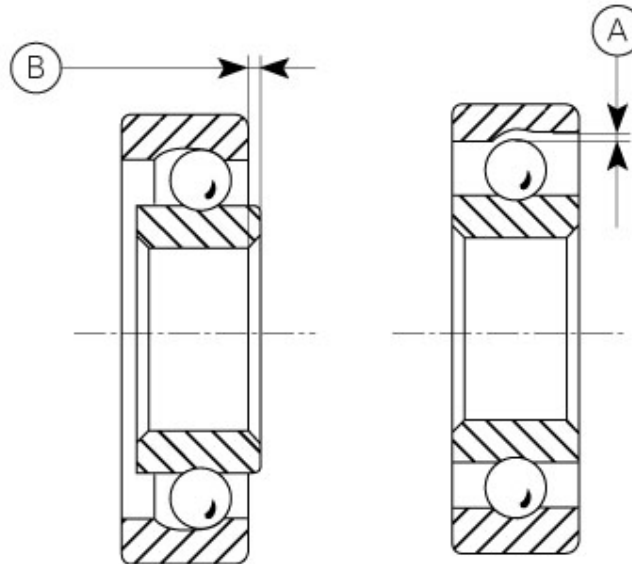

To remove the bearings and the sealing rings from the wheel hub follow the instructions below.

Position a drift (C) against the inner ring of the bearing (10).

Tap with a hammer until removing the bearing (10).

Apply the drift at different points to facilitate the removal.

Important

Once removed, the used bearings and sealing rings must not be refitted.

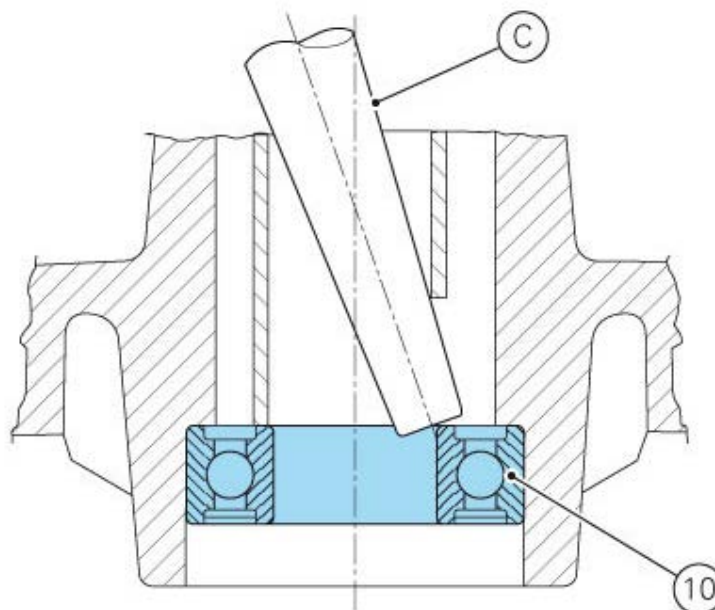

Before fitting new bearings, check that the seat is clean and free from scoring and damage. Grease the bearing seat and then push the new bearing into its seat. Using a tubular drift (D) that only bears on the outer ring of the bearing (10) to drive the latter fully into its seat.

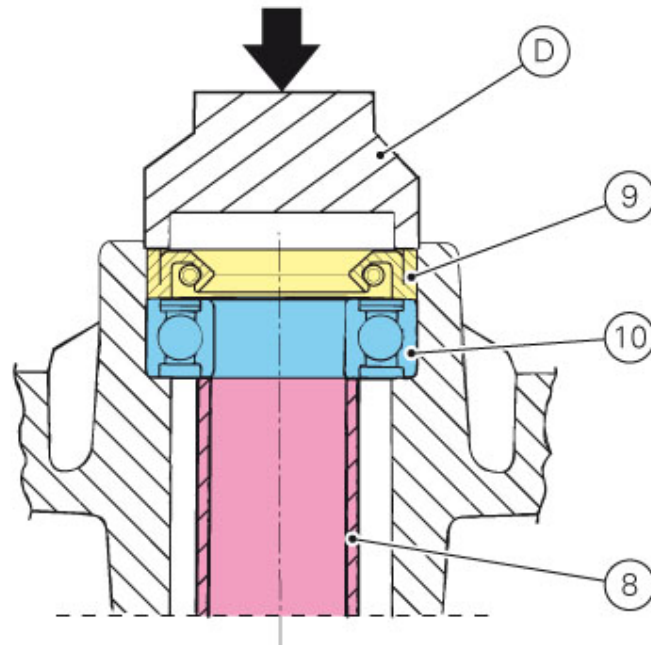

Use the same method to install the sealing rings (9). Ensure that spacer (8) is fitted between the two wheel hub bearings.

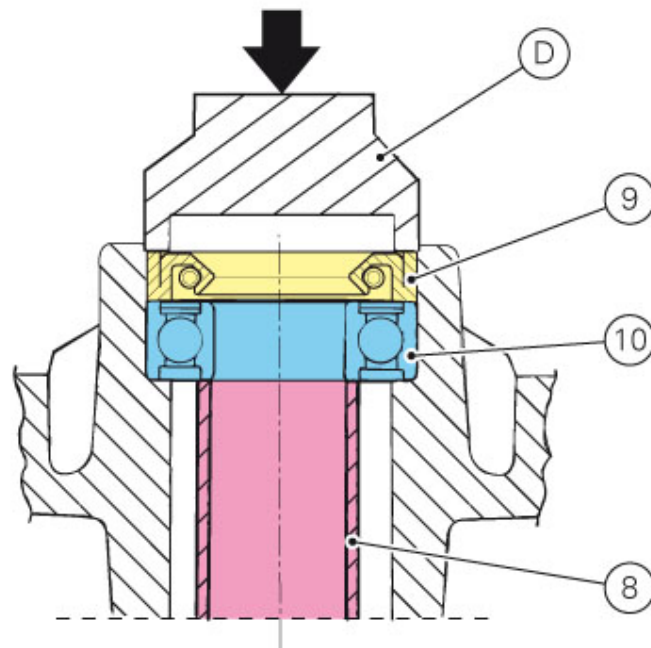

Note

Wheels must be rebalanced after repair, maintenance and overhaul operations.

Inspecting the wheel shaft

For the check values refer to paragraph ([Front Wheel](#)).

Check the wheel shaft (7) for straightness. Turn the shaft on a reference surface and measure maximum distortion using a feeler gauge.

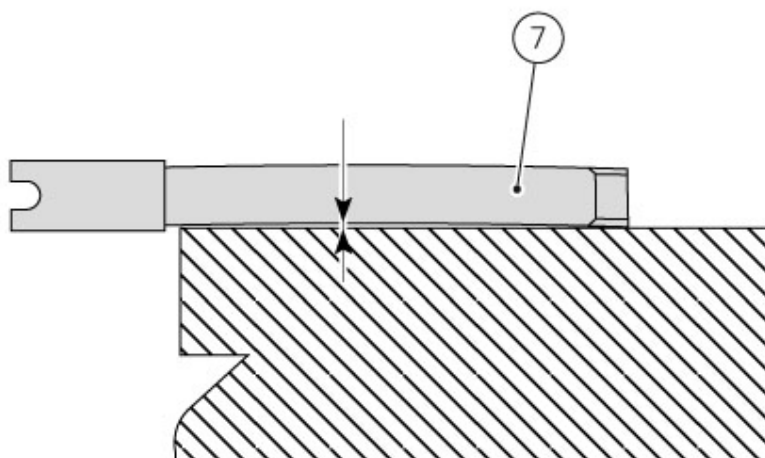

Overhauling the front wheel rim, spokes and nipples

Perform a visual check for damaged parts: if no components are damaged check the nipple tightening and axial and radial runout, as described below.

In case of runout, replace the rim.

In case of broken spokes replace them as described below: if three or more spokes broken at the same time, it is necessary to check all spokes since such a high number of broken spokes not due to critical events could mean that they were faulty and/or the installation/maintenance were not performed correctly. Check for not spokes emitting a hollow sound when hit with a metallic object: this could mean that there are loosen spokes that have been used for a long time without preload: in this case, check the threaded coupling to the nipple and the seat in the spoke head hub.

Checking the nipple minimum tightening torque

This operation can be performed also with wheel fitted on the motorcycle, by lifting it from the ground and ensuring it can rotate freely.

Starting from the valve hole as reference point, no matter if clockwise or counter clockwise, check the minimum tightening torque of all nipples (11) once and one after the other and stop at the valve hole: the minimum torque must be 4 Nm. The wrench to be used is tool (A) no. **88713.2776**.

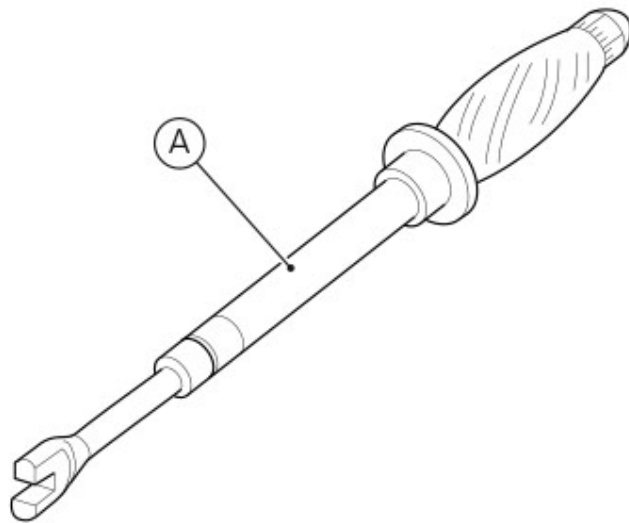
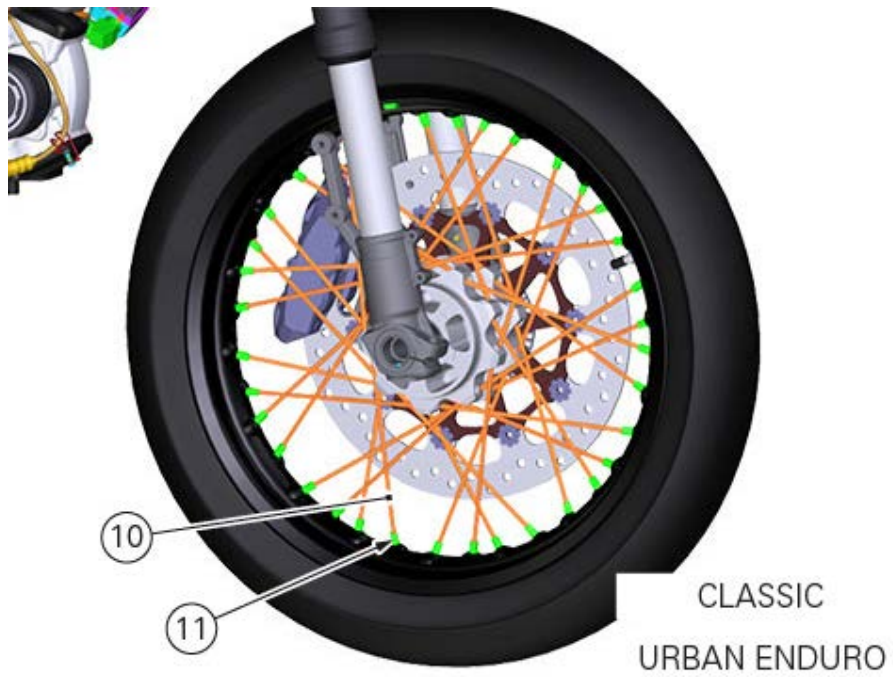

Check that none of spokes (10) emits a hollow sound when hit with a metallic object: this to avoid that seizure or oxidation of spoke and nipple coupling cancels the action of the applied torque; if necessary, restore the correct coupling ensuring not to use products that are aggressive for the wall and the tube.

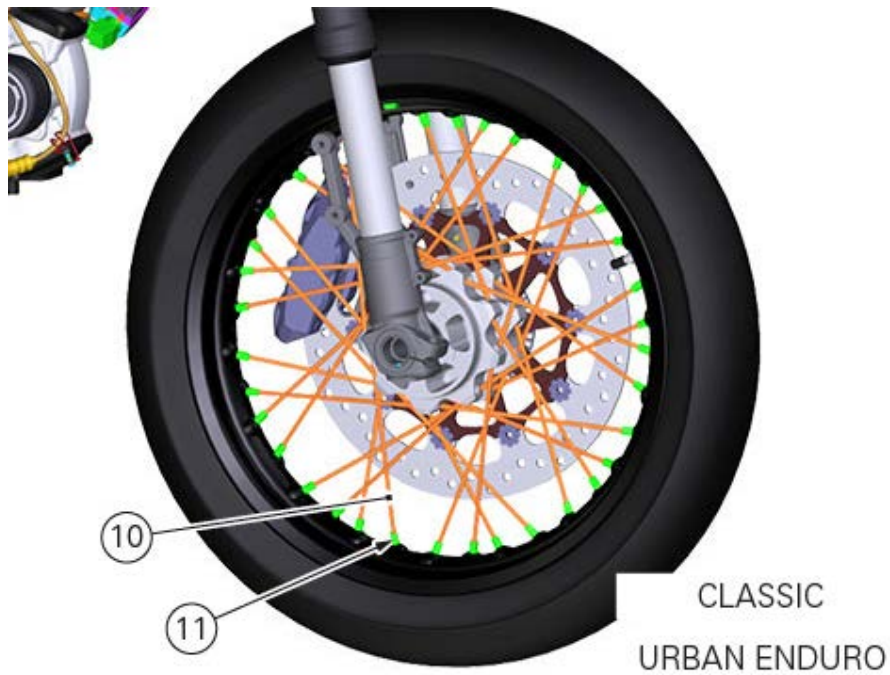

Checking for radial or axial runout

This operation can be performed by positioning the wheel on the centring tool (B) no. 88713.2775 or leaving it fitted on the vehicle, by lifting it from the ground and using a support with dial gauges.

Check that the reference elements (C) of centring tool (B) no. 88713.2775 or the dial gauges are at right angle to the surface to check: for the axial runout, use the outer side of rim (D), and for the radial runout use the internal surfaced of the rim without nipples (E).

While the wheel is rotating, measure the runout values: reset the gauge on the rim and check the movement by inserting a feeler gauge in the gap between reference point and rim.

The axial and radial runout values must be equal to or lower than **0.8** mm and with a max. use limit of **2** mm: once this limit is reached, it is necessary to perform another regulation.

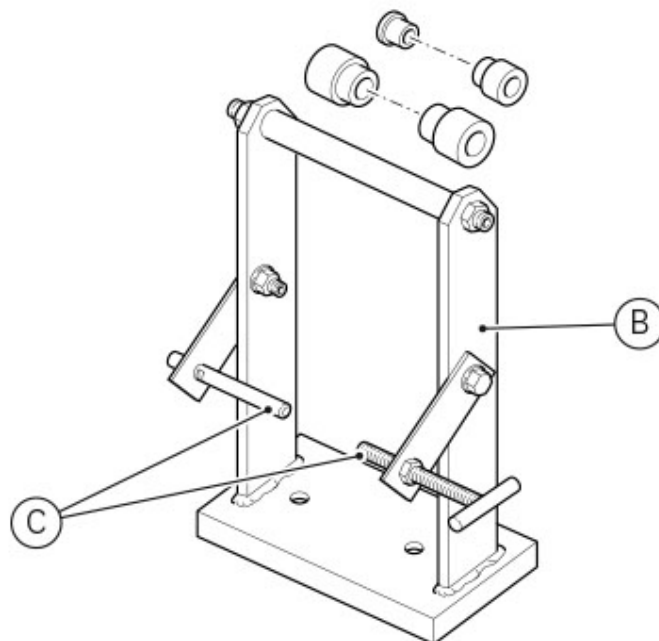

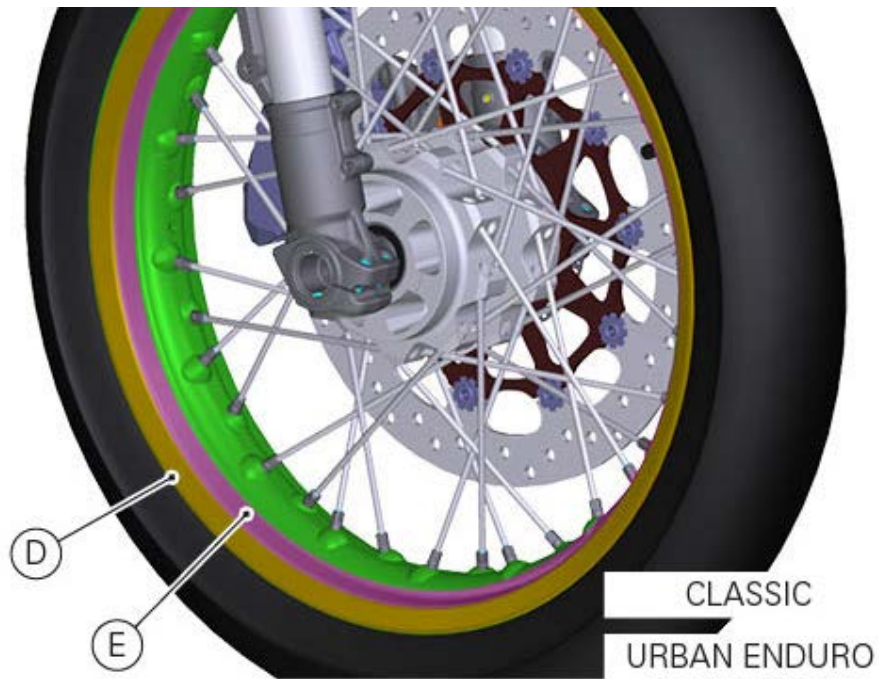

Changing the spokes

Remove the tyre, the tube and the nipple protection cover from the rim and position the wheel on the centring tool (B) no. **88713.2775**.



Note

To perform these operations easily it may be necessary to remove the brake disc and loosen the other spokes.

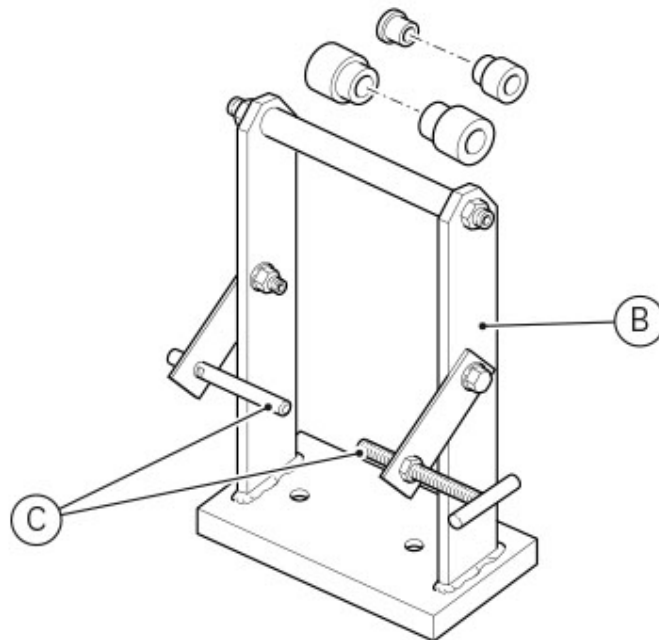

Unscrew nipple (11) and remove the damaged spoke (10) by sliding it off the seat in the hub.

Insert the new spoke in the seat of the hub and screw a new nipple (11) and tightening it to a minimum torque of 4 Nm with a wrench (A) no. **88713.2776**.

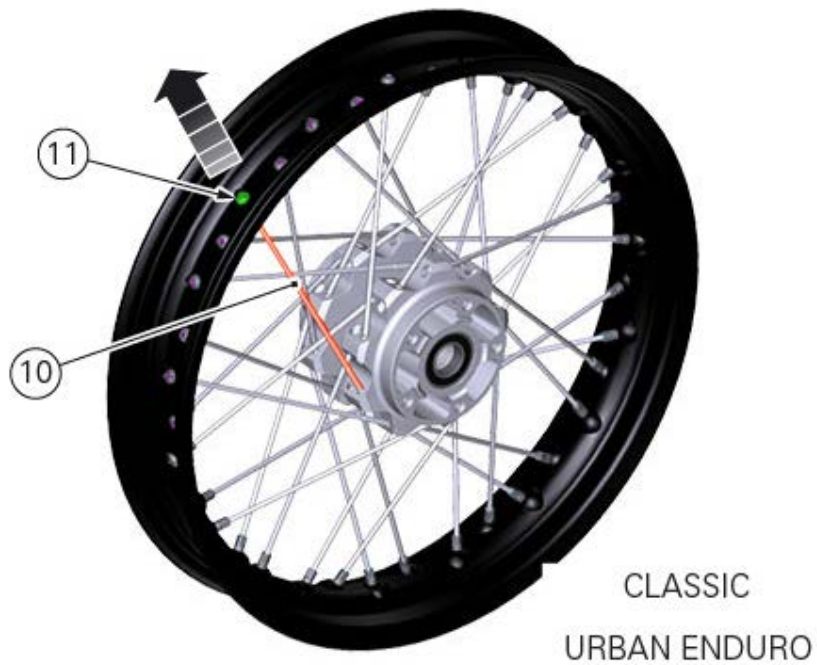

Then check the lateral and axial runout as already described before.

Tensioning and centring operation

Remove the tyre and the tube from the rim and position the wheel on the centring tool (B) no. 88713.2775 using suitable spacers (F).

Block the wheel pack checking for no end float.

Check the rim axial and radial runout, as described before.

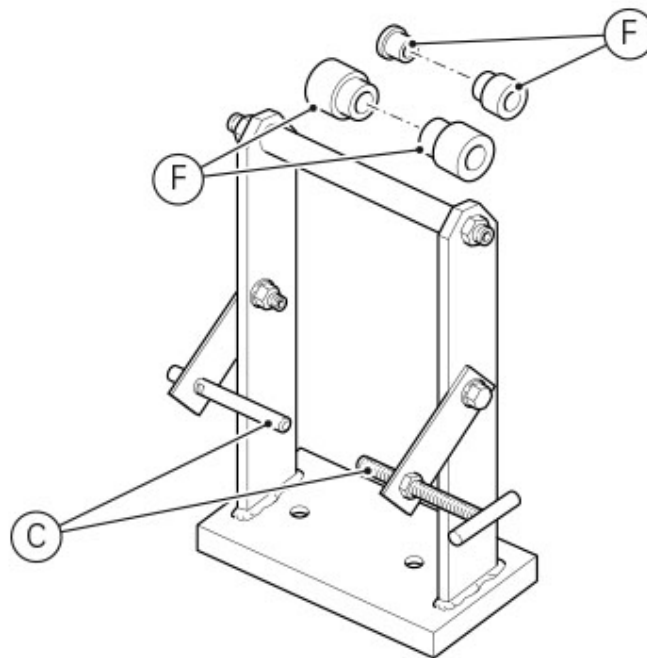

Rotate the rim: if the detected values do not fall within the specified ranges, tension or loosen the spokes using the centring tool (G) no. **88713.2777** on the polygonal side of nipples (11).

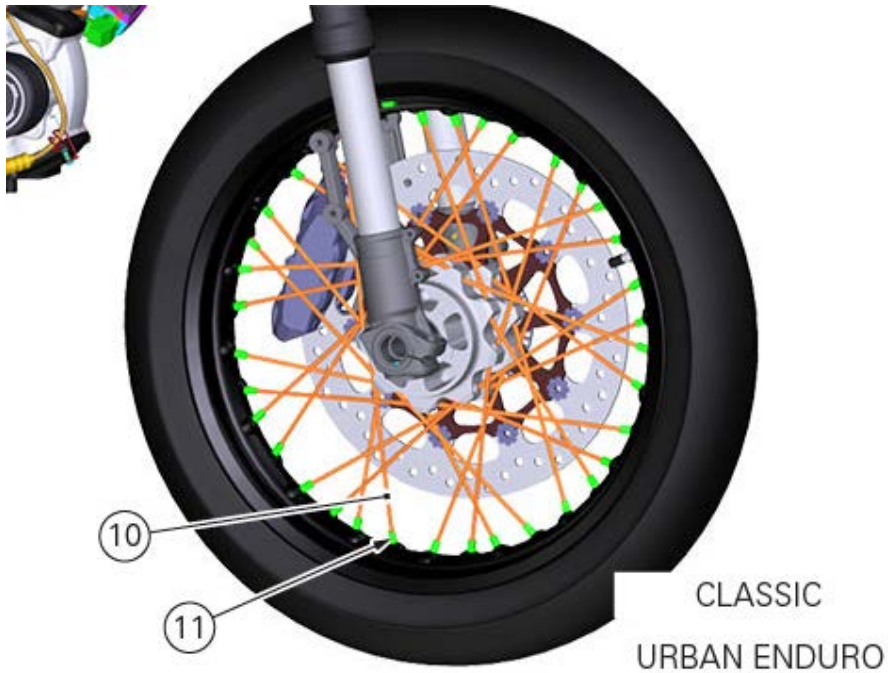
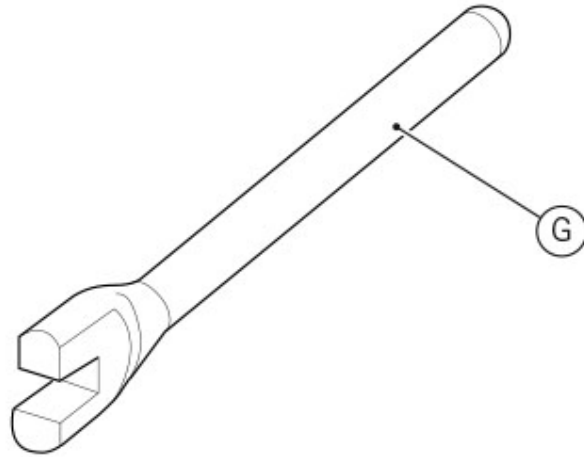

In case of axial runout, tension the spokes on the side featuring a value increase and loosen those on the opposite side. Always work on several spokes, at least on two spokes per side, by letting them perform small rotations between one check and the following one.
 In case of radial runout, loosen the rim spokes featuring a value increase and tension those on the opposite side. Check the axial runout again as described above.

Loosen the wheel pack, invert its installation sense and tighten it to check the axial and radial runout and camber on the other side:

- fix the axial runout reference to check the correct camber: symmetric for the front wheel and ensured by the suitable spacers for the rear wheel;
- fix the radial runout reference to check the rim shoulder that has not been checked before.

Repeat the checks and operate until reaching the specified value of 0.8 mm.
 Tighten nipples (11) to a minimum torque of 4 Nm.

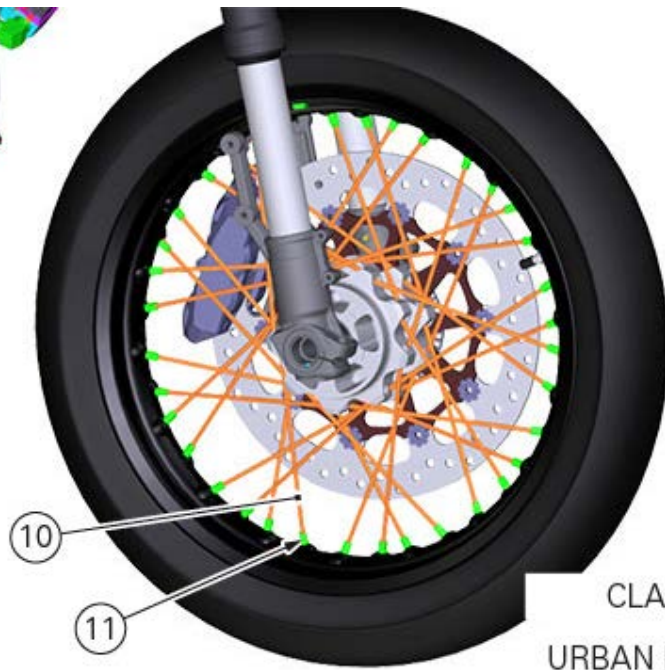

CLASSIC
URBAN ENDURO

Refitting the front wheel

When all the necessary inspections have been completed, refit the front wheel as follows.

Lubricate the wheel shaft (6).

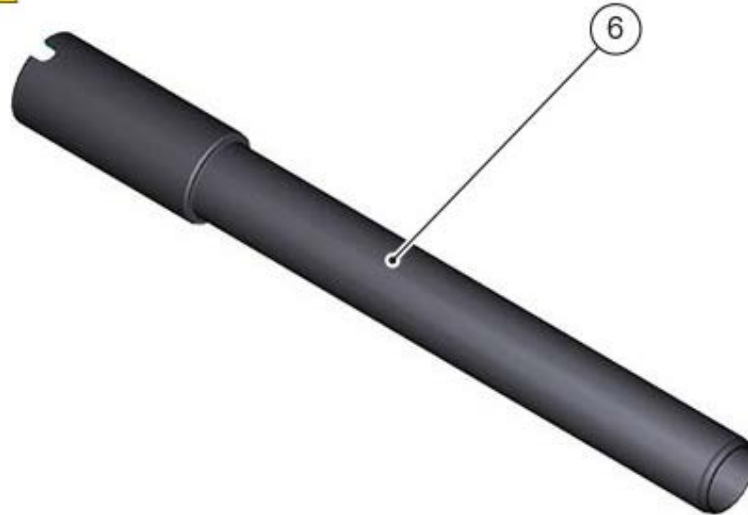

Insert front wheel between the fork legs, fitting spacer (7) between wheel hub and fork bottom end.





CLASSIC
URBAN ENDURO

Insert shaft (6).

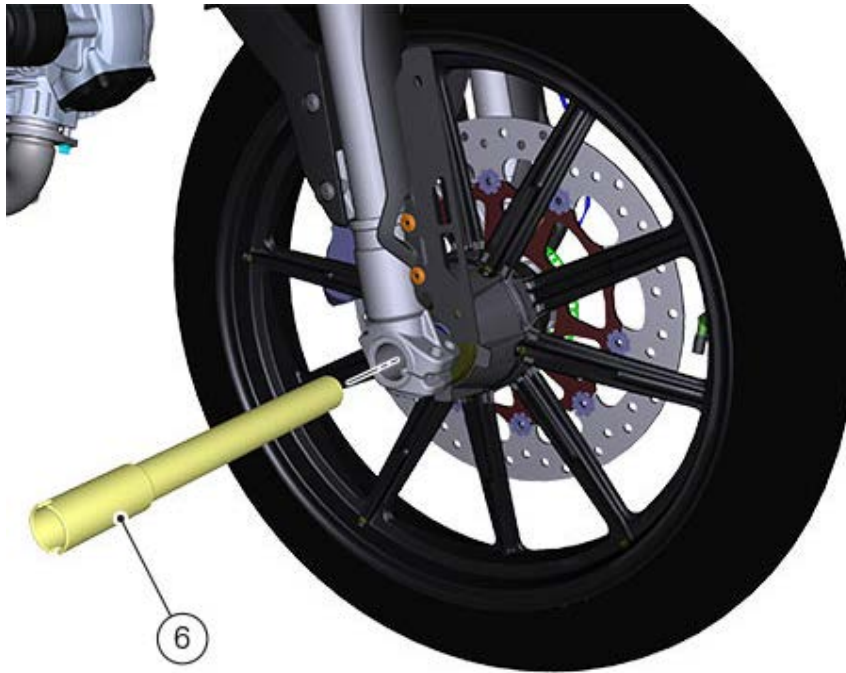

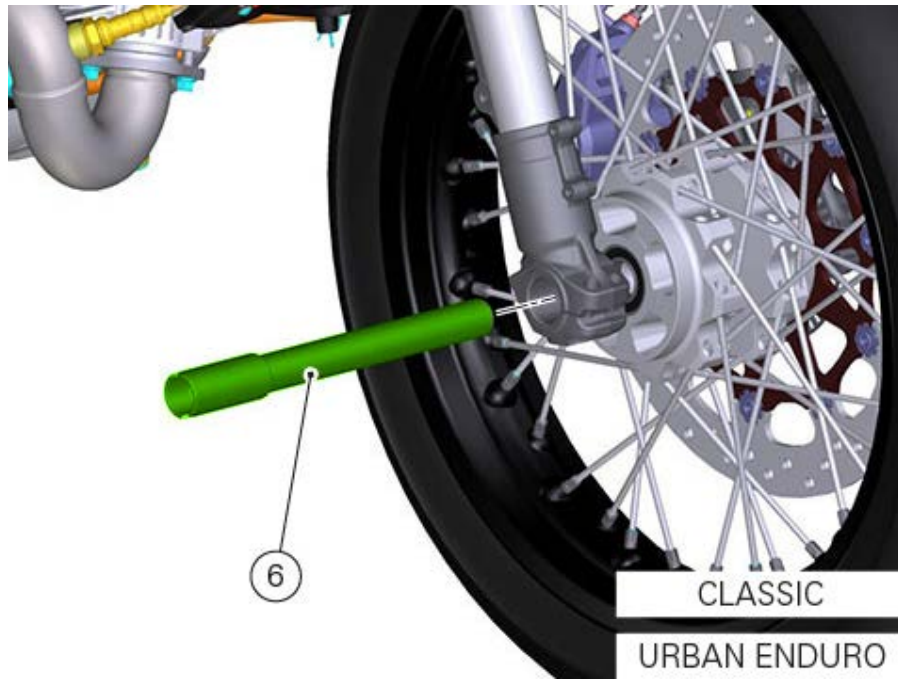

Fit nut (3) without tightening it to torque.

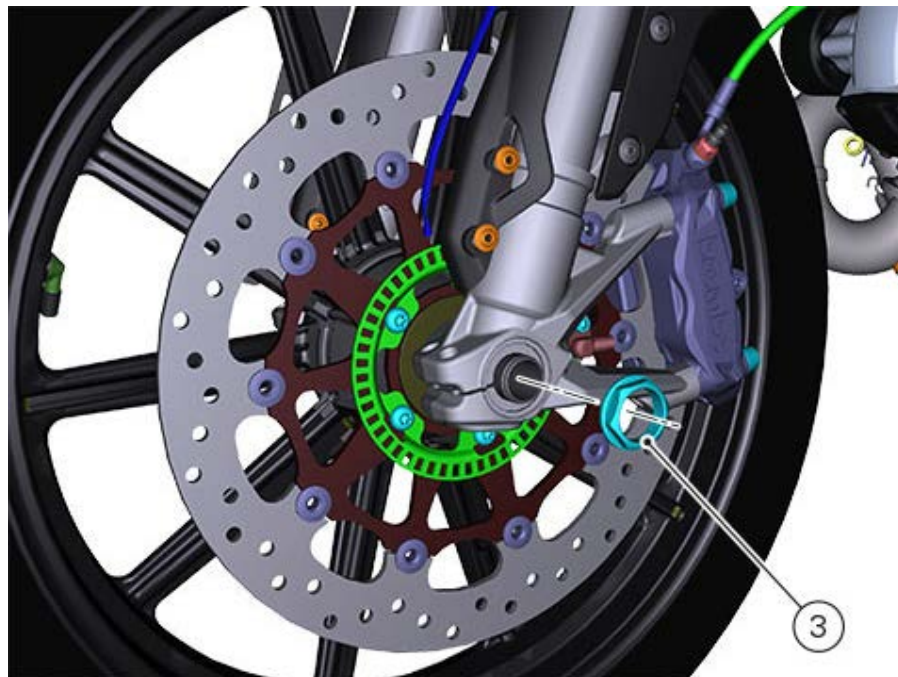

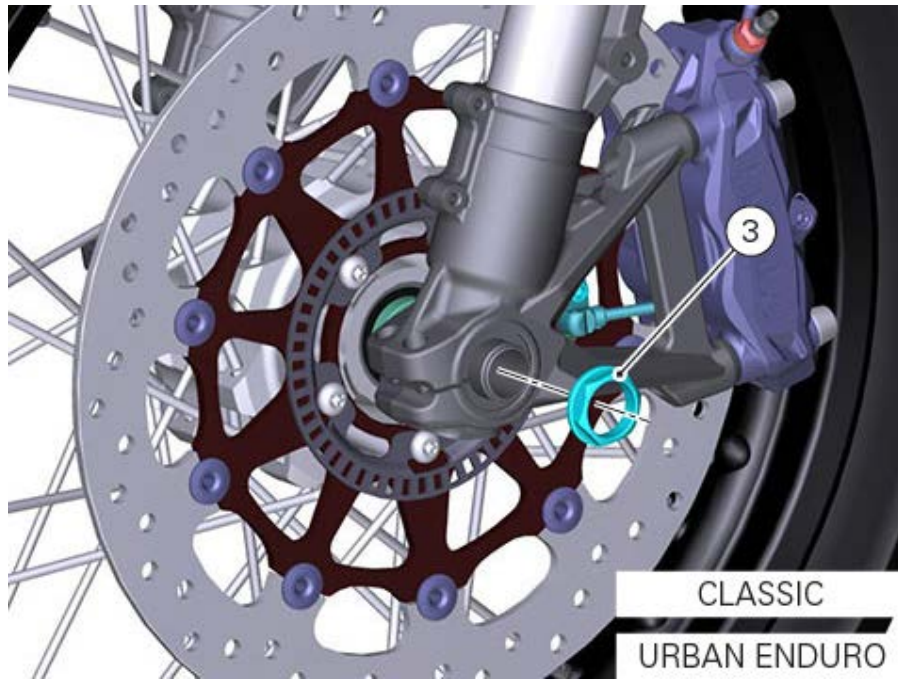

Apply the recommended grease to the thread and underside of calliper retaining screws (2).
Pre-tighten the two screws (2) to a torque of $2 \text{ Nm} \pm 10\%$.
Work several times on the brake lever to allow the calliper to settle.
Hold the brake lever pulled and simultaneously tighten the two screws (2) to a torque of $45 \text{ Nm} \pm 5\%$.



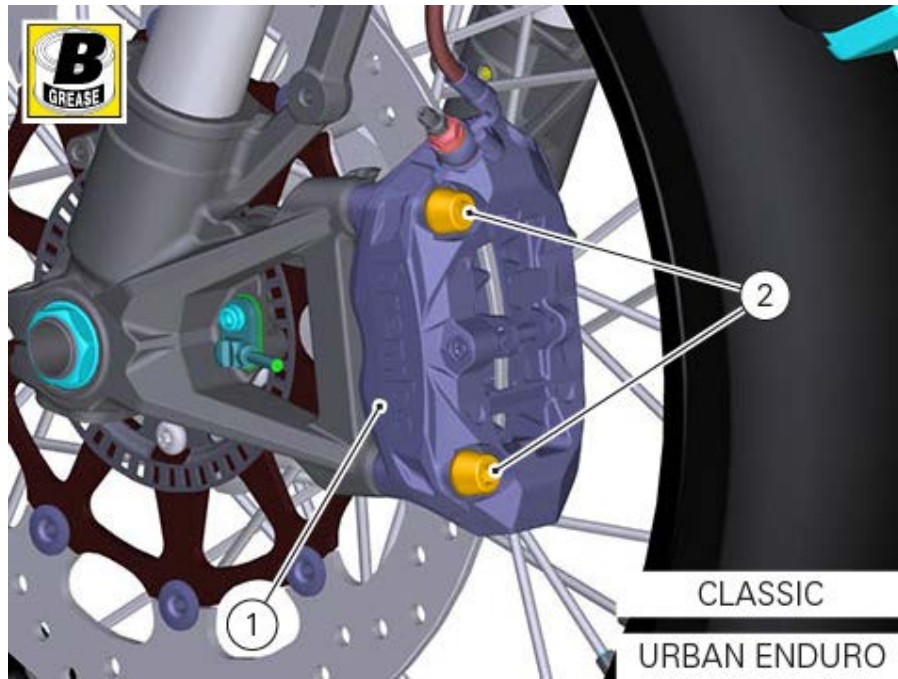

Tighten the screws (5) on the motorcycle's left side to a torque of $10 \text{ Nm} \pm 5\%$, following a 1-2-1 sequence.
Tighten nut (3) to a torque of $63 \text{ Nm} \pm 5\%$.





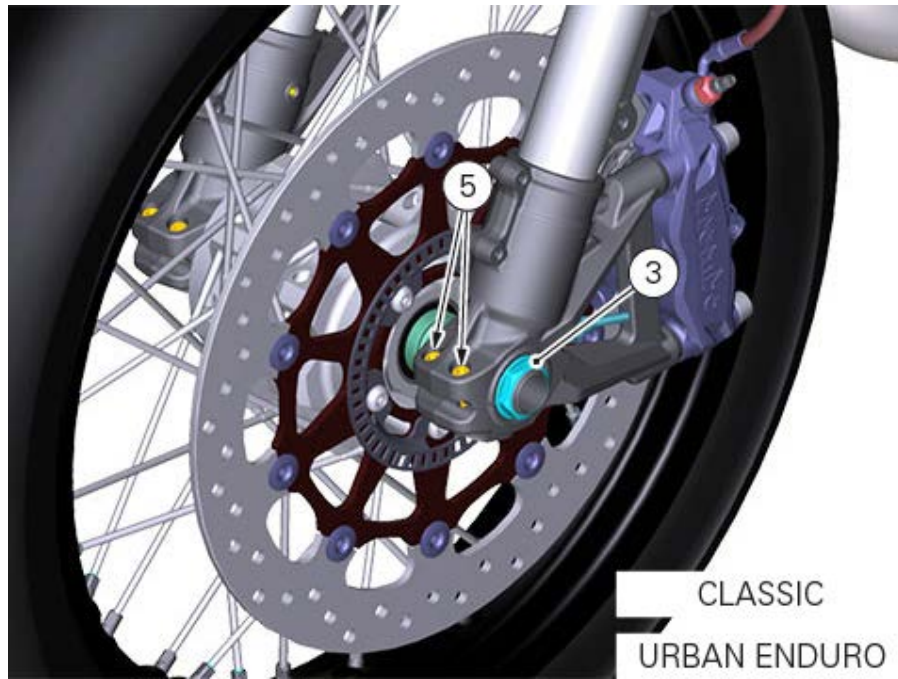

Loosen screws (5) that have been previously tightened.
Lower the bike to the ground by removing the support.
Push on the handlebar to load the suspensions and to allow the fork legs to settle on the wheel shaft.
Tighten the screws (5) to a torque of $10 \text{ Nm} \pm 5\%$, following a 1-2-1 sequence.

Overhauling the front wheel

Wheel bearings

Before checking the dimensions, check for wear on wheel hub bearings. Check for wear by hand after cleaning and degreasing the bearings in their seats.

Turn the internal ring and check that the internal balls move freely: any irregularity indicates deformations like those indicated in values "A" and "B".

An excessive wear can cause vibrations and instability of the vehicle and therefore it is necessary to replace them.

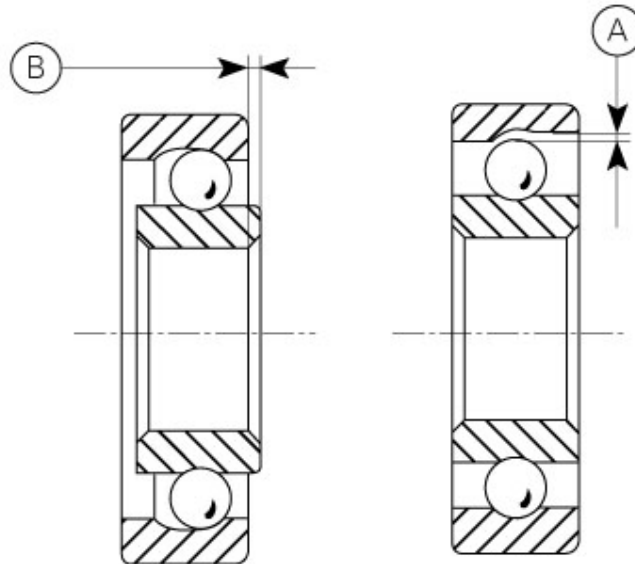

To remove the bearings and the sealing rings from the wheel hub follow the instructions below.

Position a drift (C) against the inner ring of the bearing (10).

Tap with a hammer until removing the bearing (10).

Apply the drift at different points to facilitate the removal.

Important

Once removed, the used bearings and sealing rings must not be refitted.

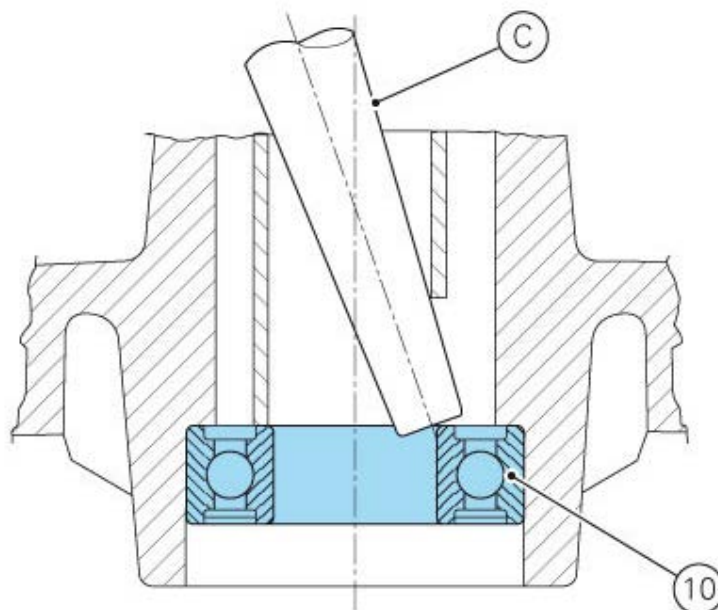

Before fitting new bearings, check that the seat is clean and free from scoring and damage. Grease the bearing seat and then push the new bearing into its seat. Using a tubular drift (D) that only bears on the outer ring of the bearing (10) to drive the latter fully into its seat.

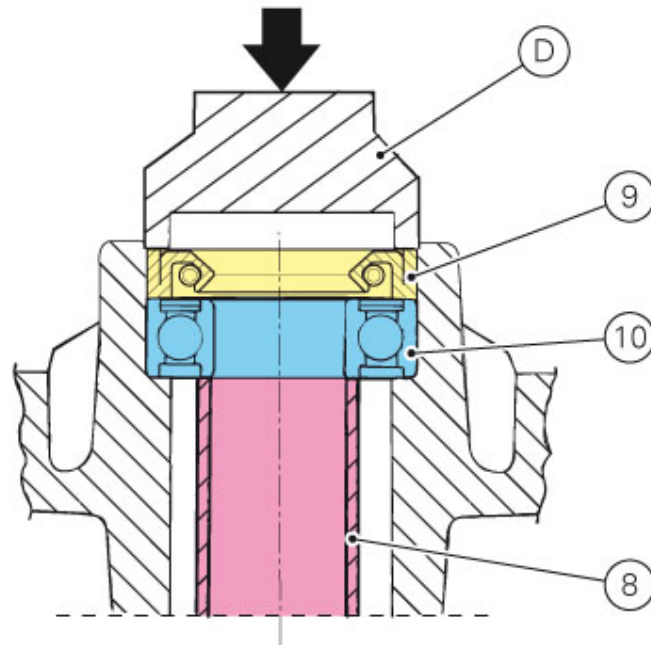

Use the same method to install the sealing rings (9). Ensure that spacer (8) is fitted between the two wheel hub bearings.

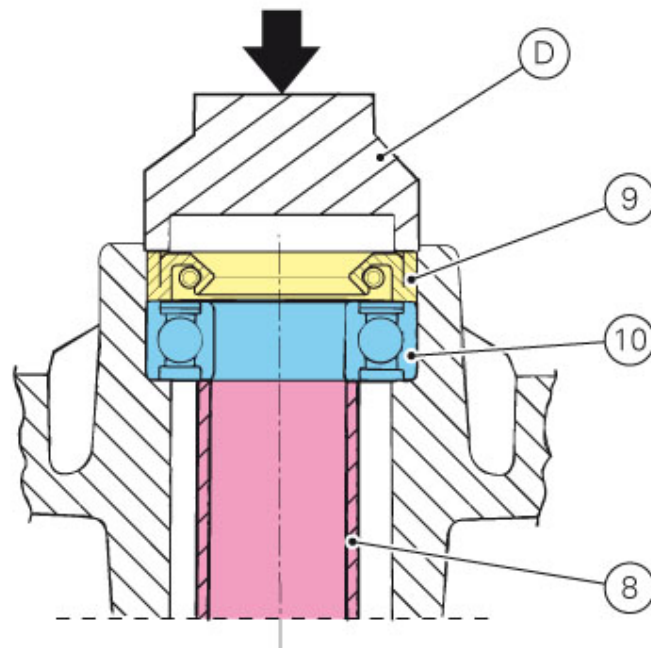

Note

Wheels must be rebalanced after repair, maintenance and overhaul operations.

Inspecting the wheel shaft

For the check values refer to paragraph ([Front Wheel](#)).

Check the wheel shaft (7) for straightness. Turn the shaft on a reference surface and measure maximum distortion using a feeler gauge.

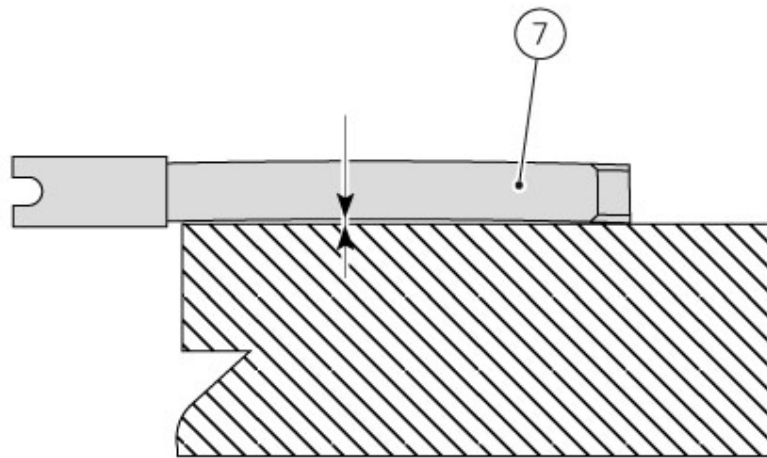

Overhauling the wheel rim

After you have checked the bearings, check the rim as follows.
Visually inspect the rim for cracks, scoring and deformation: change the rim if damaged.
Insert the shaft in the wheel and position it on two fixed reference blocks.
Using a dial gauge, measure rim runout and out-of-round with respect to the shaft axis.

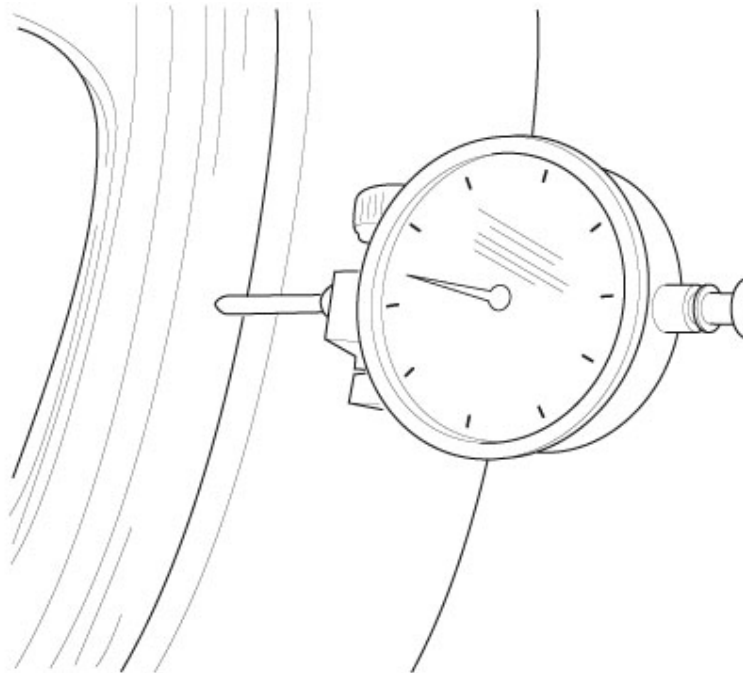

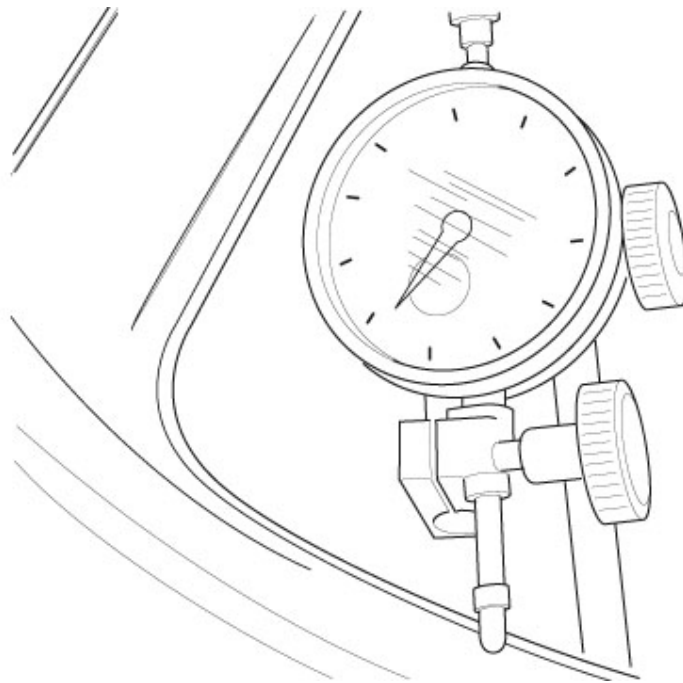

If the values measured are not within the tolerance limits, replace the wheel.

Removing the front wheel

Support the bike so that the wheel to be removed is raised from the ground.
Remove front brake callipers (1) by loosening the two screws (2) securing the calliper to the fork leg without disconnecting them from the hoses.

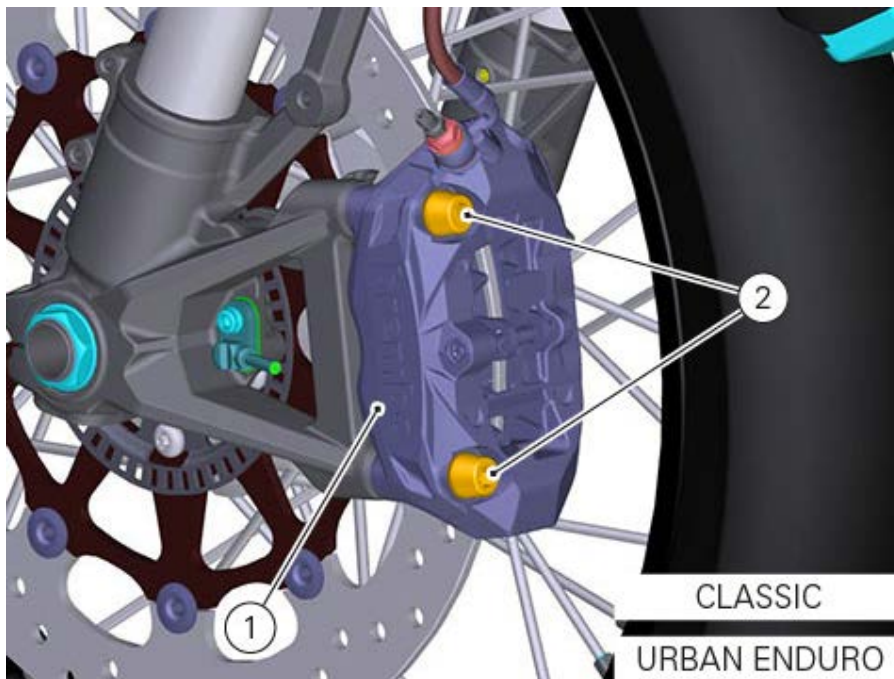

Warning

Do not operate the brake lever when the callipers are removed. This can cause the brake pad pistons to come out.

Loosen and remove nut (3) on wheel shaft left side.
Loosen the wheel shaft screws (5) on the fork legs.





Working from the left-hand side, use a plastic mallet to drive the wheel shaft (6) out from the opposite side and remove it.

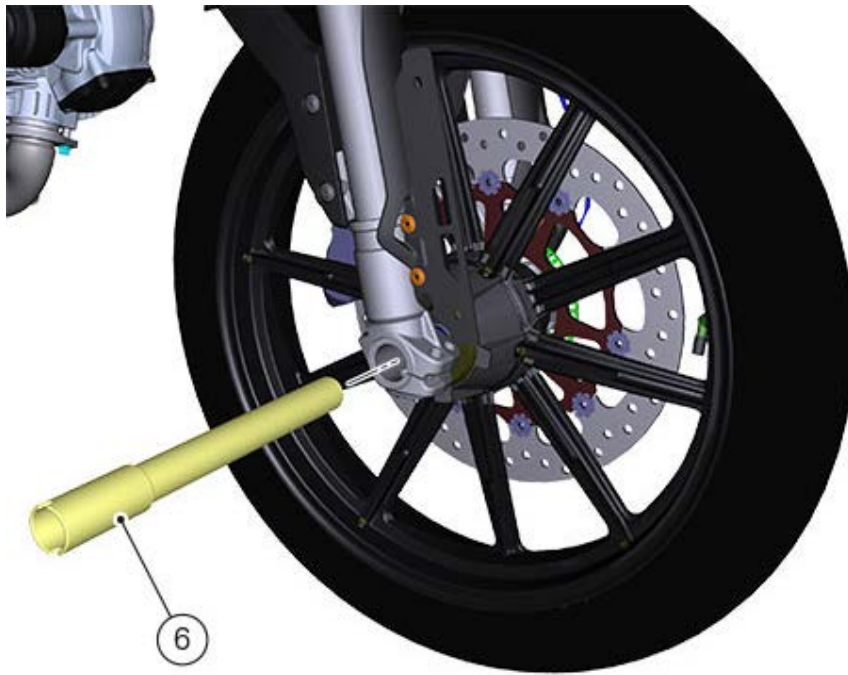
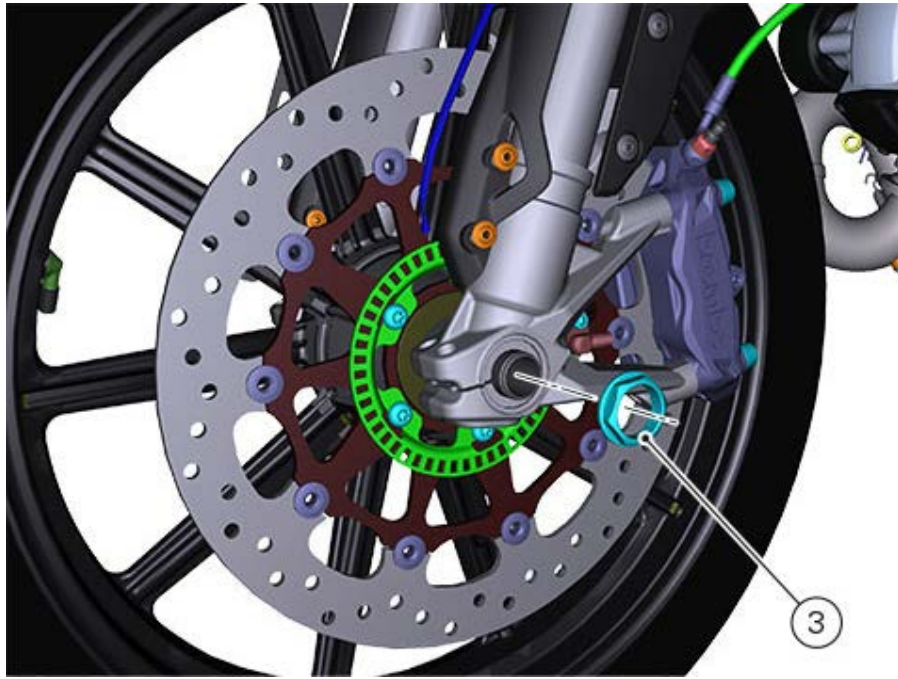

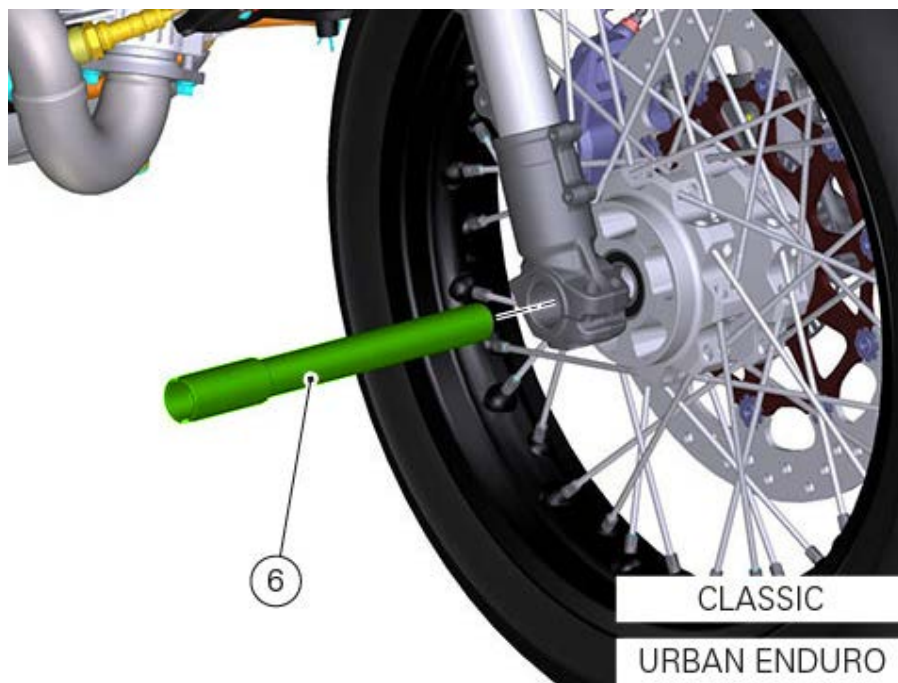
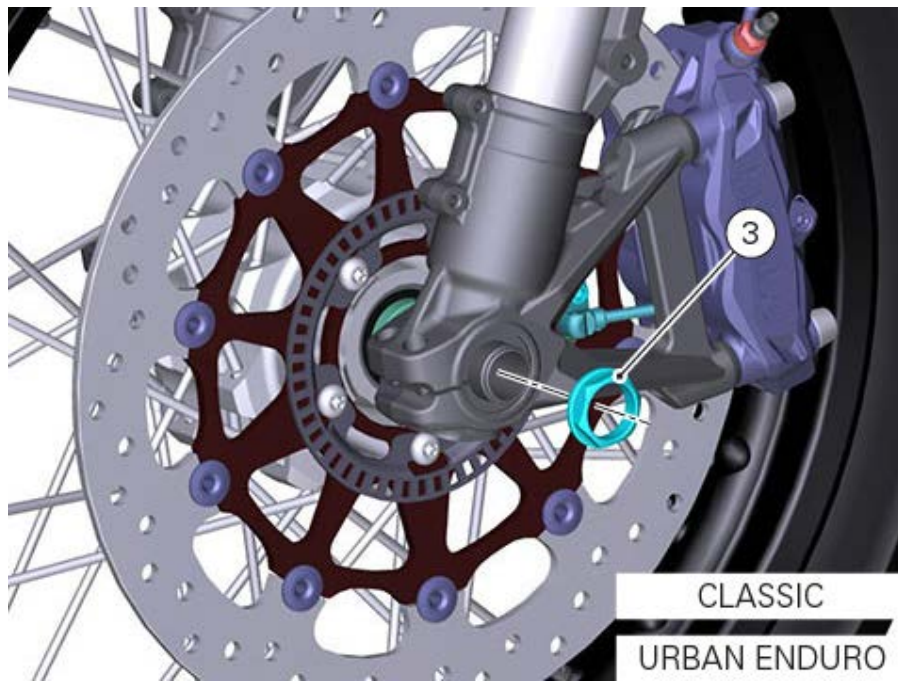

Remove the wheel and recover spacer (7).



CLASSIC
URBAN ENDURO

Overhauling the rear wheel

To overhaul the rear rim, proceed as described for the front one in "[Overhauling the front rim.](#)"

Overhauling the rear wheel

To overhaul the rear rim, proceed as described for the front one in "[Overhauling the front rim.](#)"

Refitting the rear wheel

Use specified grease to lubricate the pin ends (4) of the rear sprocket flange.



Place rear sprocket flange (5) with spacer (6) inside vibration damping pads (7).



Fit spacer (3) in the relevant seat.

Insert the retaining pin (2) after having lubricated it with specified grease.

Reposition the chain on the rear sprocket.



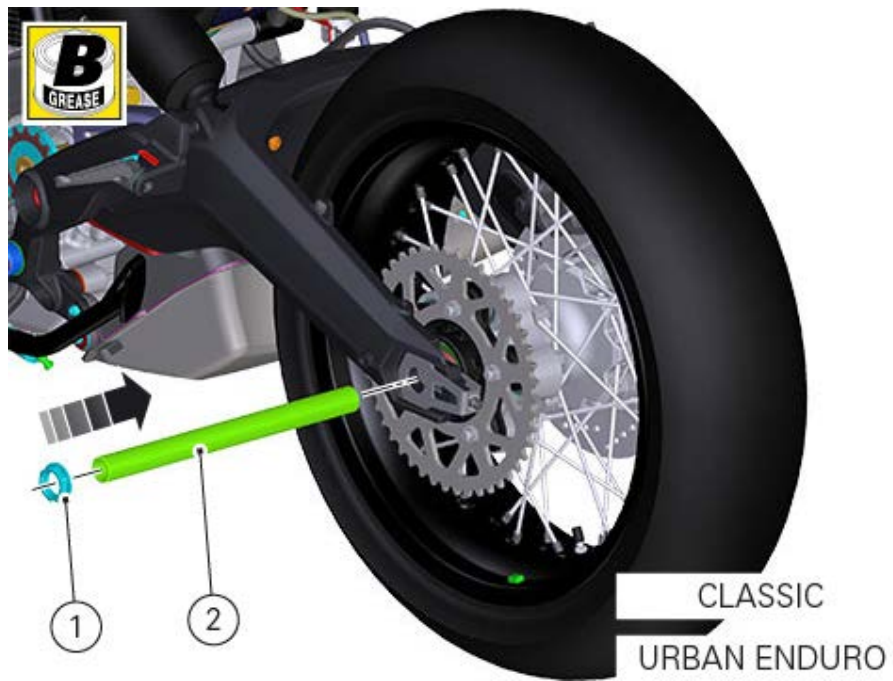

Before tightening nut (1) keep the chain tensioned ([Adjusting the chain tension](#)).

Tighten nut (1) to a torque of $145 \text{ Nm} \pm 5\%$.



Refit the number plate holder ([Refitting the number plate holder](#)).

Overhauling the rear wheel

Overhauling the wheel rim

Inspect the wheel rim as follows.

Visually inspect the rim for cracks, scoring and deformation: change the rim if damaged.

Using a dial gauge, duly supported, measure rim runout and out-of-round relative to the shaft axle.

If the values measured are not within the tolerance limits, replace the wheel.

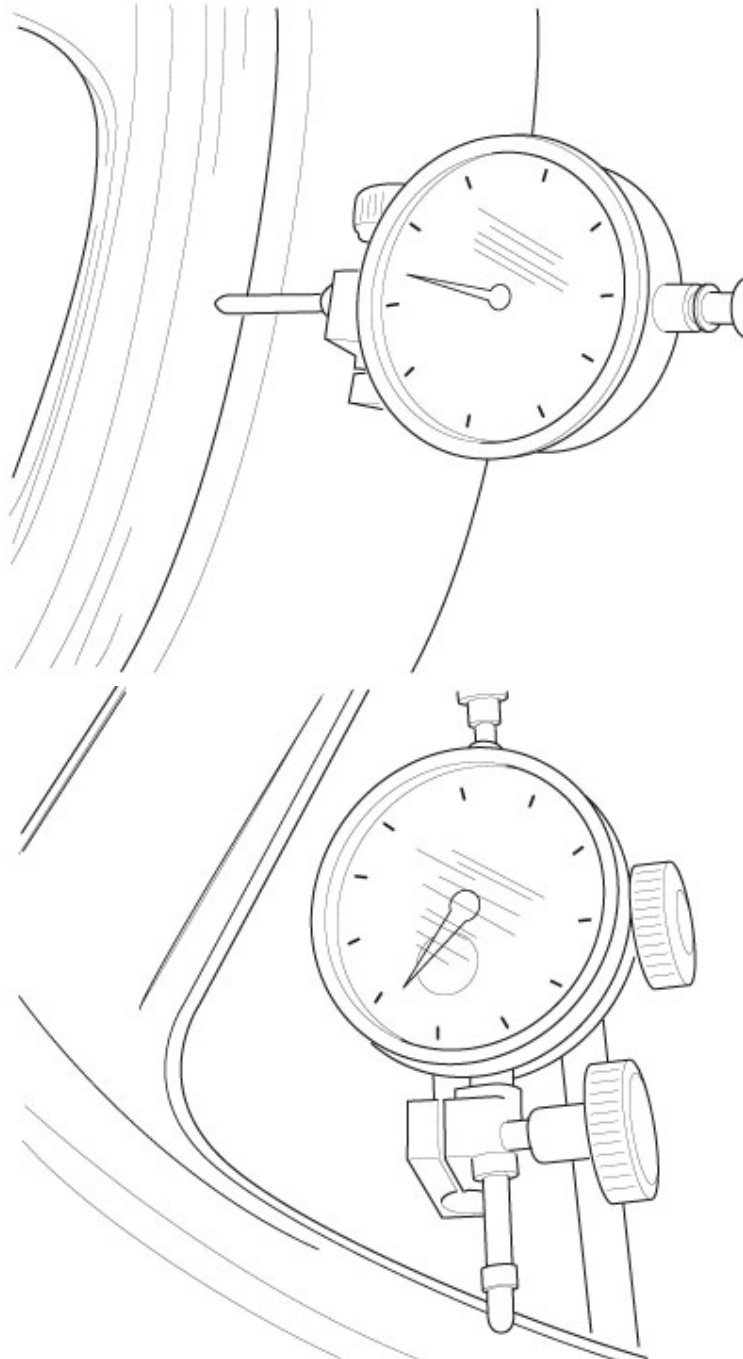

Removing the rear wheel

Remove the number plate holder ([Removing the number plate holder](#)).

Properly support the motorcycle with the service stand and engage the first gear. Loosen and remove retaining nut (1) of the rear wheel shaft.



Remove pin (2) while supporting the wheel.

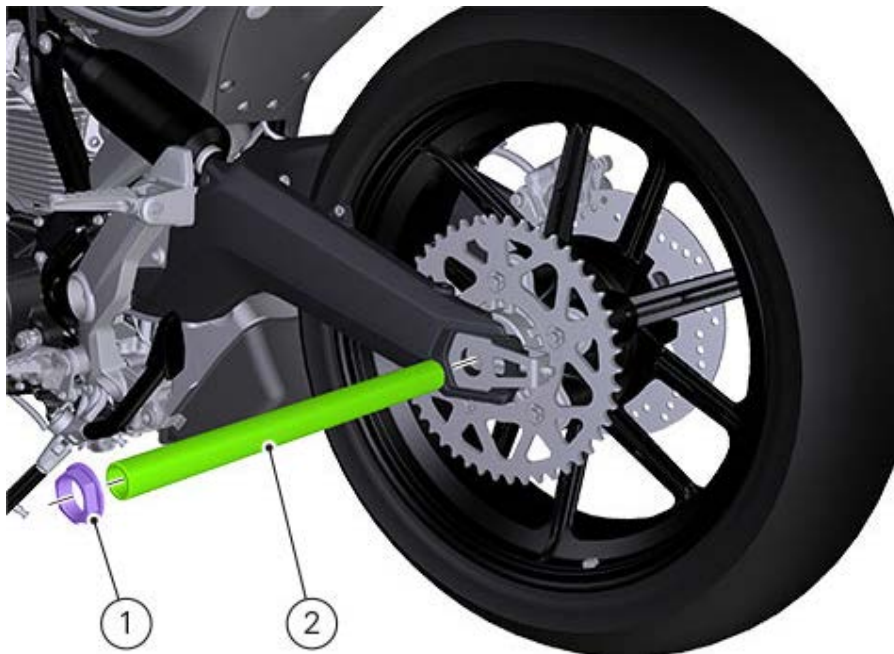

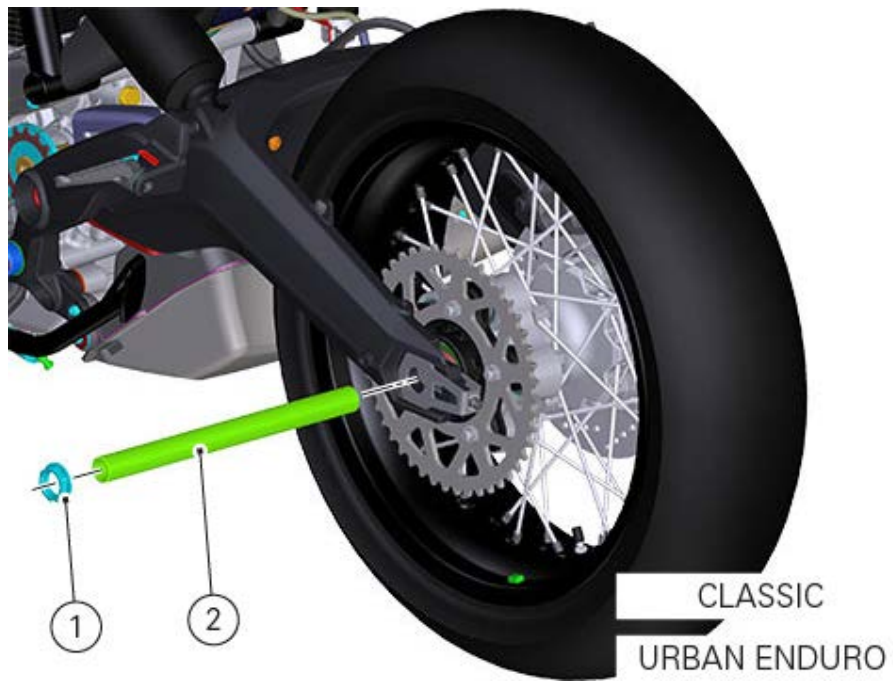

Remove the chain and the rear wheel and collect the spacer (3).
Properly support the vehicle while removing the wheel.



Refitting the front brake system

Upon the system refitting, pay attention to the orientation of the hose unions on the master cylinder and on the callipers.

Warning

If incorrectly positioned, hoses can affect brake operation and foul moving parts. Position the component as shown in the figure.

Values to be respected

X=35°

Y=60°

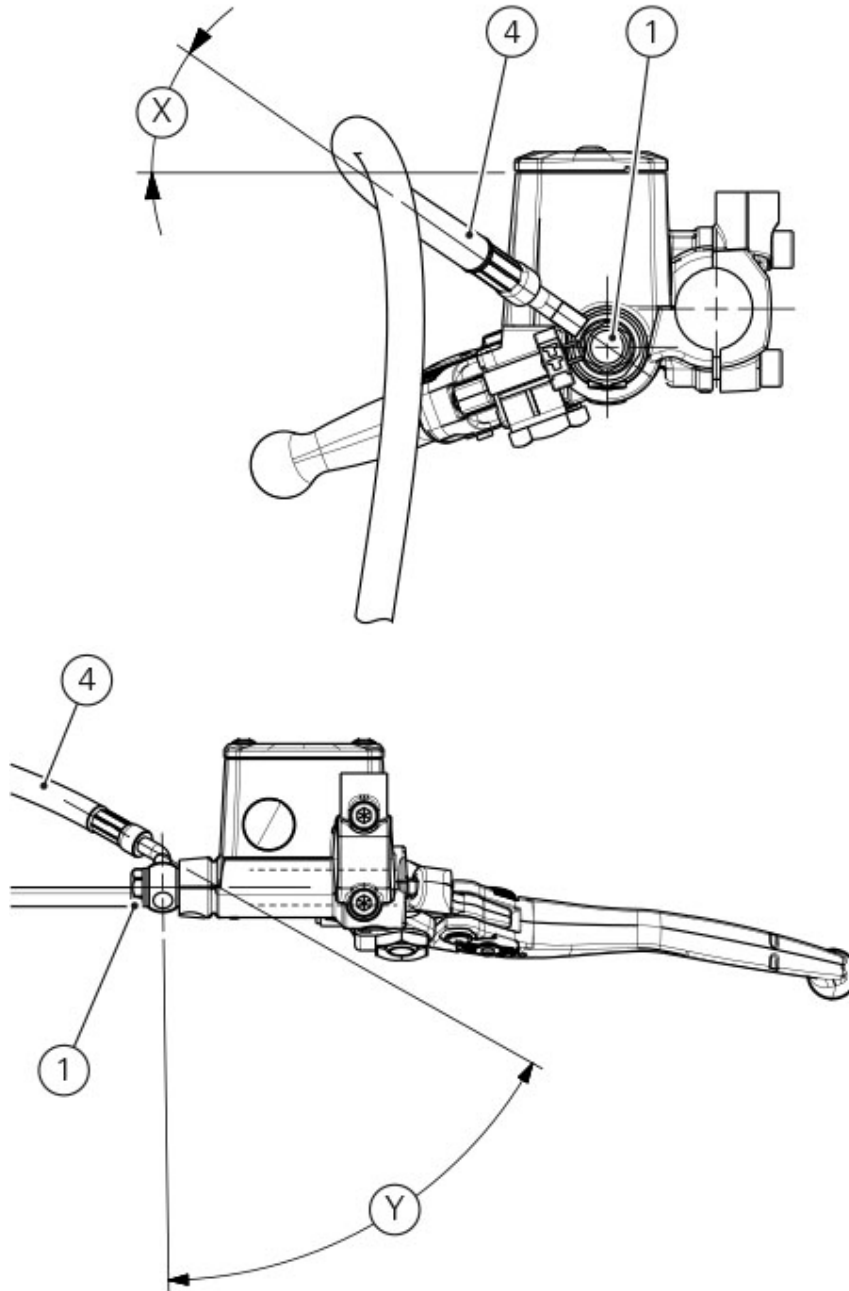

When reconnecting the brake line to the calliper or master cylinder, make sure to install the seals (2) on either side of the hose end union.

After having aimed the hose union (4), tighten screw (1) to the torque of 23 Nm \pm 10%.

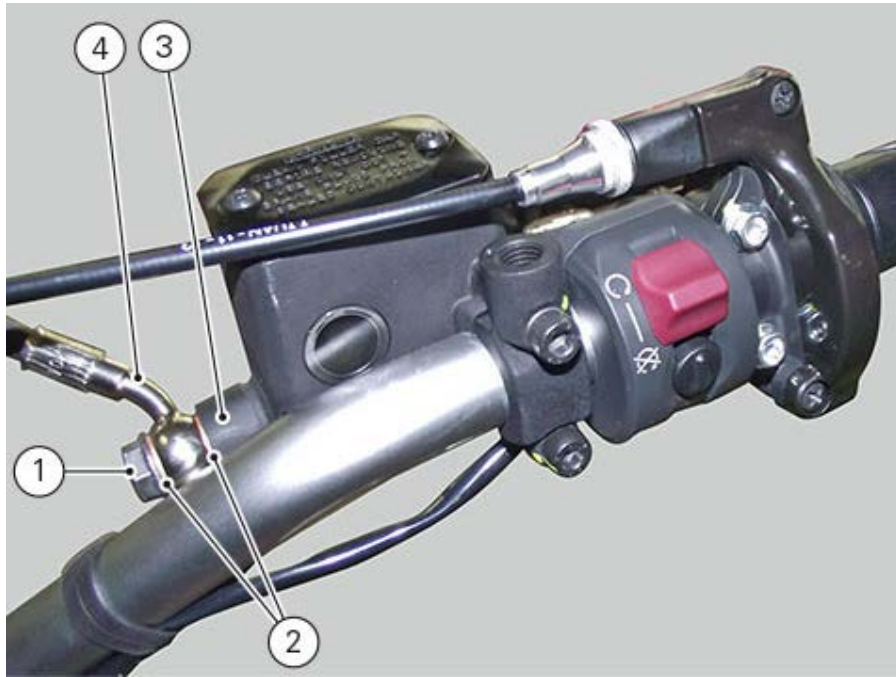

X=98°

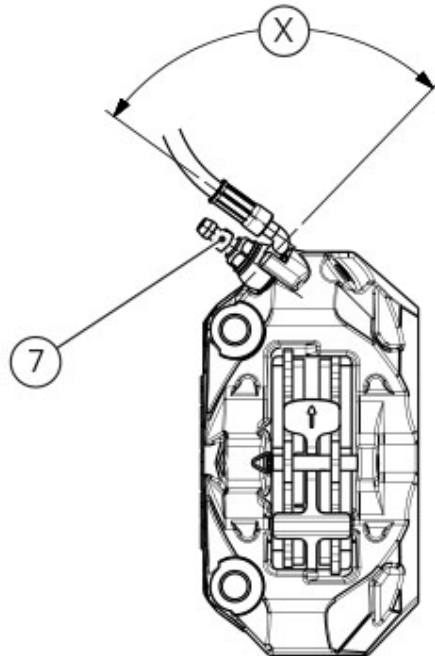

Lubricate the two screws (9) with the recommended product.
 Fasten calliper (10) by tightening the two screws (9) to a torque of 45 Nm ± 5%.
 Tighten screw (7) with seals (8) to a torque of 23 Nm ± 10%.



Secure the hose with the relevant guide (6).
Tighten the two screws (5).

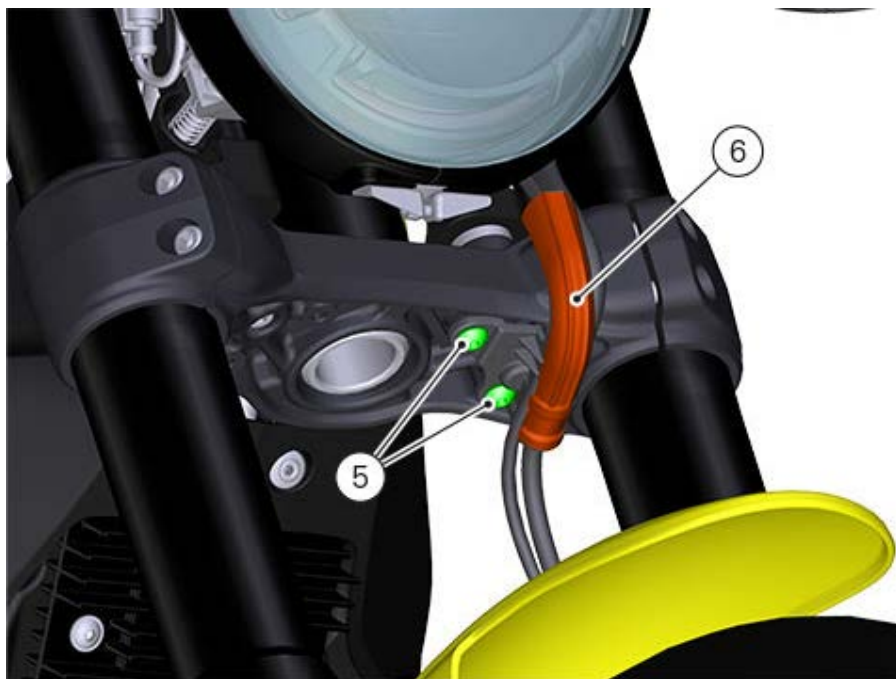

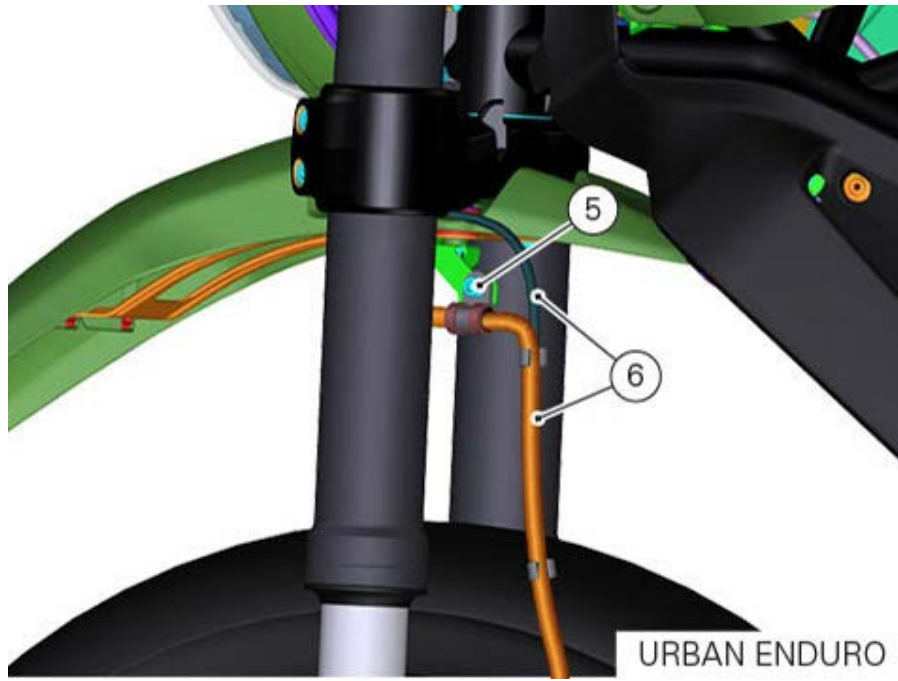

Overhauling the front brake components

Important

The brake callipers manufacturer advises against servicing the brake callipers due to the safety critical nature of this component. Incorrect overhaul of this component could endanger rider safety.

Operations should be limited to replacement of the pads, fasteners and the bleed valve assembly.

The brake disc must be clean, without any signs of rust, oil or dirt and no deep scoring.

To check the wear of the brake discs, follow the data detailed in section "[Hydraulic brakes](#)".

Removing the brake disc

The front disc consists of an inner carrier, which is mounted to the wheel, and an outer rotor. Both parts must be replaced together as a pair.

Remove the front wheel ([Removing the front wheel](#)).

Undo the screws (1) securing the brake disc to the wheel, remove disc (2) and the phonic wheel (3).



Removing the front brake system

Drain the front braking system ([Changing the front brake system fluid](#)).

Remove the rear-view mirrors ([Removing the rear-view mirrors](#)).

Undo the special screw (1), collecting the sealing washers (2) to release the front brake master cylinder unit (3) from hose (4).

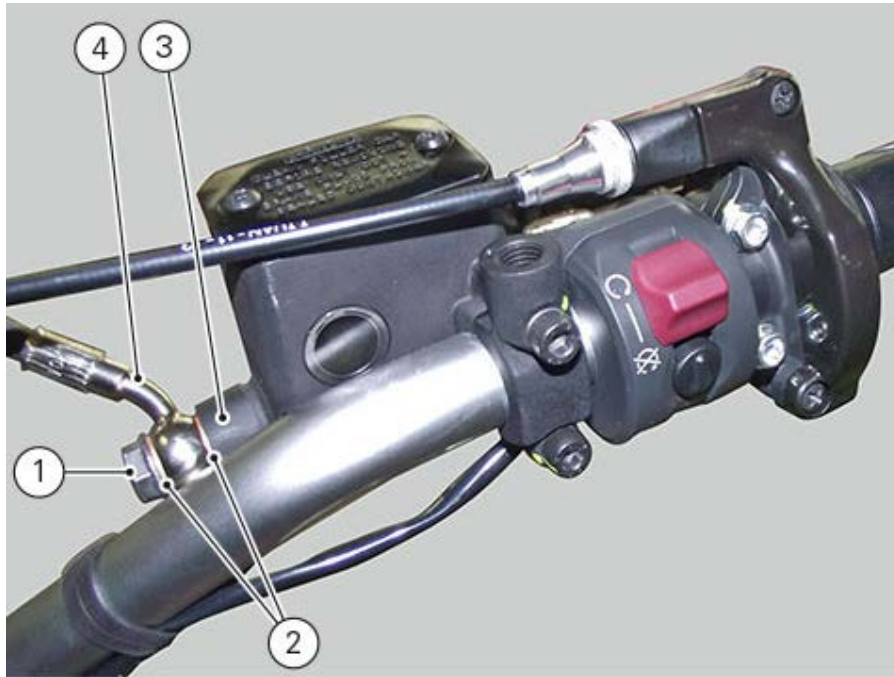

Loosen screws (5) and remove hose guide (6).

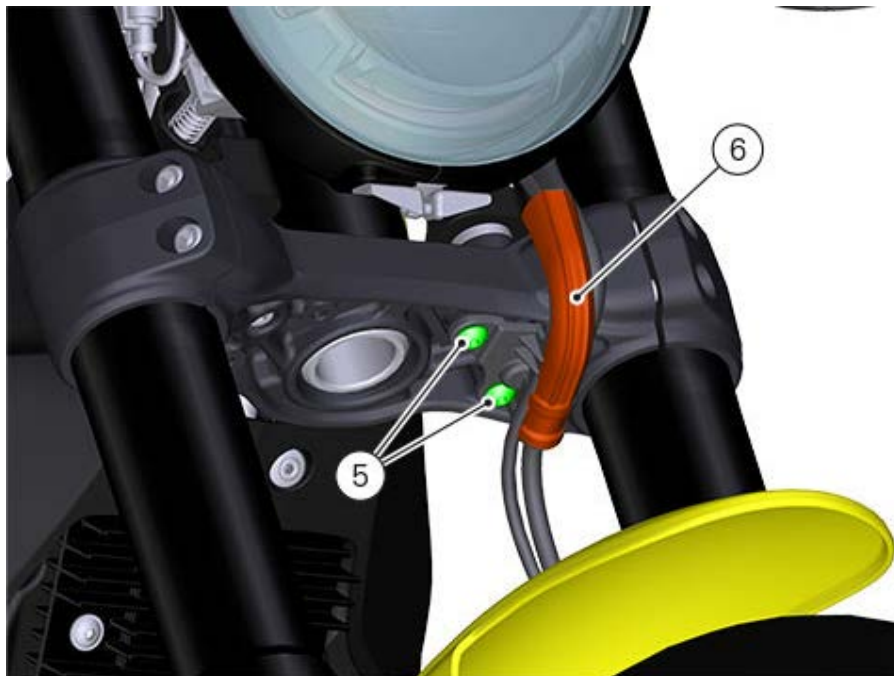

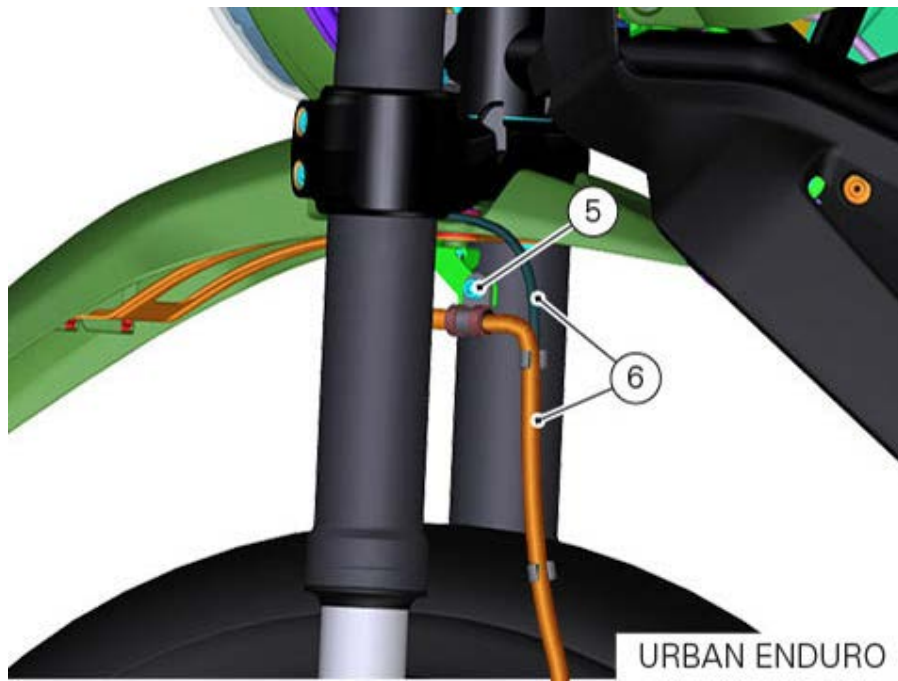

Undo special screw (7) and collect seals (8).
Remove the brake hose.
Loosen the screws (9) and remove the brake calliper (10).



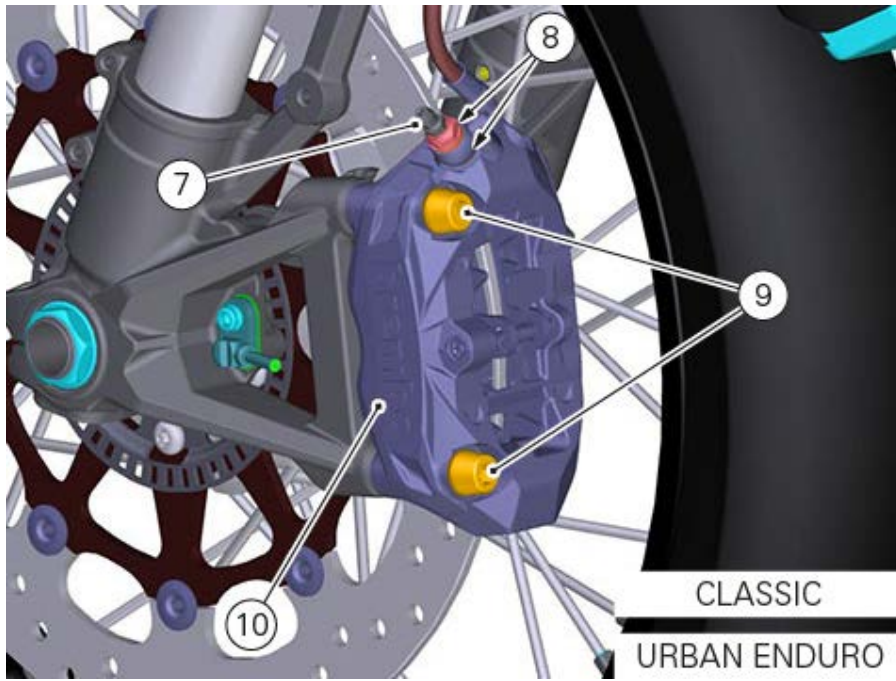

Maintenance operations



Warning

Brake fluid is corrosive and will damage paint. Avoid contact with eyes and skin. In case of accidental contact, wash thoroughly with water.

For all maintenance operations (wear check and replacement of brake pads and brake fluids, etc.) see chapter, "Maintenance operations".

Refitting the front brake master cylinder

Insert the front brake master cylinder unit (3) on the right side of the handlebar so as the clamp internal edge matches with the mark (A).

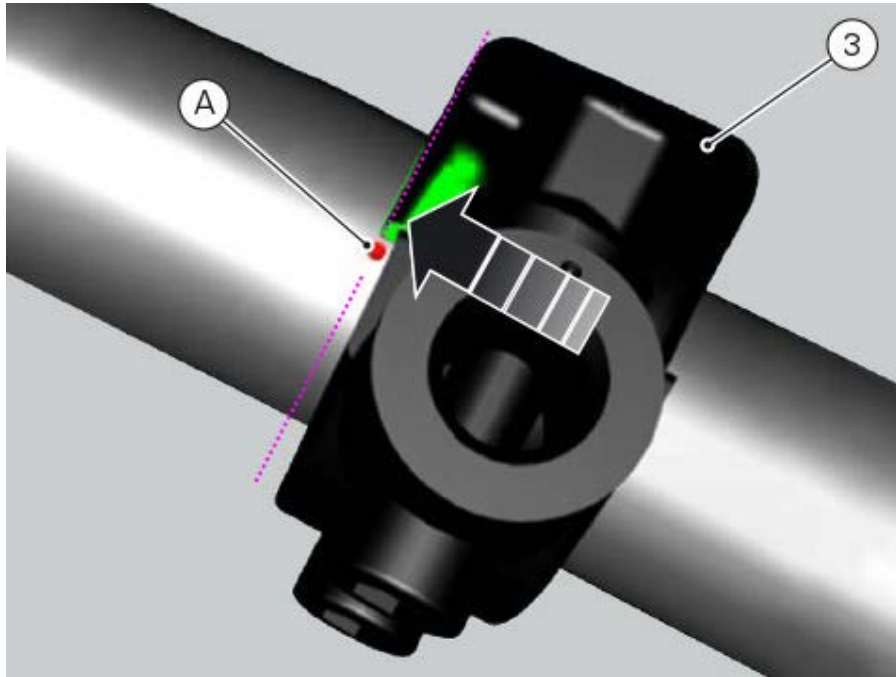

Position clamp (6) on the handlebar and start the screws (5). Tighten the fastening screws (5) to the specified torque of $10 \text{ Nm} \pm 10\%$ following the sequence 1-2-1 starting from the upper screw.

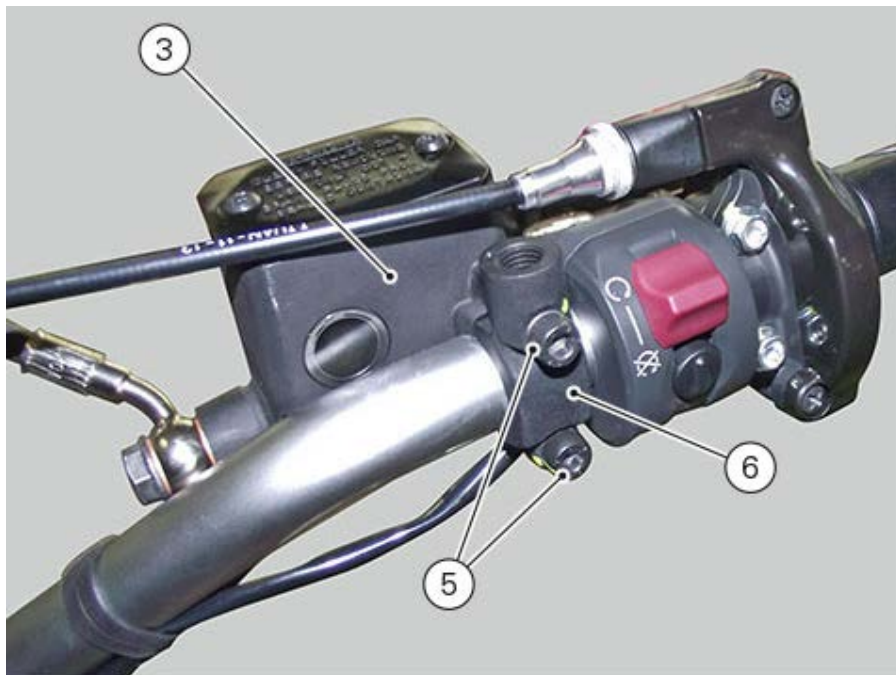

Position the hose (4) and sealing washers (2) on the master cylinder unit (3) and secure with the special screw (1), without tightening.

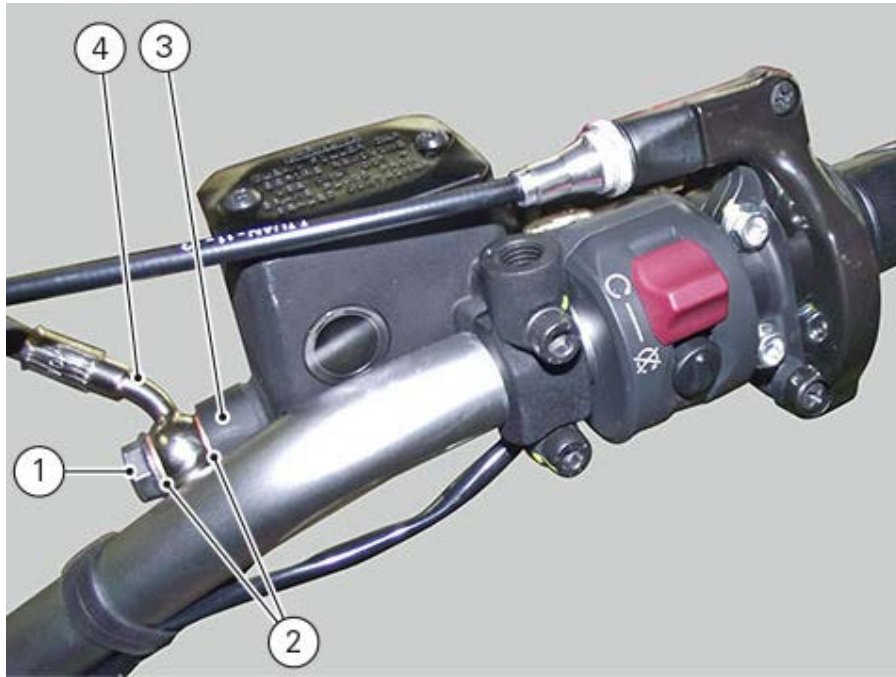

⚠ Warning

An incorrectly positioned hose can cause system faults and interfere with moving parts.

Aim hose (4) as shown in the figure by respecting values $X=35^\circ$ and $Y=60^\circ$ and then tighten the special screw (1) to a torque of $23 \text{ Nm} \pm 10\%$.

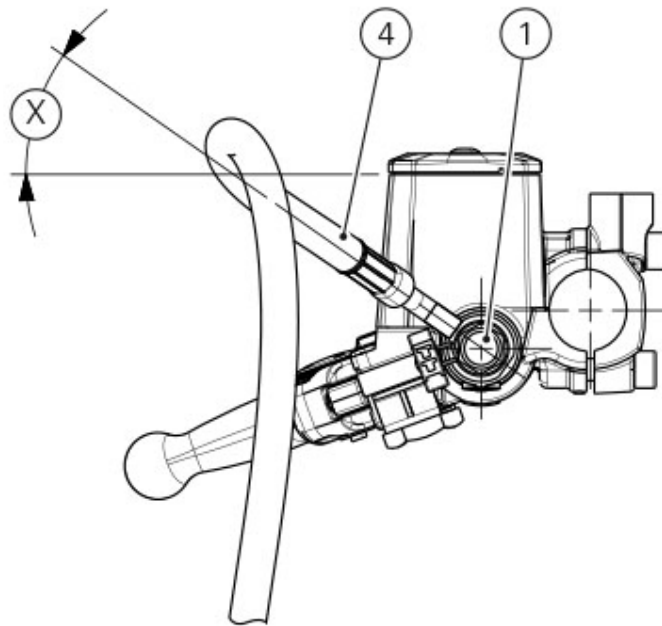

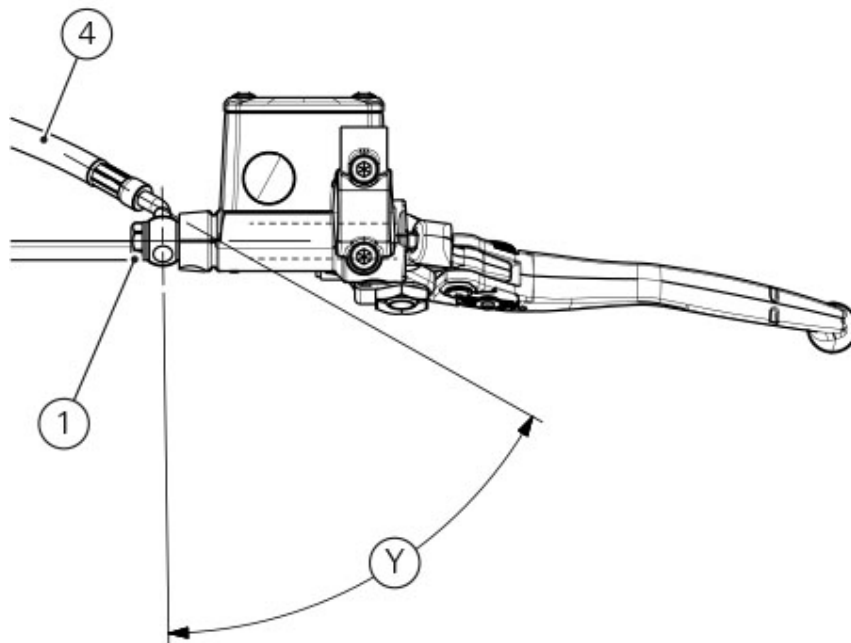

For the positioning of the hose (4) and retaining ties, see Section "[Routing wiring/hoses](#)".
Refit the rear-view mirrors ([Refitting the rear-view mirrors](#)).
Fill the front braking system ([Changing the front brake system fluid](#)).

Removing the front brake master cylinder

Warning

The brake master cylinder manufacturer advises against servicing the brake master cylinder due to the safety critical nature of this component. Incorrect overhaul can endanger rider and passenger safety. Maintenance operations on these units are limited to replacement of the following parts: control lever, fluid reservoir assembly and relative fasteners and master cylinder fasteners.

Drain the front braking system ([Changing the front brake system fluid](#)).

Remove the rear-view mirror ([Removing the rear-view mirrors](#)).

For the front ABS brake system, please also refer to Sections "[ABS system operation information](#)" and chapters "System components" and "ABS component maintenance".

Undo the special screw (1), collecting the sealing washers (2) to release the front brake master cylinder unit (3) from hose (4).

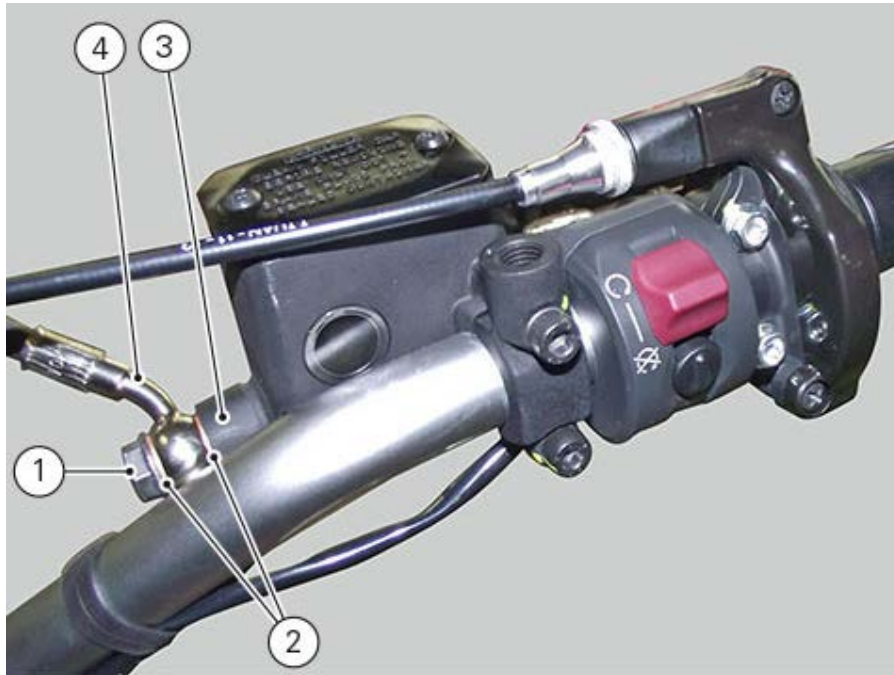

Undo the screws (5) securing the clamp (6), and then remove the front brake master cylinder assembly (3) from the handlebar.

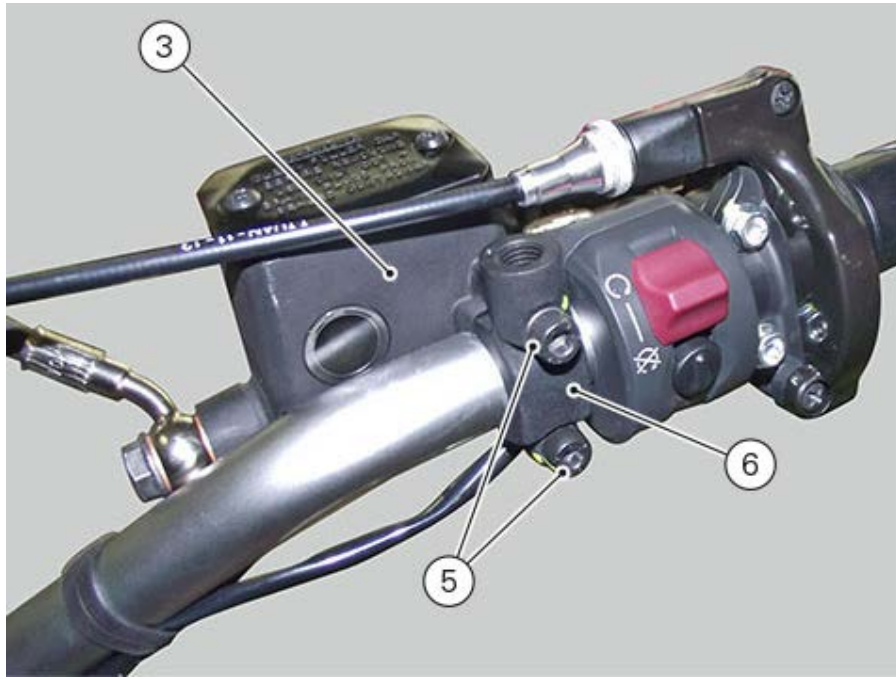

Refitting the rear brake disc

Position brake disc (2) on wheel (3) and the phonic wheel (4) on the disc.
Tighten the screws (1) with pre-applied threadlocker to a torque of $25 \text{ Nm} \pm 5\%$, in a cross pattern.



Removing the rear brake disc

Remove the rear wheel ([Removing the rear wheel](#)).

Loosen and remove screws (1) retaining the brake disc (2) to wheel (3).
Remove the phonic wheel (4).

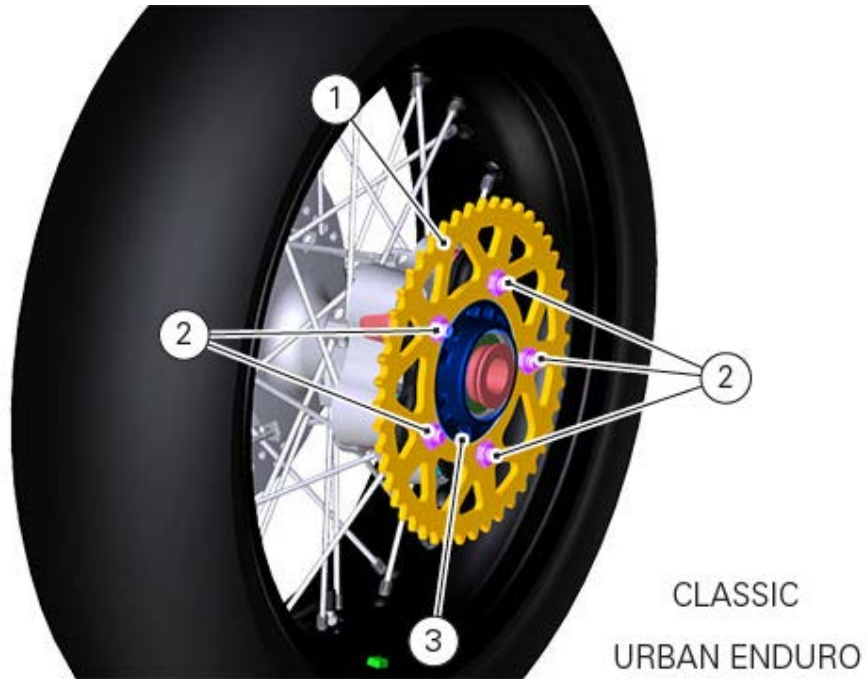

Refitting the rear brake calliper

Warning

If incorrectly positioned, hoses can affect brake operation and foul moving parts. Position the component as shown in the figure.

X=90°

Y=13°

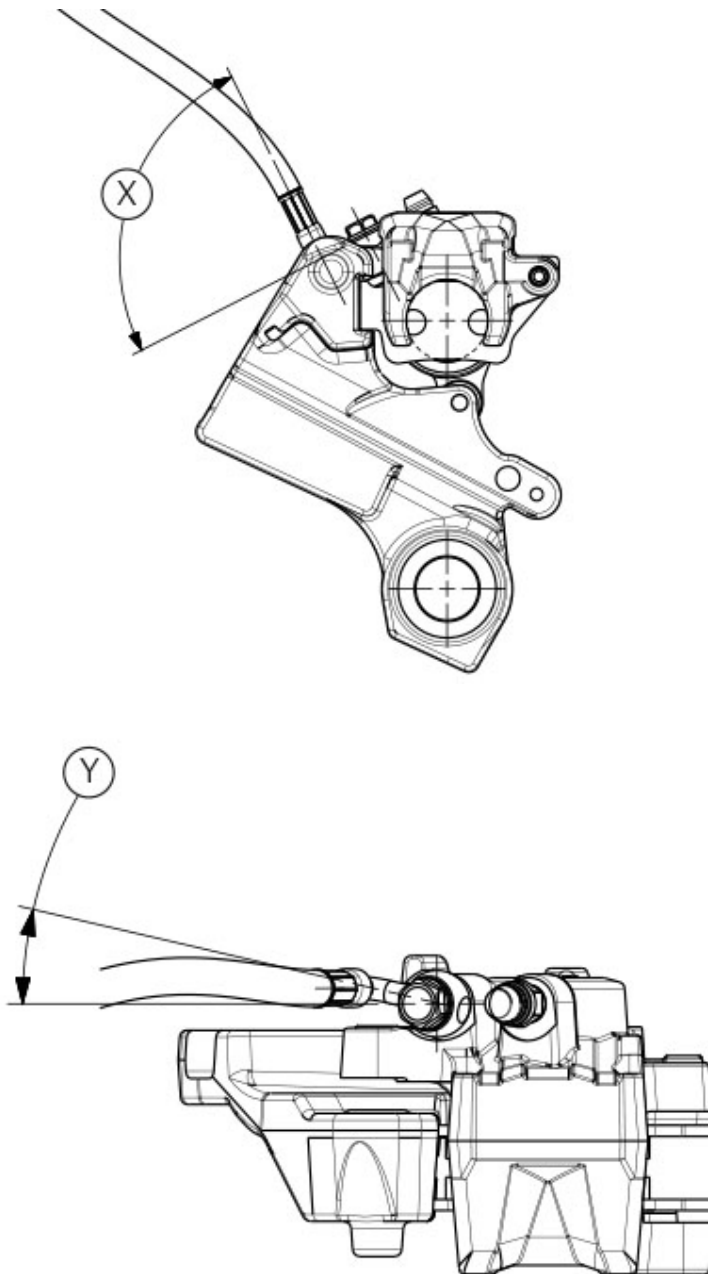

Lubricate the two pins with the recommended product.
Insert calliper (4) in calliper holder (5).

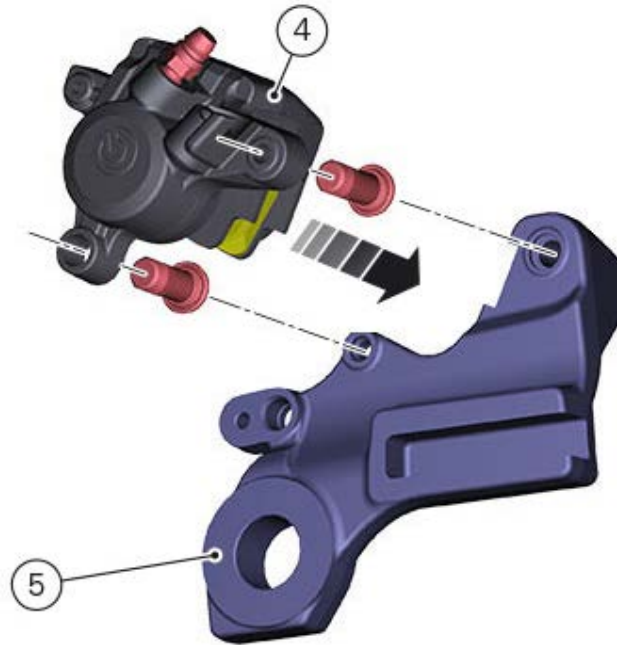

Fit the rear wheel ([Refitting the rear wheel](#)).

Tighten special screw (1) with the two seals (3) to a torque of $23 \text{ Nm} \pm 10\%$.

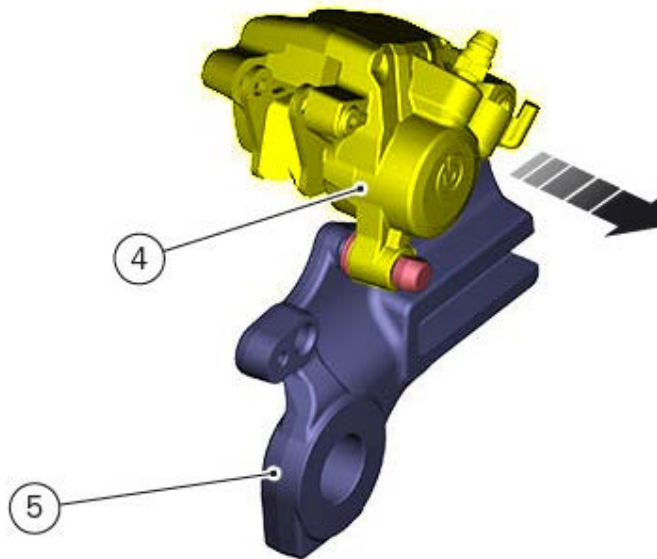

If previously removed, fit speed sensor (6) with spacer (8) and tighten screw (7) to a torque of $7 \text{ Nm} \pm 10\%$.

Check the Air-Gap ([Adjusting the phonic wheel sensor AIR-GAP](#)).

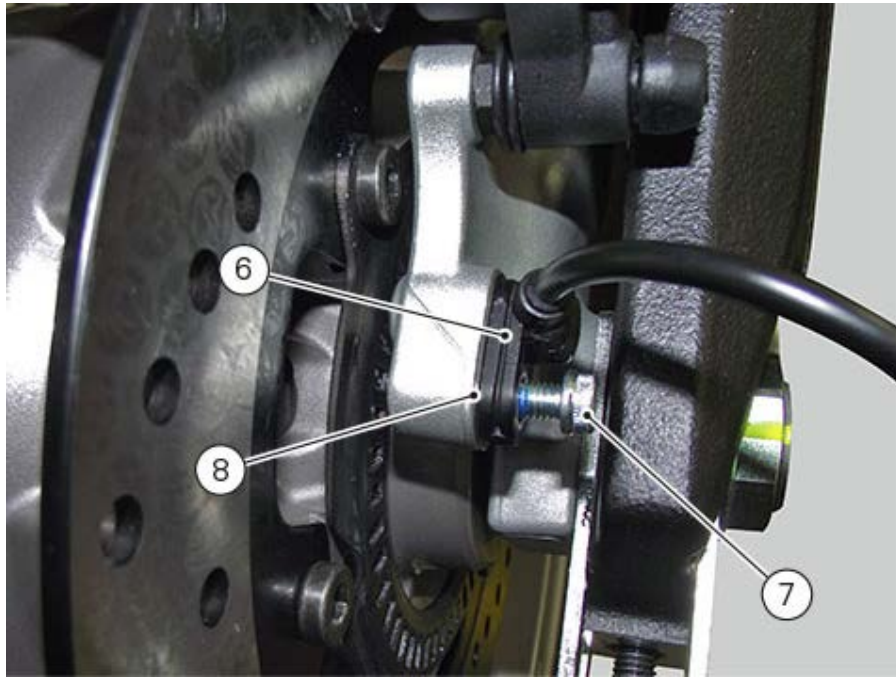

Removing the rear brake calliper

Warning

The brake master cylinder manufacturer advises against servicing the brake master cylinder due to the safety critical nature of this component. Incorrect overhaul can endanger rider and passenger safety. Maintenance operations on these units are limited to replacement of the following parts: control lever, fluid reservoir assembly and relative fasteners and master cylinder fasteners.

Drain the rear braking system ([Changing the rear brake system fluid](#)).

Loosen special screw (1) without removing it.

Remove the rear wheel ([Removing the rear wheel](#)).

Undo and remove the special screw (1) securing the hose (2) to the rear brake calliper and the corresponding seals (3).

Remove the hose (2).

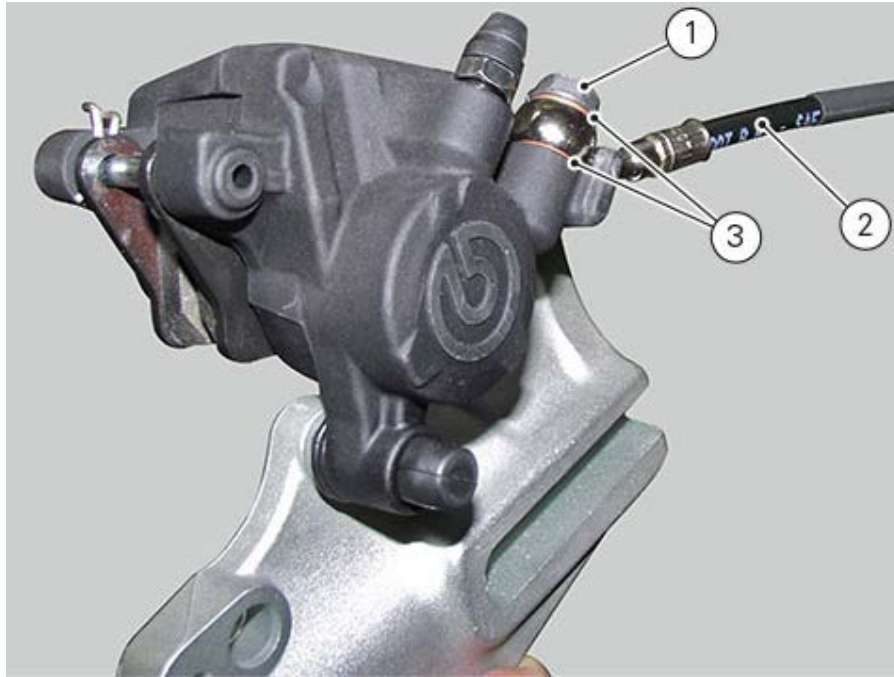

Slide out calliper (4) from calliper holder (5).

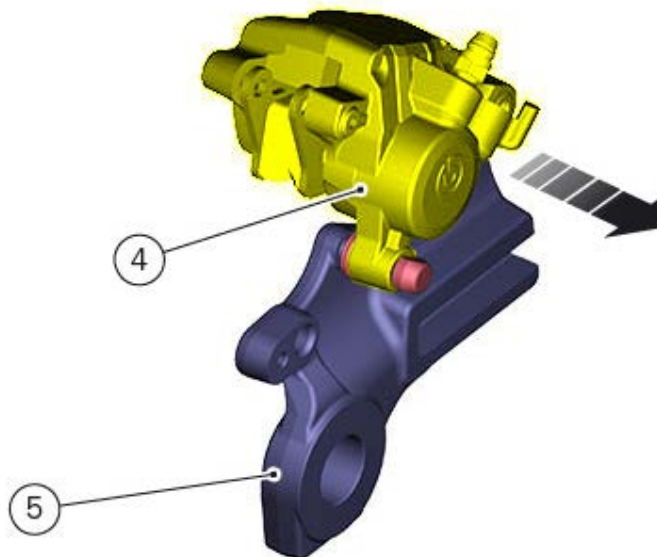

To replace the brake pads follow instructions in the paragraph "[Checking brake pad wear and replacing rear brake pads](#)".

To remove the speed sensor (6), undo the fastening screw (7) paying attention to the spacer defining the airgap (8).

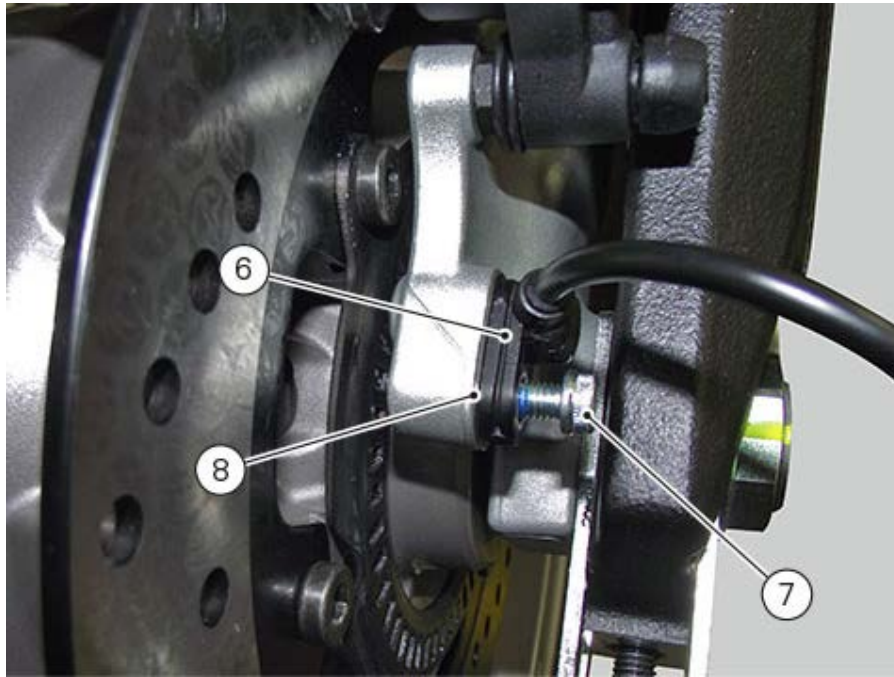

Refitting the rear brake control

If previously removed, fit the activation rod (4) by fixing it with pin (13).
Lock shaft using retainer (14).

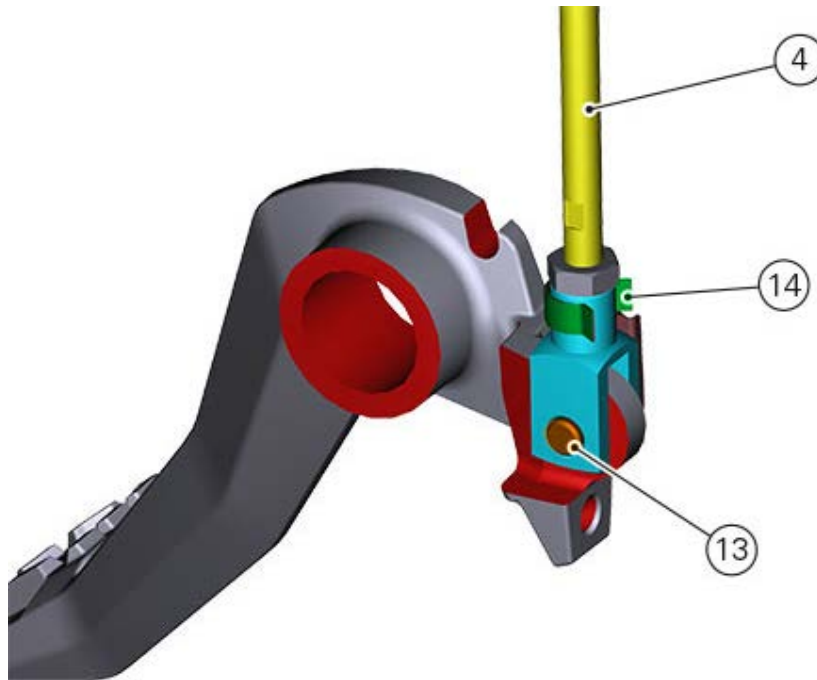

Reconnect hose (11), locating seals (12) on both sides of the hose union, and secure it with the special screw (10).

Tighten the special screw (10) to a torque of $23 \text{ Nm} \pm 10\%$.

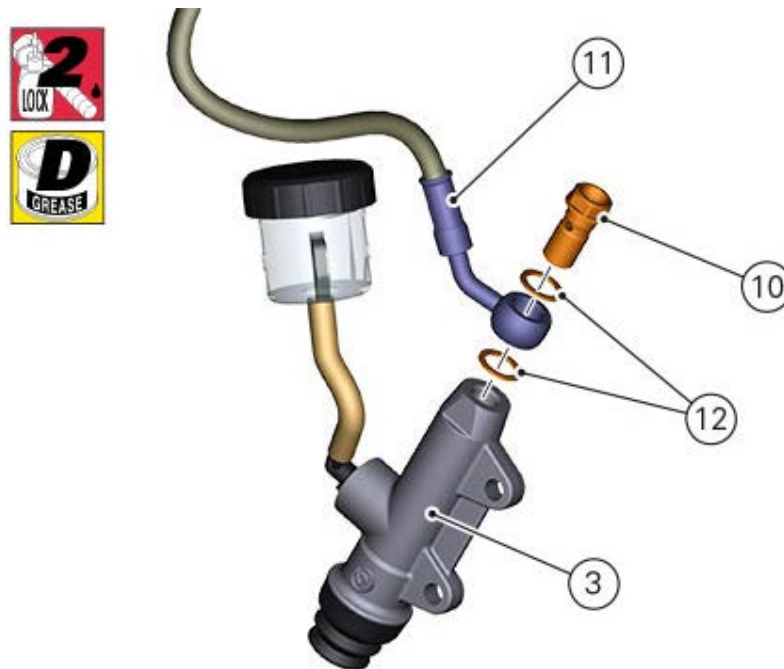

Note

Pay particular attention to the hose routing and hose coupling on the rear brake master cylinder

X=46°
Y=91°
Z=13°

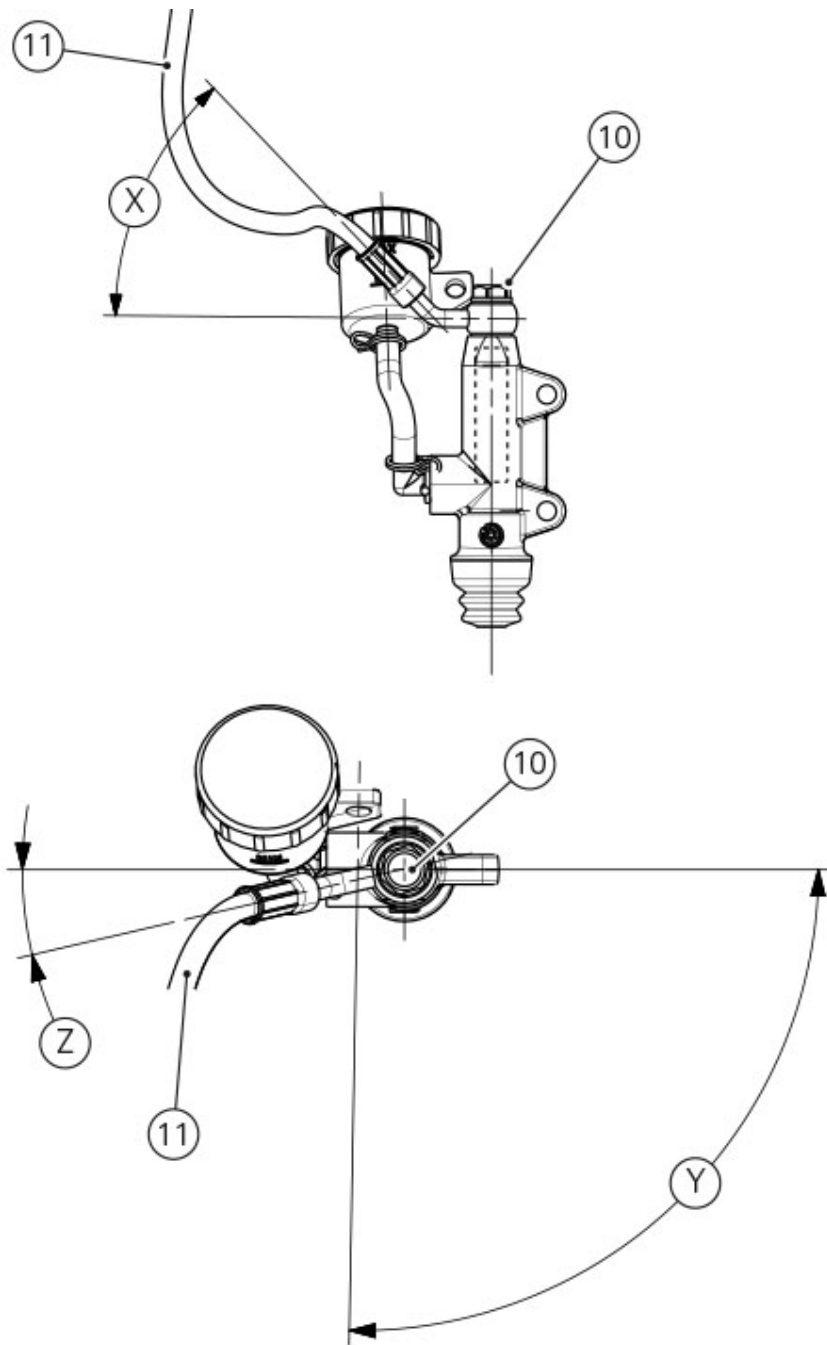

Fit washer (15) on the footpeg holder plate (8).

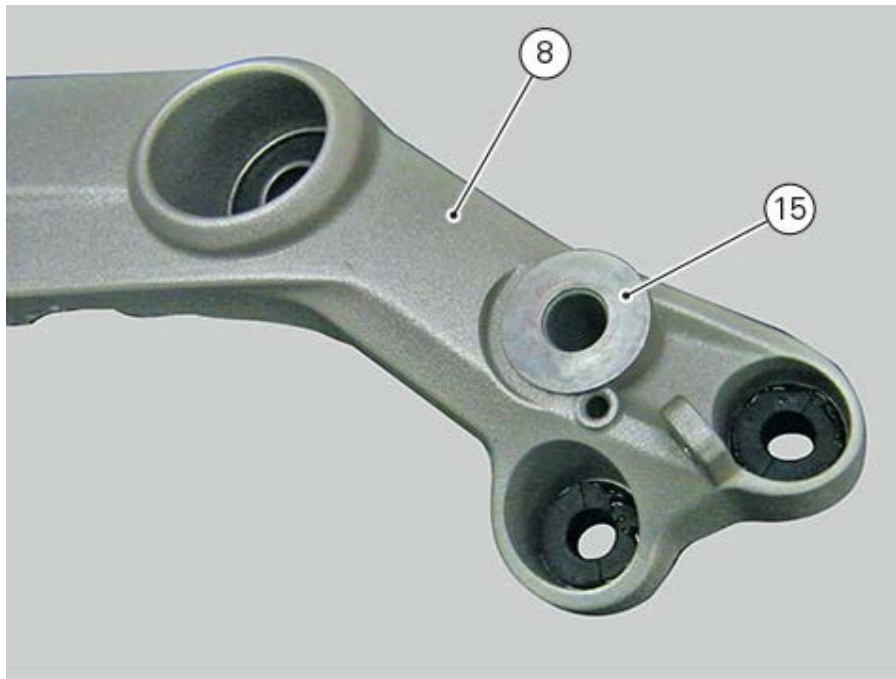

Fit spring (9) by inserting its end in the seat on the footpeg holder plate (8).



Fit footpeg (6) into lever (7).
Grease O-ring (16) with indicated product.

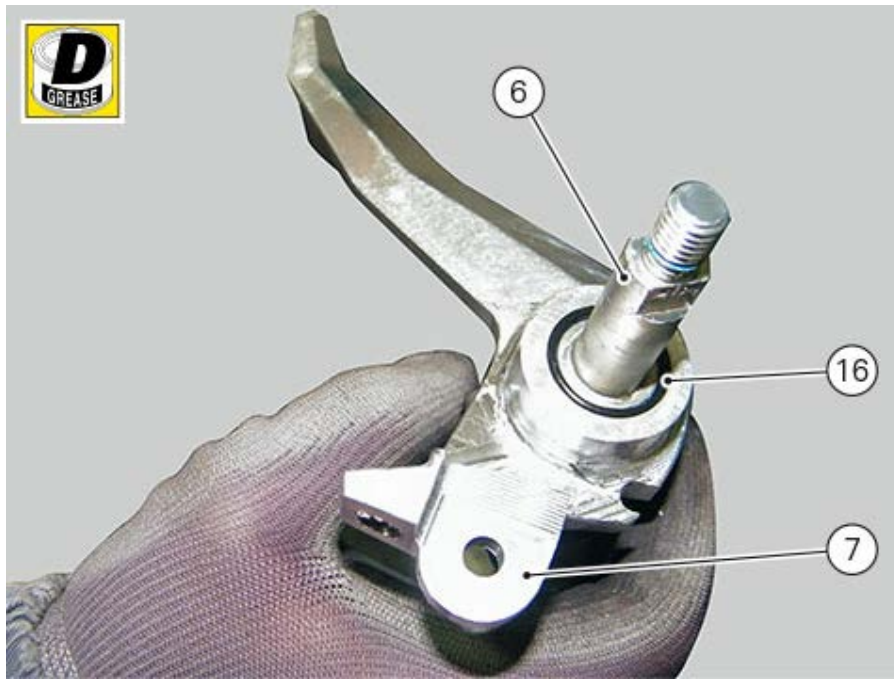

Insert the footpeg/brake lever assembly in footpeg holder plate (8).
Engage spring end (9) in the recess on the brake lever (7).

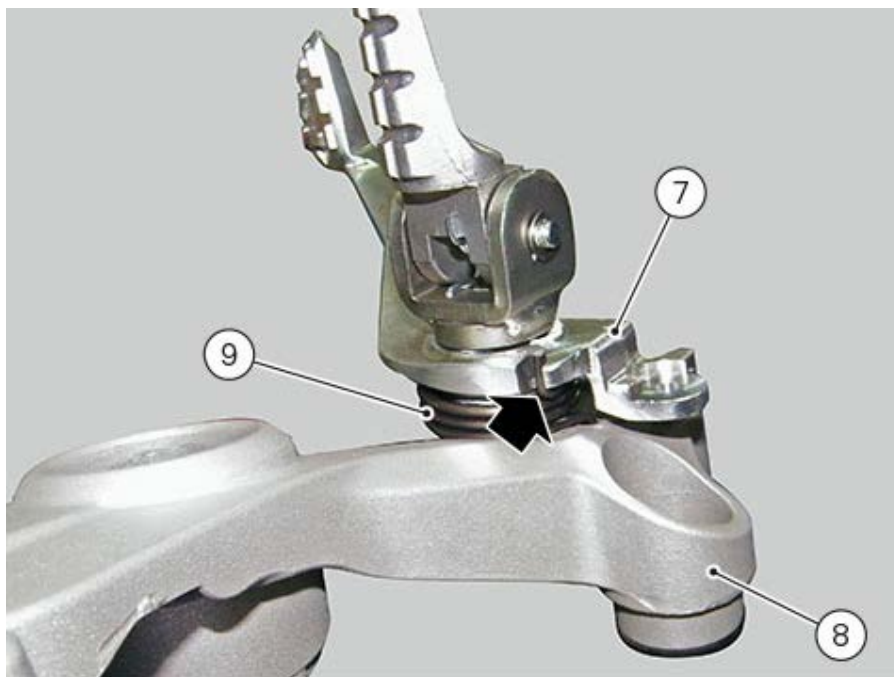

Apply the specified threadlocker and tighten nut (5) to a torque of $22 \text{ Nm} \pm 5\%$.

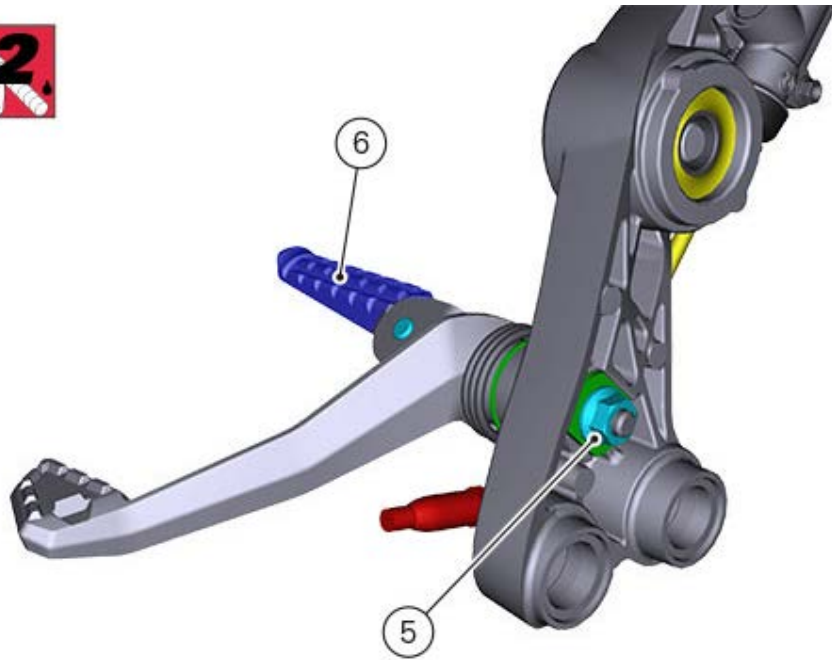

Apply the recommended threadlocker on the screws (2).
Position the rear brake master cylinder (3) on the vehicle inserting the retaining screws (2).
Insert the rod (4) inside the master cylinder (3), after applying the recommended grease.
Tighten screws (2) to a torque of 10 Nm \pm 10%.

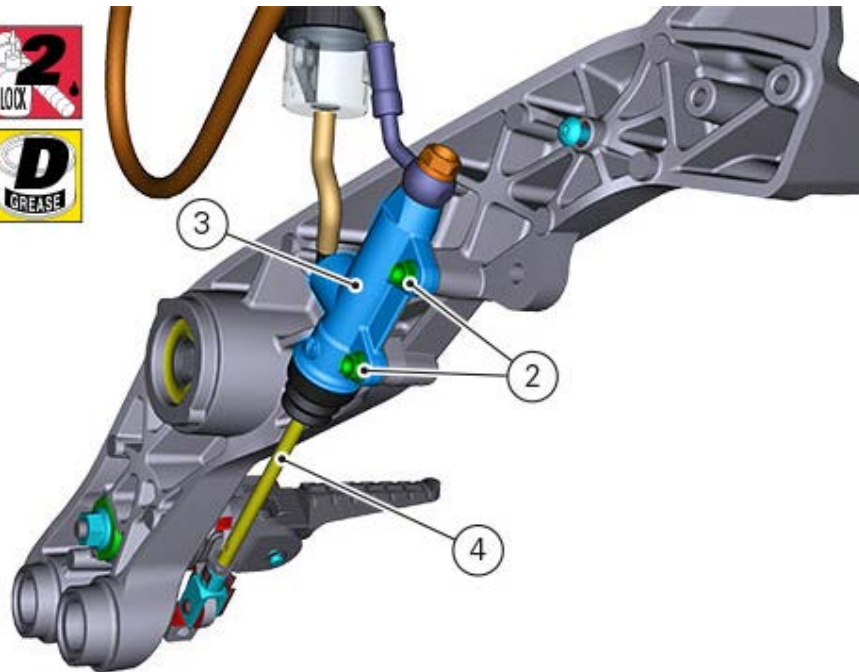

Connect rear stop switch (1) to main wiring.

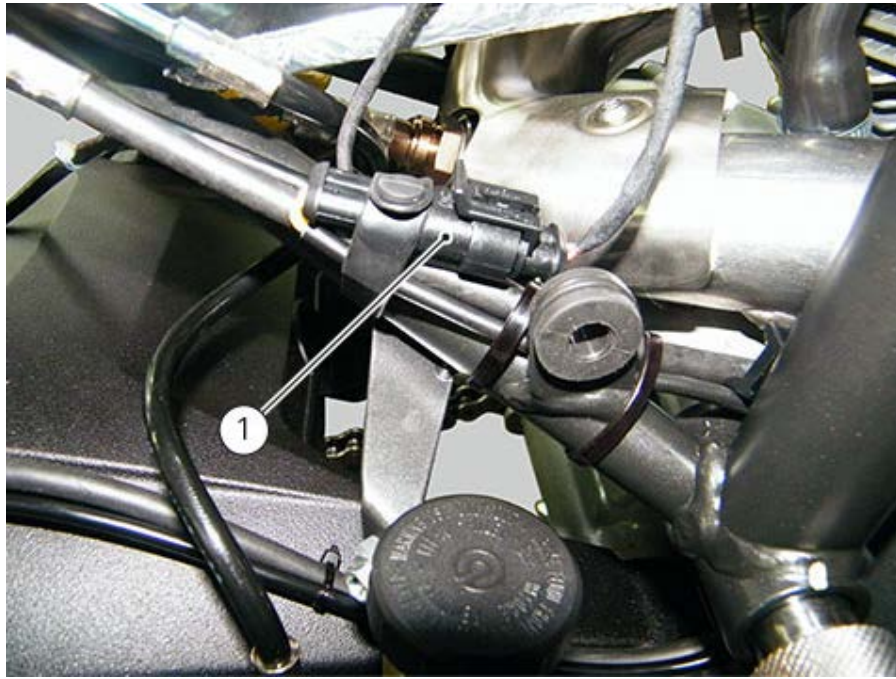

Fill the rear braking system ([Changing the rear brake system fluid](#)).

Disassembling the rear brake control

The brake master cylinder is supplied only as a complete unit; internal components cannot be replaced. To disassemble the master cylinder's outer parts, follow the indications given in the exploded view at the beginning of this Section.

If the bush (10) inside the brake pedal (6) needs to be replaced, grease the external surface and fit the new bush using a press to insert it. The bush must be placed at 2 mm from the pedal external face.

To disassemble the various parts of the system, refer to the exploded view at the beginning of this chapter.

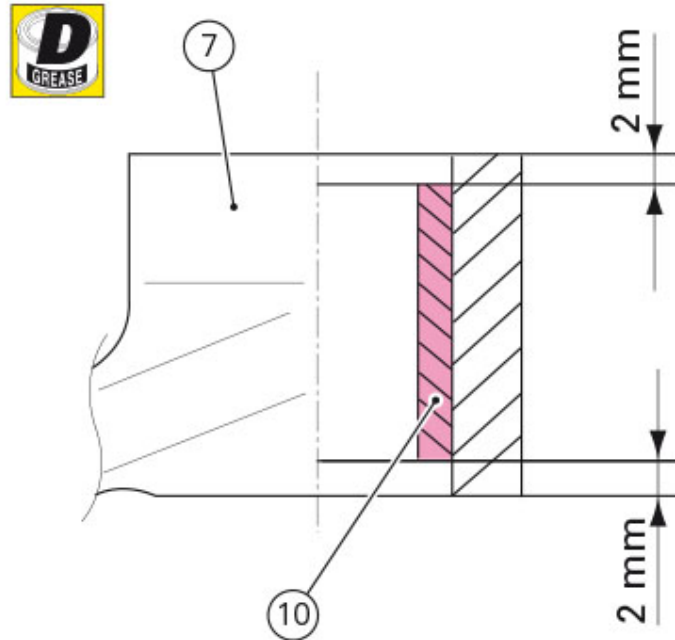

After performing an operation on the rear brake control, check the brake pedal position following the instructions detailed in Section "[Adjusting the position of the gear pedal and rear brake pedal](#)".

Removing the rear brake control

Warning

The brake master cylinder manufacturer advises against servicing the brake master cylinder due to the safety critical nature of this component. Incorrect overhaul can endanger rider and passenger safety. Maintenance operations on these units are limited to replacement of the following parts: control lever, fluid reservoir assembly and relative fasteners and master cylinder fasteners.

Drain the rear braking system ([Changing the rear brake system fluid](#)).

Remove the footpeg holder plate.

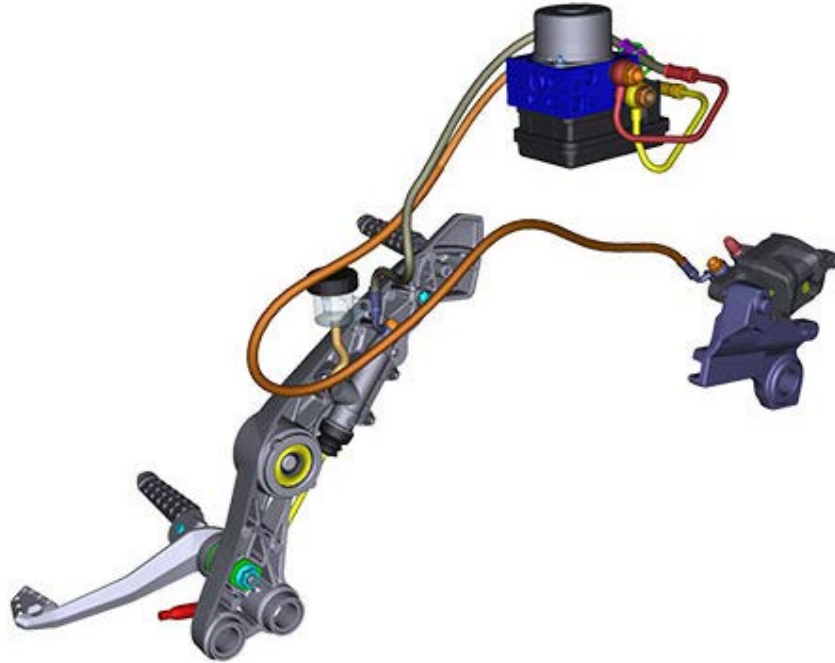

Disconnect rear stop switch (1) from main wiring.

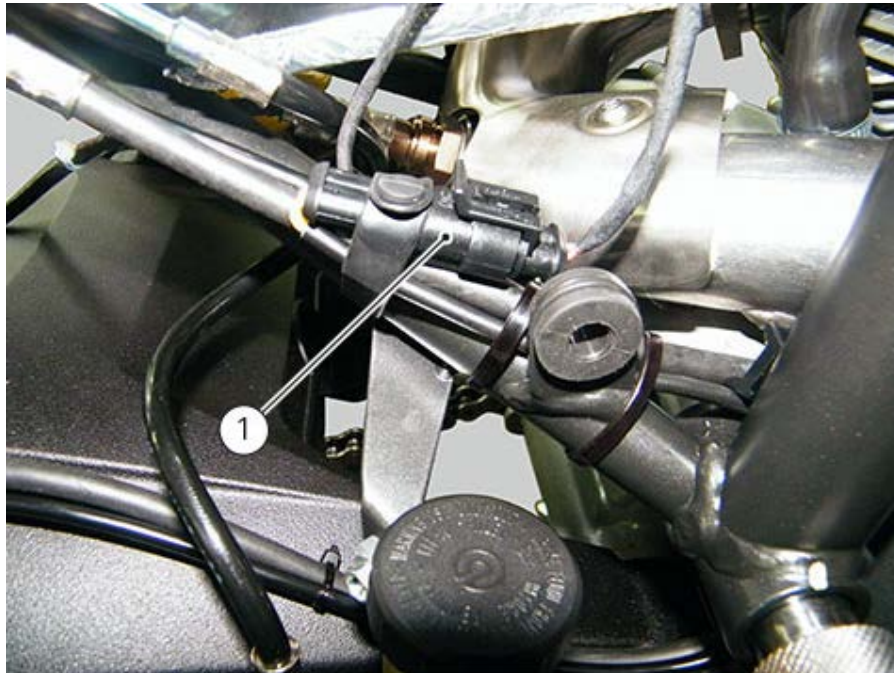

Loosen rear brake master cylinder retaining screws (2). Slide out rear brake master cylinder (3) from adjuster rod (4).

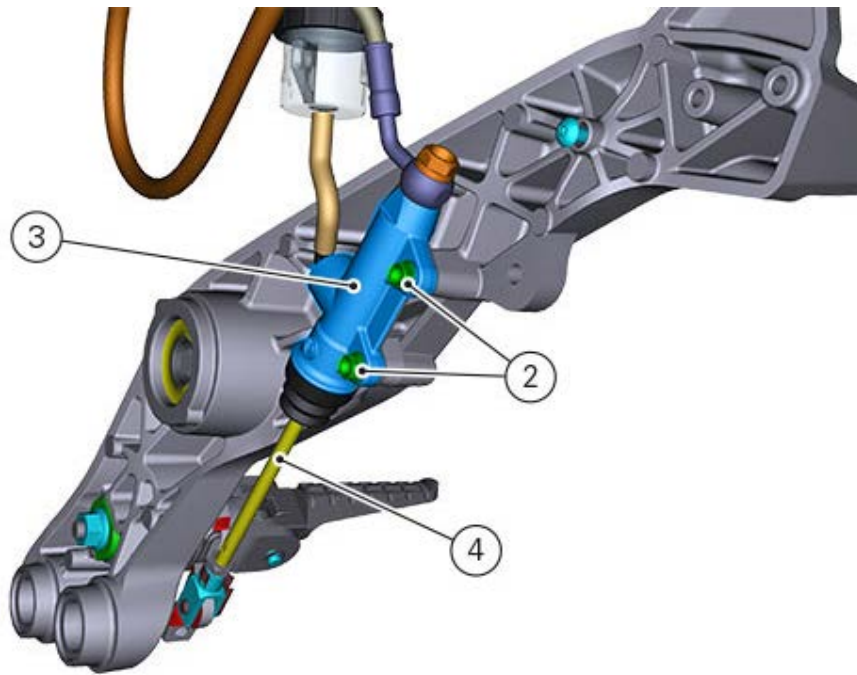

Loosen nut (5) securing the RH footpeg (6).

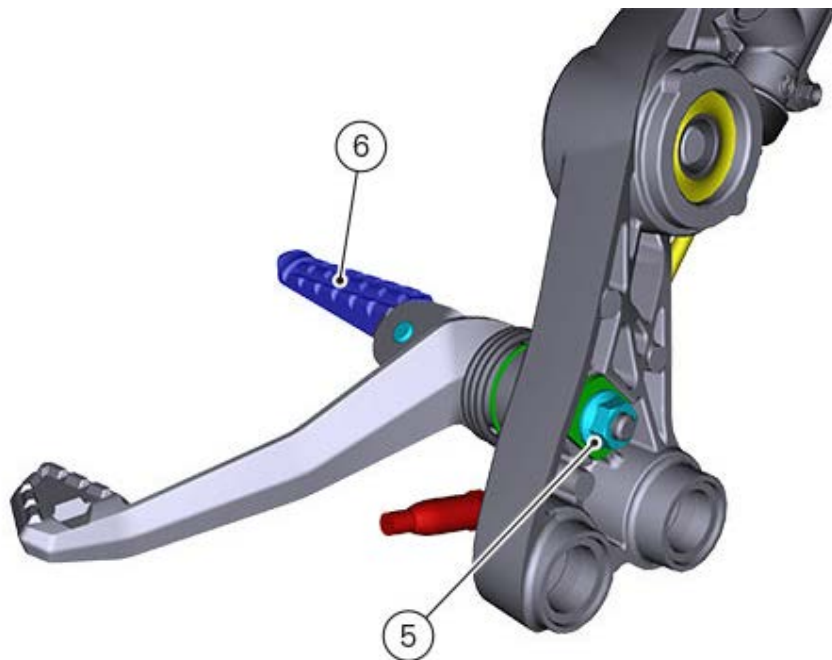

Slide out brake control lever (7) and footpeg (6) of the footpeg holder plate (8).
Collect washer (9).

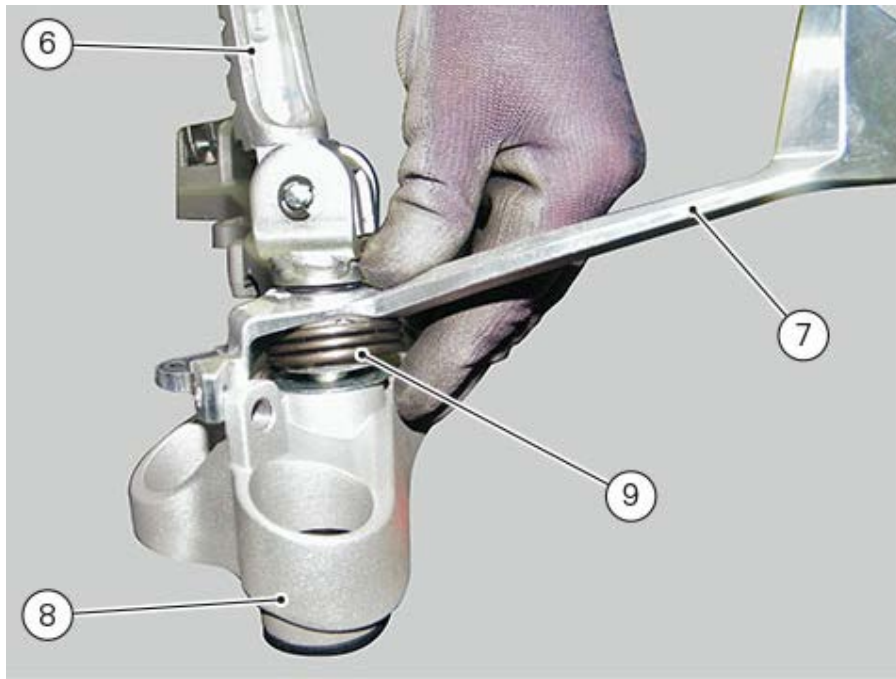

Separate bracket (6) and lever (7).

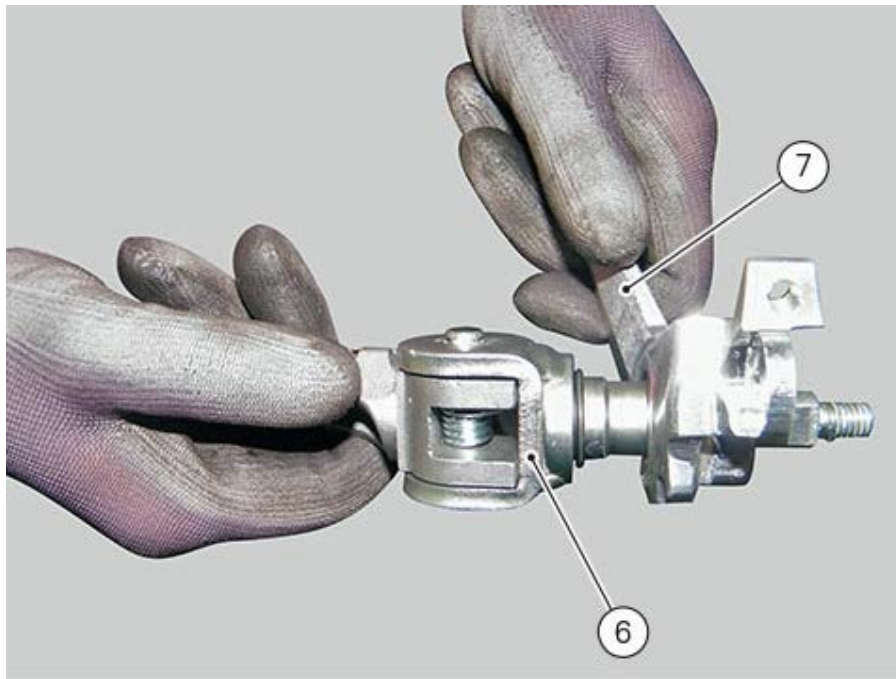

Undo special screw (12) from master cylinder (3) and slide out hose (11), collecting seals (12). Remove rear brake master cylinder (3) from vehicle.

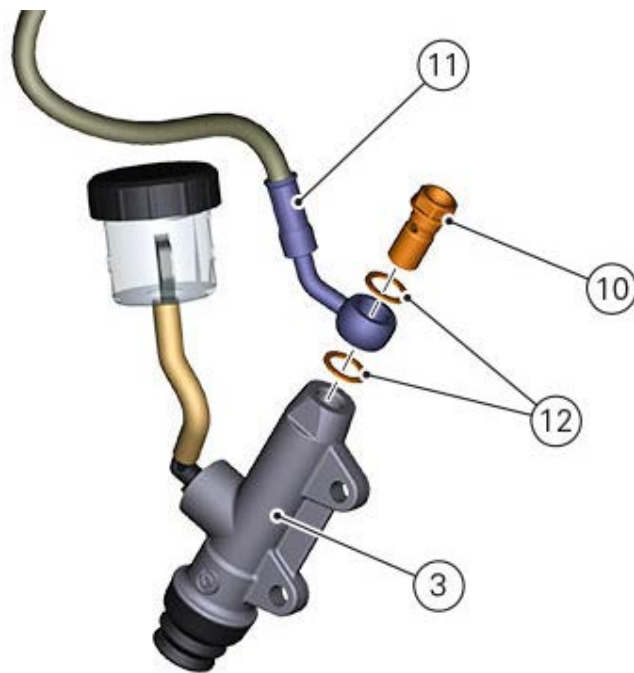

Routing wiring harnesses/hoses

TABLE	POSITION	DESCRIPTION
TABLE A - TABLE B	1	ABS control unit
TABLE A - TABLE B - TABLE C - TABLE D	2	Front brake master cylinder
TABLE A - TABLE B - TABLE C - TABLE D - TABLE E - TABLE F	3	Front brake calliper hose
TABLE A - TABLE B - TABLE G - TABLE I	4	Rear brake master cylinder
TABLE A - TABLE B - TABLE G - TABLE H - TABLE I	5	Rear brake calliper hose
TABLE D - TABLE E	6	Front speed sensor cable
TABLE G - TABLE H - TABLE I	7	Rear speed sensor cable

TABLE A

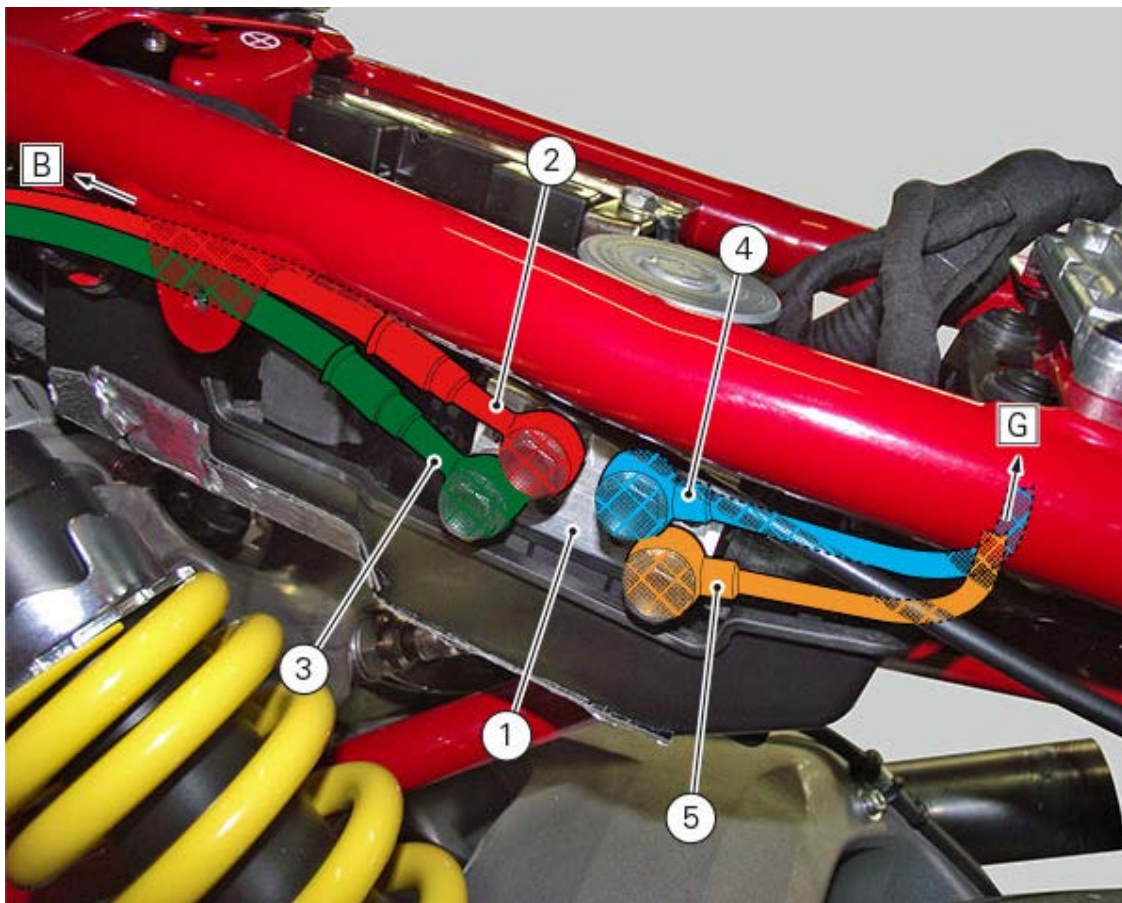

TABLE B

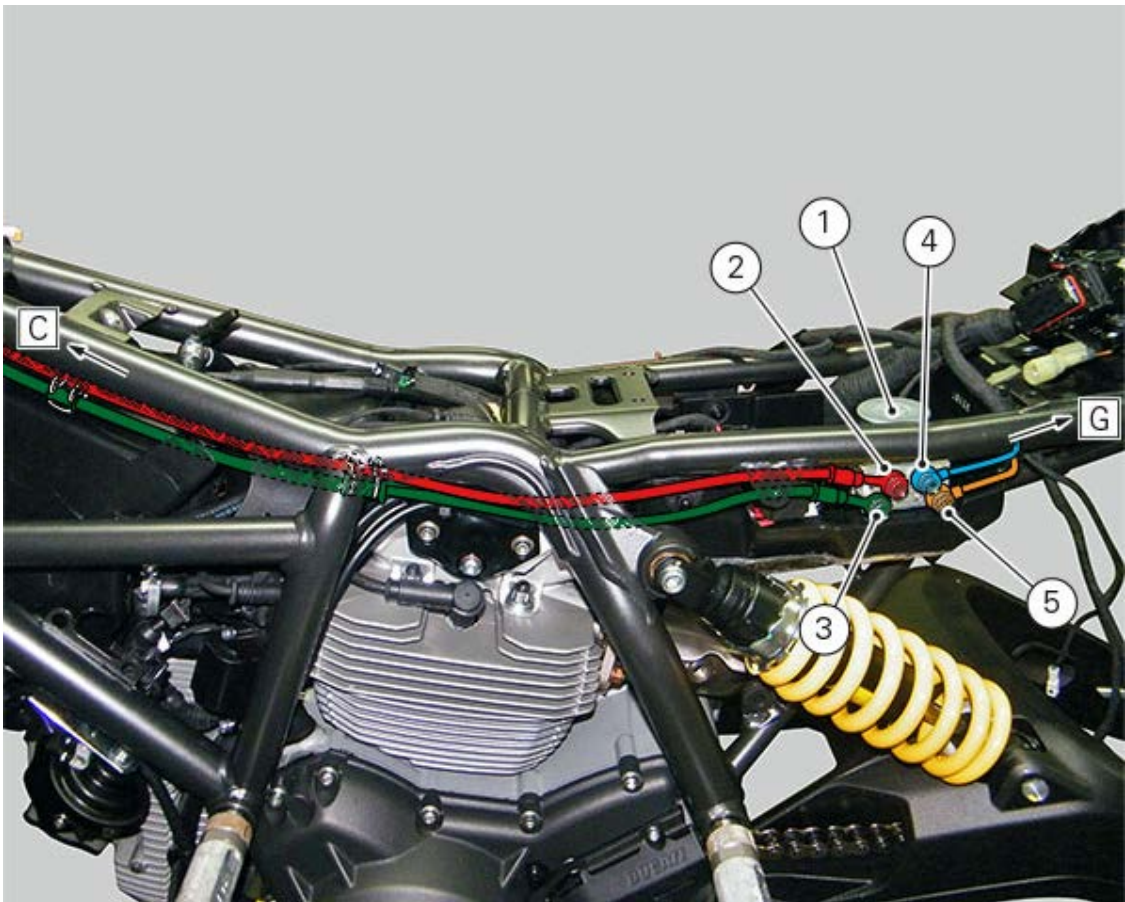

TABLE C

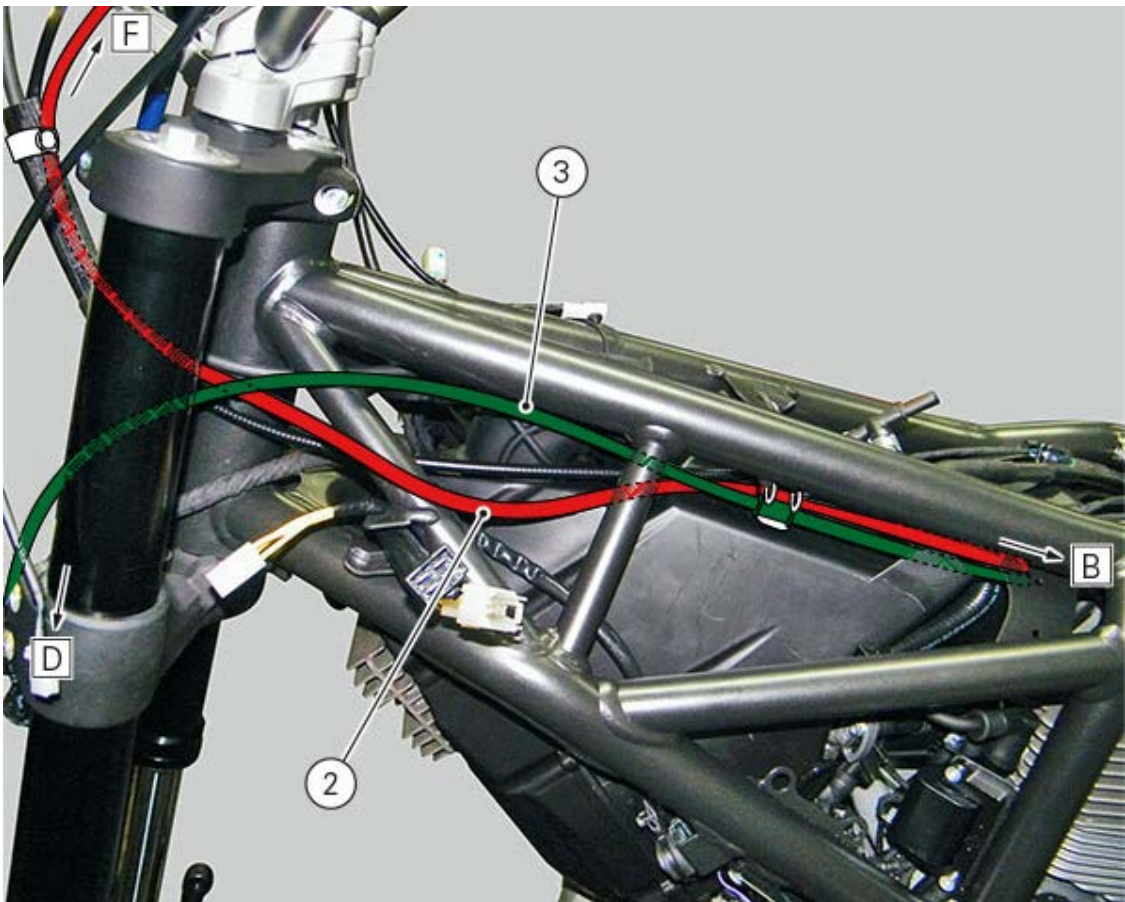

TABLE D

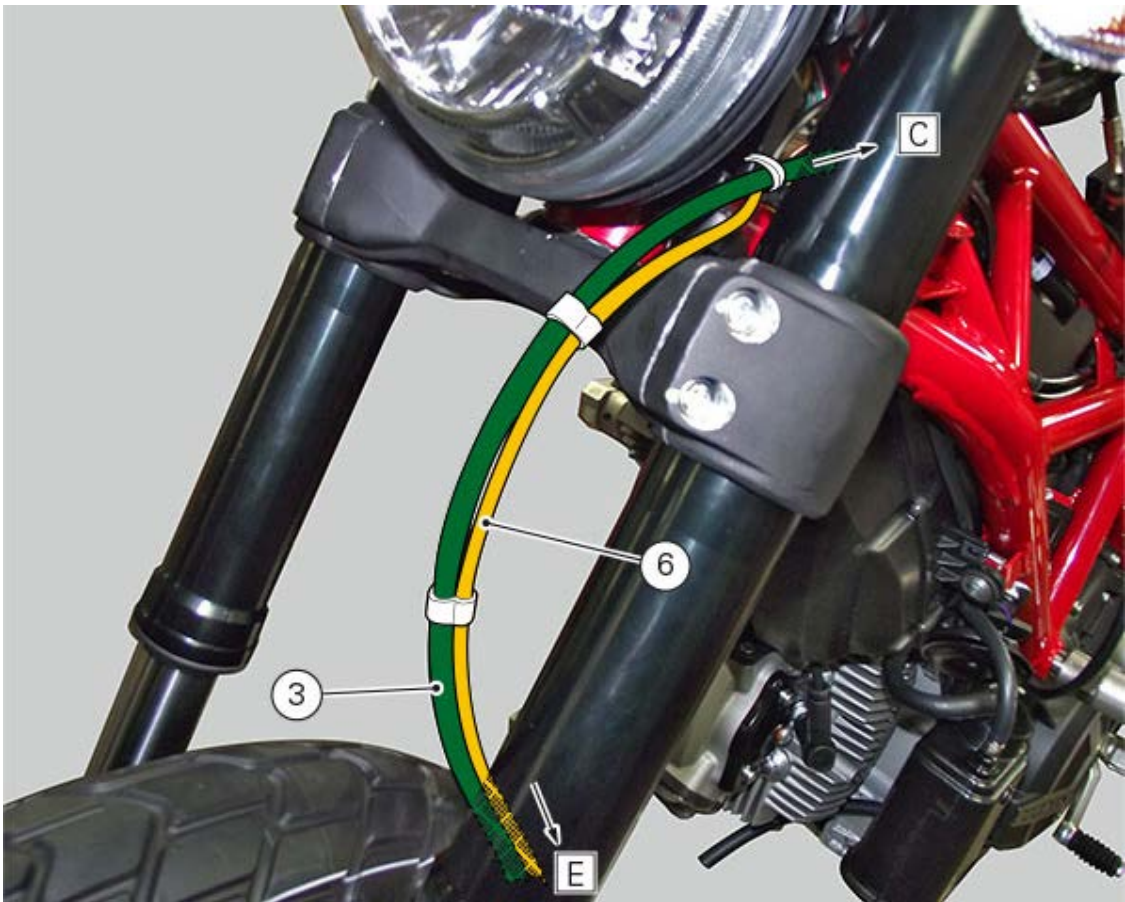
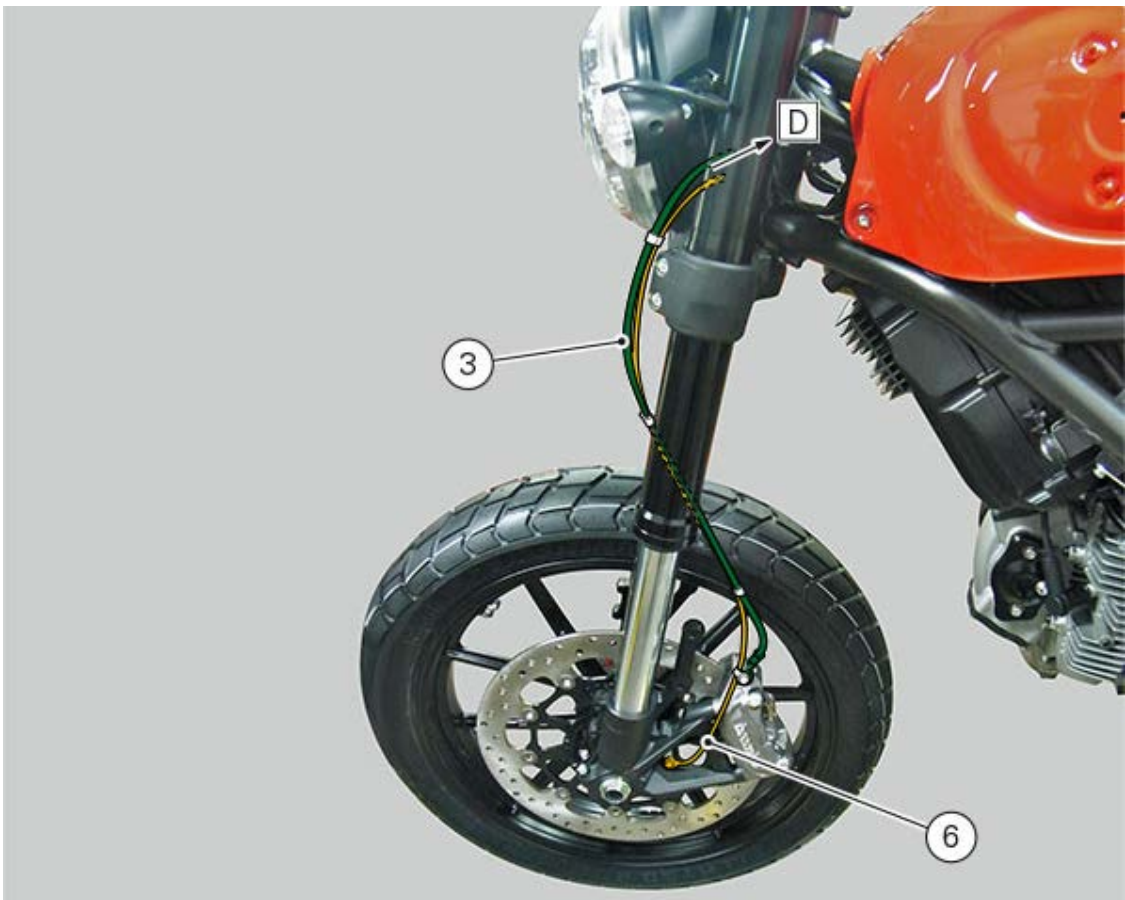

TABLE E



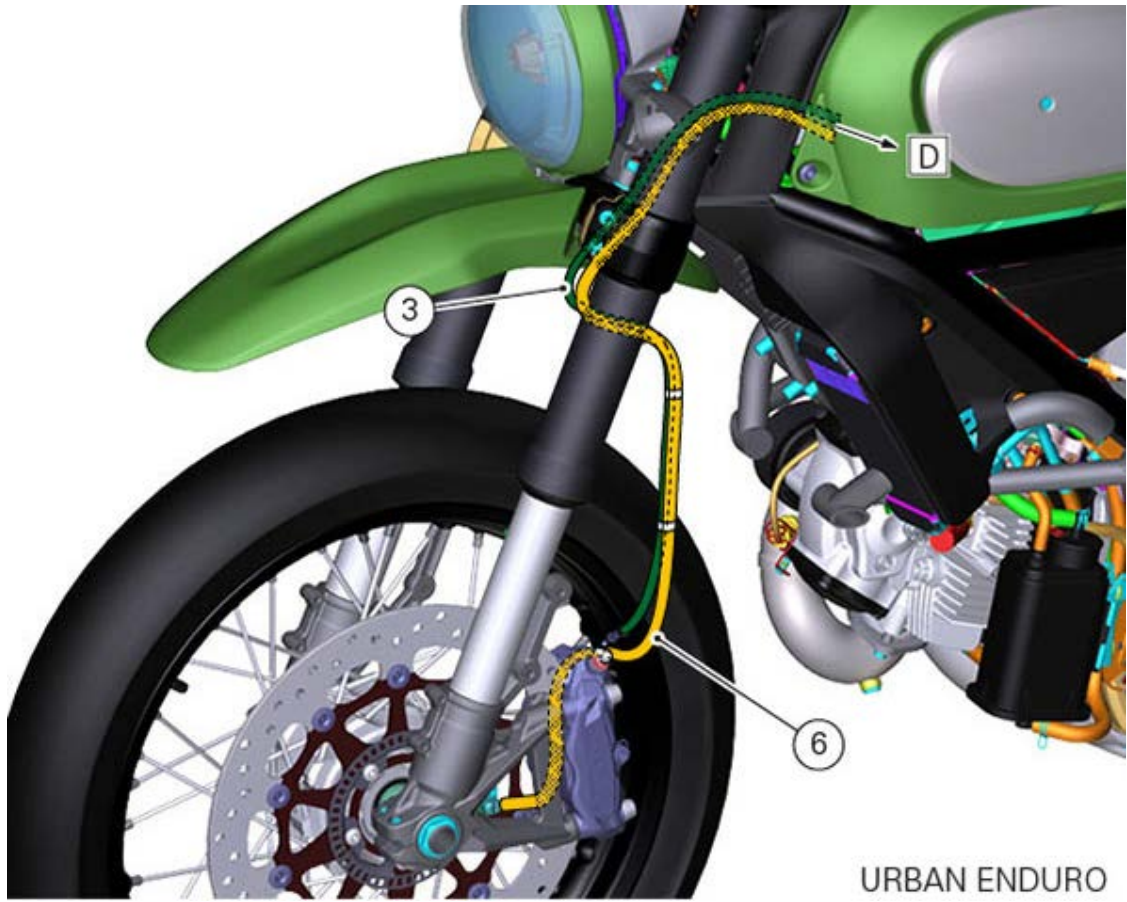

TABLE F

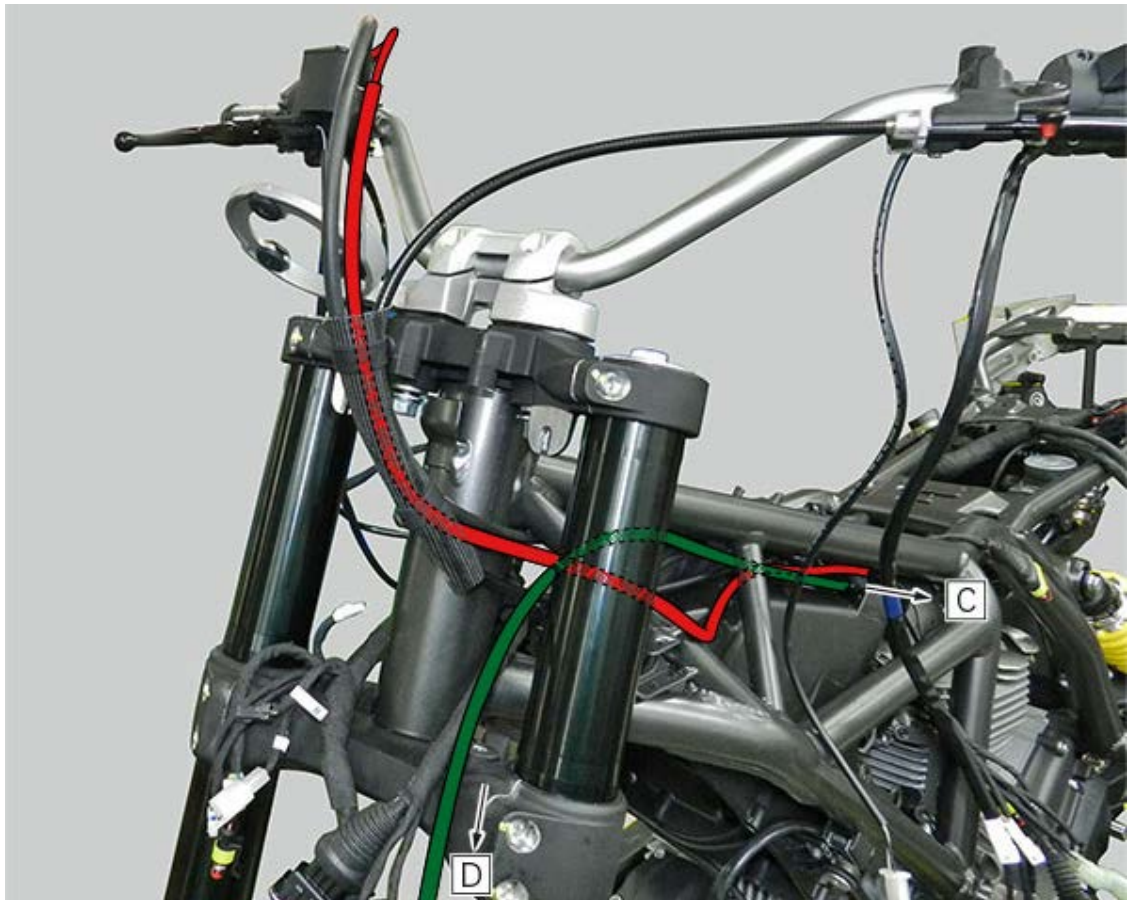

TABLE G

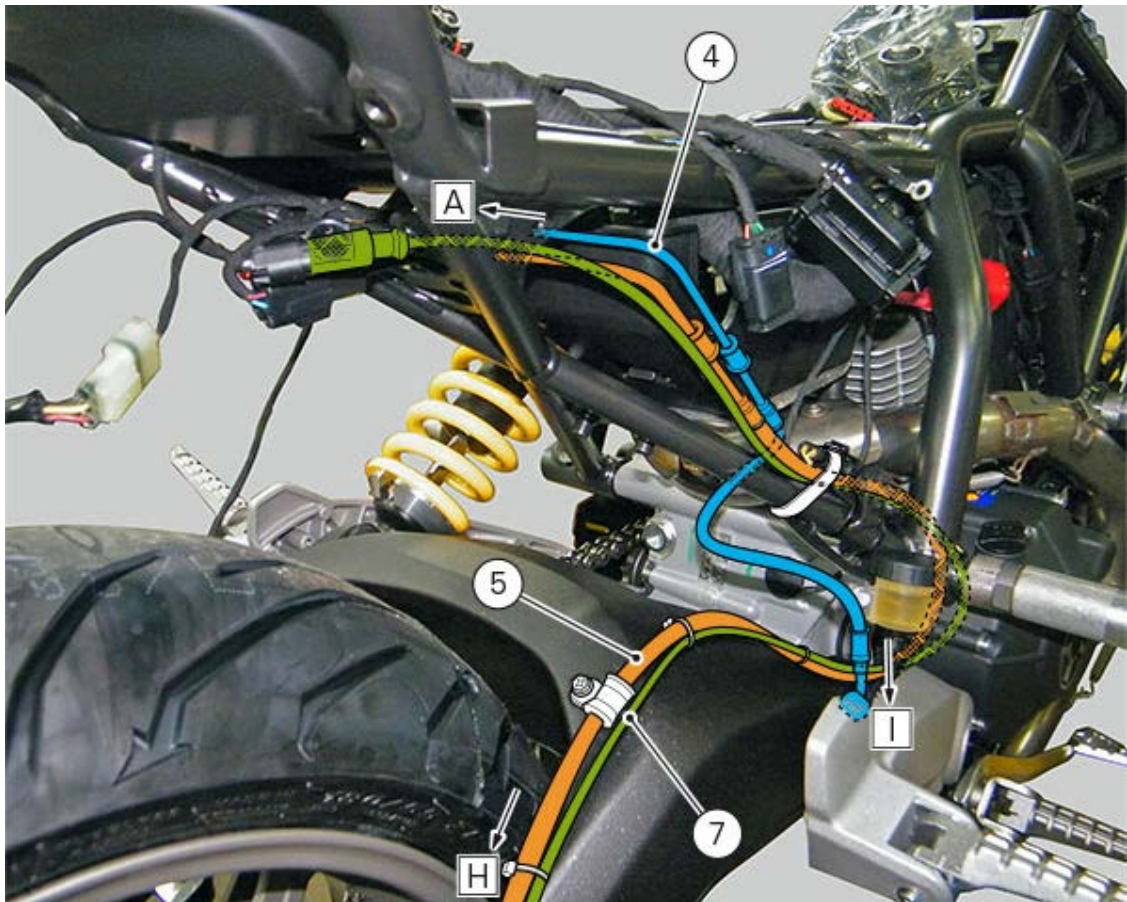

TABLE H



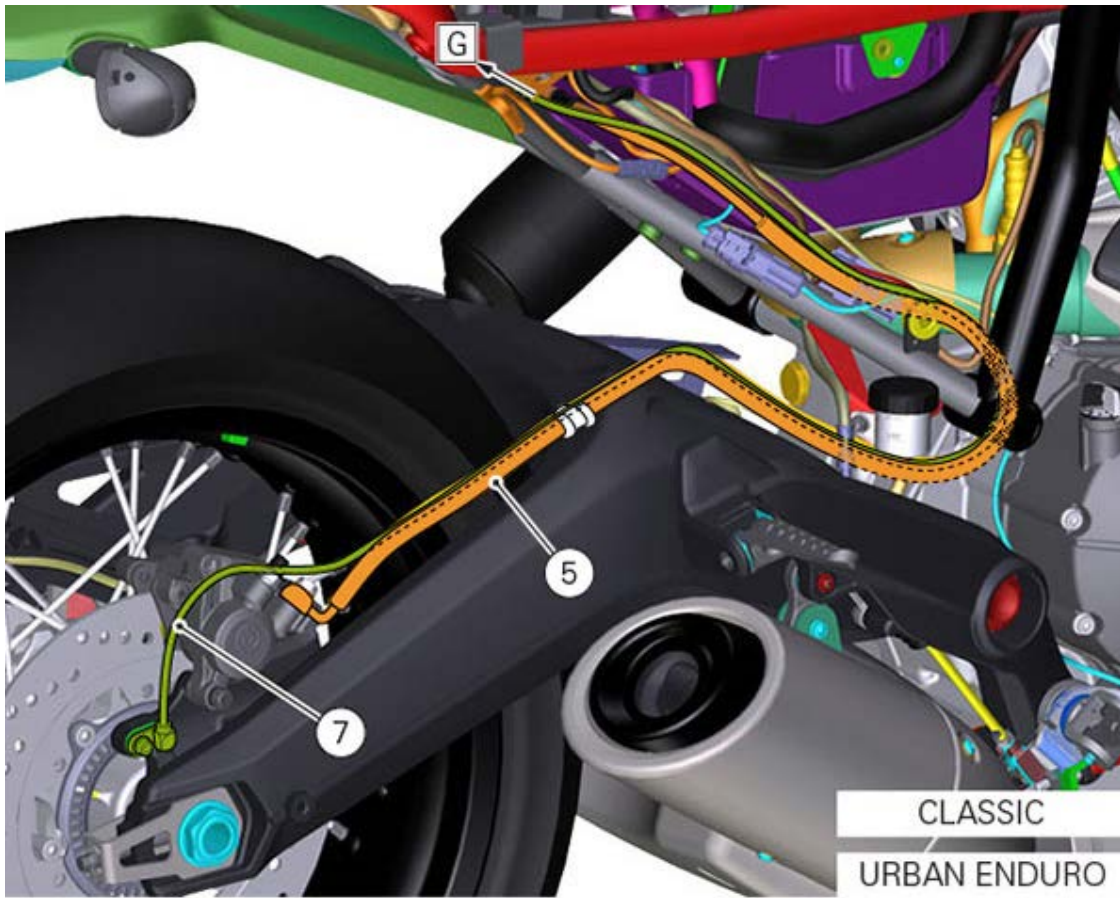
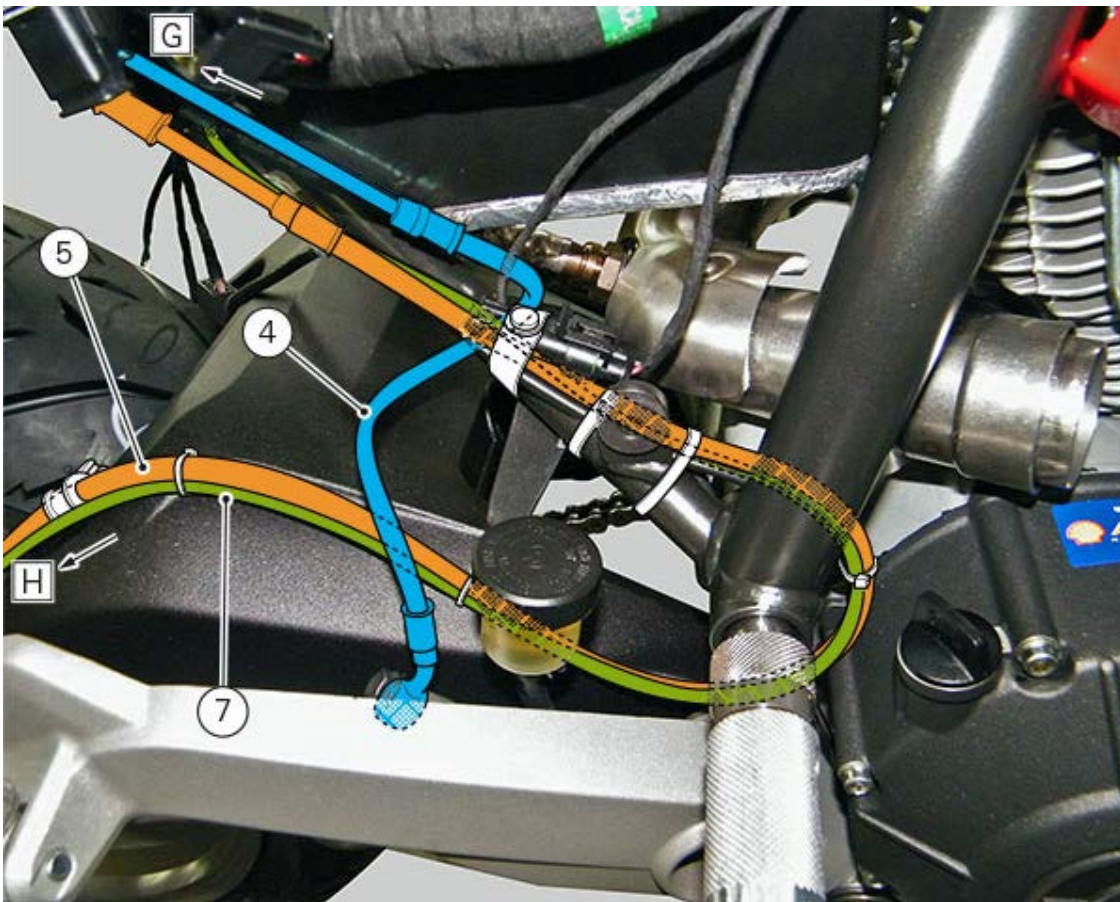

TABLE I



Refitting the ABS control unit

In case of replacement or removal of the hoses (3), (4), (5) and (6) on the ABS control unit, it is necessary to pay special attention to the union position on the control unit.

Warning

If incorrectly positioned, hoses can affect brake operation and foul moving parts. Position the component as shown in the figure.

X=77°
Y=90°
Z=5°

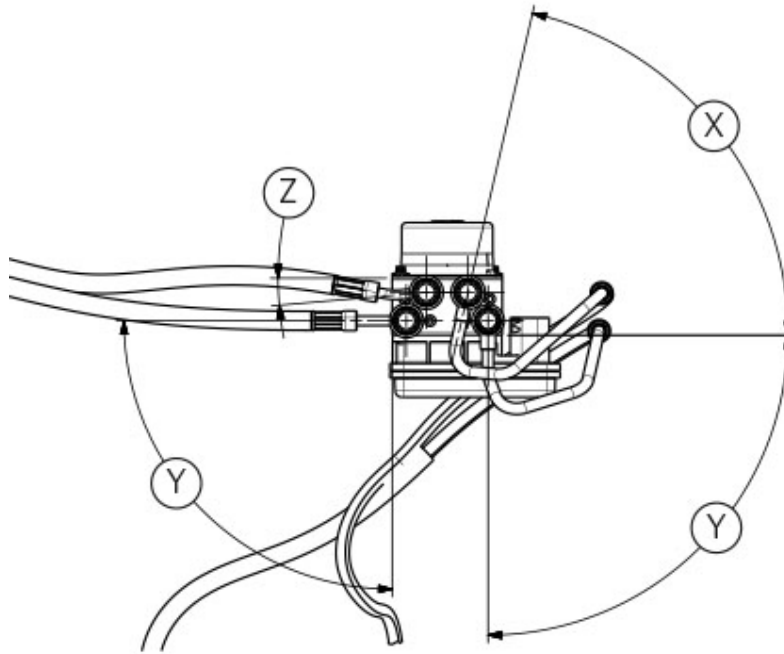

Hoses (3), (4), (5) and (6) must be secured in place using new sealing washers (2) on unions.
Fasten the ABS control unit (8) by tightening the screws to the torque of 6.8 Nm \pm 10%.
Tighten screws (1) securing the hoses indicated below to the ABS control unit to a torque of 23 Nm \pm 10%:

ABS control unit hose to front brake master cylinder (3);
ABS control unit hose to front brake calliper (4);
ABS control unit hose to rear brake master cylinder (5);
ABS control unit hose to front brake calliper (6).

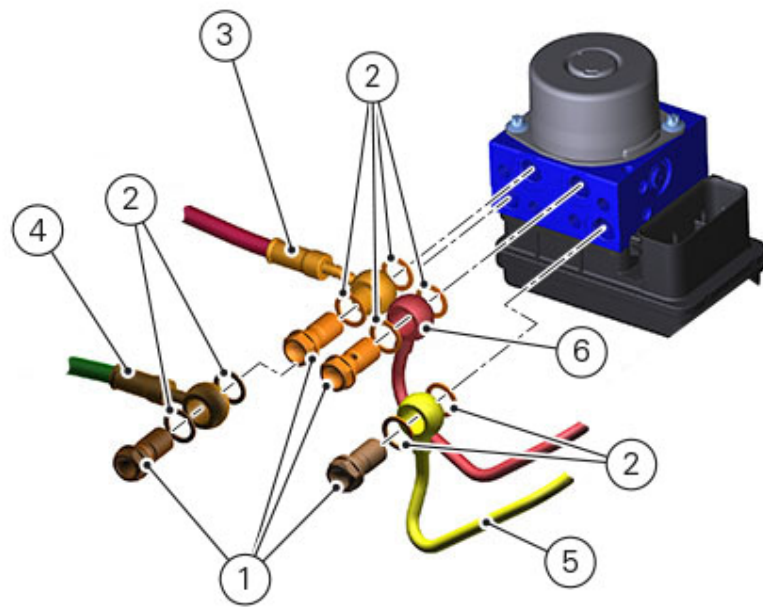

Removing the ABS control unit

Remove the seat ([Removing the seat](#)).

Remove the fuel tank ([Removing the fuel tank](#)).

Remove the battery.

Remove the front brake system ([Removing the front brake system](#)).

Remove the rear brake system ([Removing the complete rear brake control](#)).

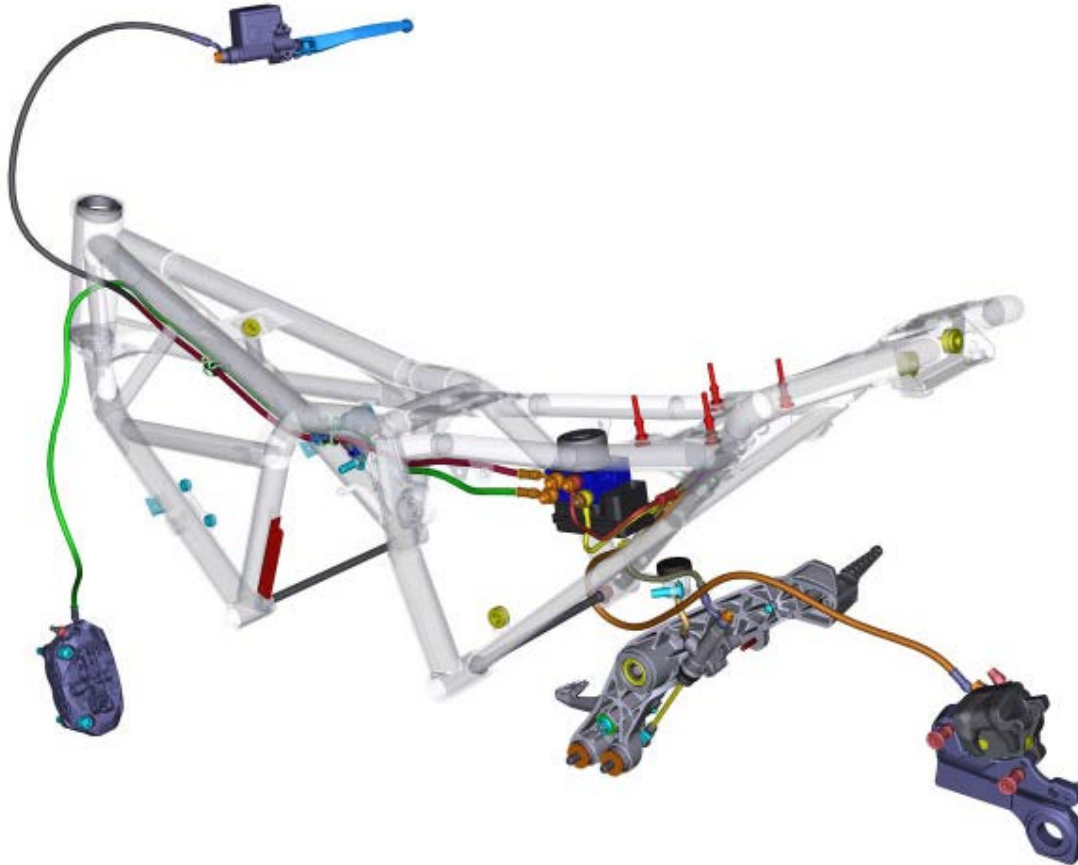

Loosen special screws (1), collect seals (2) and remove the following hoses:

(3) Front brake master cylinder;

(4) Front brake calliper;

(5) Rear brake master cylinder;

(6) Rear brake calliper.

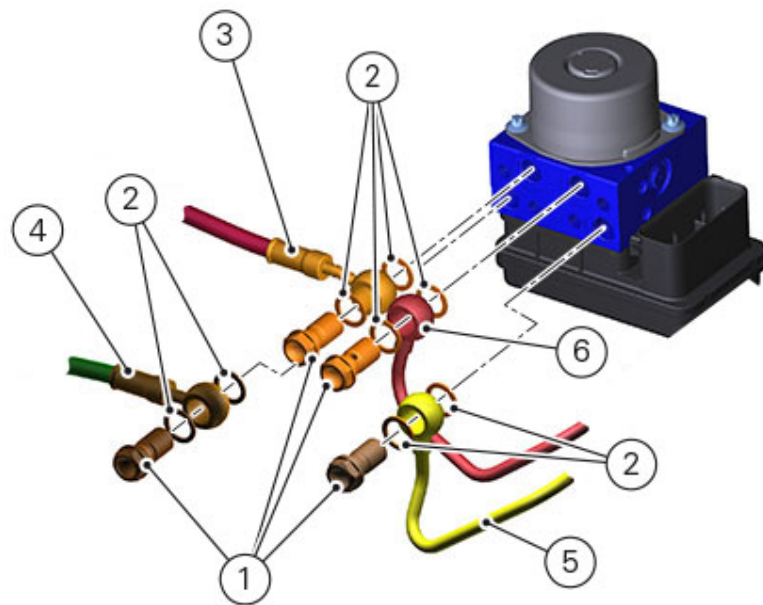

Disconnect the connector (11).

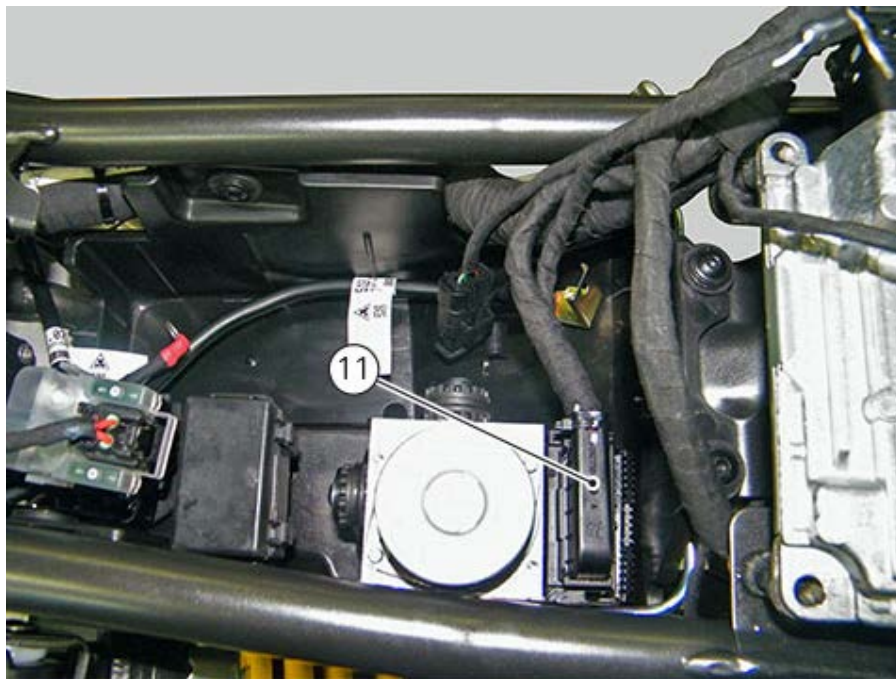

Remove the ABS control unit (7), loosening the two screws (8).

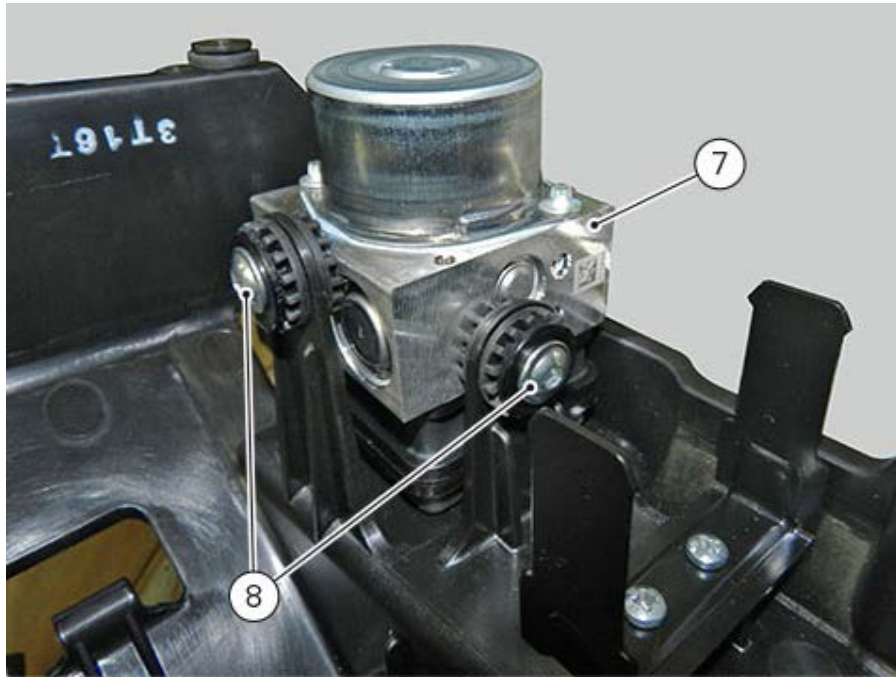

Release the two hoses (3) and (4) from cable ring (9).

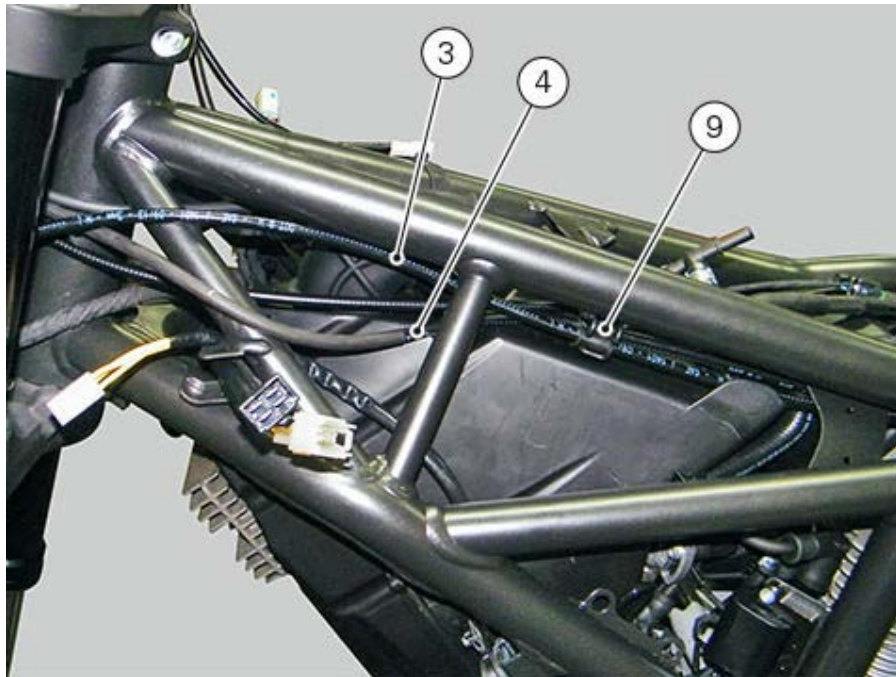

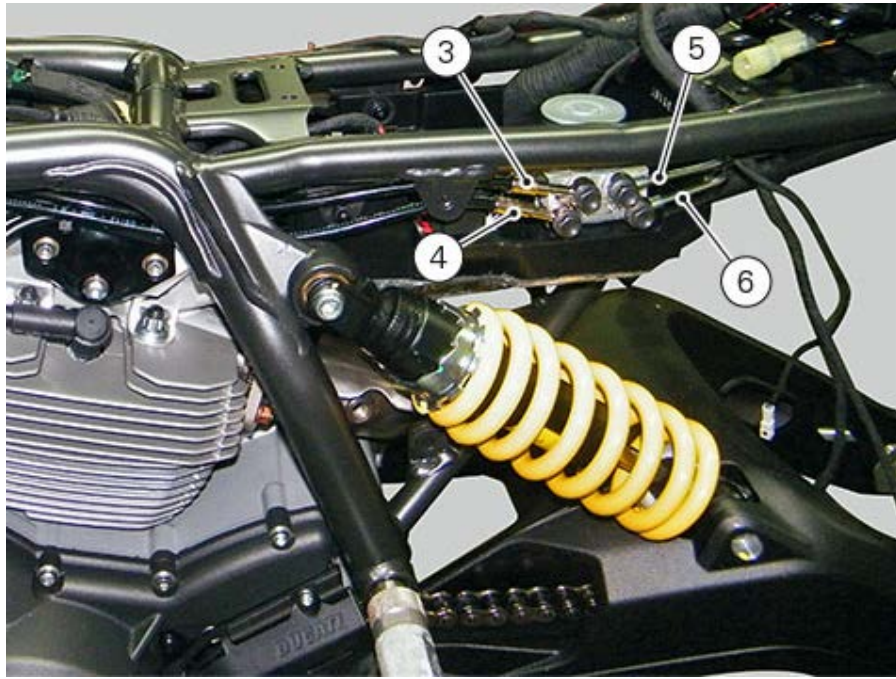

Release the brake hose (6) from the clip (10).



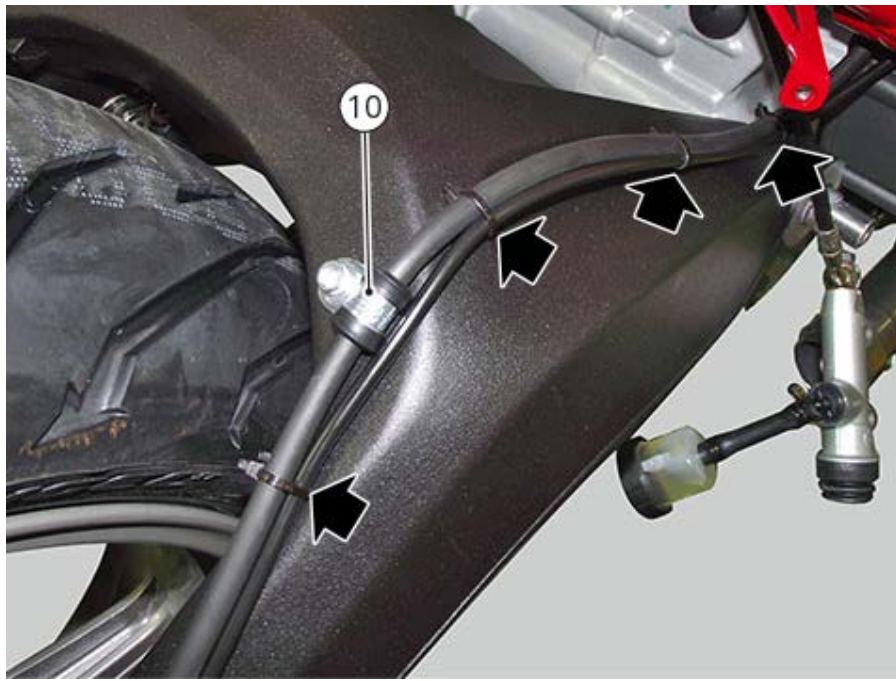

Changing the rear phonic wheel sensor

REMOVAL PROCEDURE

Disconnect connector (1) of rear ABS sensor from electric wiring. Open all clips retaining rear ABS sensor cable: refer to tables under Section "[Routing wiring harnesses / hoses](#)".

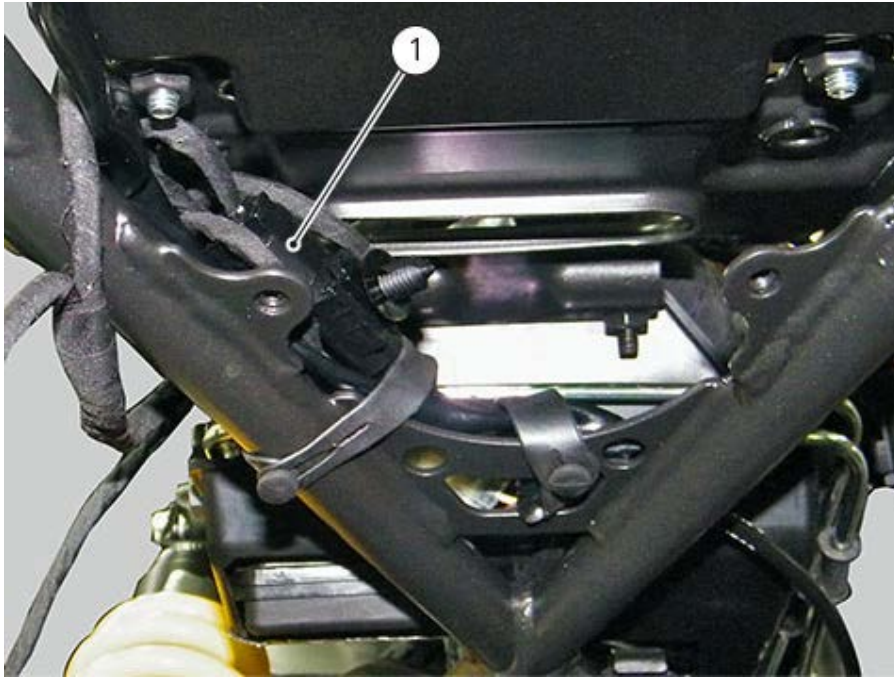

Remove the rear ABS sensor (2) from its seat on rear calliper holder plate (3), by loosening retaining screw (4) and collecting calibrated sealing washer (5). Check air gap between new rear ABS sensor (2) and rear phonic wheel as explained under: "[Adjusting the AIR-GAP of phonic wheel sensor](#)". Fasten the sensor to the calliper holder plate by tightening screw (4) to a torque of 7 Nm \pm 10%.

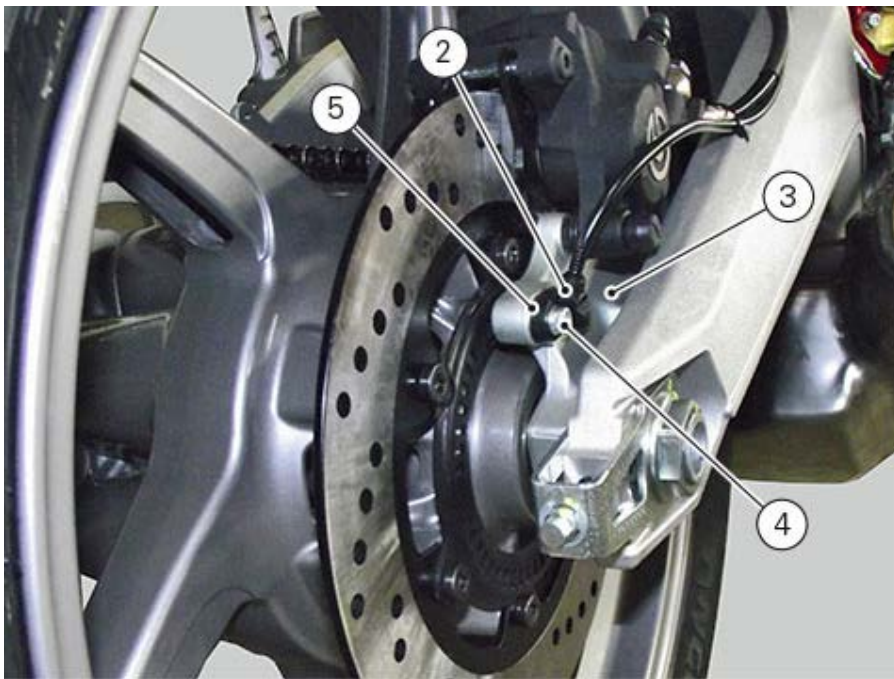

REFITTING PROCEDURE

Connect connector (1) to main wiring. Fasten all clips retaining rear ABS sensor cable: refer to tables under Section "[Routing wiring harnesses / hoses](#)".

Changing the front phonic wheel sensor

REMOVAL PROCEDURE

Disconnect front ABS sensor (2) connector (1) from main wiring.



Open all clips retaining front ABS sensor cable (1): refer to tables under Section: "[Routing wiring harnesses / hoses](#)".

Undo the retaining screw (3), and remove front ABS sensor (2) with calibrated gasket (4), sliding cable out from cable grommet.



REFITTING PROCEDURE

Before refitting, make sure that contact parts between front ABS sensor (2) and its seat are free of damage and perfectly clean. Fit the new front ABS sensor (2) on its seat inserting the screw (3). Check air gap between front ABS sensor (2) and front phonic wheel as explained under Section "[Adjusting the AIR-GAP of phonic wheel sensor](#)".

Tighten screw (3) to a torque of 7 Nm \pm 10%.

Connect connector (1) to main wiring. Fasten all clips retaining front ABS sensor cable (1): refer to tables under section "[Routing wiring harnesses / hoses](#)".



Bleeding of the ABS hydraulic system

If brake controls feel "spongy" due to the presence of air bubbles in the system, bleed as usual, as described in Section ([Changing the front brake system fluid](#)) and ([Changing the rear brake system fluid](#)). Before bleeding a brake master cylinder, move back the calliper pistons to let any air build-up in the ABS control unit flow into the master cylinder. Purge must be carried out by means of the corresponding unions (1) placed on the callipers and the brake master cylinders.

Important

Do not undo the special screws securing the pipe unions on the ABS hydraulic control unit, unless control unit replacement is necessary.

Important

If the ABS hydraulic control unit has been replaced, it will be supplied with the secondary circuit already filled with fluid. Control unit must thus be assembled and the system filled and drained as a traditional system.



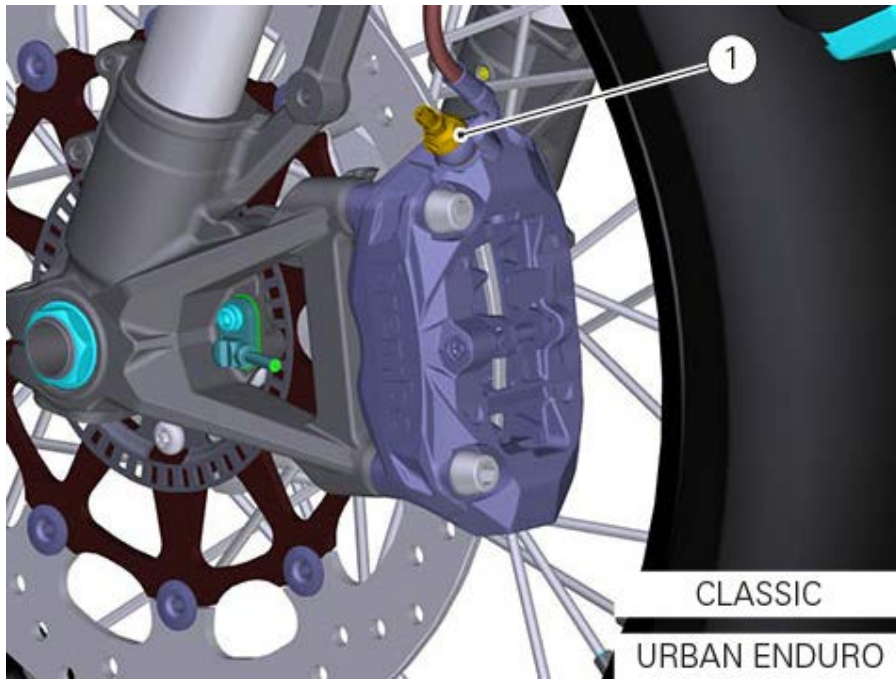

Adjusting the AIR-GAP of phonic wheel sensor

(For front as well as rear sensor) In each case of maintenance that foresees:

- replacing or refitting the wheel;
- replacing or refitting phonic wheel (1) or (2);
- replacing or refitting the brake discs;
- replacing or refitting the speed sensor (3) or (4);
- (front) replacing or refitting the sensor holder bracket;
- (rear) replacing or refitting of the calliper holder plate.

It is necessary to check the air-gap between the speed sensor and the phonic wheel, once the components are refitted.



Note

Perform the test in three points of the phonic wheel, at a distance of 120° one from the other.

To do this, use two feeler gauges (5) of 0.2 mm and 0.5 mm.

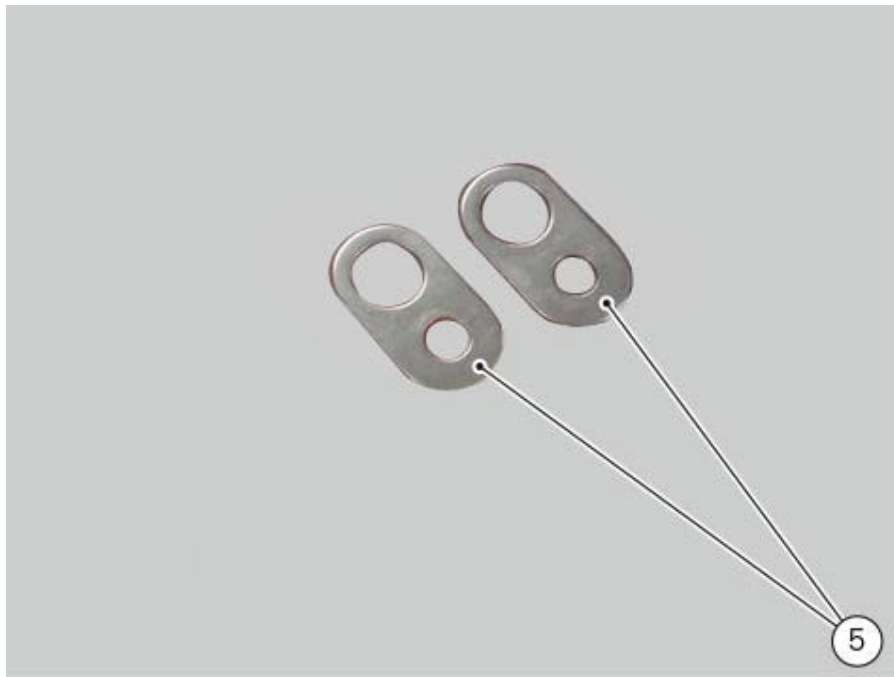

AIR-GAP adjustment procedure

Between front phonic wheel (1) and front ABS sensor (3), and between rear phonic wheel (2) and rear ABS sensor (4) there must be an air-gap between **1.3 mm** and **1.9 mm**.

To check it, use a suitable feeler gauge.



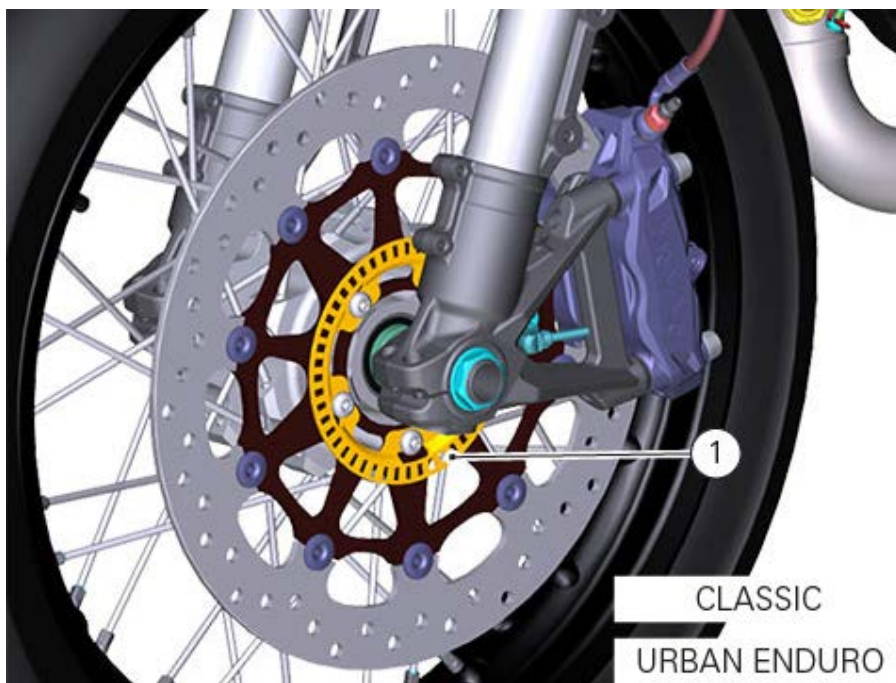
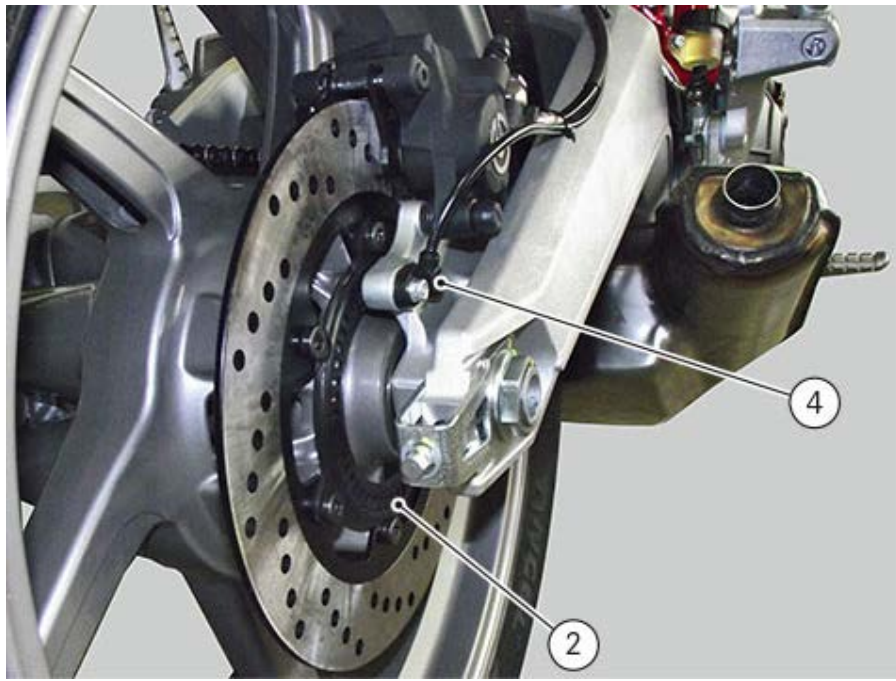

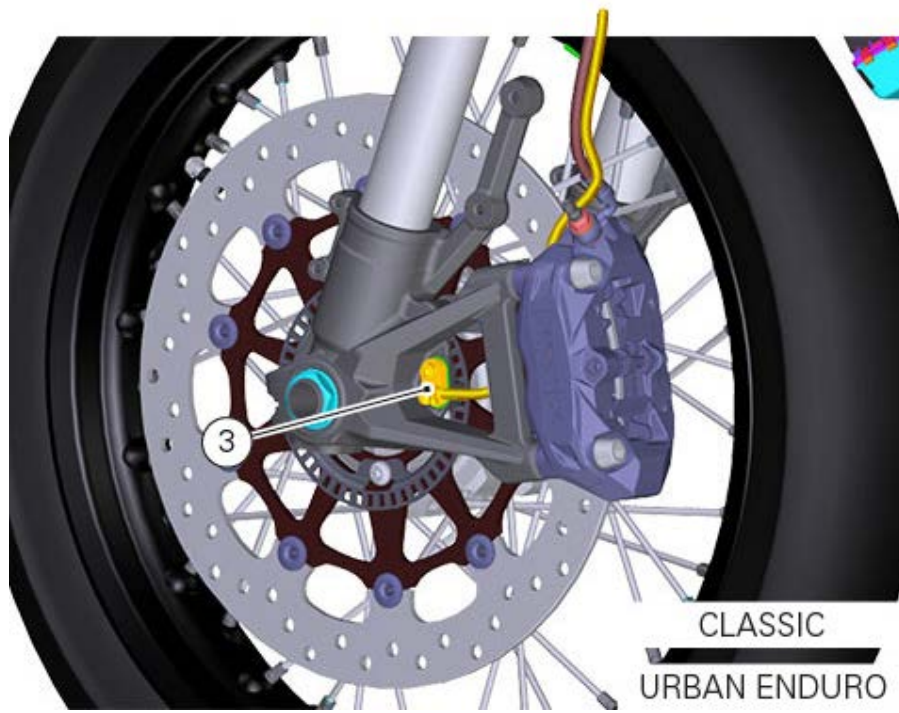

Tighten the sensor securing screw fully home every time you add or remove a shim.
 Measure the AIR-GAP.
 Put the required shims.

Important

The sum of the feeler gauge must never exceed 3 mm.

Once the shimming is completed, tighten the sensor retaining screw to a torque of 7 Nm \pm 10% and check the AIR-GAP again.

Refitting the throttle control

Fit throttle control on handlebar.

Fasten the handlebar as described in chapter "[Refitting the handlebar](#)".

Match the throttle control pin (6) with the handlebar seat (7).

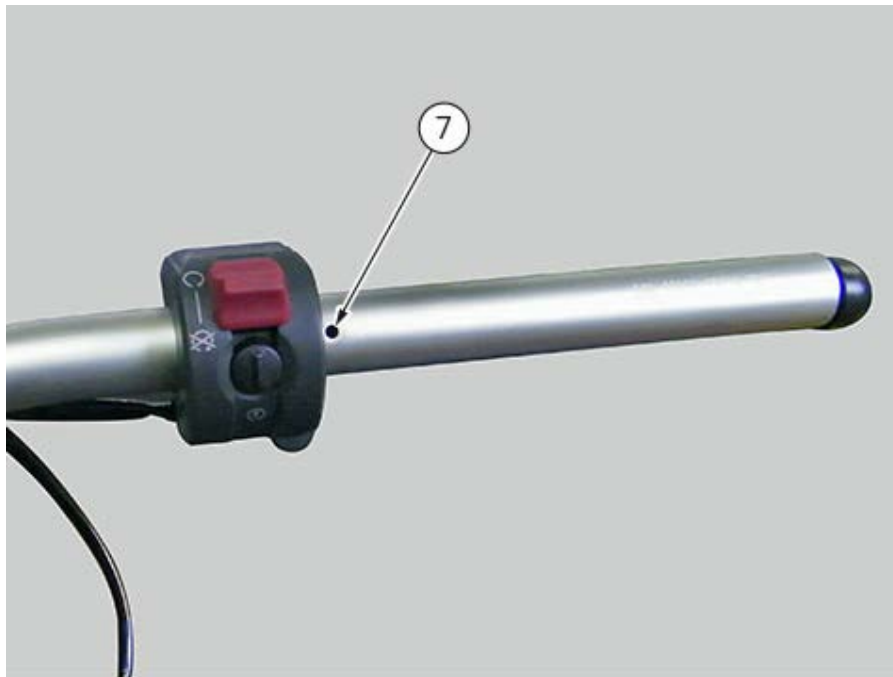

Tighten screws (1) of throttle control (2) to a torque of $6 \text{ Nm} \pm 10\%$.

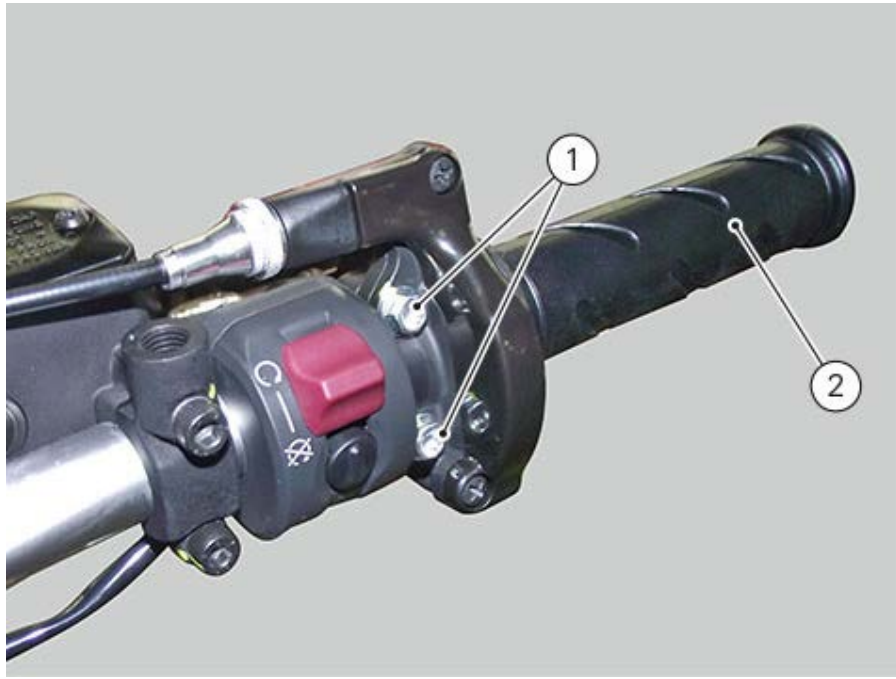

Removing the throttle control

Loosen screws (1) of throttle control (2).

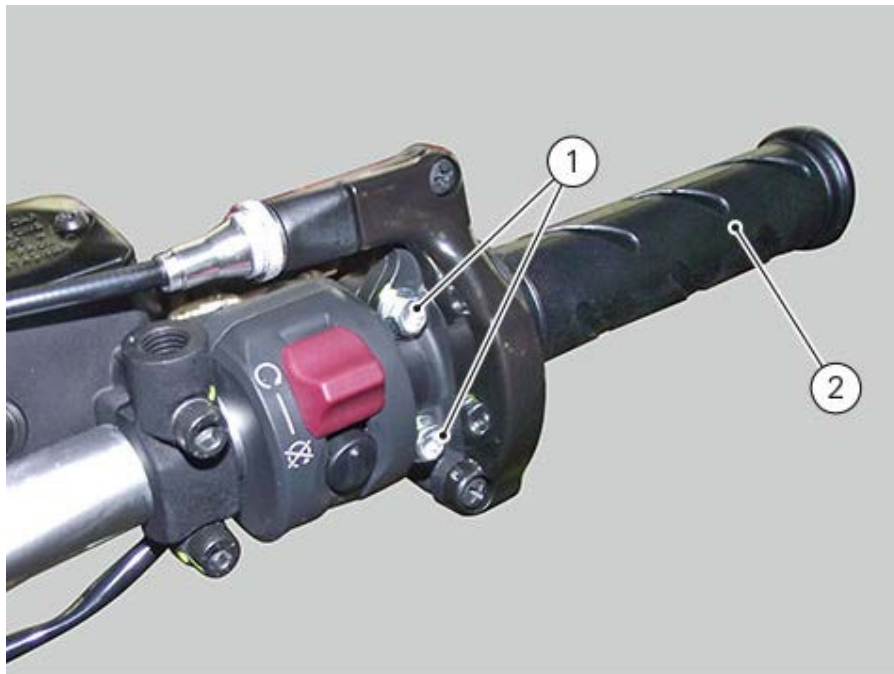

Release handlebar (3) from U-bolt (4) loosening screws (5).
Slide out throttle control (2).

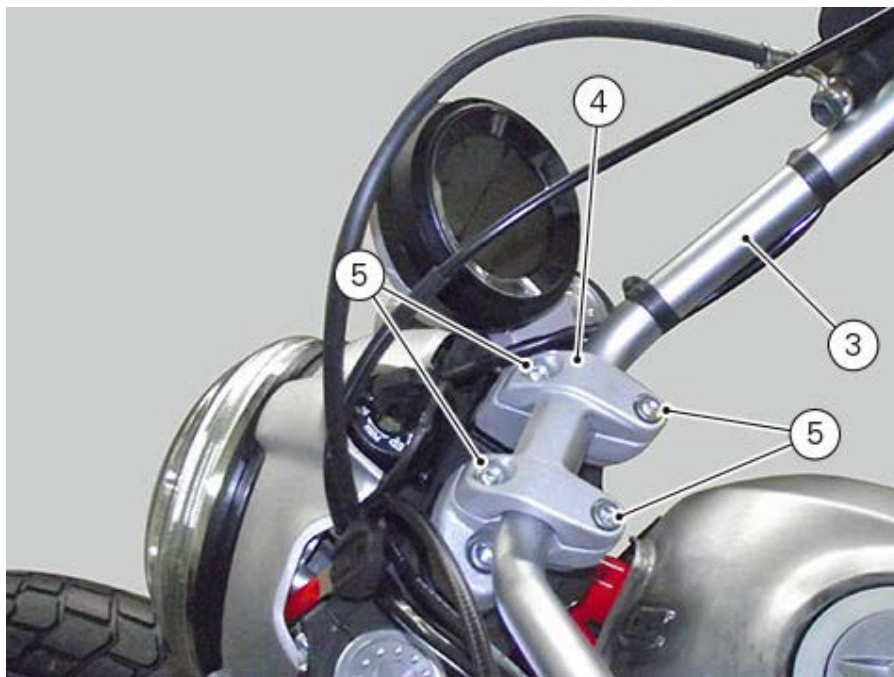

Adjusting the throttle cable

For the throttle control cable adjustment refer to chapter "[Adjusting the throttle cable](#)".

Refitting the handlebar

If previously removed, install the silent blocks (18) in the relevant seats in the steering head (16):

- Aim the silent block (18) as shown in the figure;
- Drive the silent block (18) fully home, in line with its seat.

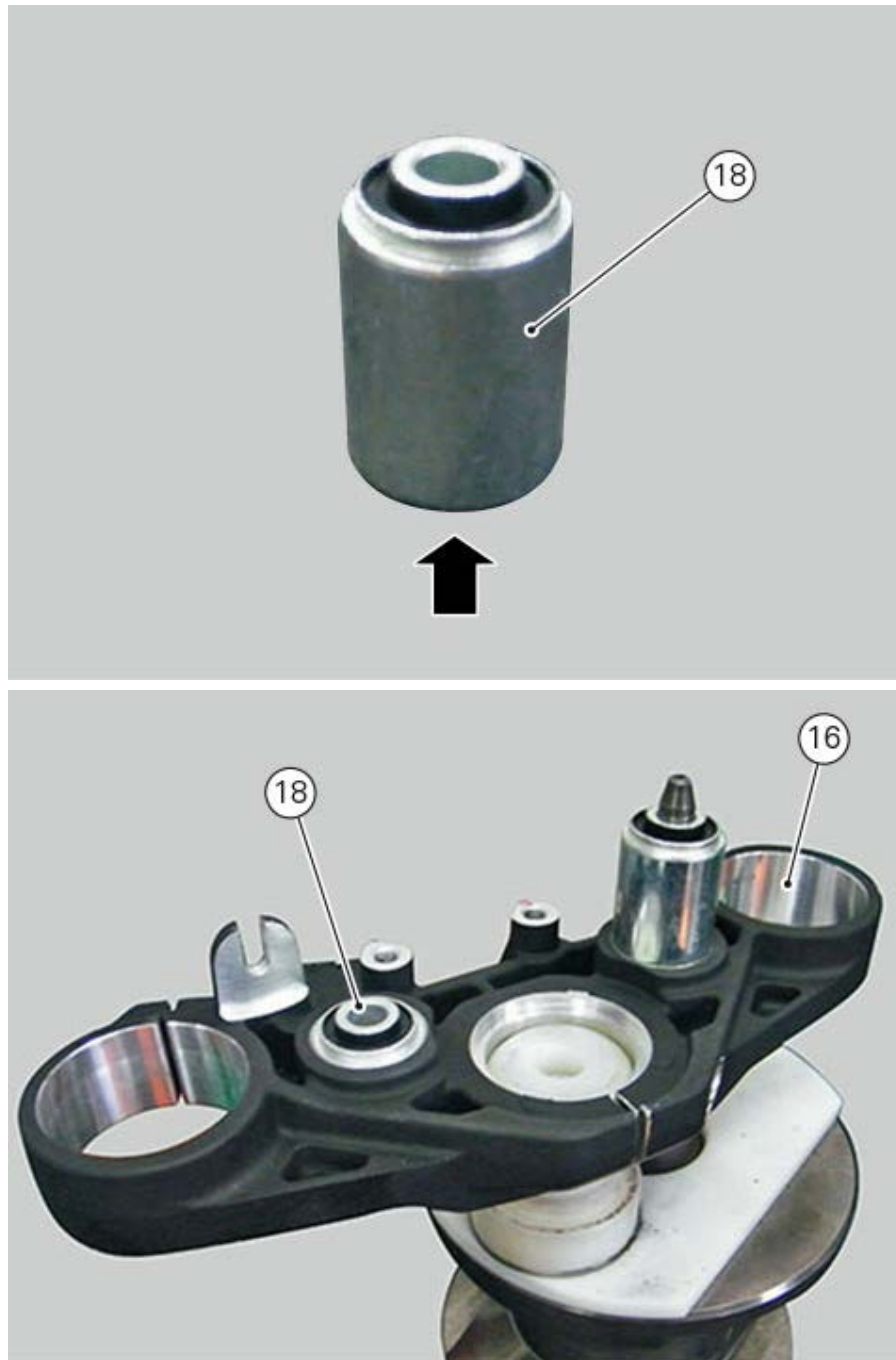

Note

Drive the silent-block by working on the outer ring. Before driving the silent blocks, lubricate them with the indicated product.



Insert the steering head on the two screws (19) and take it fully home against lower U-bolt (17).

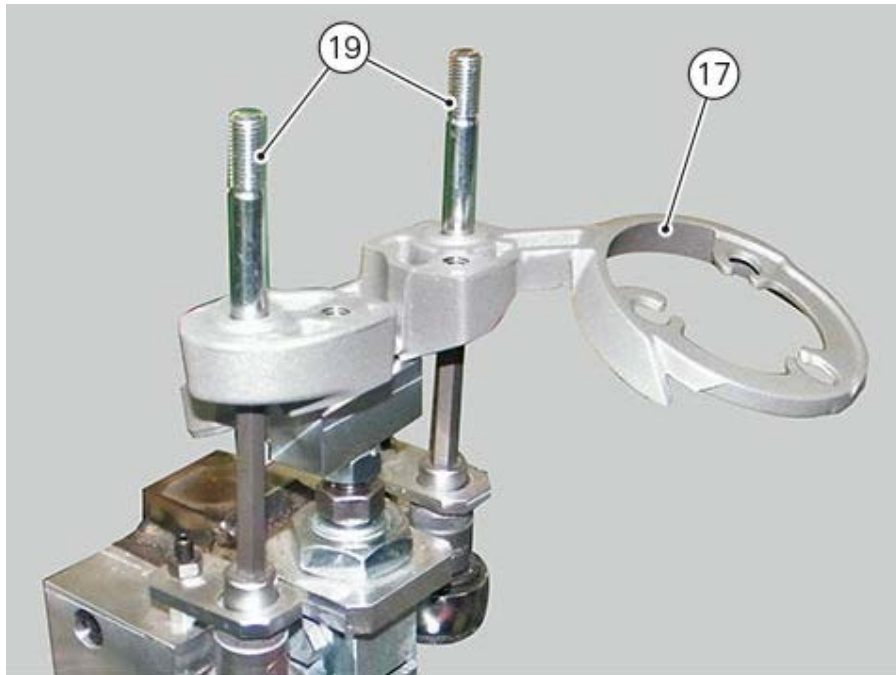

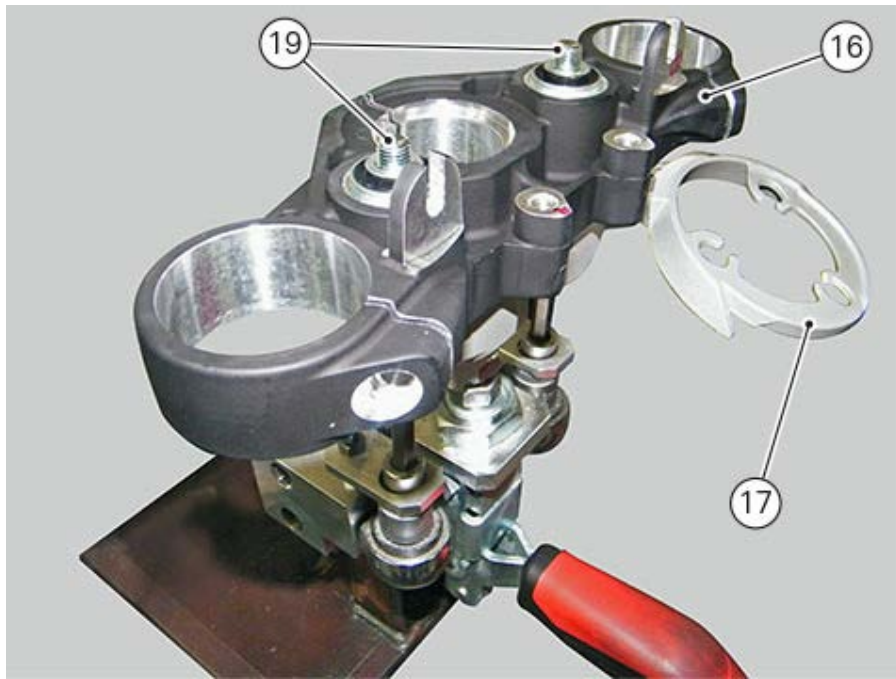

Fit two washers (20) on screws (19) and start two nuts (15).
Screw two nuts (15).

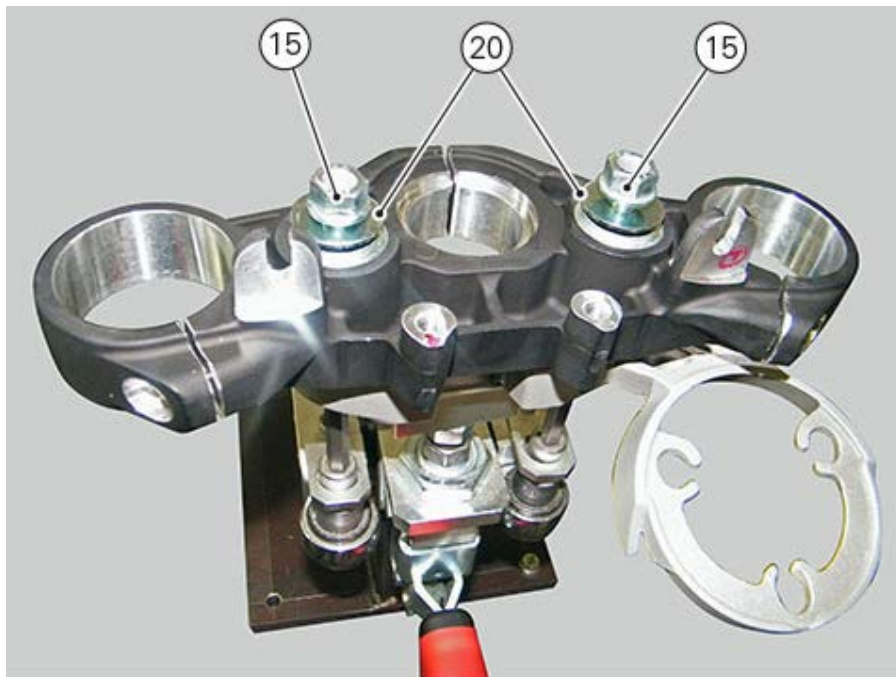

If previously removed, fit rubber blocks (21) in the relevant seats on the lower U-bolt (17).

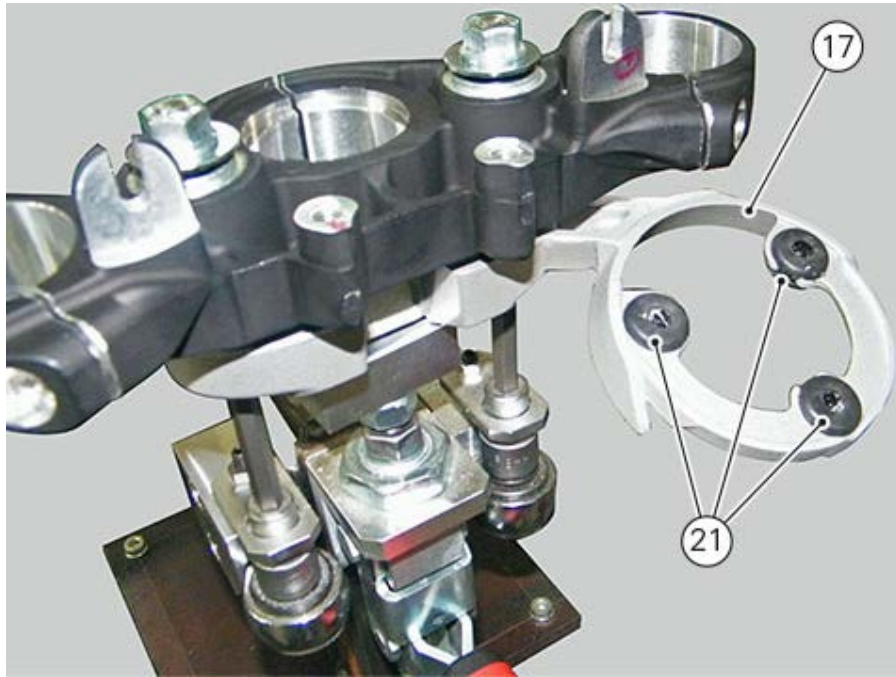

Position handlebar (9) in its seat on the lower U-bolt (17) with the arrows facing the rear side of the vehicle.

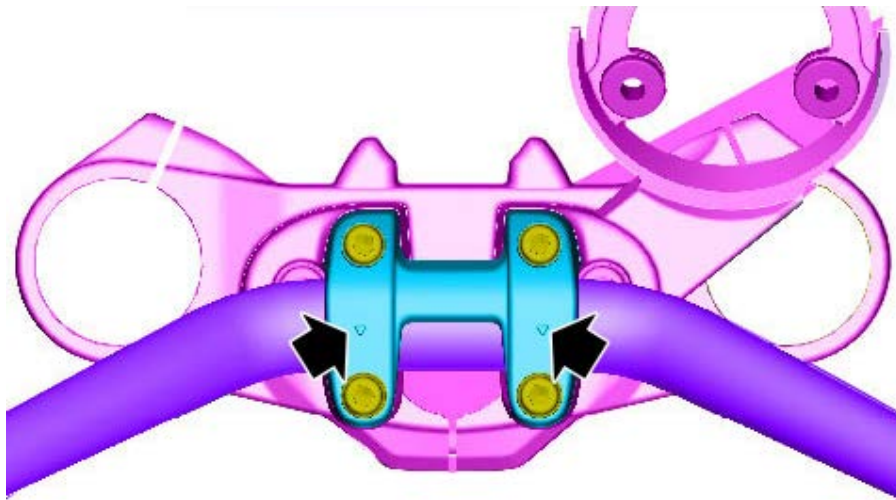

Reference points (A) on handlebar must be at the same distance from U-bolt (8) and flush with the U-bolt surface.



Apply recommended product to screws (7) and tighten to $22 \text{ Nm} \pm 5\%$ in the 1-2-3-4-3 sequence.

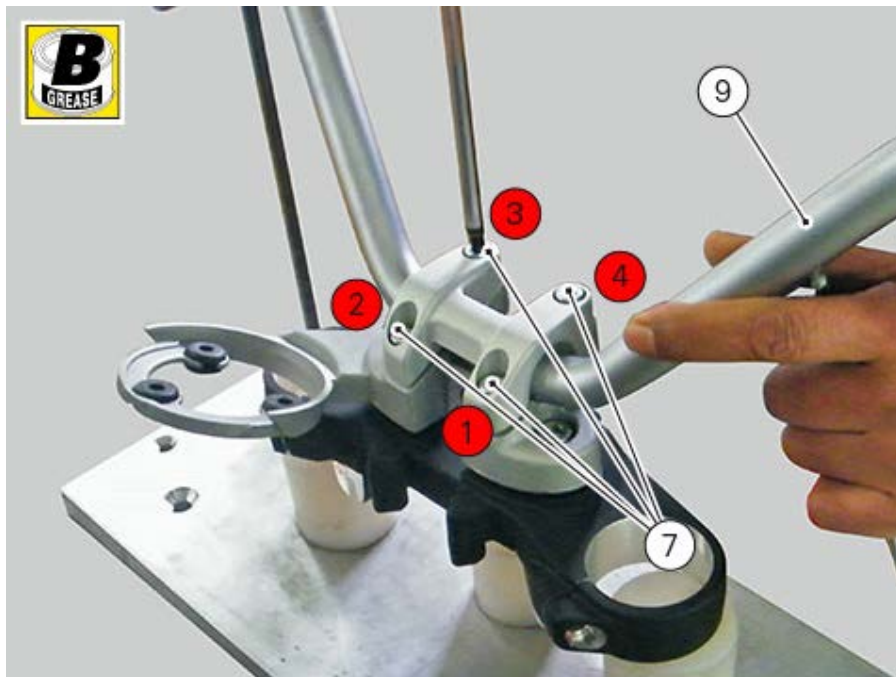

Fit left-hand switch on the handlebar.
Position the switch (5) so that pin (B) engages in hole (C) on the handlebar.

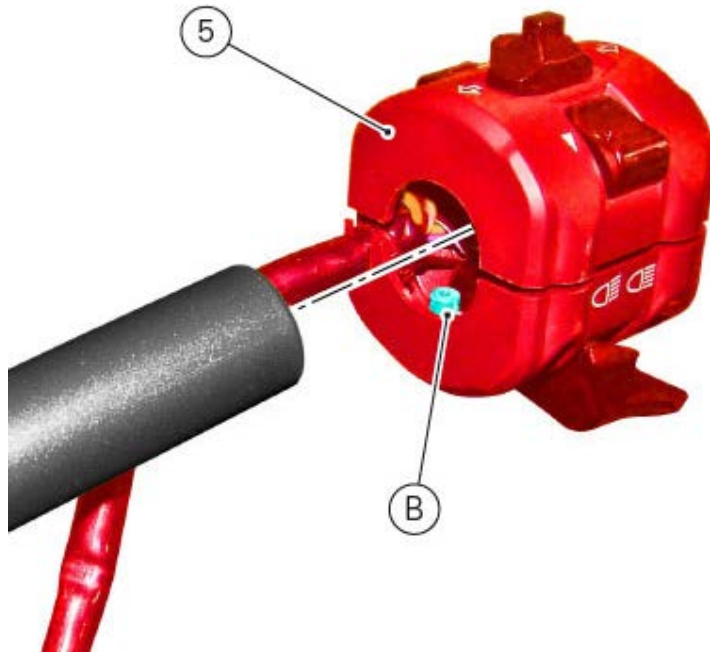

Tighten the screws (4) to a torque of $1.5 \text{ Nm} \pm 10\%$.

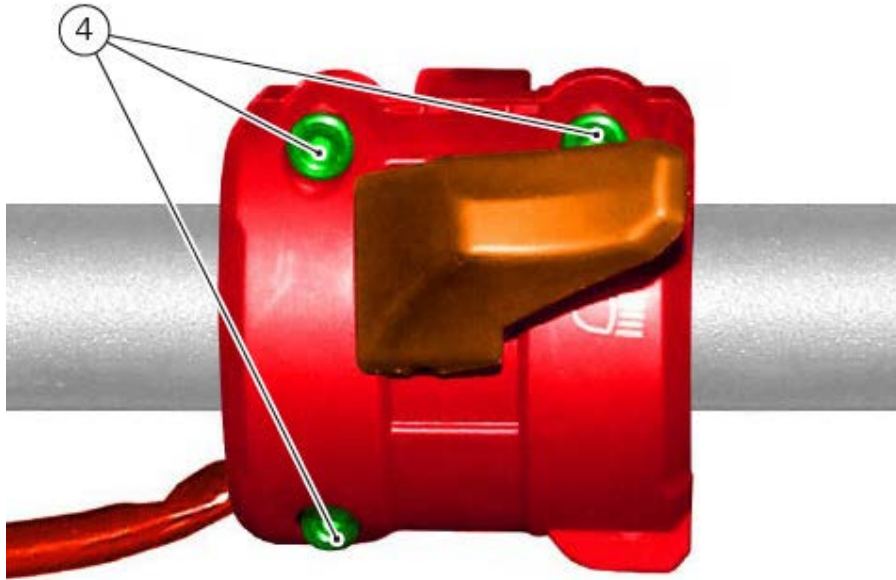

Fit right-hand switch (2) on the handlebar.
Position the switch (2) so that pin (D) engages in hole on the handlebar (E).



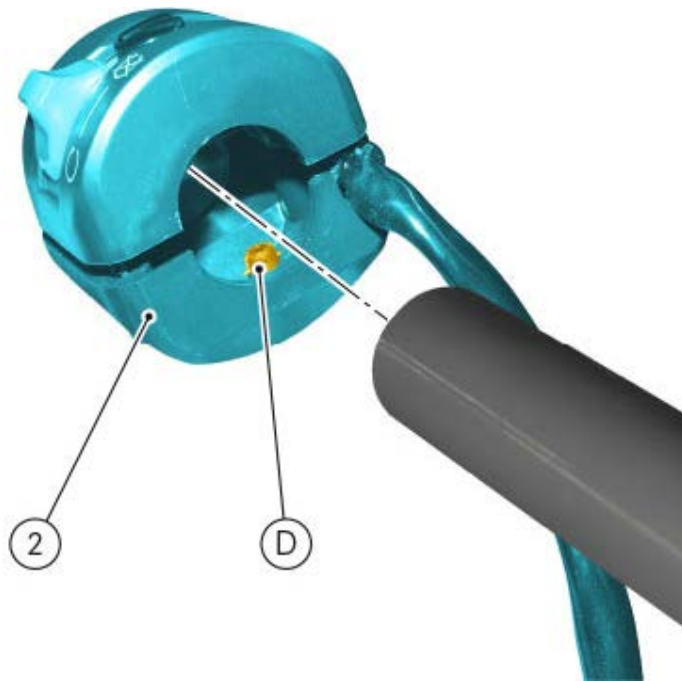

Tighten the screws (1) to a torque of $1.5 \text{ Nm} \pm 10\%$.

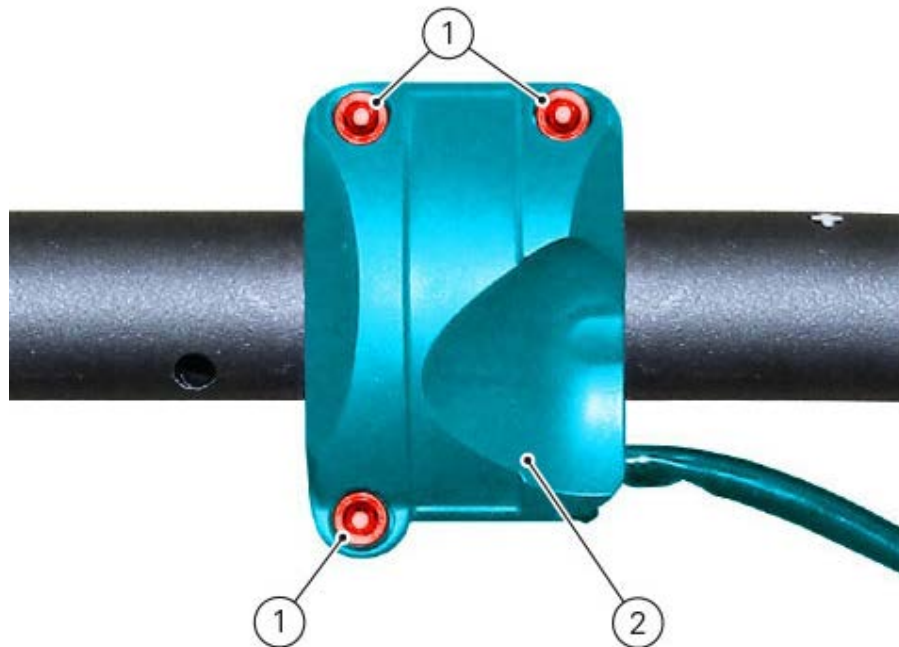

Insert counterweight (B) in the handlebar and fix it with screw (B).
Tighten the screw (B) to a torque of $3.5 \text{ Nm} \pm 10\%$.

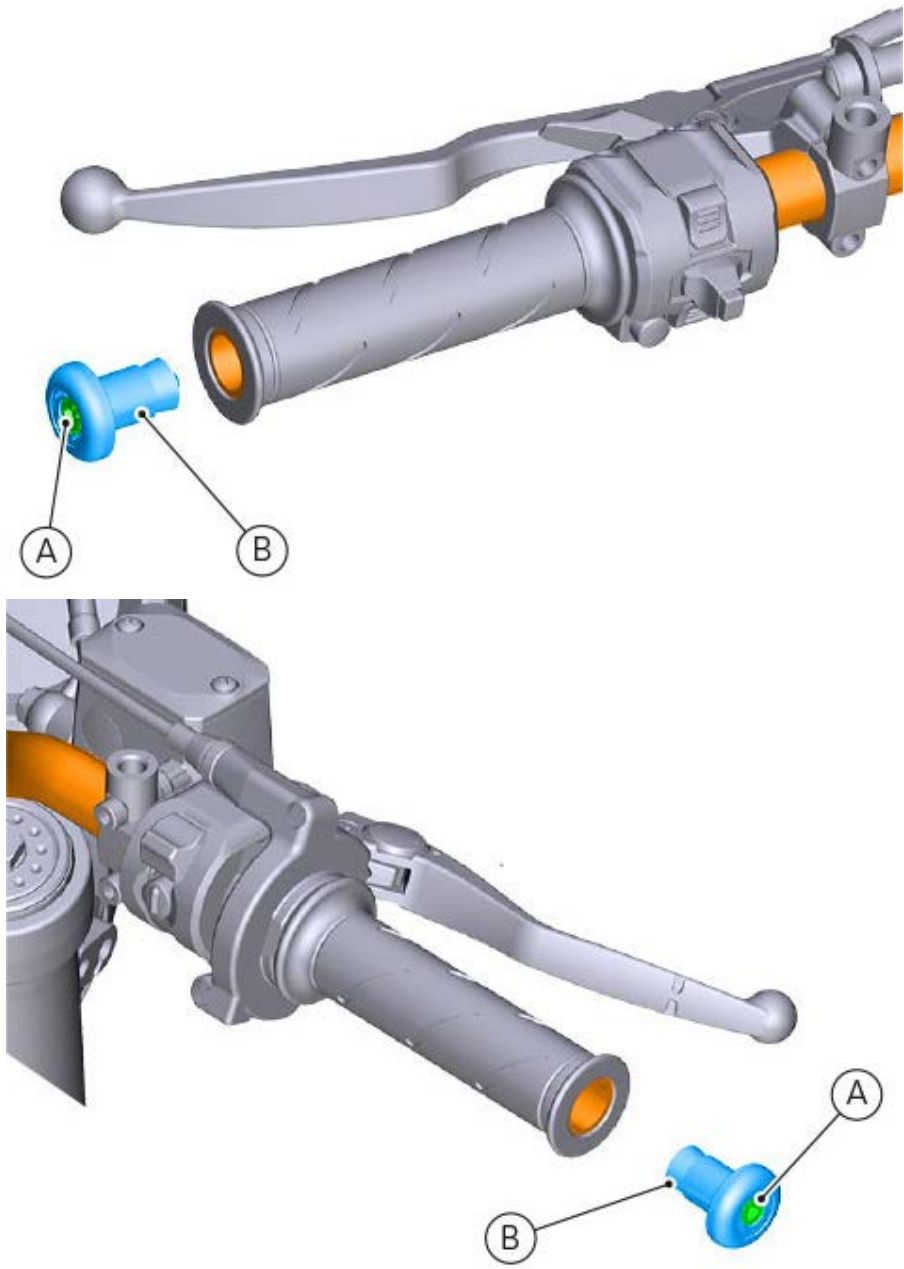

Removing the handlebar

Remove the throttle control ([Removing the throttle control](#)).

Remove the complete front brake control ([Removing the front brake system](#)).

Remove the clutch control ([Removing the clutch assembly](#)).

Handlebar counterweight

Loosen the retaining screw (A) and remove counterweight (B).

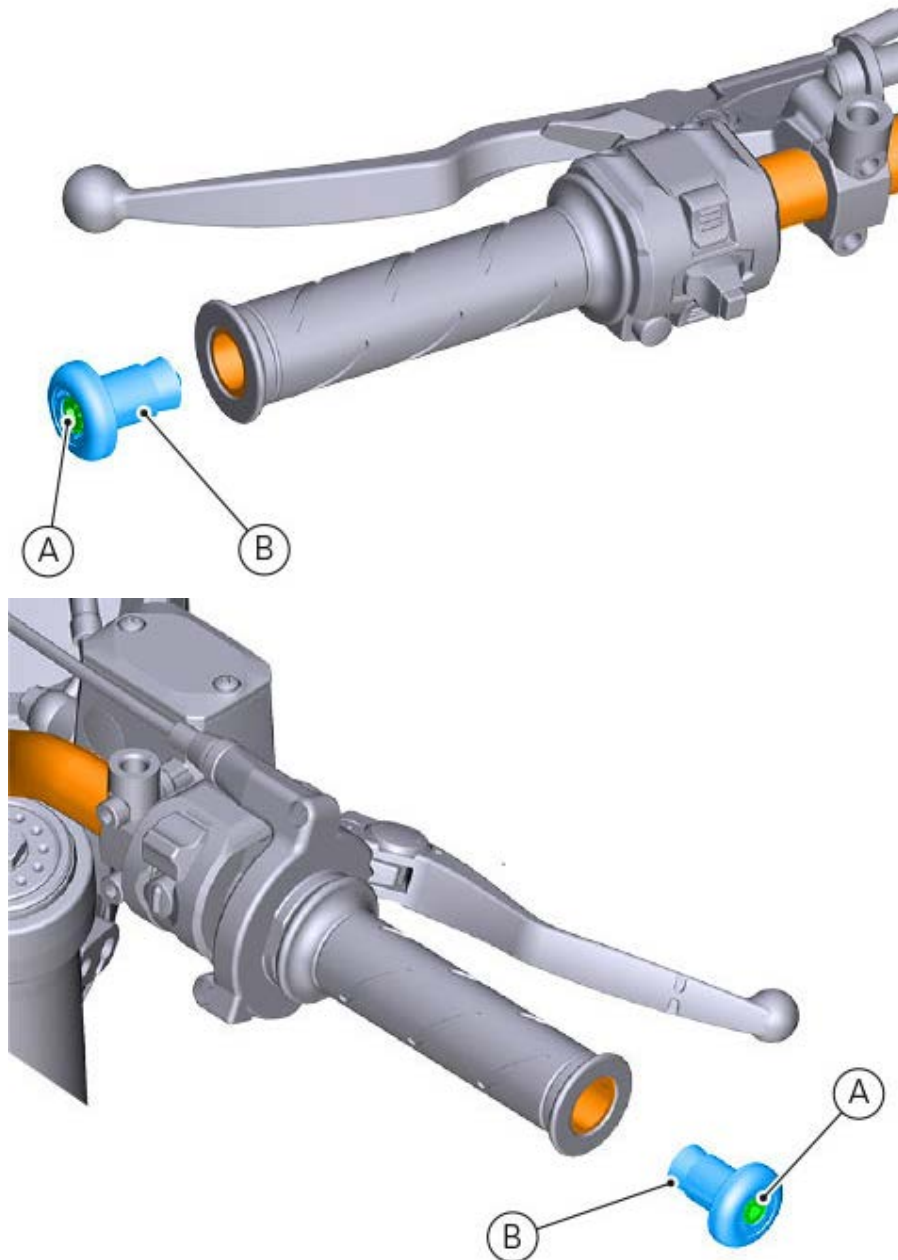

Loosen screws (1) retaining switch (2) and disconnect connector (3).

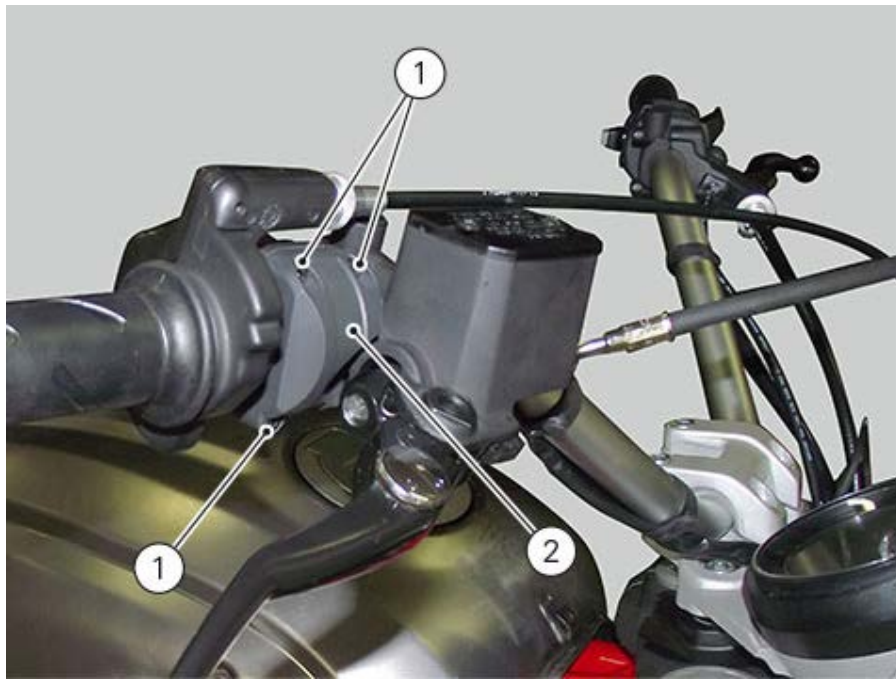

Remove left-hand switch (5), by disconnecting connector (6) and loosening screws (4).

Undo and remove the screws (7).
Remove U-bolt (8) securing the handlebar.
Remove the handlebar (9).

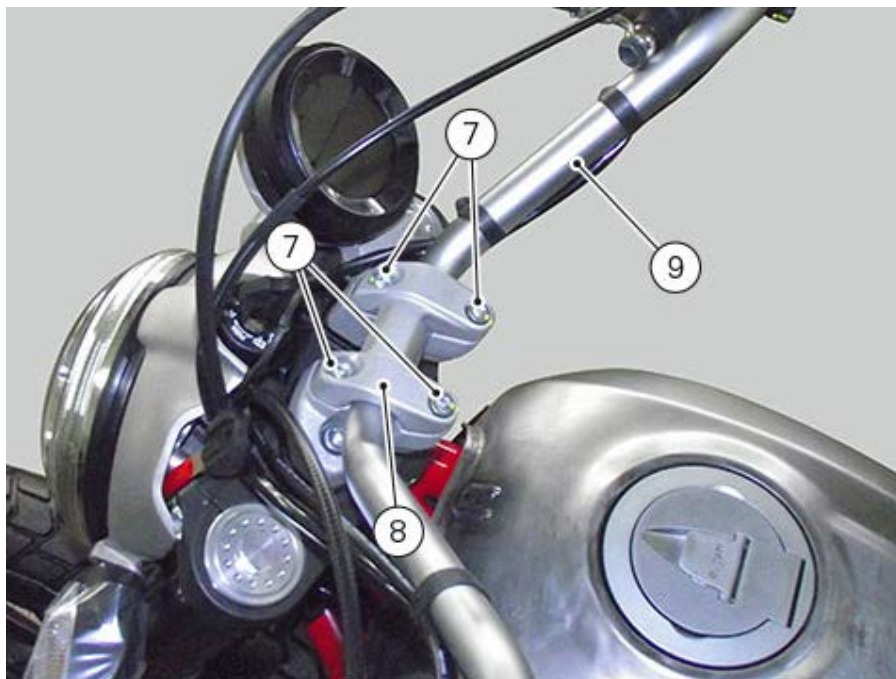

Disconnect instrument panel connector (10).

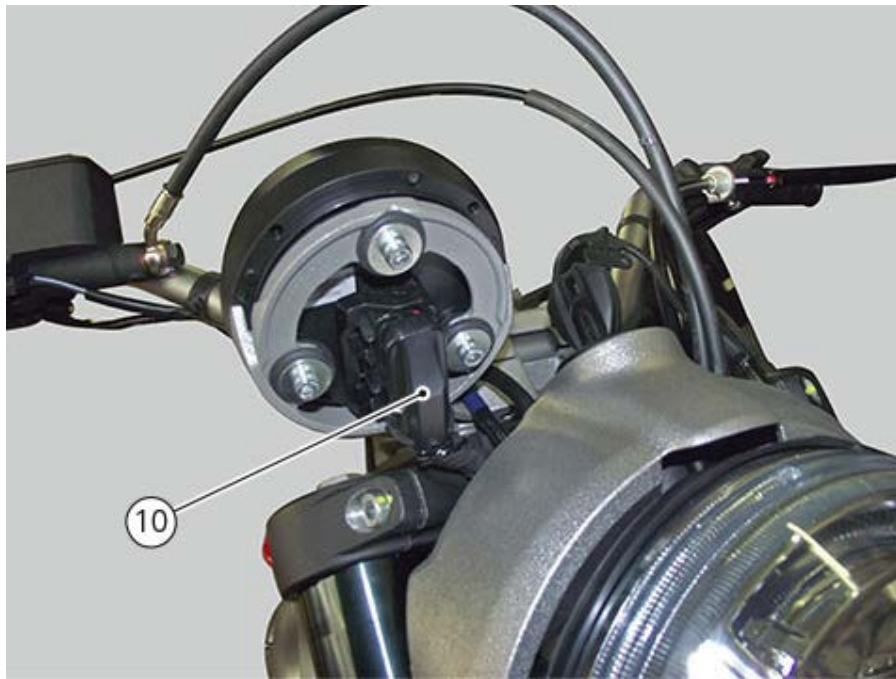

Undo and remove the screws (11) from the steering head.

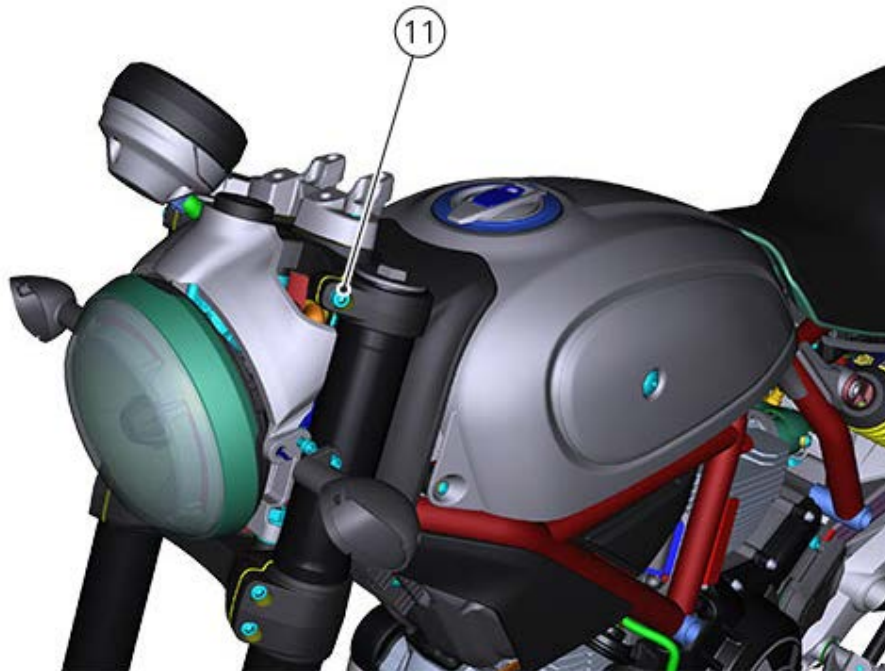

Tighten screw (12) and ring nut (13) and remove the steering head (14).

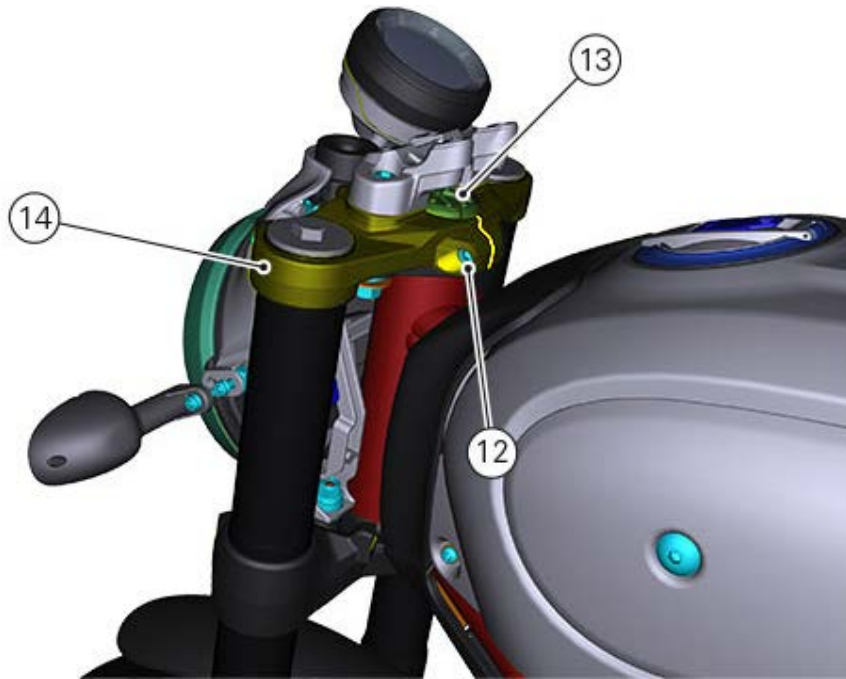

Loosen two nuts (15) and separate the steering head (16) of the lower U-bolt (17).



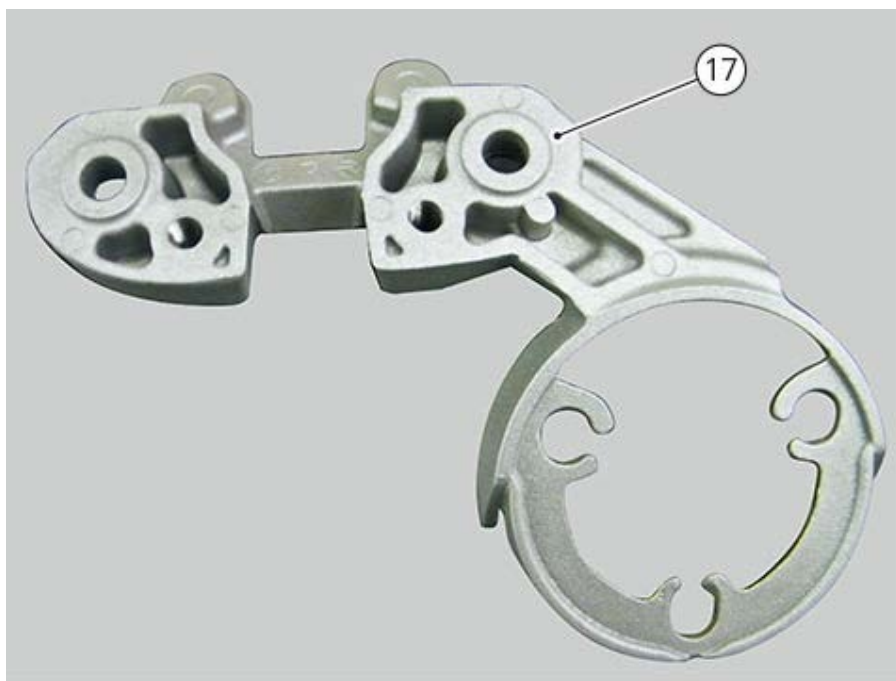
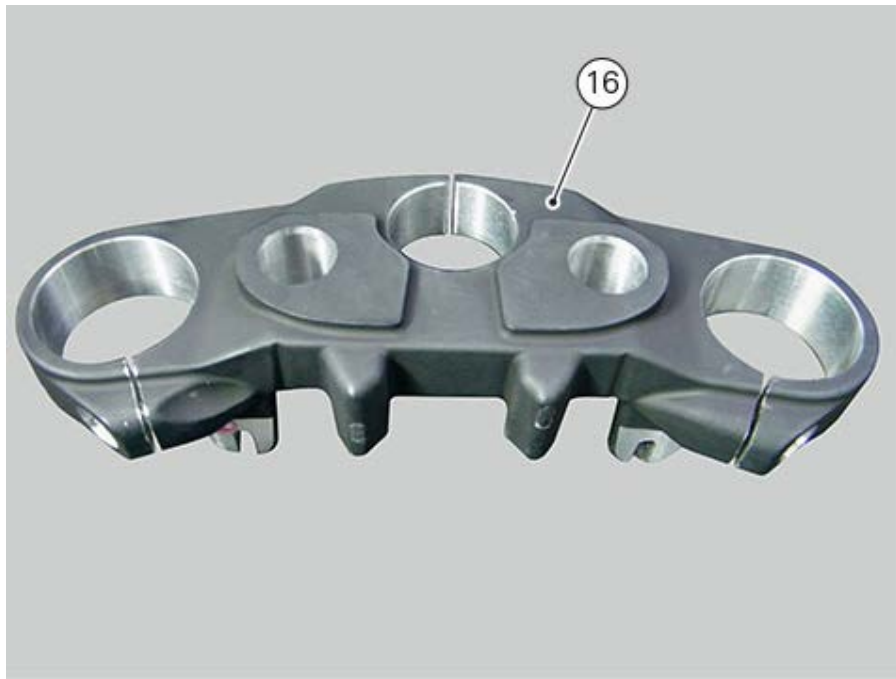

Refitting the clutch assembly

Start the two screws (5) of the clutch control (6).
Tighten the screws (5) to a torque of $10 \text{ Nm} \pm 10\%$.

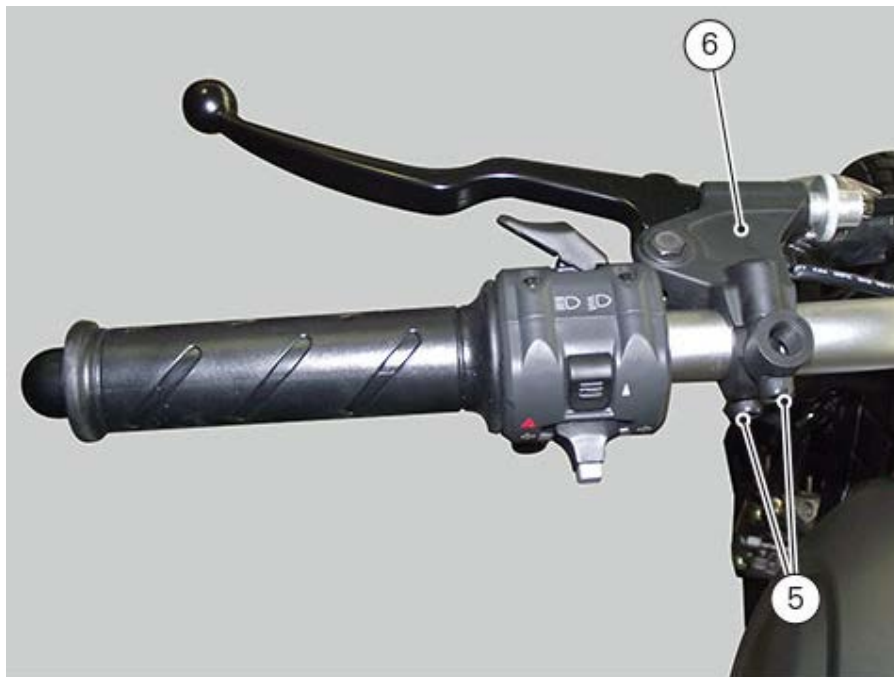

Insert nipple (3) in the clutch layshaft (4).



Tighten screw (1) of the clutch mounting bracket (2).



Removing the clutch assembly

Undo the fixing screw (1) of the clutch bracket (2).



Release nipple (3) from the clutch layshaft (4).



Loosen the two screws (5) of the clutch control (6).

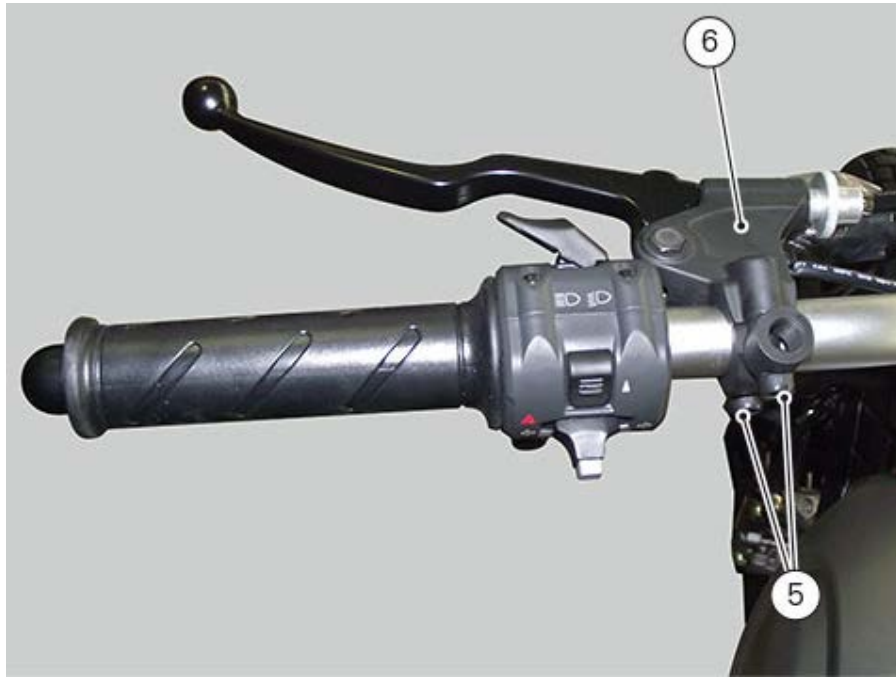

Refitting the ignition switch

Tighten the two retaining screws (2) of the key switch (3).

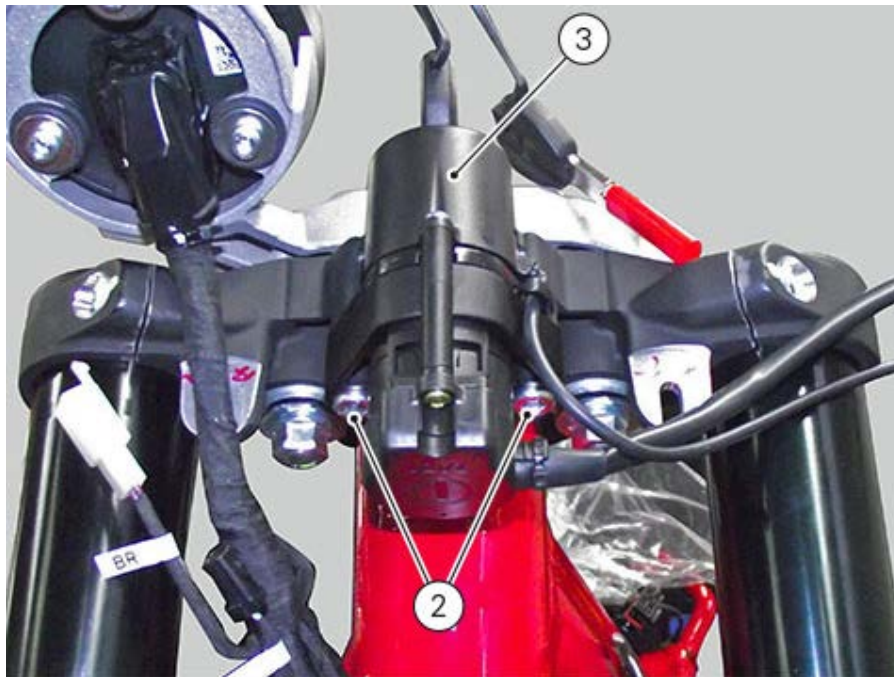

Connect the connector (1).



Refit the headlight.
Refit the tank ([Refitting the fuel tank](#)).

Removing the ignition switch

Remove the fuel tank ([Removing the fuel tank](#)).
Remove the headlight.

Disconnect the connector (1).



Loosen the two retaining screws (2) of the key switch.

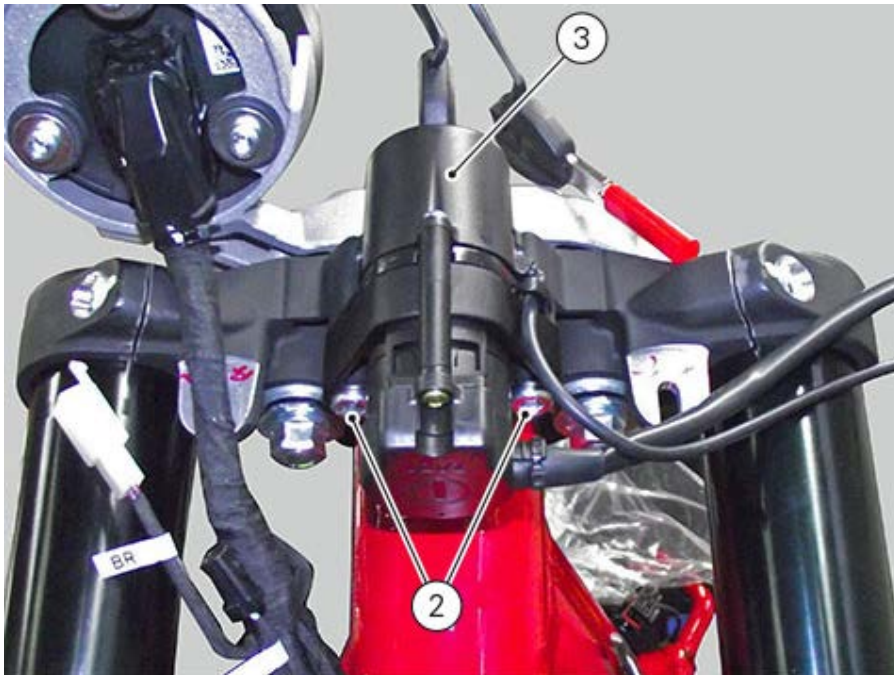

Refitting the gear change control

Grease the two O-rings (10) and the gearchange lever pin (12), except its thread, with indicated product.
Insert pin with O-ring (10) fully home in gearchange lever.
Fit the second O-ring (10) on the shaft.
Start the gearchange lever pin (8), the two O-rings (10) in the LH footpeg holder plate.

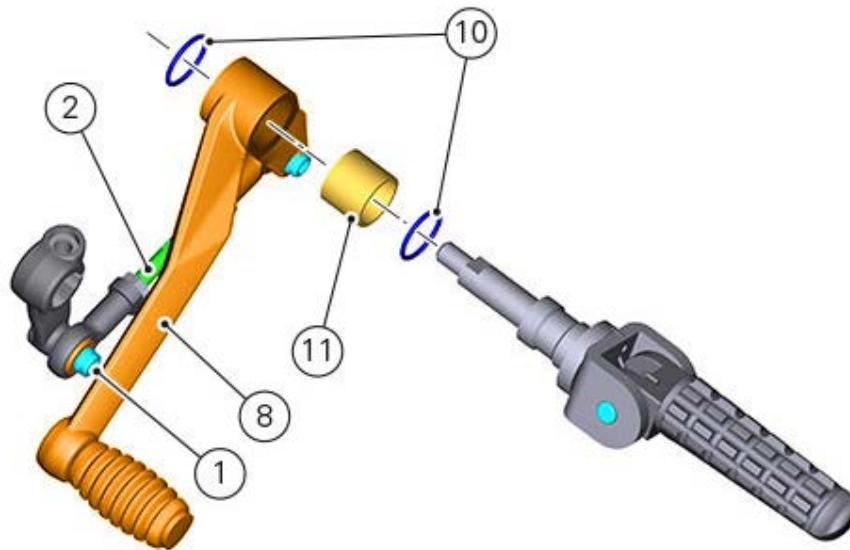

Fit plate (4) fully home in its seat on the footpeg holder.
Start nut (3) and tighten it to a torque of $22 \text{ Nm} \pm 5\%$.

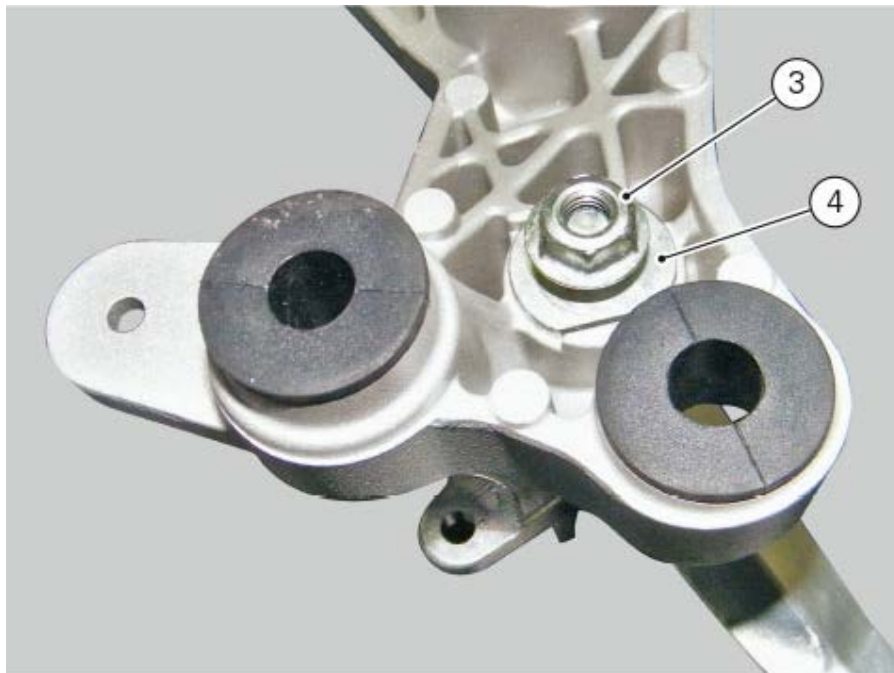

Position rod (2) and fix it to the gearchange lever (8) by means of screw (7).
Tighten the screw (7) to a torque of $10 \text{ Nm} \pm 10\%$.

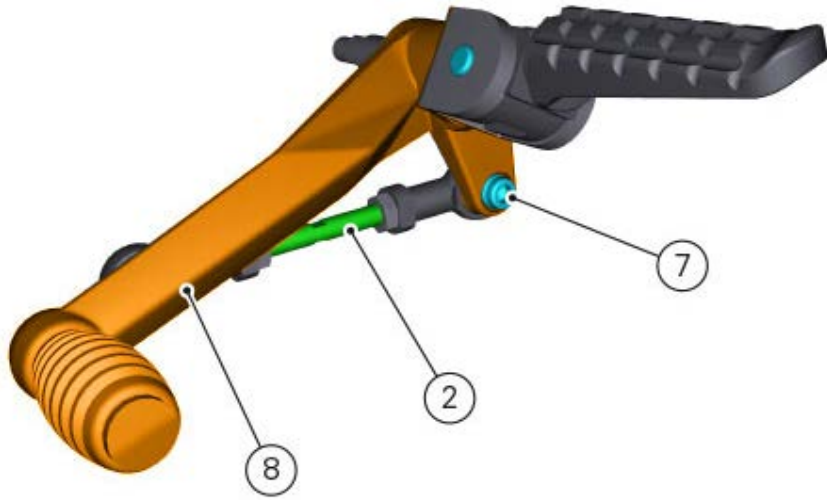

Disassembling the gear change control

Refer to the exploded view for indications on disassembly and replacement of components.

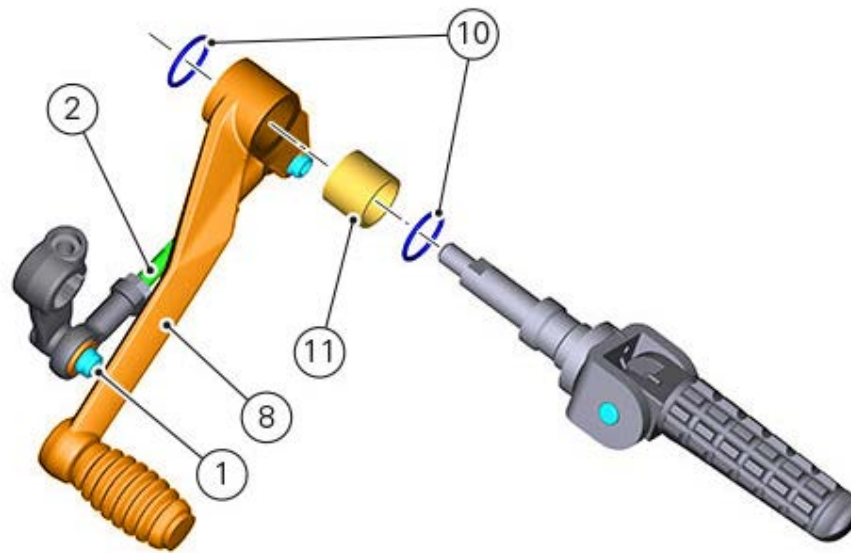

If the bush (11) inside the pedal (8) needs to be replaced, grease the external surface and drive the bush into place using a press. The bush must be seated **2 mm** below the outer face of the pedal.

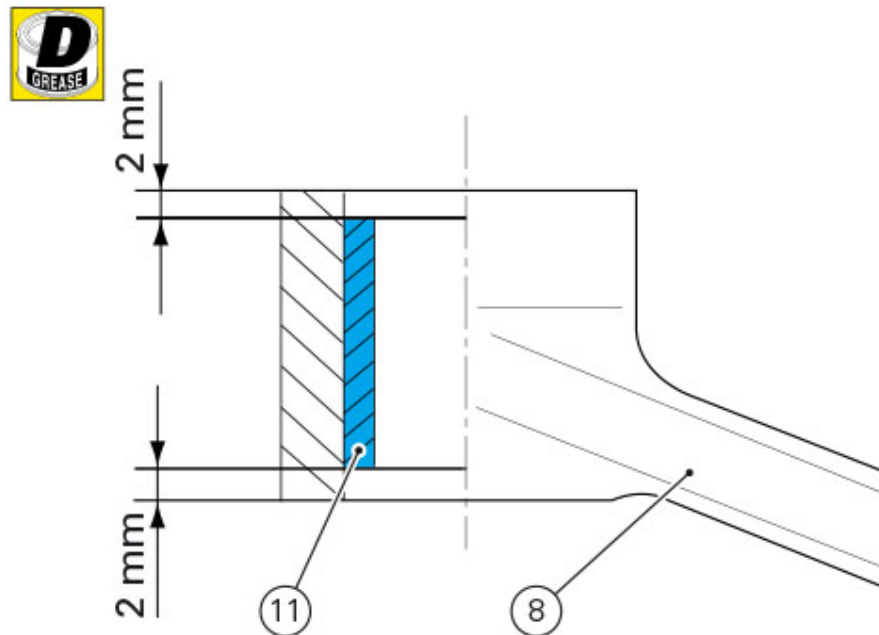

After performing an operation on the gear shift, adjust the gear change pedal position following the instructions detailed in Section "[Adjusting the position of the gear change pedal and rear brake pedal](#)".

Removing the gear change control

Undo the retaining screw (1) of the gearbox rod (2).

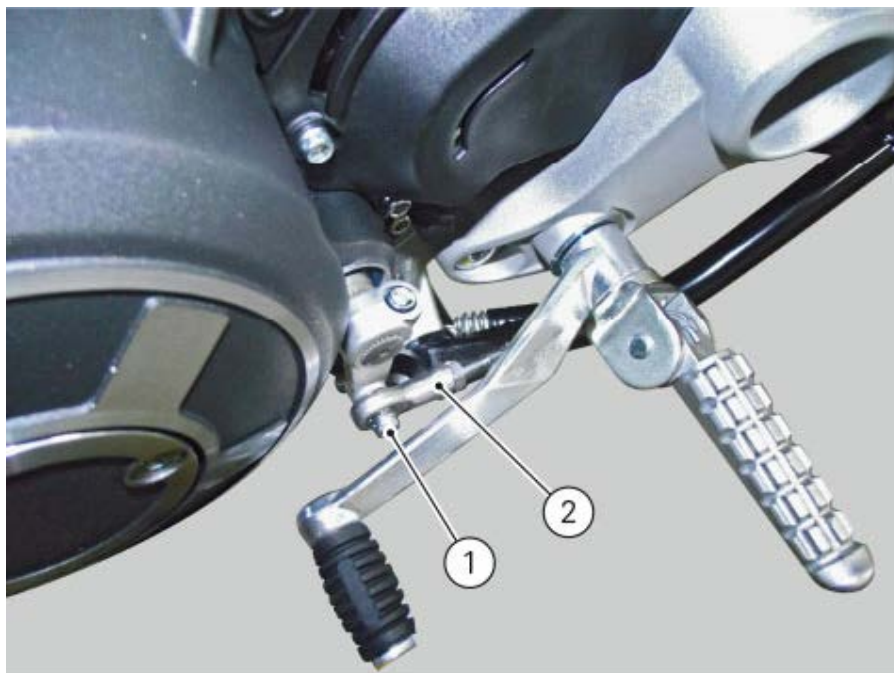
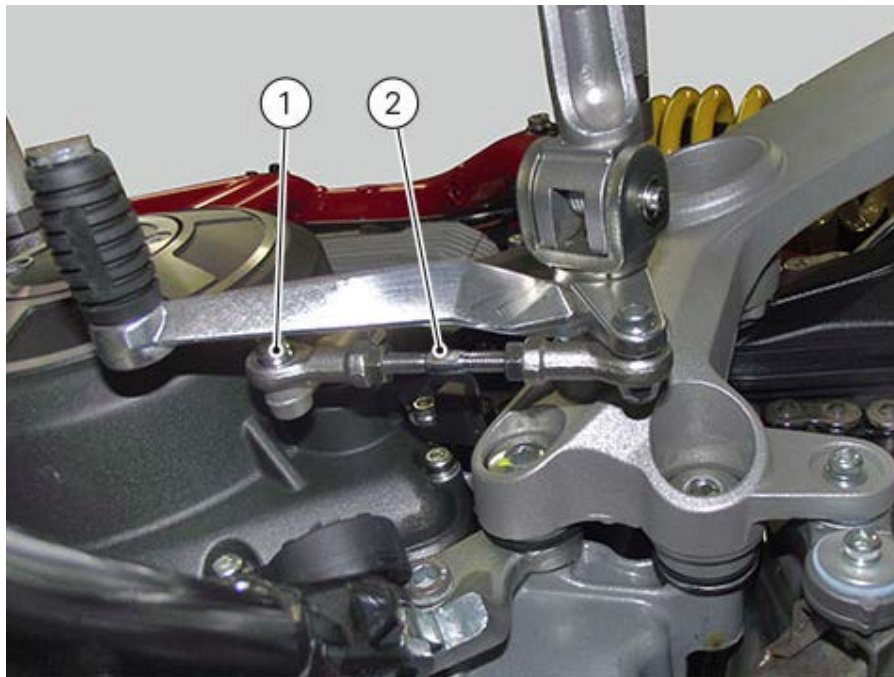

Remove the LH footpeg holder.

Loosen nut (3) and collect plate (4).

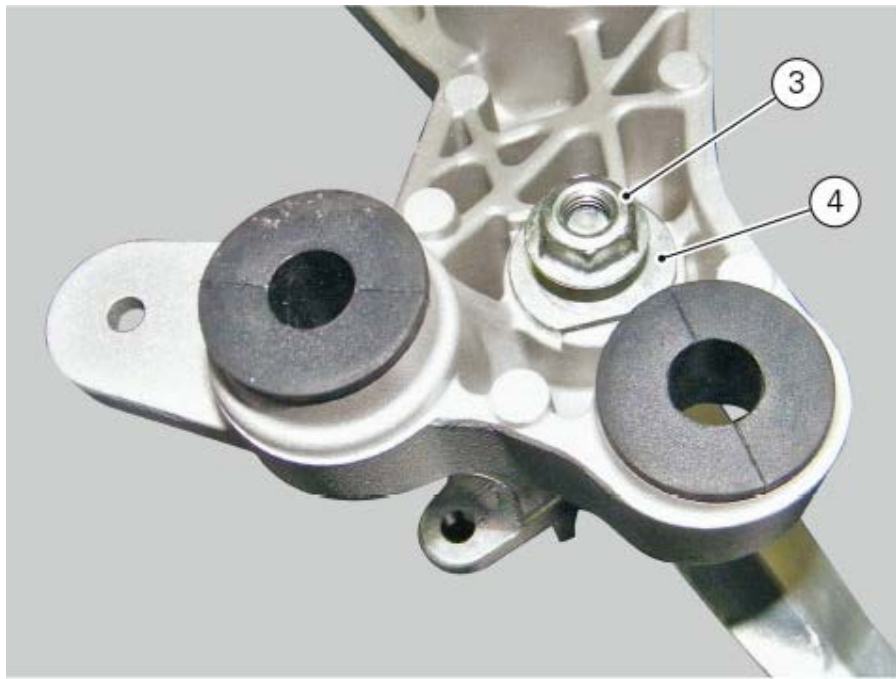

Separate the footpeg/gearchange lever assembly (6) from the footpeg holder (5).



Loosen screw (7) and separate the gearbox rod (2) from the gearbox pedal (8).

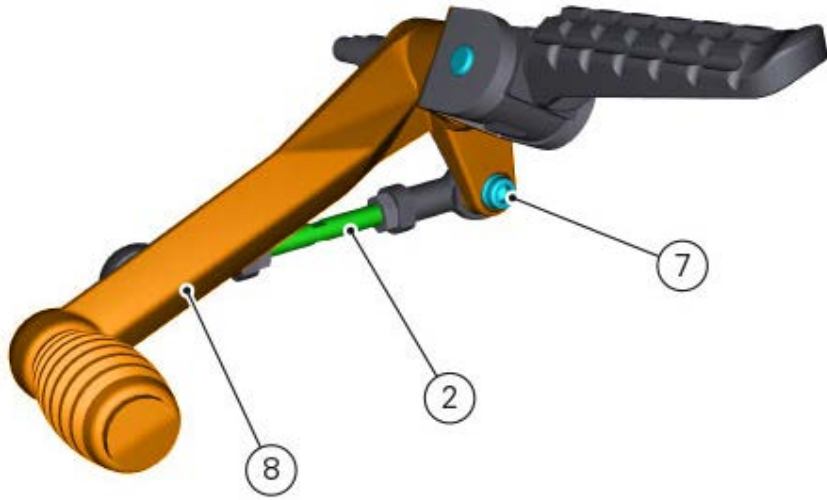

Refitting the front fork

Refit fork (5) on bottom yoke (4) by respecting the indicated value.

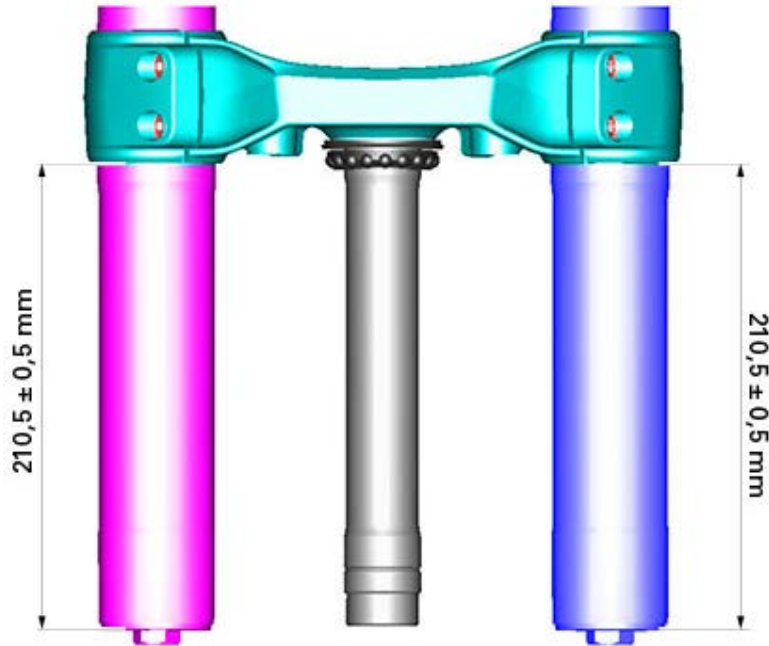

Lubricate screws (1) and (2) with specified product.

Block the leg by tightening screw (1) to a torque of $24 \text{ Nm} \pm 5\%$.

Tighten the screws (2) to a torque of $24 \text{ Nm} \pm 5\%$, following a 1-2-1 sequence.



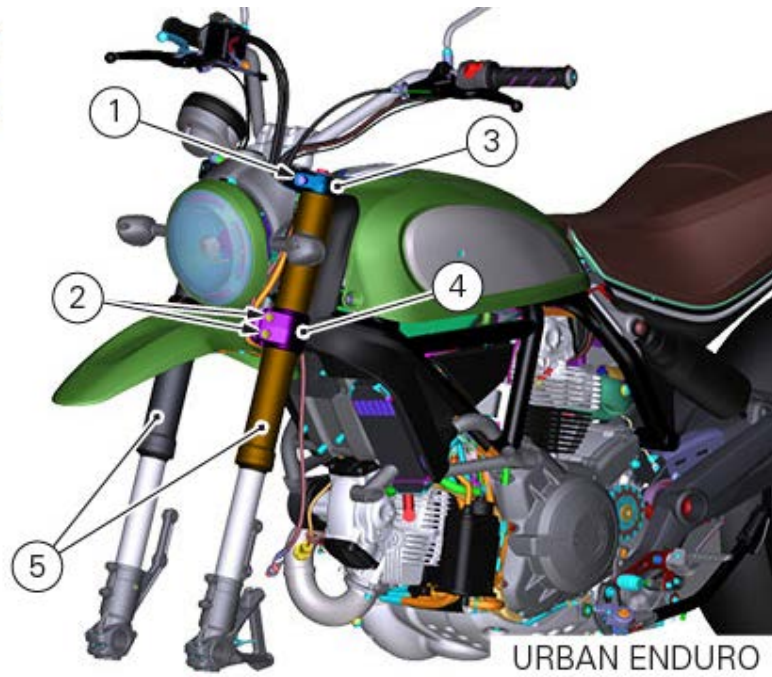

Refit the previously removed components:
Front brake calliper ([Refitting the front brake system](#)).
Front wheel ([Refitting the front wheel](#)).
Front mudguard ([Refitting the front mudguard](#)). (NOT VALID FOR URBAN ENDURO).
Headlight.
Phonic wheel sensor ([Replacing the front phonic wheel](#)).

Fit spacers (C) of screws (B).
Fit leg cover (A) by fixing it with screws (B).
Tighten screws (B) to a torque of $5 \text{ Nm} \pm 10\%$.
The leg cover procedure is the same for all Scrambler customisations.

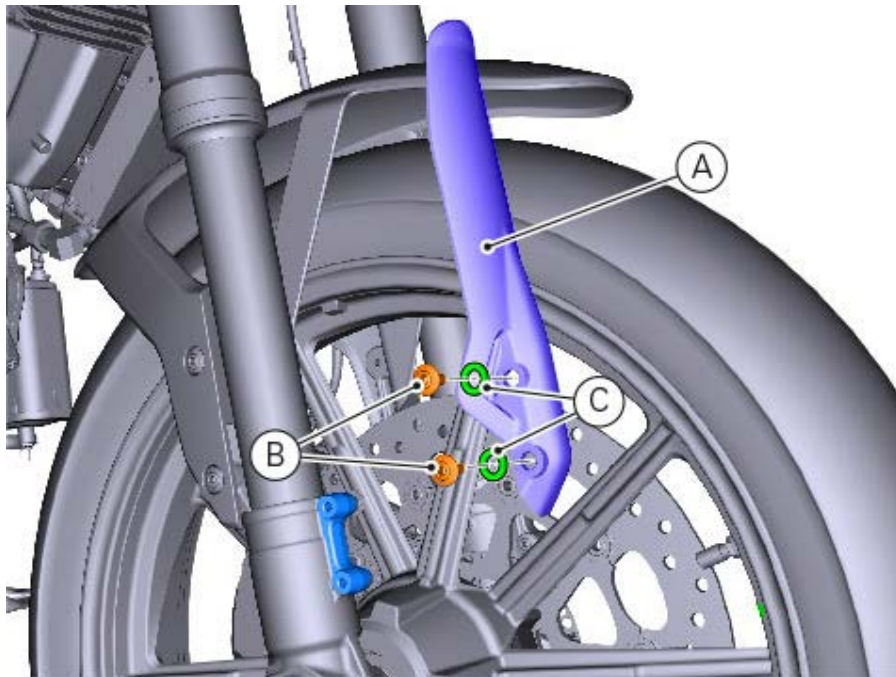

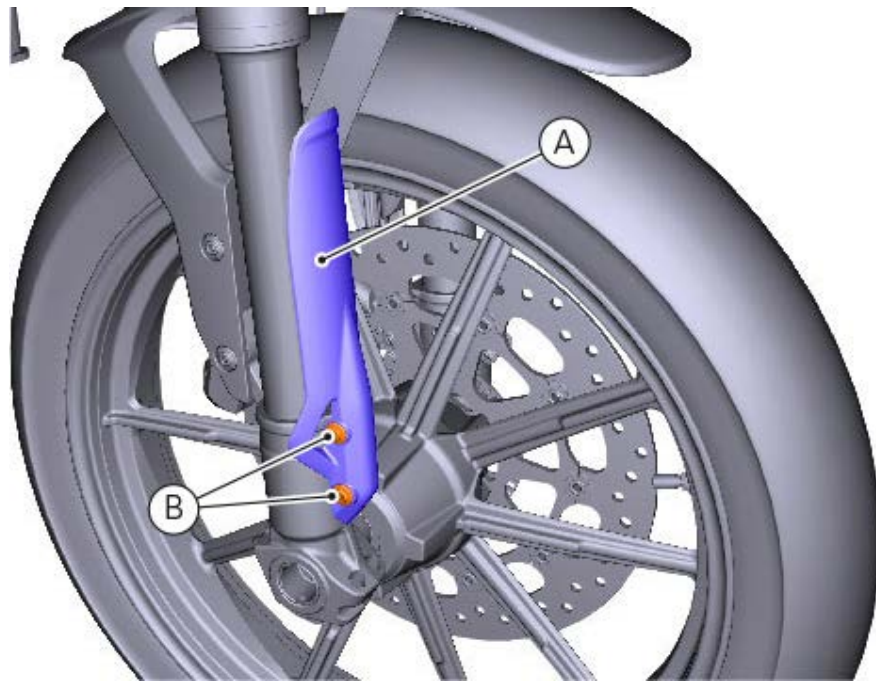

Overhauling the front fork

Remove the front wheel ([Removing the front wheel](#))

Remove the forks ([Removing the front fork](#)).

The two legs are different: the LH one does not have a spring nor the pre-load tube. To remove it, follow the removal procedure of the RH leg.

REMOVING THE RH LEG

Vice the fork (1) and pay attention to protect the sleeve.



Apply some adhesive tape on the hexagon flat to prevent any damage. Slacken the top plug (2).





Take the outer sleeve (1) down.

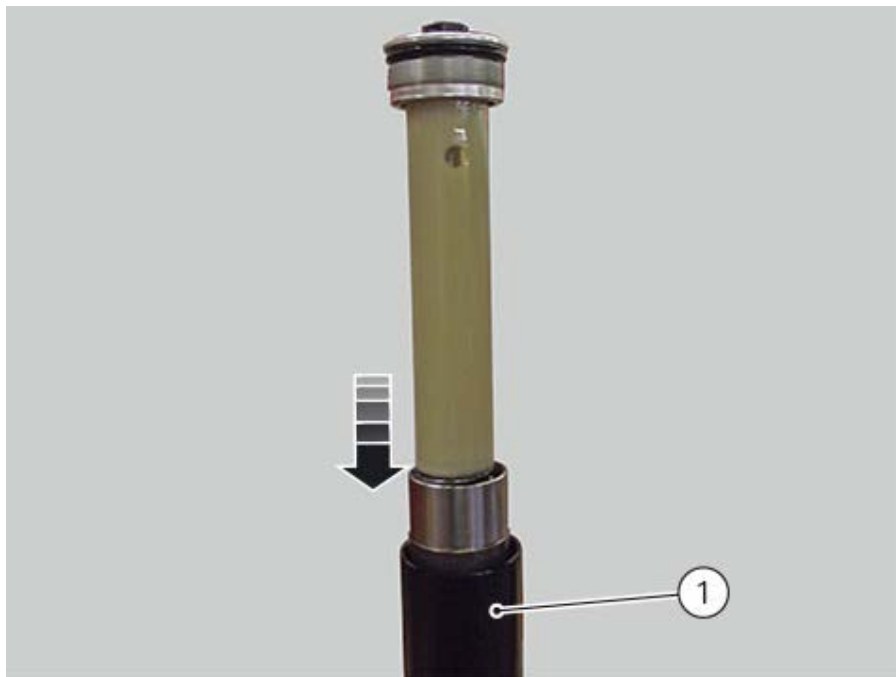

Drain all fluid from the sleeve.
To help draining, move damper rod a few times, then leave sleeve upside-down until fluid has completely drained.



Important

Draining all fluid from the fork is very important. because, due to fork construction and design, it is not possible to measure the air volume from fluid surface to fork edge when filling the fork with fluid.

Set the fork in the vice and clamp the bottom end. Use the suitable protection plates to avoid any damage. Remove the fork plug (2) and detach it from damper rod assembly. Remove pre-load tube (3) and spring (4).

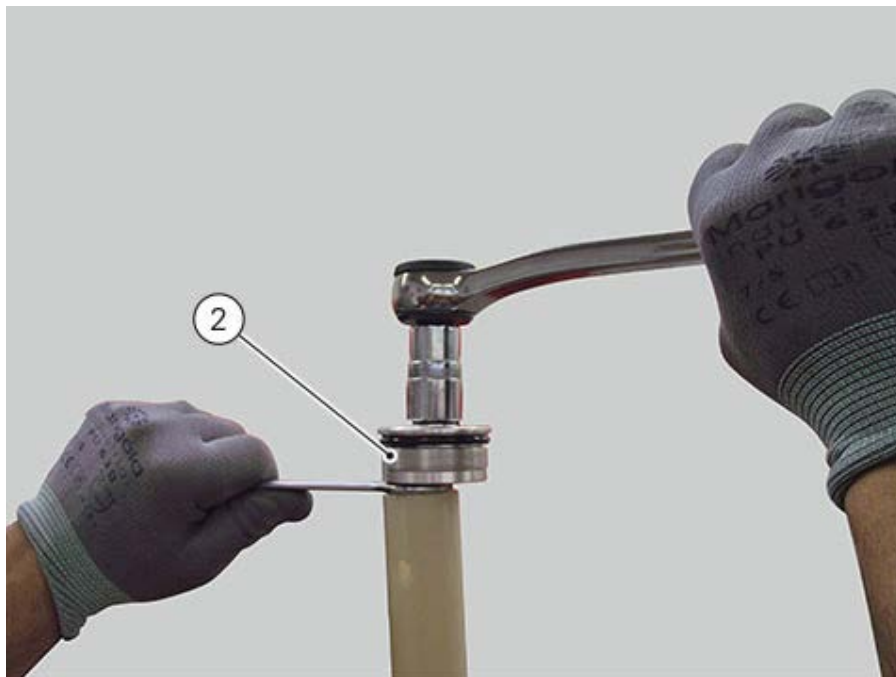

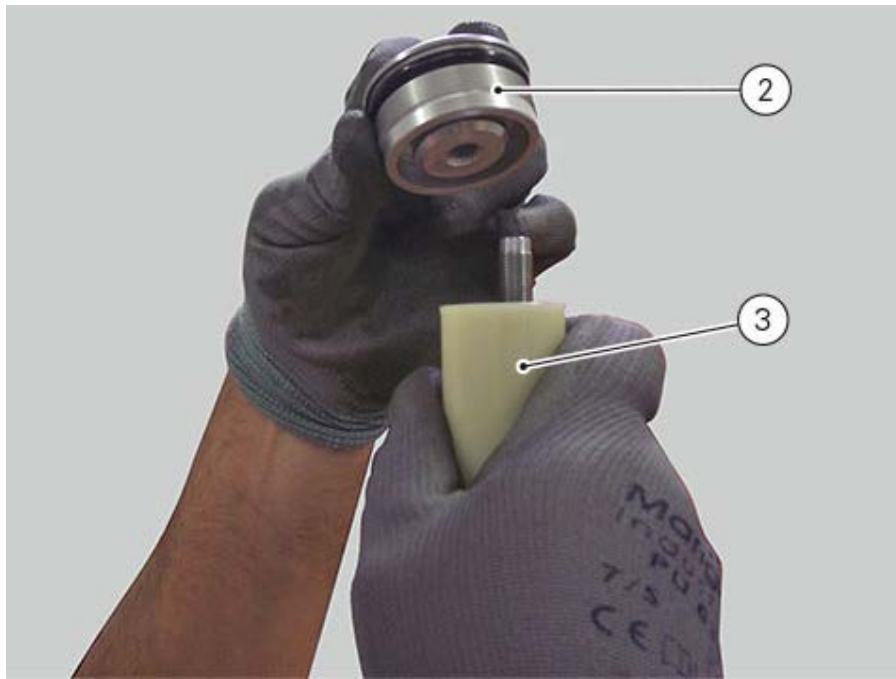

Remove dust seal (5) from outer sleeve (1).

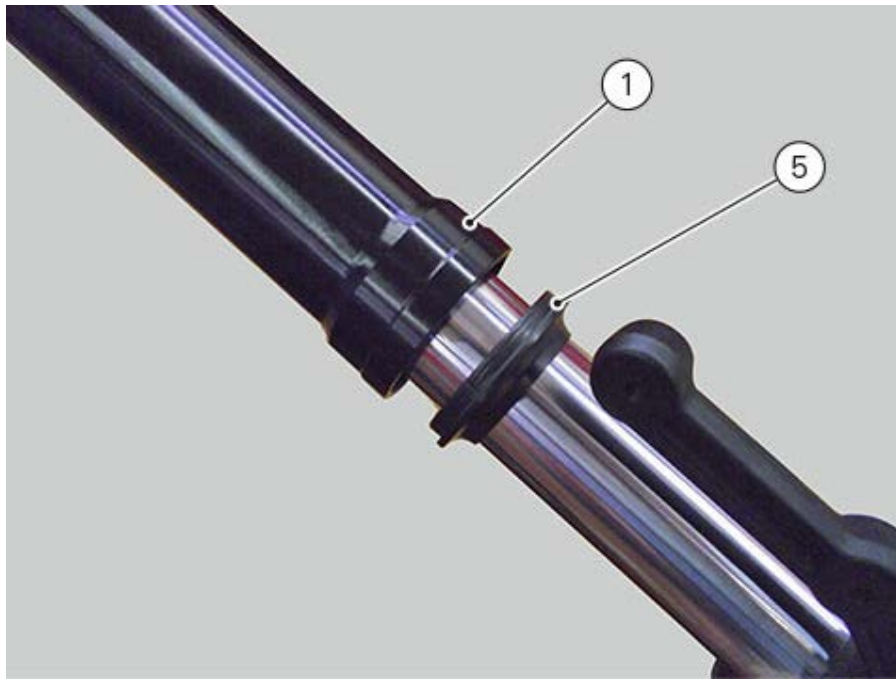

Using suitable tools, remove snap ring (6).

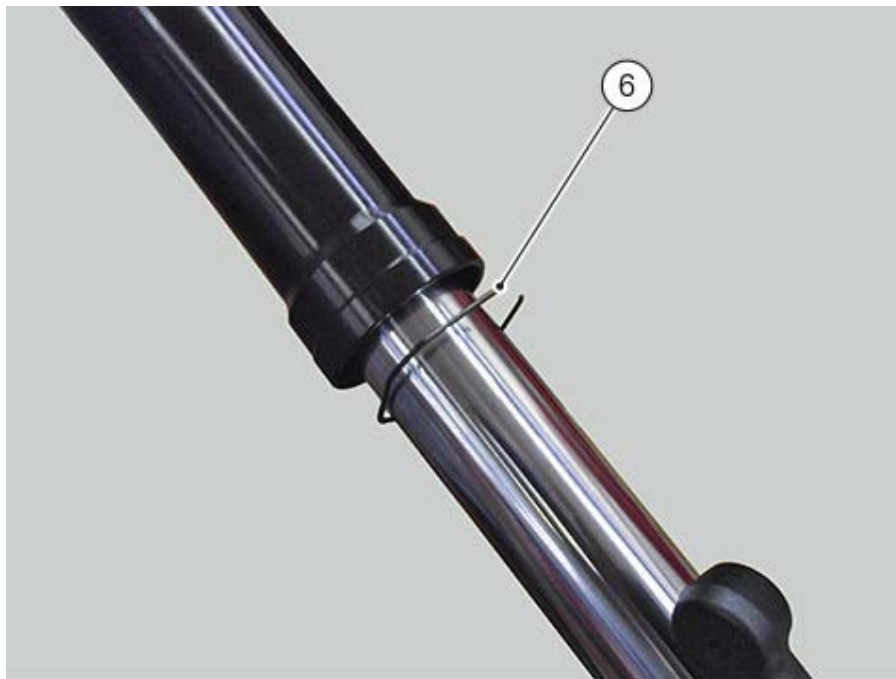

Slide out outer sleeve (1) from fork leg (7) by hitting several times to counter-hold the sliding bushing resistance.

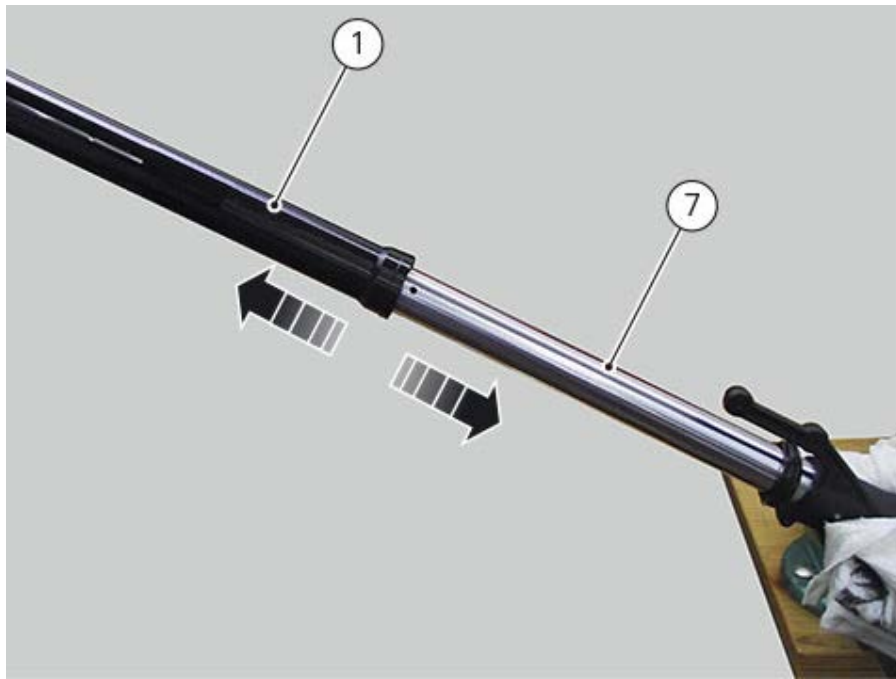

Remove oil seal (8), washer (9) and bushes (10) and (11).

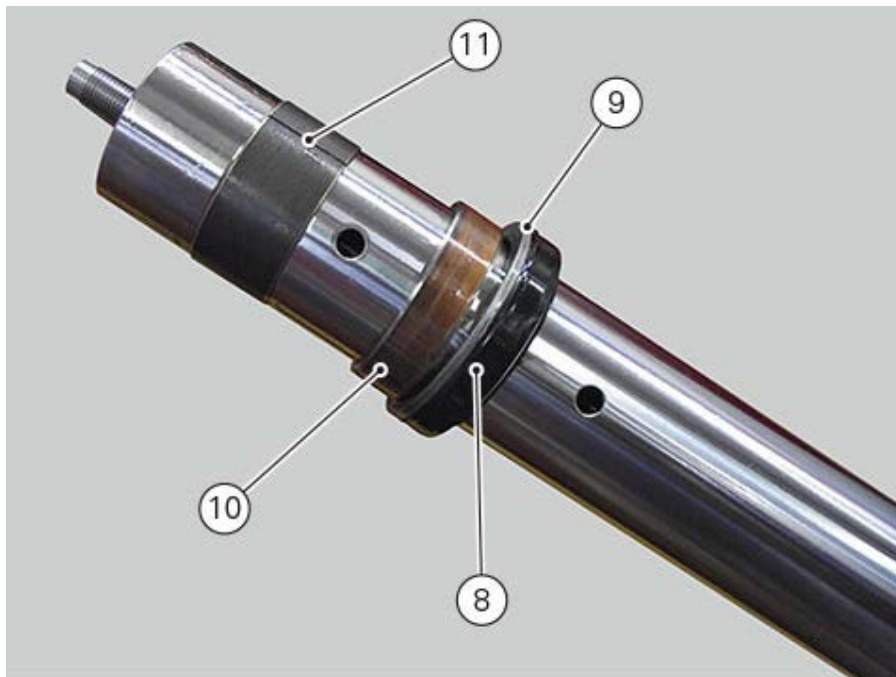

Important

Protect the sleeve with rubber before vicing it to avoid any damage.

REFITTING THE FRONT FORK

Protect bushing seat with some adhesive tape.



Lubricate fork leg with fork oil and install, in this sequence:

- Dust seal (5);
- Snap ring (6);
- Oil seal (8);
- Shim (9);
- Bushing (10).

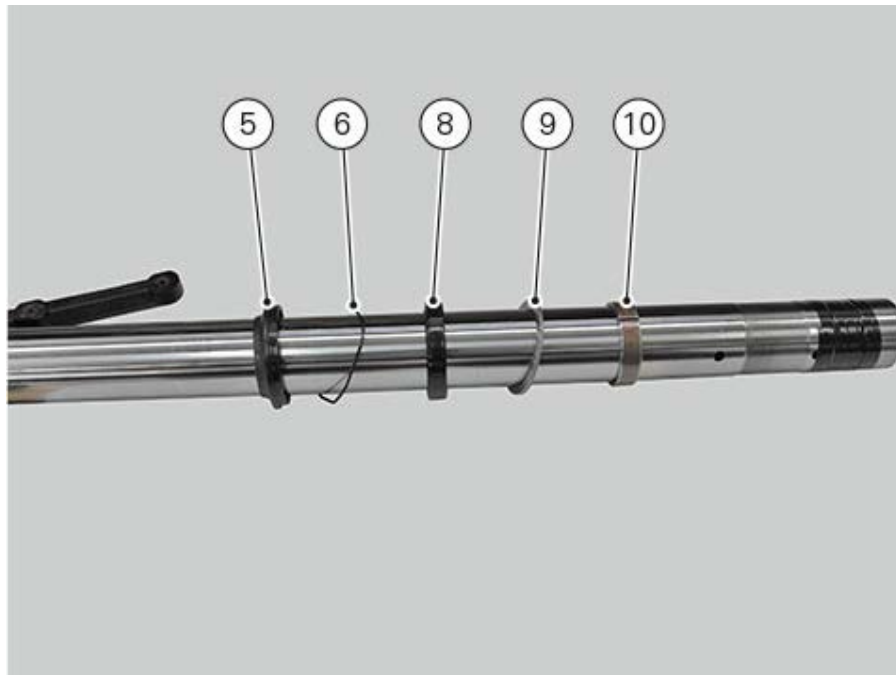

 **Note**

Pay attention to the direction of installation of oil seal, spring must face outward.

Fit leg (7) into sleeve (1).

Install bushing (10) in its housing.

Fit shim (9) on bushing.

Using a suitable drift, push bushing/shim assembly fully home.

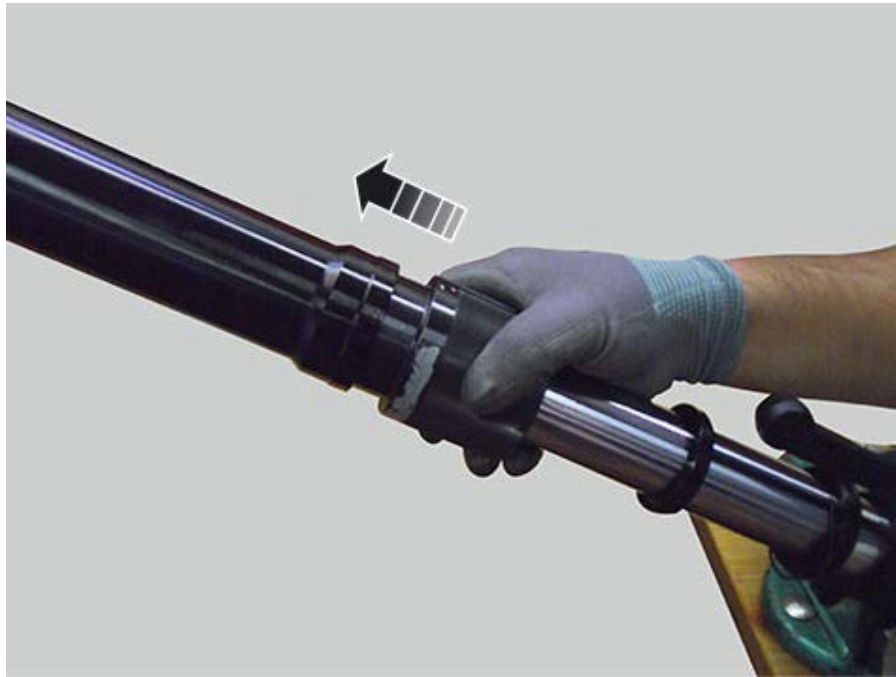

Then, using the same tool, install oil seal (8).
Fit snap ring (6) and dust seal (5).
Remove the adhesive tape previously applied.
Fit the sliding bushing (11) in its housing.



Fit tool (X) part no. **88713.0950**.
Fill in.

Quantity of fluid for the RH leg: 427 cc.
Quantity of fluid for the LH leg: 298 cc.

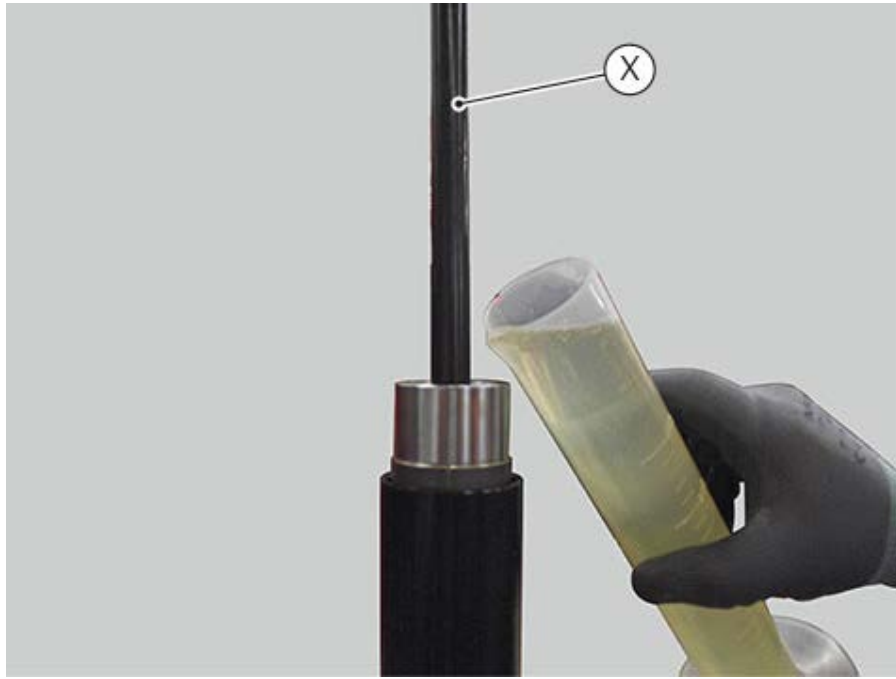

Activate the damper rod a few times.
Fit spring (4).





Important

The spring must be oriented and positioned with the side featuring the smaller diameter against the preload tube.

Insert the preload tube (3).

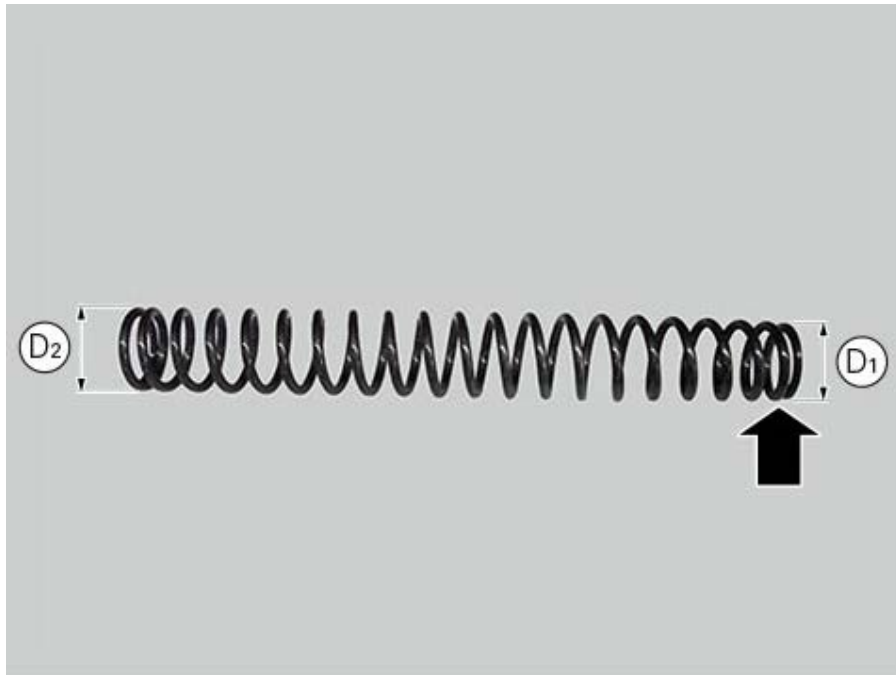



Bring plug (1) fully home on lock nut (12).
Tighten plug (2) on lock nut (12).

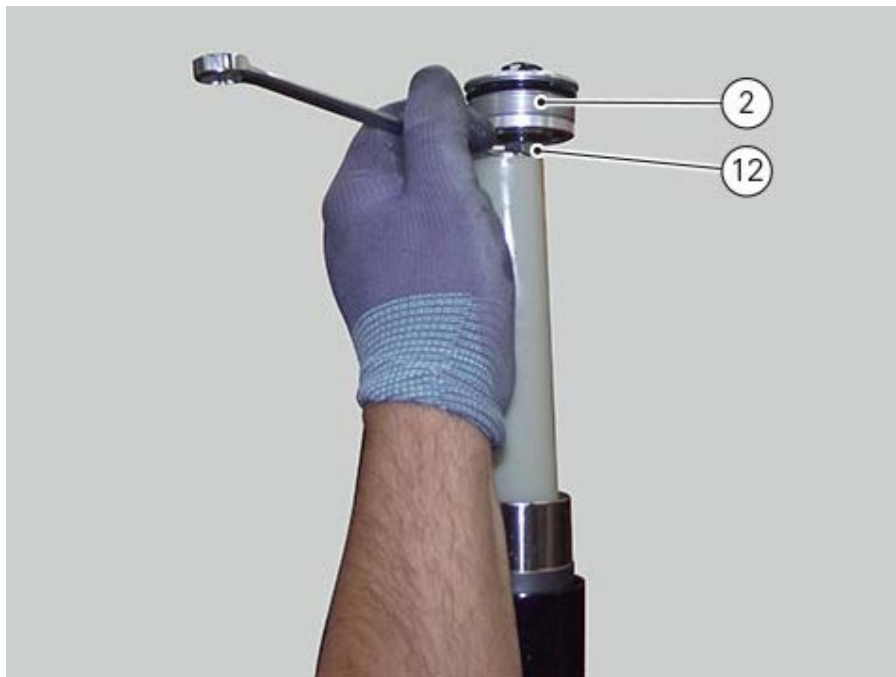

Tighten plug (1) on the fork sleeve.

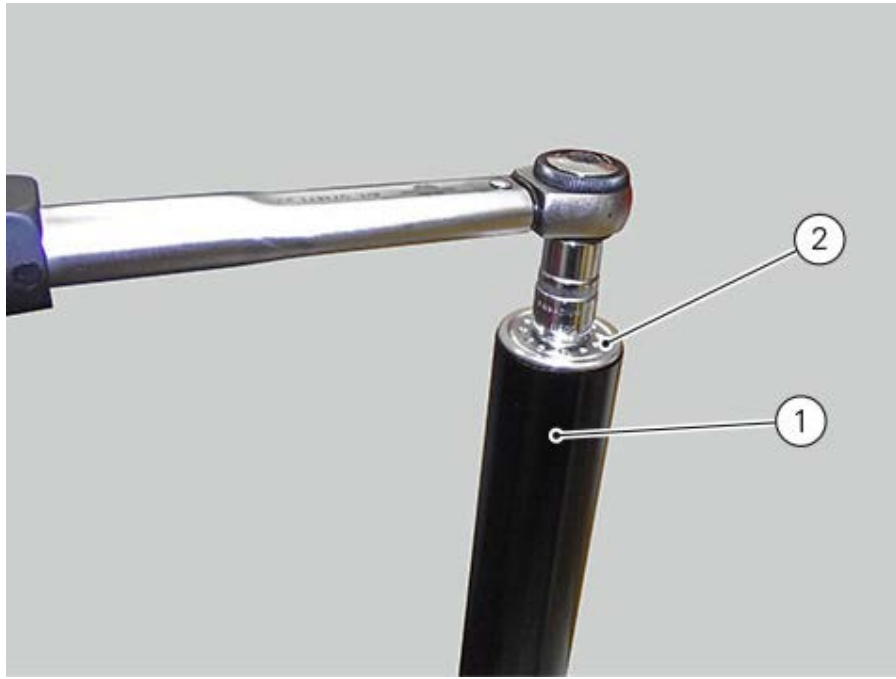

Removing the front fork

Support the front side of the vehicle in a suitable way.

Before removing the component, it is first necessary to remove the following parts:

- Front brake calliper;
- Front mudguard ([Removing the front mudguard](#)); (NOT VALID FOR URBAN ENDURO)
- Front wheel ([Removing the front wheel](#));
- Headlight;
- Phonic wheel sensor ([Removing the brake disc](#)).

The procedure below refers to one fork but it applies to both forks.

Remove leg cover (A) by loosening screws (B) and recovering spacers (C).

The leg cover procedure is the same for all Scrambler customisations.

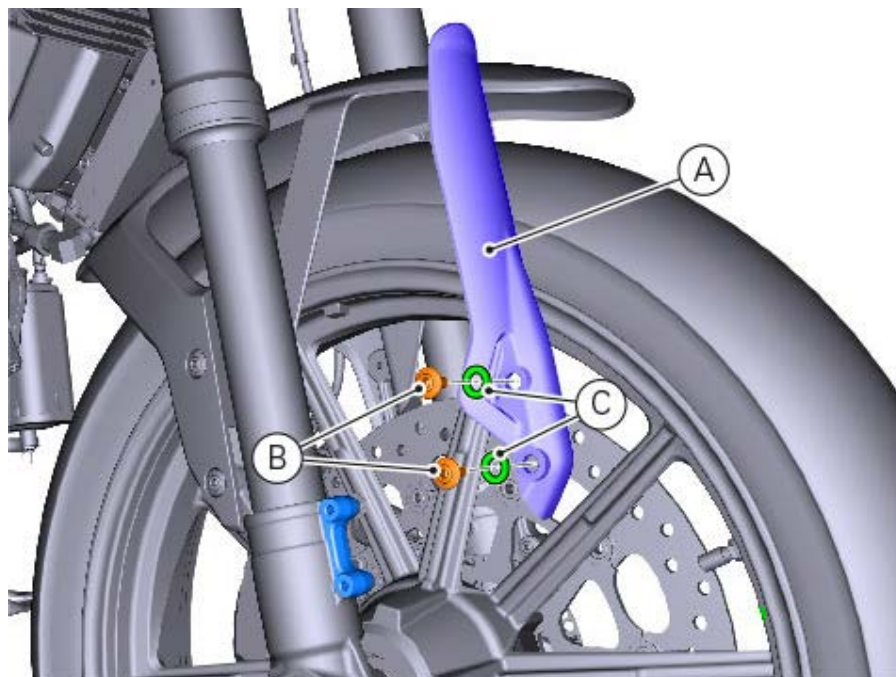
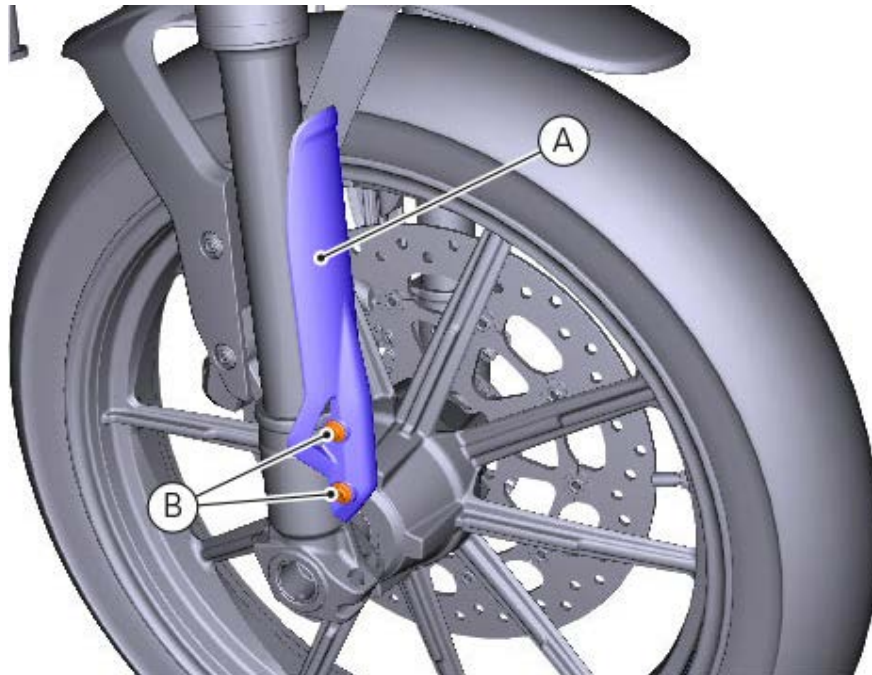

Loosen screw (1) securing the fork sleeve to the steering head (3).

Loosen screw (2) securing the fork sleeve to the bottom yoke (4).
Slide the fork downwards.

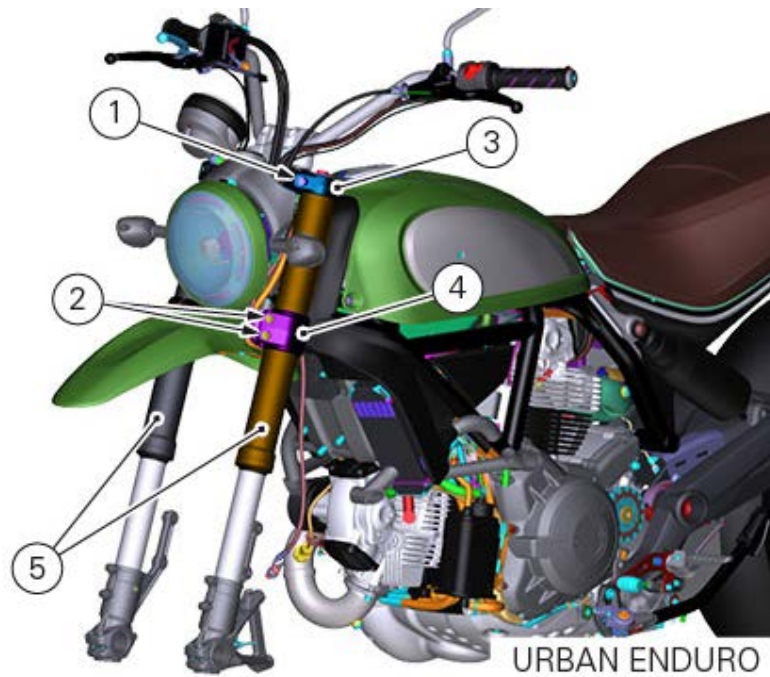

URBAN ENDURO

Refitting the steering tube components

Important

The steering tube bearings are identical but in no case may their components be swapped during refitting.

Clean all contact surfaces and lubricate with the recommended grease.

To fit the outer rings (C) of bearings to the steering tube, use tool (B) no. **88713.1062**. Proceed as follows:

- heat the steering tube to 150 °C;
- fit the outer rings (C) (upper and lower) in their seats on the steering tube;
- fit the fixed bush (G, with threaded hole) of the tool into the lower ring;
- fit the other movable bush (H) into the upper end of the tool and drive it fully home against the upper bearing race;
- tighten the nut (L), and use a wrench to seat the outer rings (C) fully in the steering tube;
- leave the tool fitted until the steering tube has cooled down to ensure that bearings are properly seated.

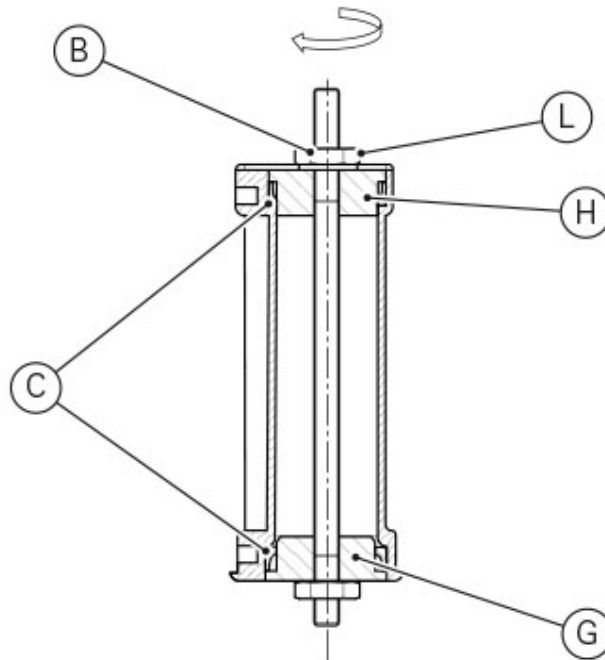

Fit spacer (9), dust seal (8) (with the rim facing upwards) and inner ring (7) of the lower bearing onto the

steering shaft after heating it for about 10 minutes to 120 °C.

Insert drift no. **88713.1072**. Push the inner ring (7) on dust seal (8), manually pushing for at least 10-15 seconds.

Lubricate the inner ring (7) with the recommended grease. Fit the ball race (6) on the steering shaft with the smaller diameter of the cage facing upwards, and grease the ball race.

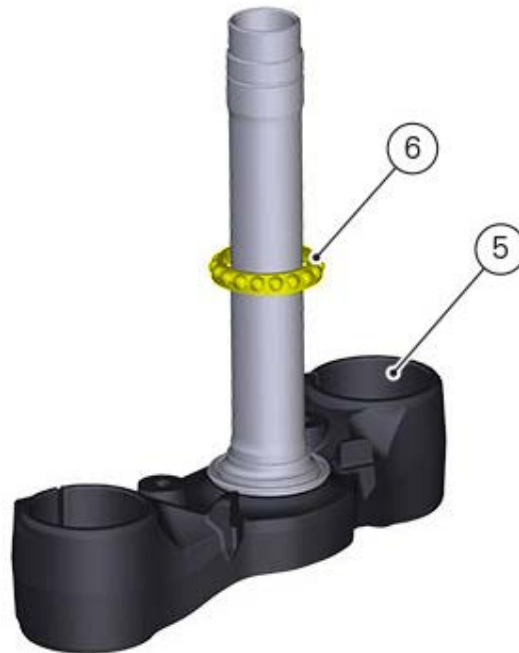
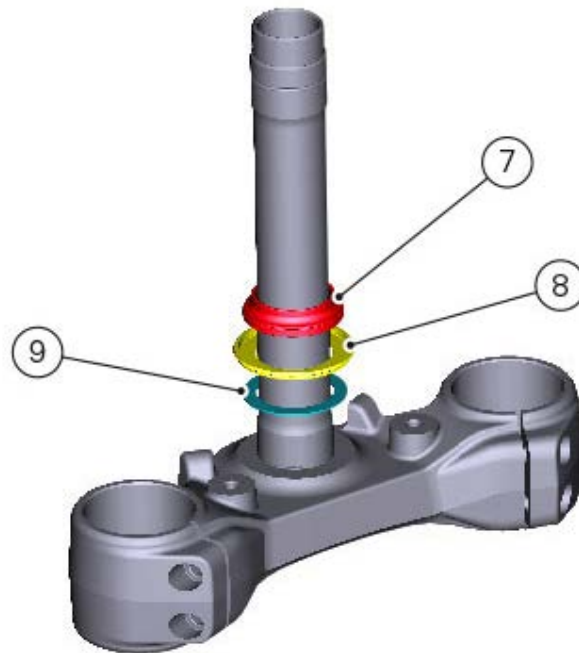

Fit the bottom yoke assembly to frame.
Fit the internal ring (3), the ball race (4) and the external ring (2).

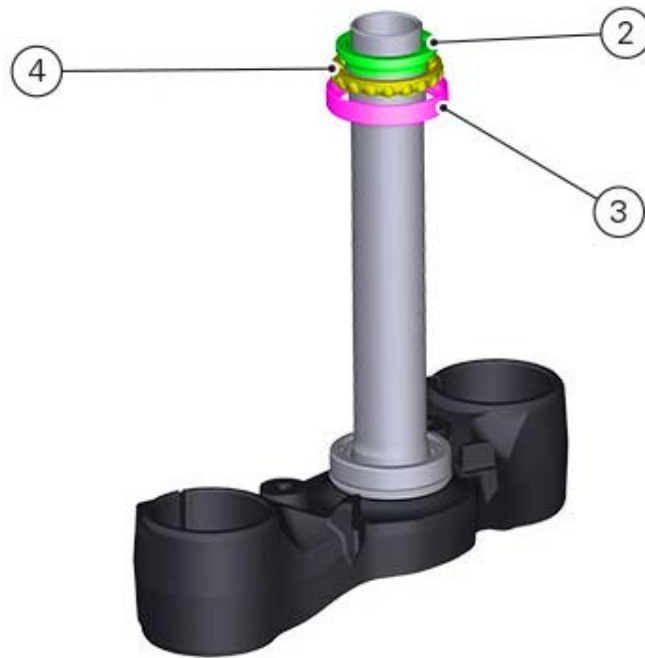

Position ring nut (1) and tighten it to the specified torque.



Refit the following components on the vehicle:

- Forks ([Refitting the front fork](#));
- Handlebar ([Refitting the handlebar](#));
- Front wheel ([Refitting the front wheel](#)).

Removing the steering tube components

Before removing the component, it is first necessary to remove the following parts:

Front wheel ([Removing the front wheel](#)).

Forks ([Removing the forks](#)).

Handlebar ([Removing the handlebar](#)).



Warning

All parts fitted to the steering head and bottom yoke, including wiring and hoses, can remain on the motorcycle provided they do not hinder the following operations.

Use tool part no. (A) **88713.1058** to loosen ring nut (1) and remove it from the steering.

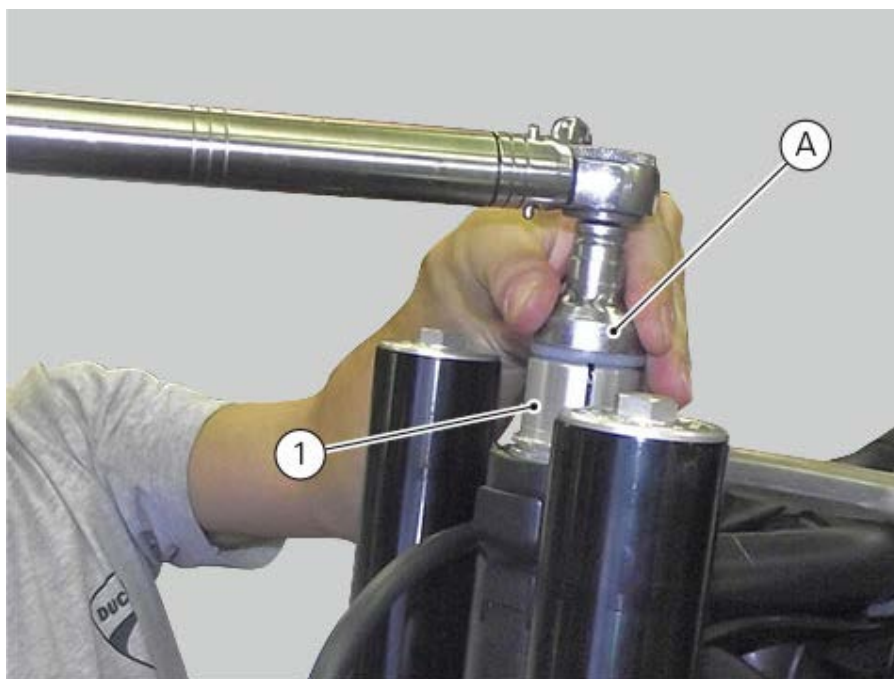

Remove seal ring (2), internal ring (3) and the ball race (4).

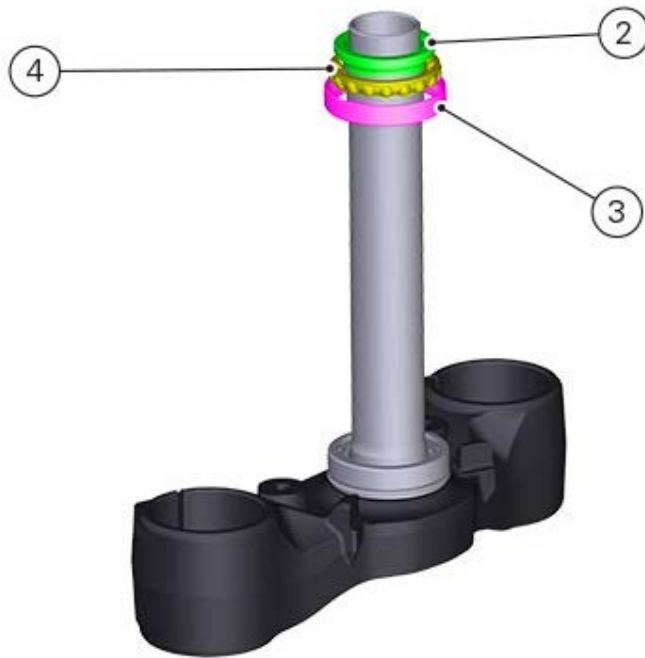

Remove the bottom yoke (5) complete with the steering shaft from the frame.
Remove the ball race (6).

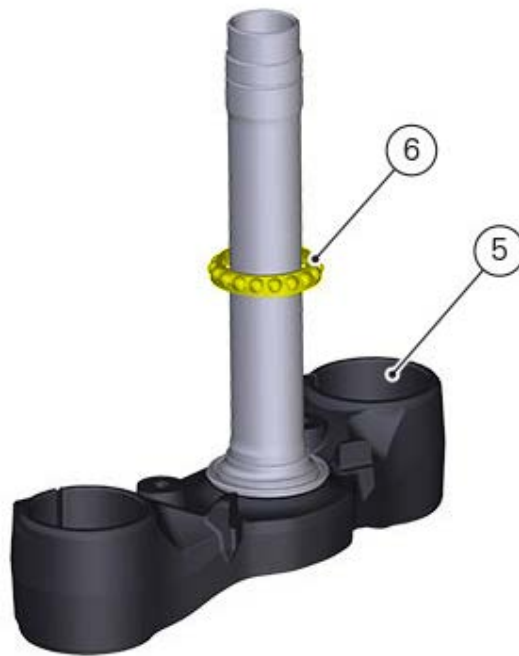

Use a universal puller to remove the internal ring (C), having care not to damage the seat.

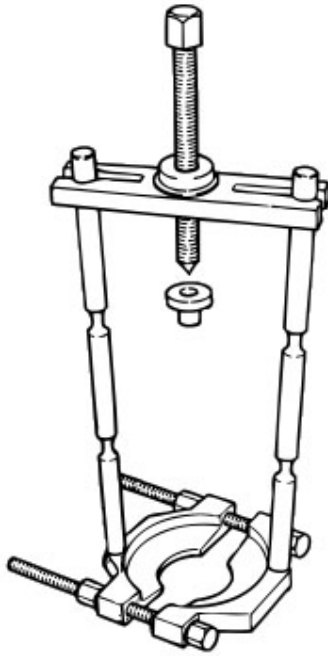

Important

The removed seals and bearings shall not be reused and must be replaced with similar new components.



Remove dust seal (8) and spacer (9).

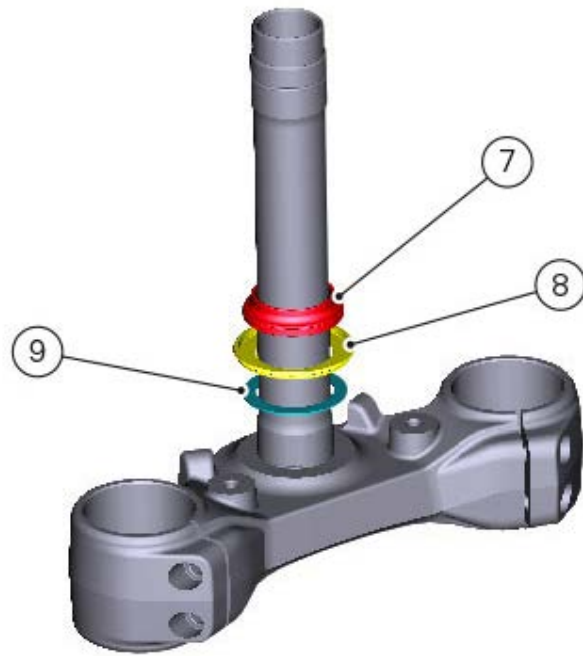

Steering angle adjustment

In this vehicle it is not possible to adjust the steering.

Adjusting the steering head bearing clearance

Adjust steering bearing clearance as explained in paragraph "[Adjusting the steering head bearing clearance](#)".

Refitting the rear suspension

Ensure that bushings (5) and (6) and spacer (7) are fitted on the frame.

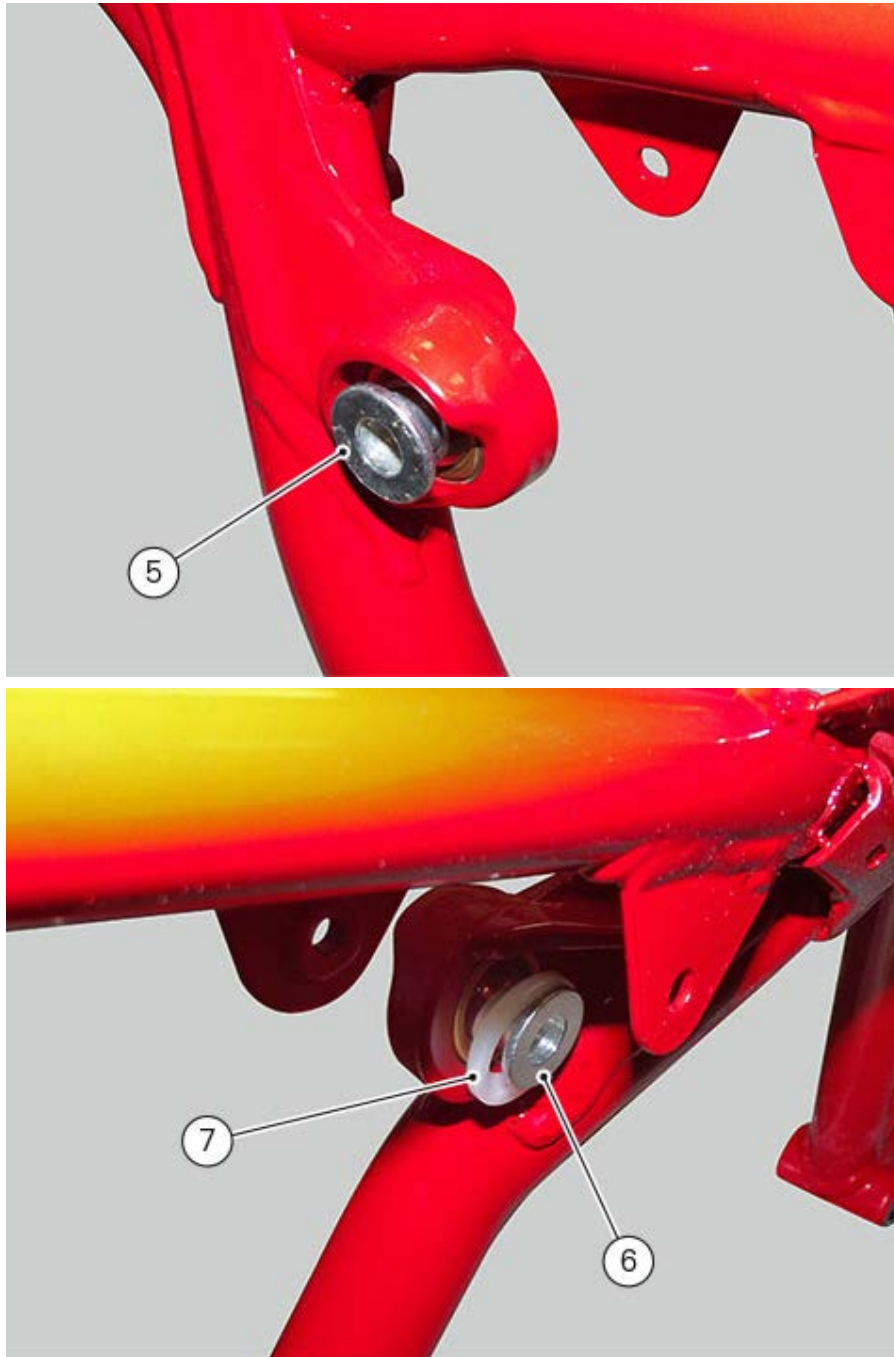

Insert the shock absorber upper part in the frame and insert screw (3).
Tighten nut (2) on screw (3) to a torque of $42 \text{ Nm} \pm 5\%$.

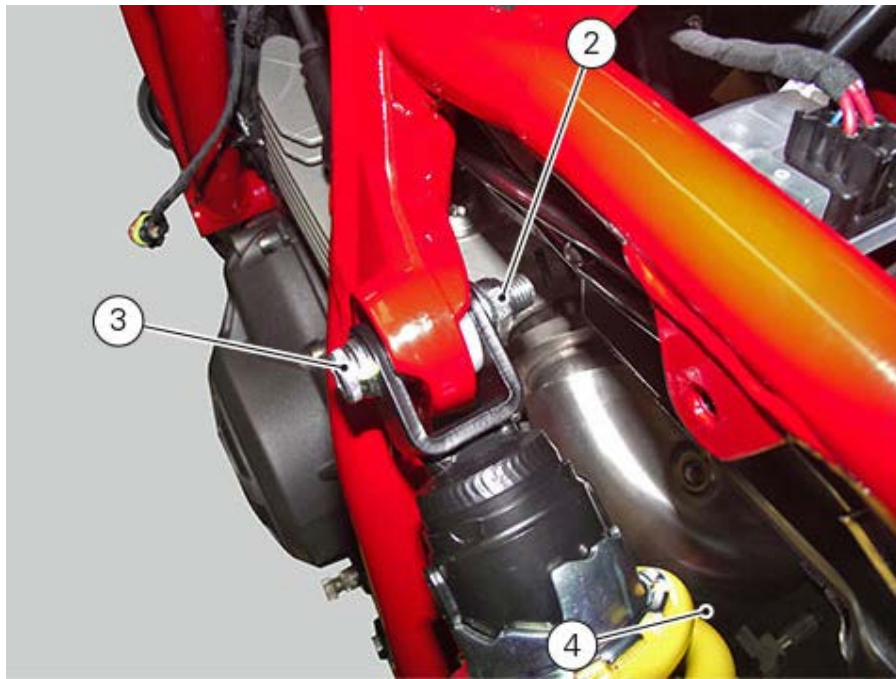

Apply specified grease to the thread and underhead of the lower screw (4), insert the shock absorber lower part in the swinging arm and tighten screw (4) to a torque of $42 \text{ Nm} \pm 5\%$.

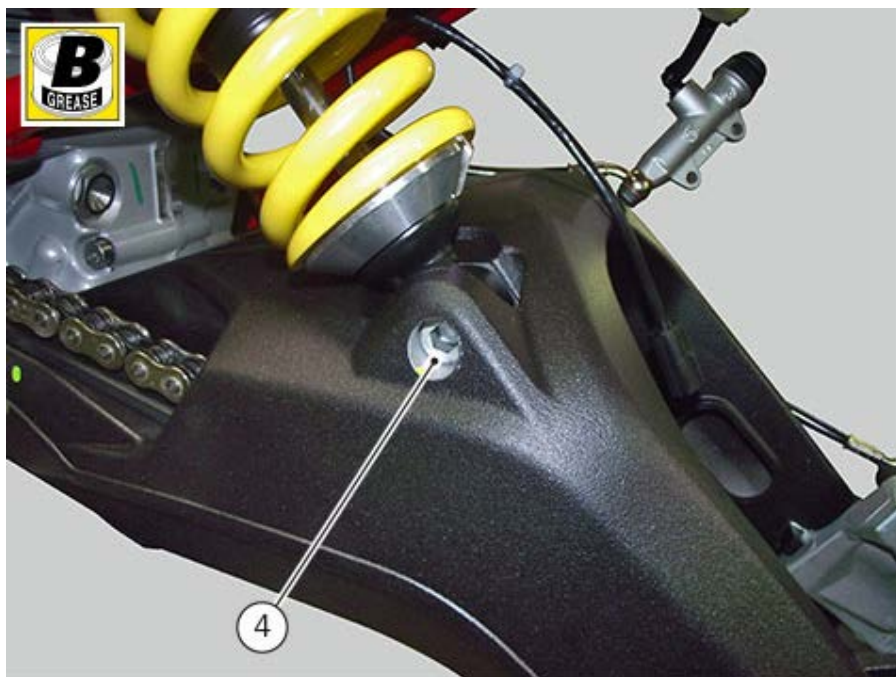

Overhauling the rear shock absorber

This shock absorber can not be overhauled.

Removing the rear shock absorber

Support the rear side of the vehicle in a suitable way.

To remove the rear shock absorber (1) from the vehicle, loosen nut (2) of the upper retaining screw (3).
Loosen the lower screw (4).
Remove the two screws (3) and (4).

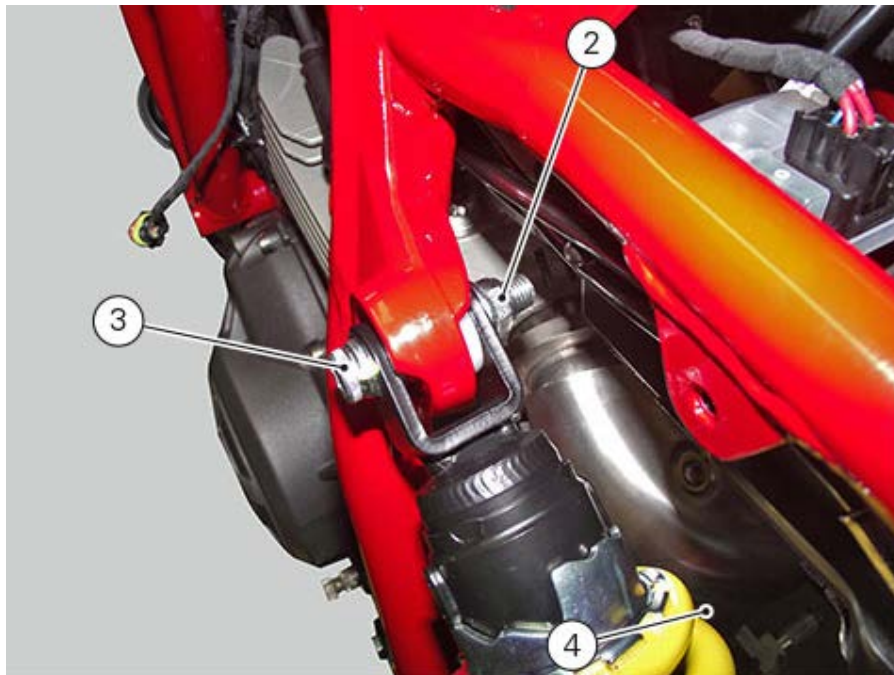
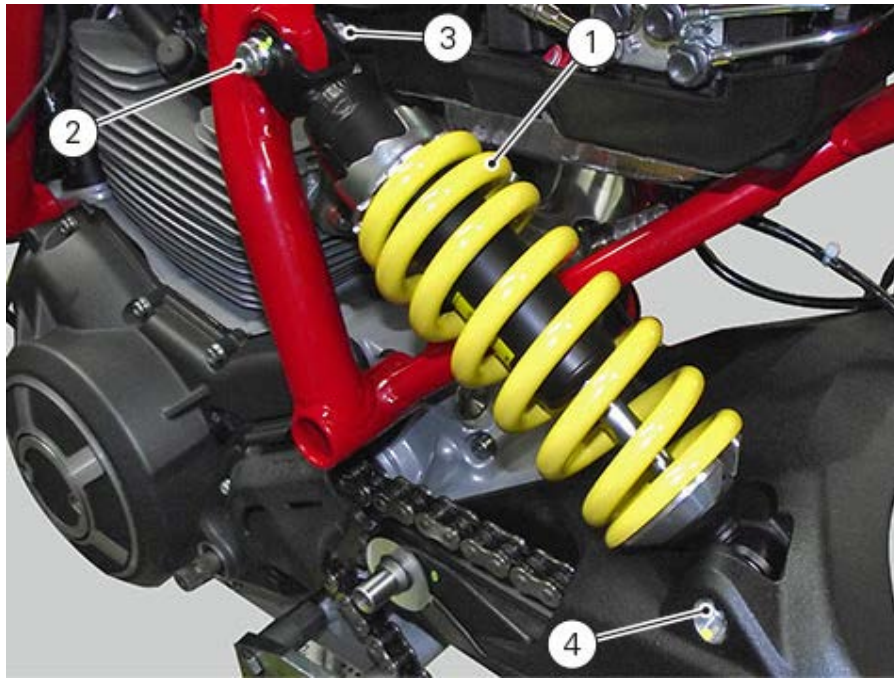

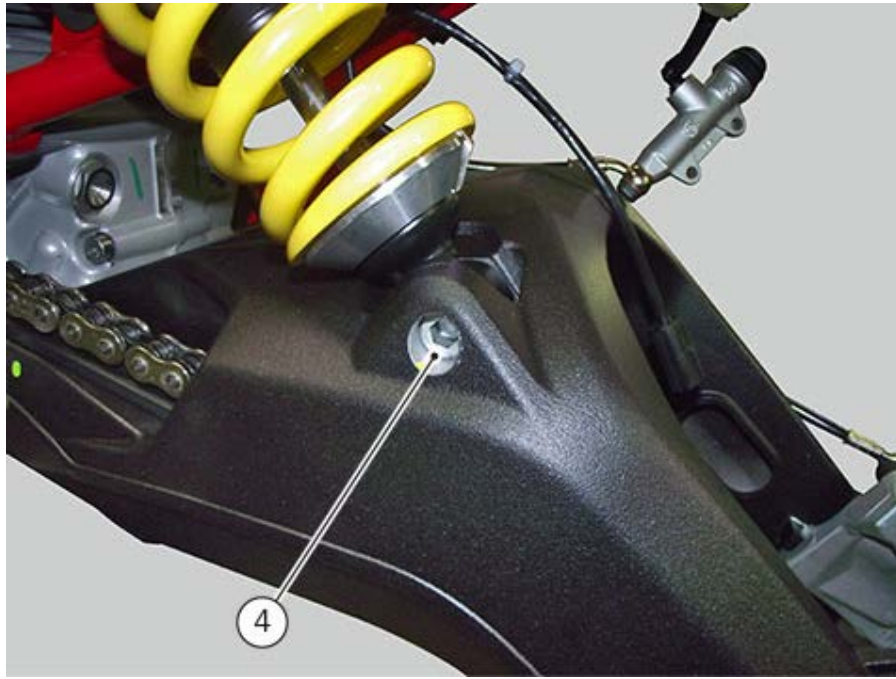

Rear suspension system

The rear suspension system uses a hydraulic monoshock absorber with spring preload that can be adjusted through ring nut (1). Shock absorber pivots onto a swinging arm at the bottom and frame at the top. The whole system gives the motorcycle excellent stability.

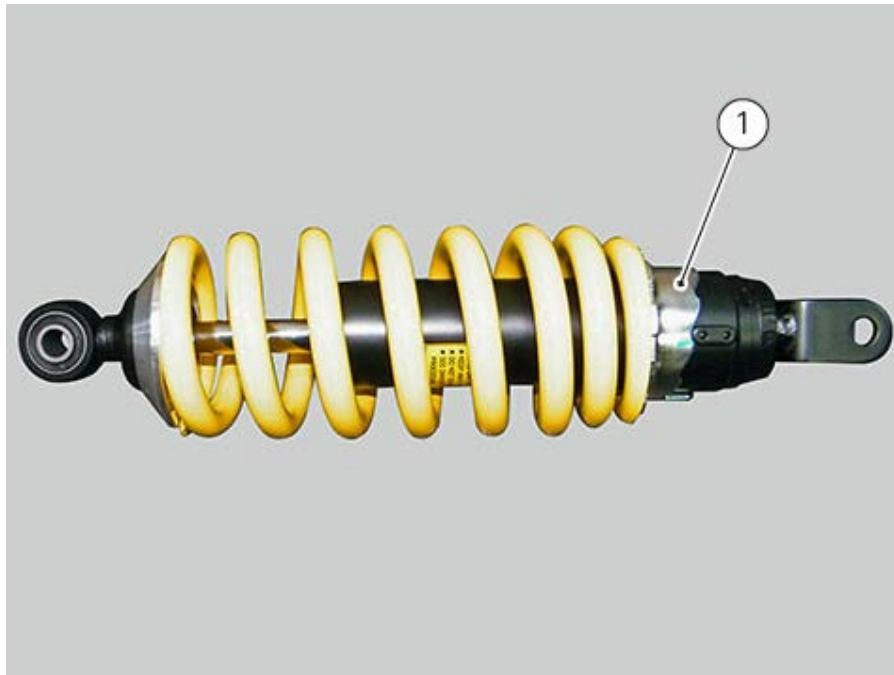

The only possible adjustment on the rear shock absorber is spring preload. Turn adjuster (1) using the suitable wrench to set. Turn adjuster clockwise to decrease spring preload, turn counter clockwise to increase preload.

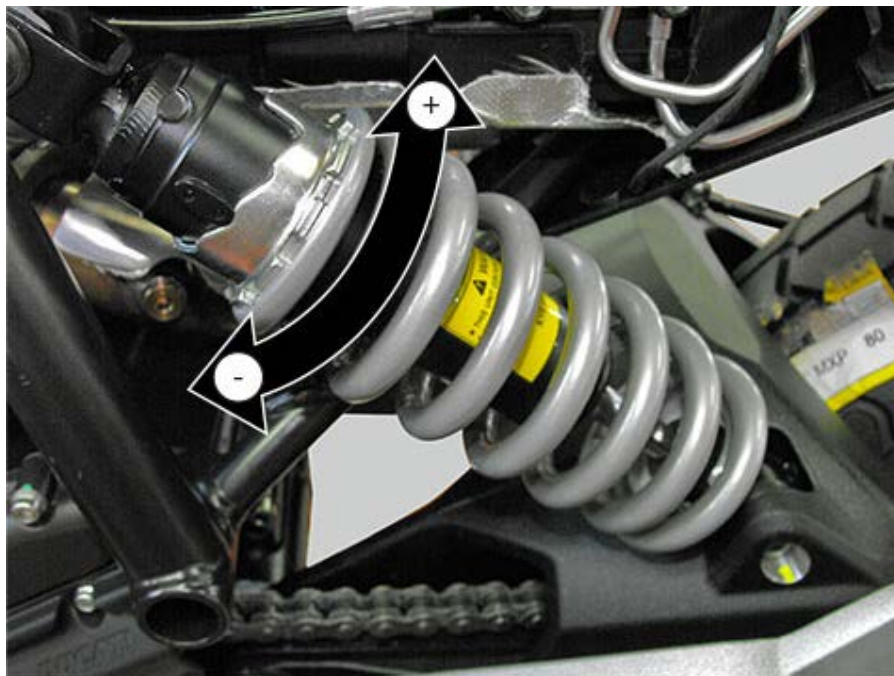

Refitting the rear swinging arm

Use grease to lubricate the bearings on the crankcase.

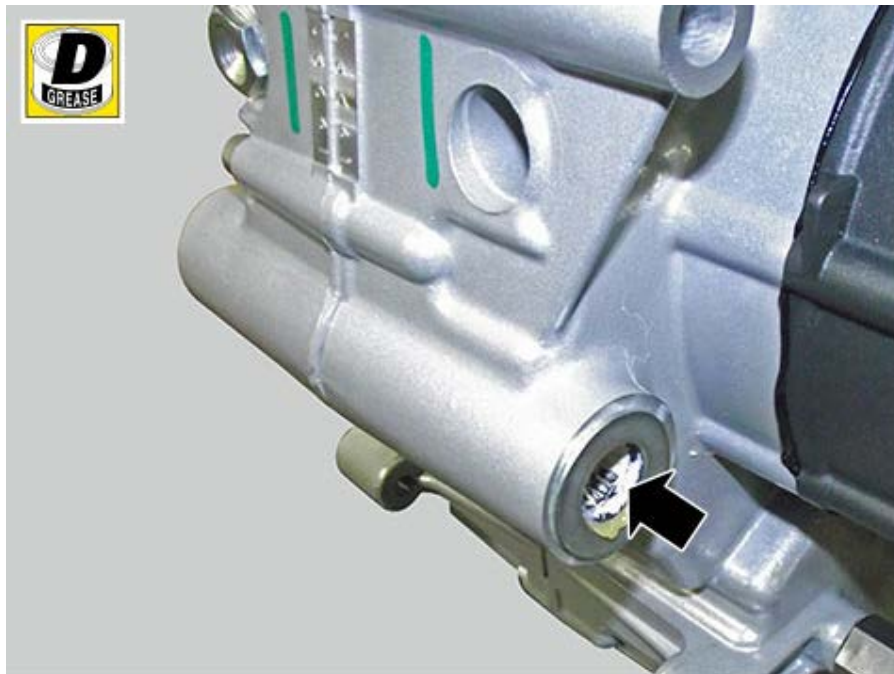
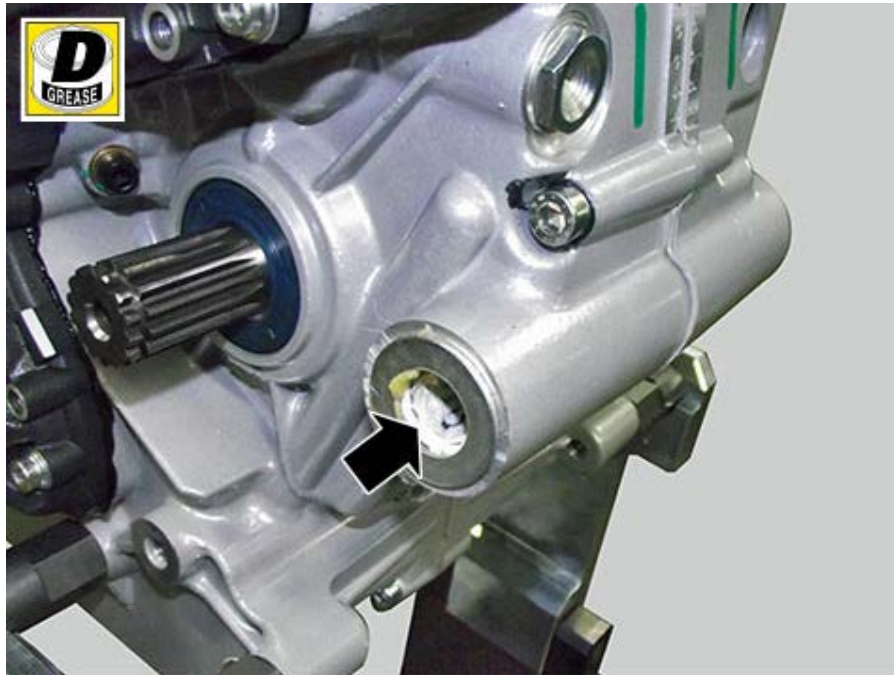

Position the shims as described in chapter "[Overhauling the rear swinging arm](#)".

Install circlip (7) onto shaft (4).



Bring the swinging arm seat close to the seat on the crankcase.
Insert pin (4) fully home.

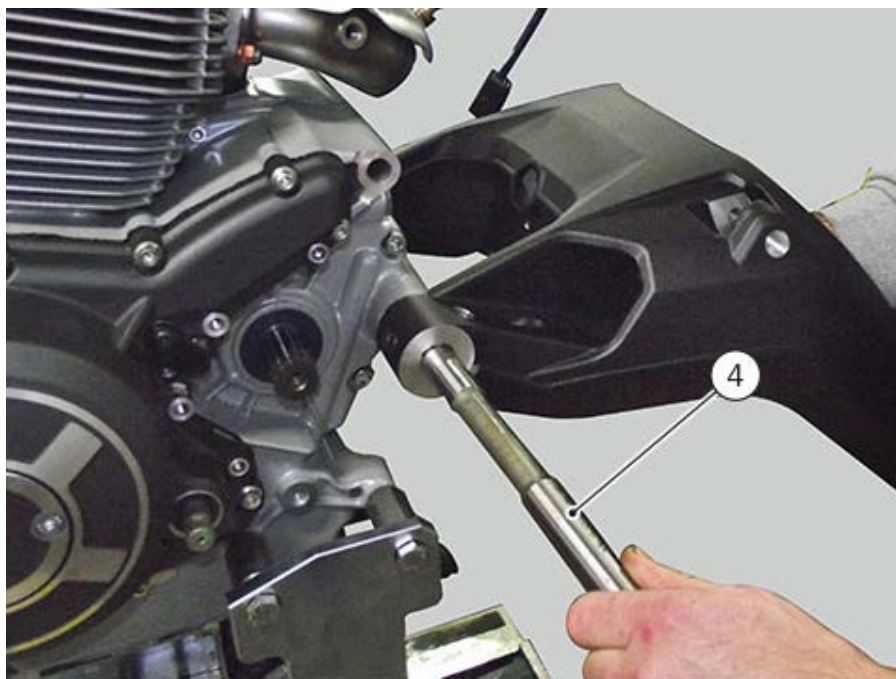

Lubricate with specified product the swingarm shaft in the indicated product.



Fit circlip (3) in wheel shaft (4).

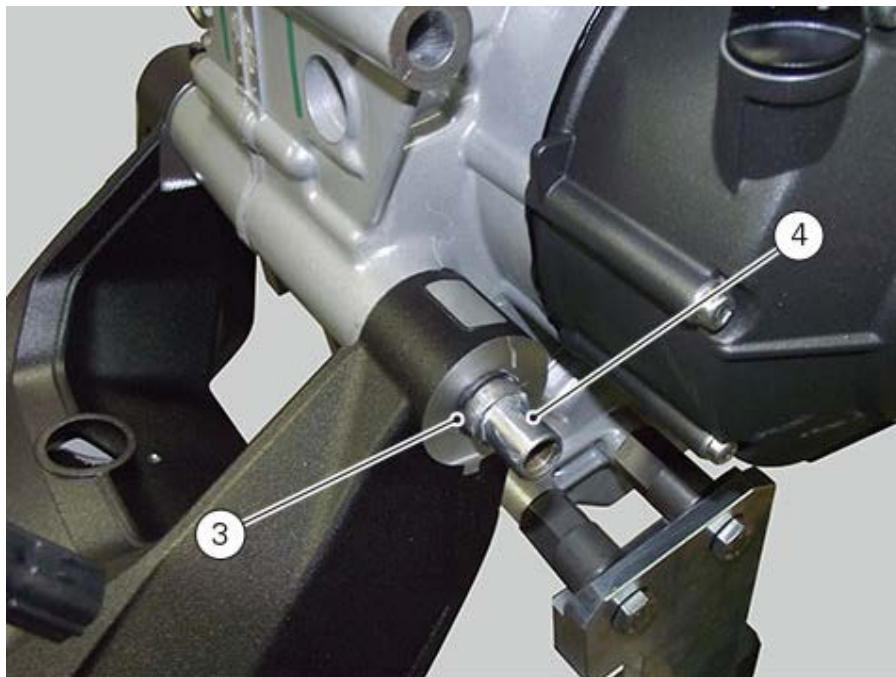

Insert screw (5) applying the specified product, and tighten it to a torque of $18 \text{ Nm} \pm 5\%$.

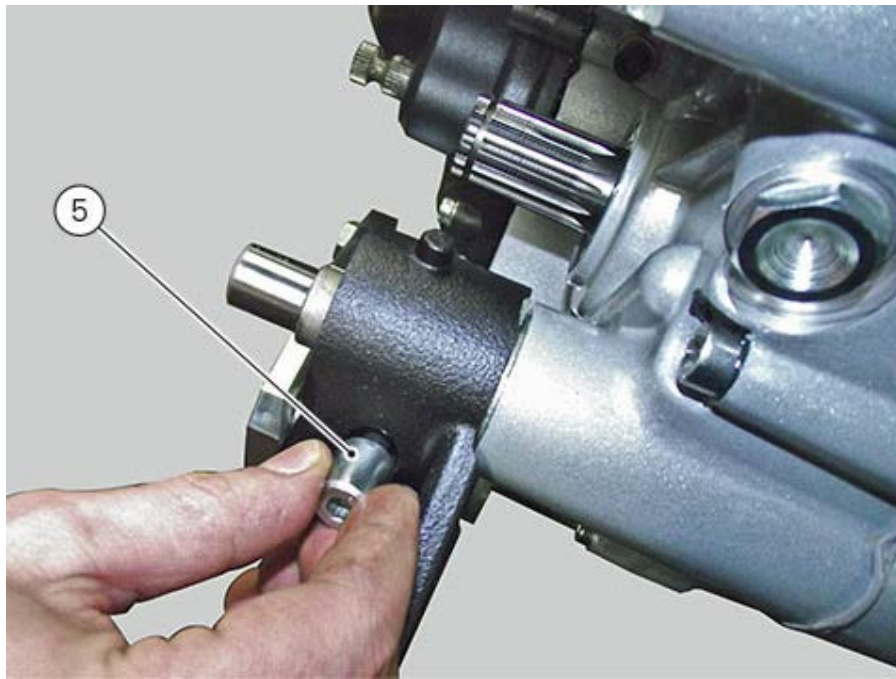

Lock shaft using circlip (8).



Refit chain guard (1) by tightening the two screws (2) to a torque of $5 \text{ Nm} \pm 10\%$.

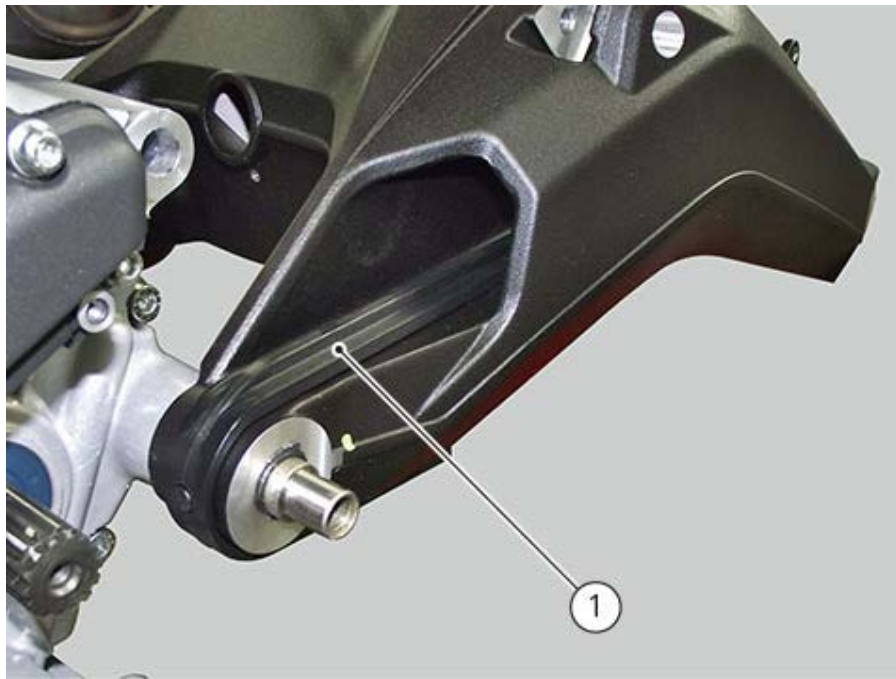

- Refit the exhaust silencer ([Refitting the silencer](#)).
- Refit the rear calliper ([Refitting the rear brake calliper](#)).
- Refit the rear shock absorber ([Refitting the rear shock absorber](#)).
- Refit the rear wheel ([Refitting the rear wheel](#)).
- Refit the footpeg holder plate ([Refitting the footpeg support](#)).

Overhauling the rear swinging arm

Select the shim (6) size upon swinging arm refitting.
To check the end float, proceed as follows:

- Fit spacer (6), lubricated with the indicated product, with **1.8 mm** thickness on the vehicle left side;
- insert the shaft from the left side keeping the swinging arm left section against the engine, insert a 1.8-mm shim from the other section and check with a feeler gauge or calibrated shims the clearance on the engine side.

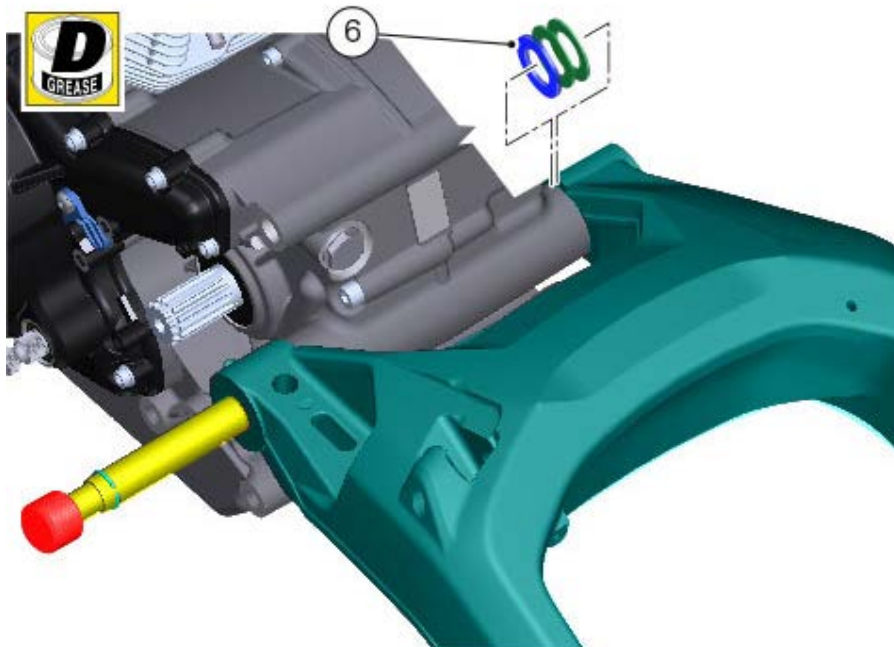
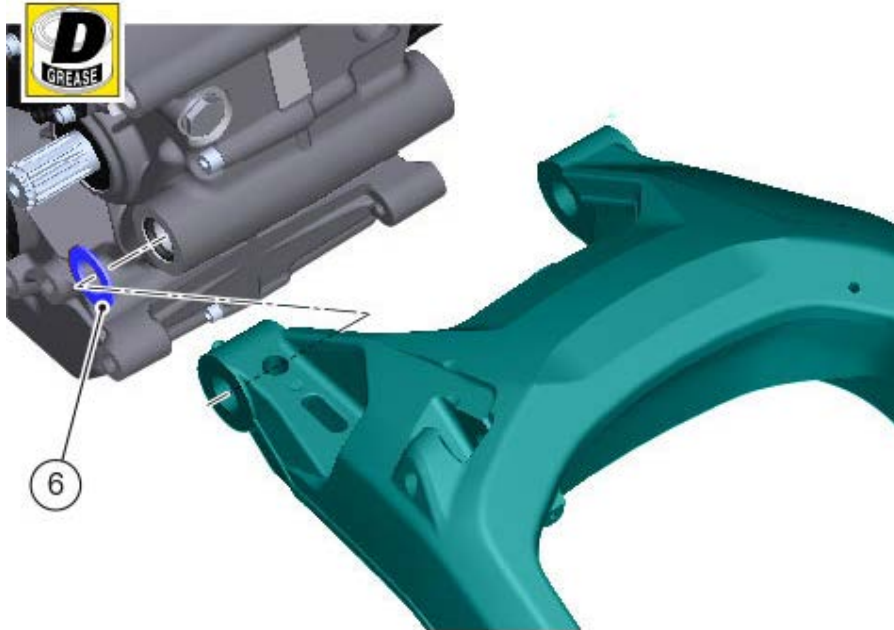

The maximum side play allowed is **0.10 mm**.

If the gauge size is **0.18mm** and it fits with difficulties, do not fit any shim. If this is not the case, the available shim sizes are **0.20 mm** and **0.10** with which it is possible to restore the specified play.

Example:

Measured play	Left-hand side shims	Right-hand side shims

0.10	-	no.1 shim (0.10 mm)
0.20	no.1 shim (0.10 mm)	no.1 shim (0.10 mm)
0.50	no.1 shim (0.20 mm)	no.1 shim (0.20 mm) + no.1 shim (0.1 mm)

 **Important**

The shims with greater size have to be fitted on the swinging arm right-hand side.

The thinner shim must always be in contact with the swinging arm.

Do NOT fit shims with size equal to **0.1** on the left side.

The maximum value of the set of shims on the left must be **2mm (1.8 + 0.2max.)**

The maximum swinging arm rear end play is within **1 mm**.

Inspecting the swinging arm shaft

Before refitting the swinging arm shaft (4), check it carefully for distortion.
Turn the shaft on a reference surface and measure distortion using a feeler gauge.

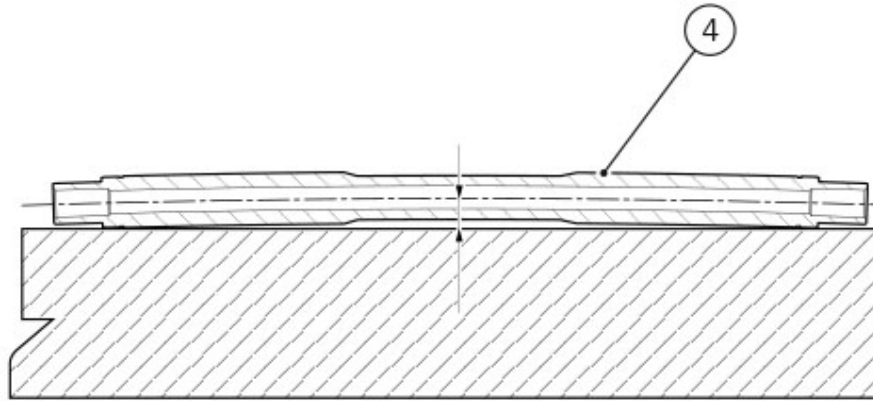

Removing the swinging arm

Remove the exhaust silencer.

Remove the rear wheel ([Removing the rear wheel](#)).

Remove the rear calliper ([Removing the rear brake calliper](#)).

Remove the shock absorber ([Removing the rear shock absorber](#)).

Remove the footpeg holder plates ([Removing the front footpeg support](#)).

Remove the chain.

Remove the chain guard (1) loosening the two screws (2).

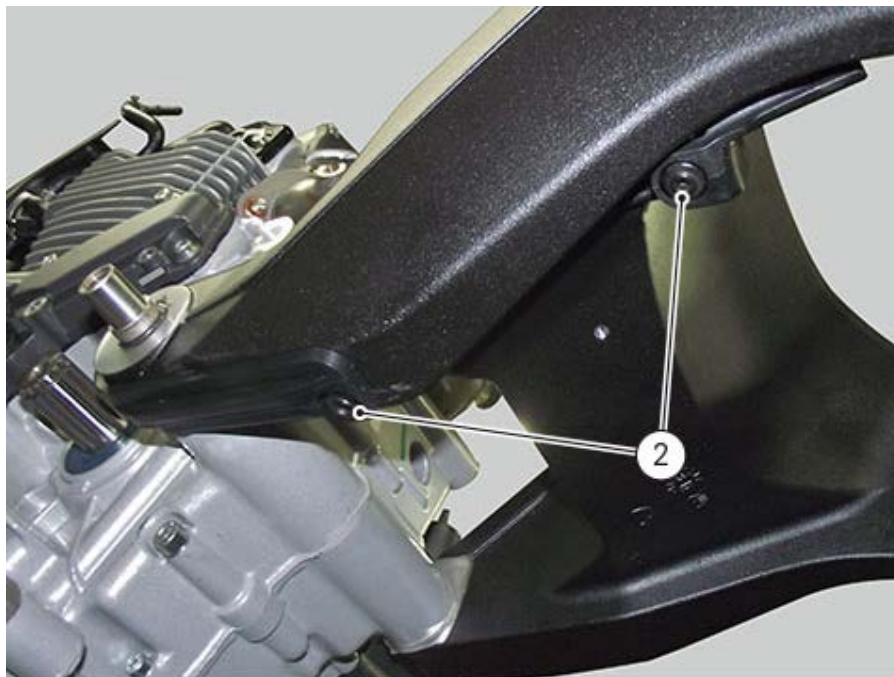
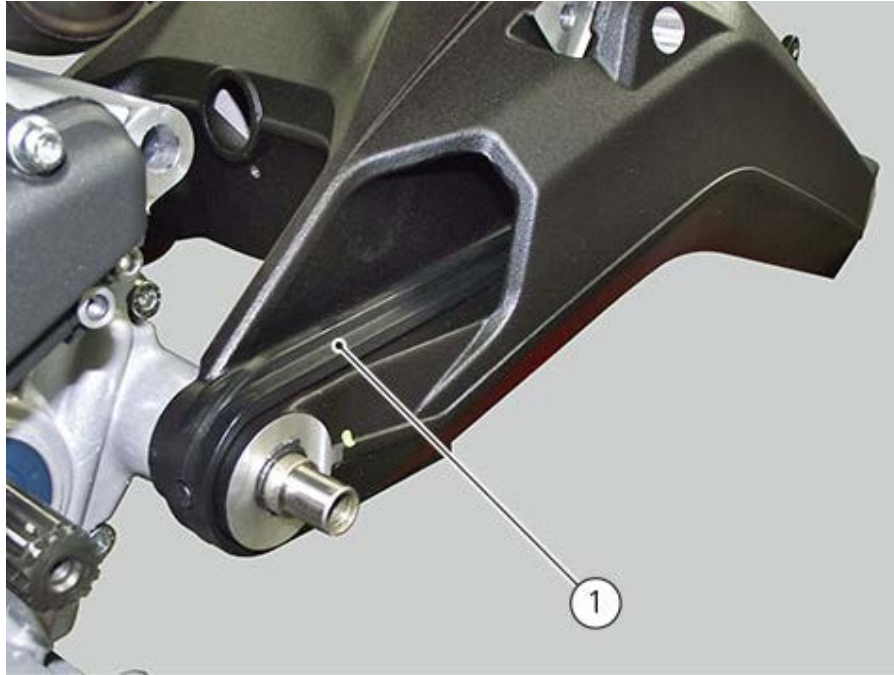

Remove retaining circlip (3) of the swingarm shaft (4).

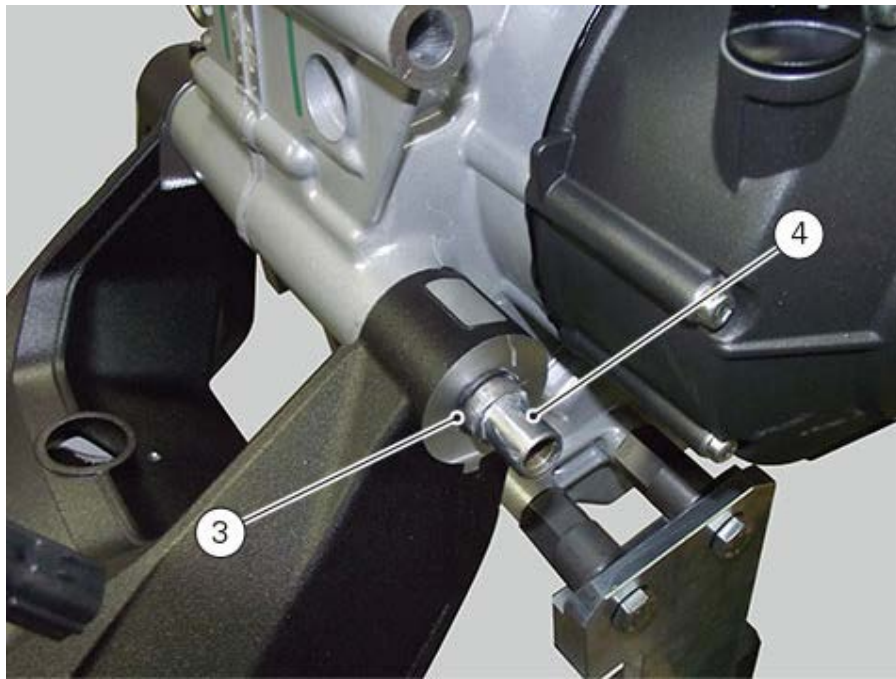

Loosen screw (5) and remove it from the swinging arm.

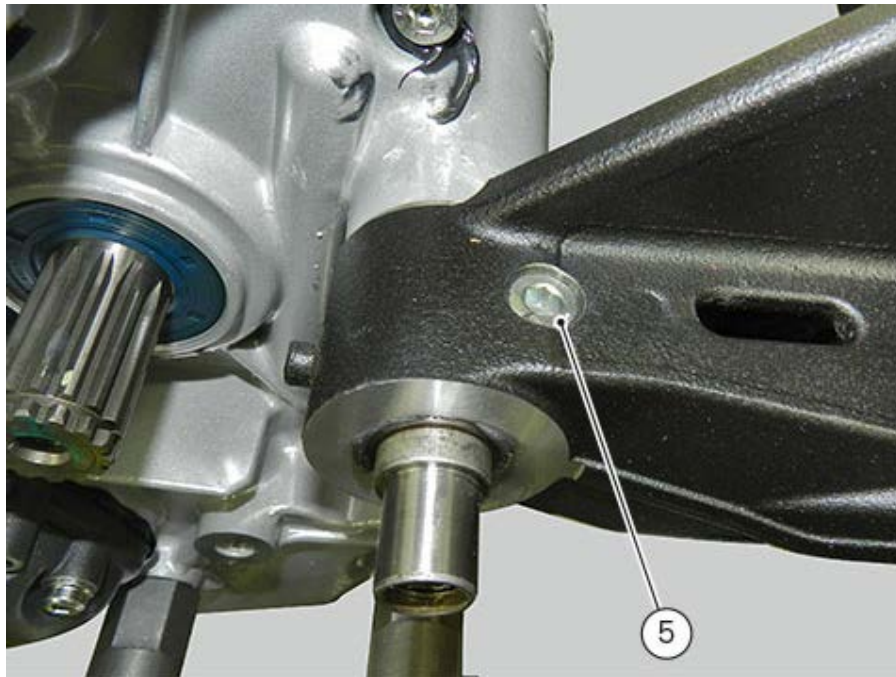

Slide out swingarm shaft (4) from the vehicle LH side.
Remove the swinging arm.

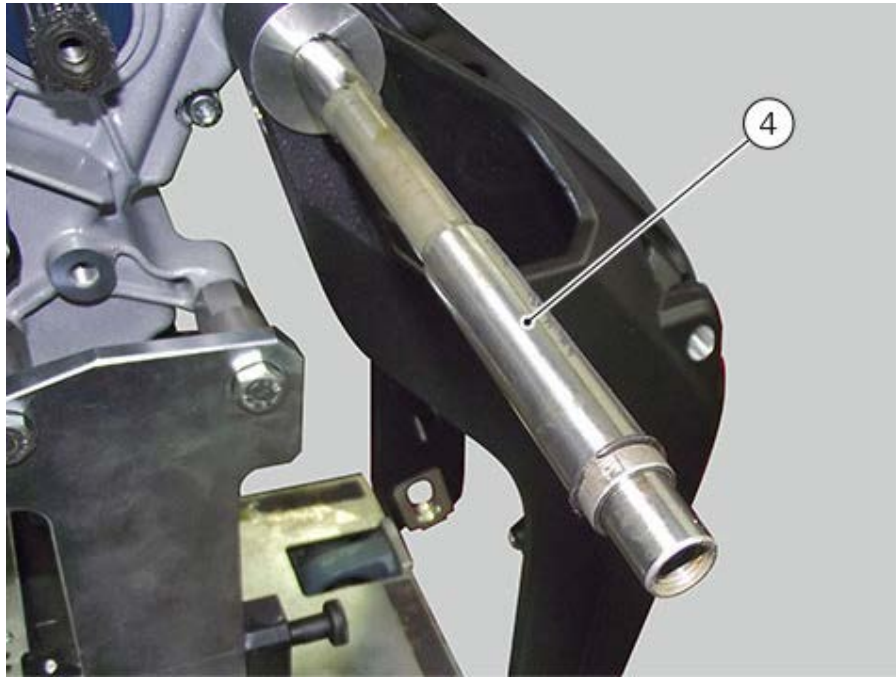

Lubricating the chain

O-ring chains have sealed, life-lubed link studs and bushes.

However, these chains need to be lubricated at regular intervals to protect metal parts of the chain and the O-rings.

Lubrication also serves to keep the O-rings soft and pliable to ensure the maximum sealing efficiency.

Using a brush, apply a thin protective layer of high-density gearbox oil along the entire length of the chain both inside and outside.

Washing the chain

Chains with O-rings must be washed in oil, diesel fuel or paraffin.
Do not use fuel, trichloroethylene or other solvents which will damage the rubber O-rings.
For the same reason use only sprays specifically formulated for use with O-ring chains.

Refitting the rear sprocket

If removed, screw pins (5) to the rear sprocket flange (3) with specified threadlocker applied in the indicated point.

Tighten the pins to a torque of $46 \text{ Nm} \pm 5\%$.



Position rear sprocket (1) on rear sprocket flange (3) and start nuts (2).

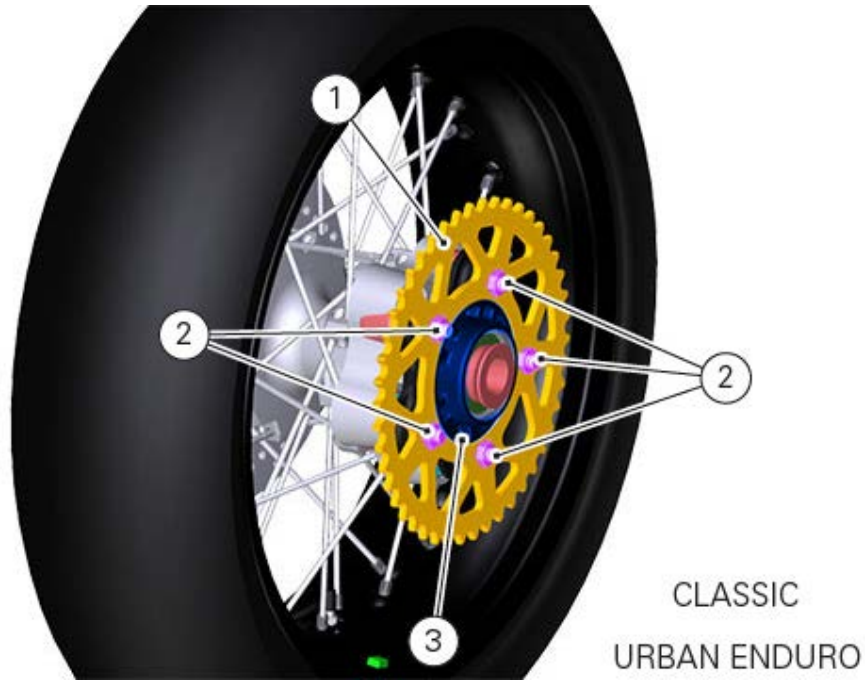
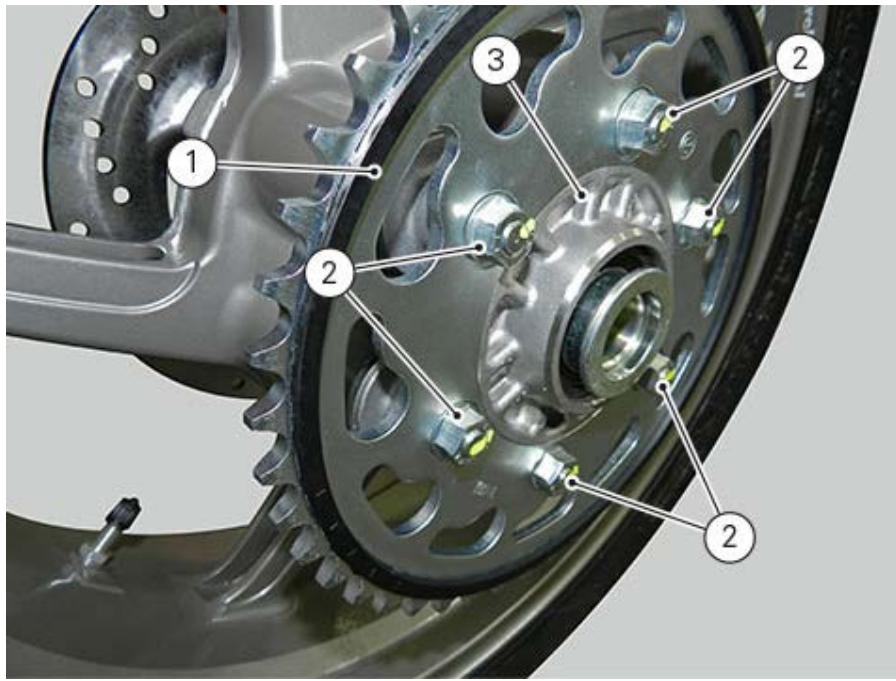

Insert spacer (4) fully home.
Lubricate the pins with the recommended product.



Position the rear sprocket flange-rear sprocket assembly in the rear wheel.
Fit spacer (6) and tighten nuts (2) to a torque of $46 \text{ Nm} \pm 5\%$.

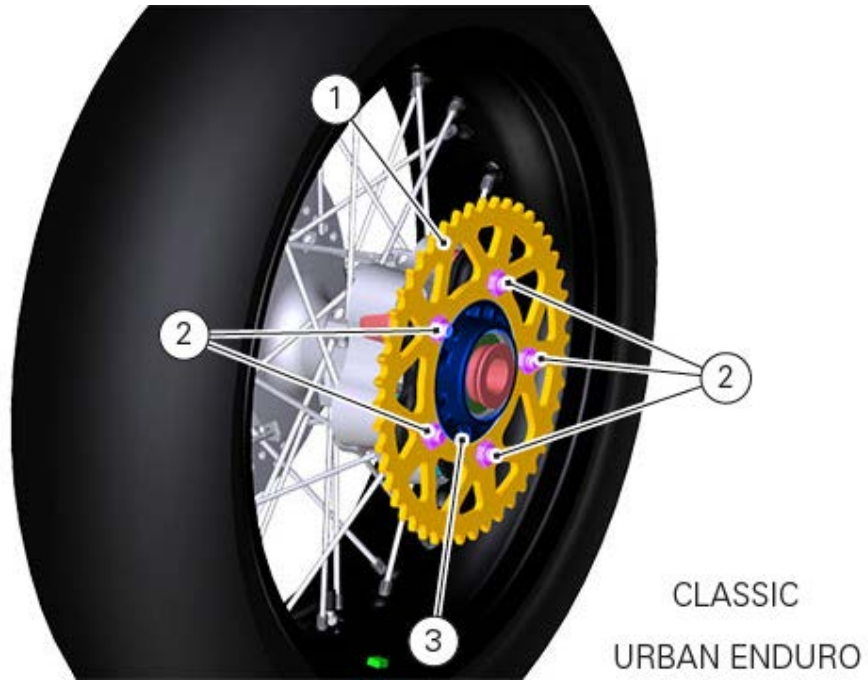
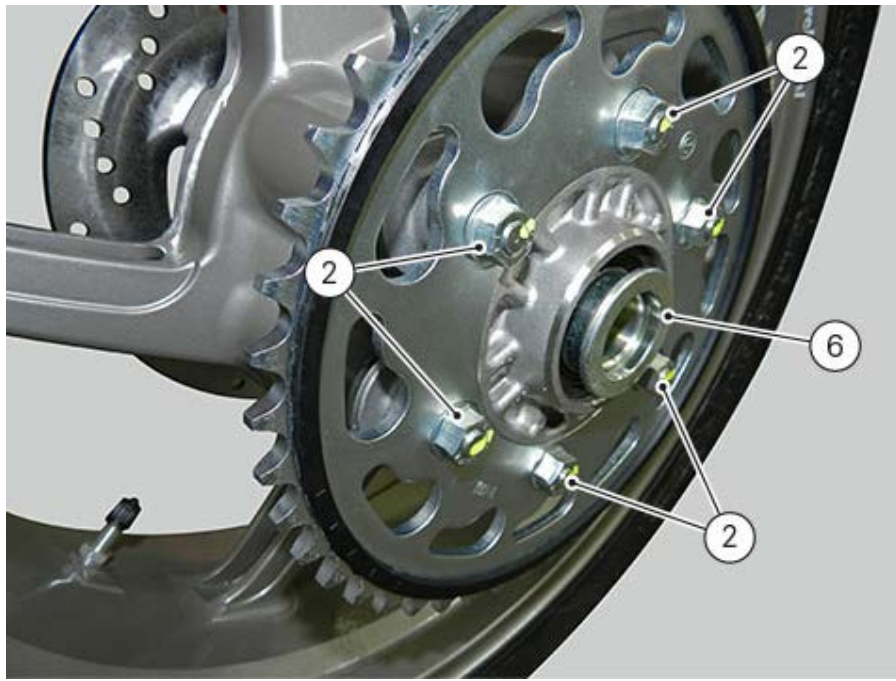

Refit the rear wheel ([Refitting the rear wheel](#)).

Removing the rear sprocket

Remove the rear wheel ([Removing the rear wheel](#)).

Loosen nuts (2) retaining rear sprocket (1) to rear sprocket flange (3).

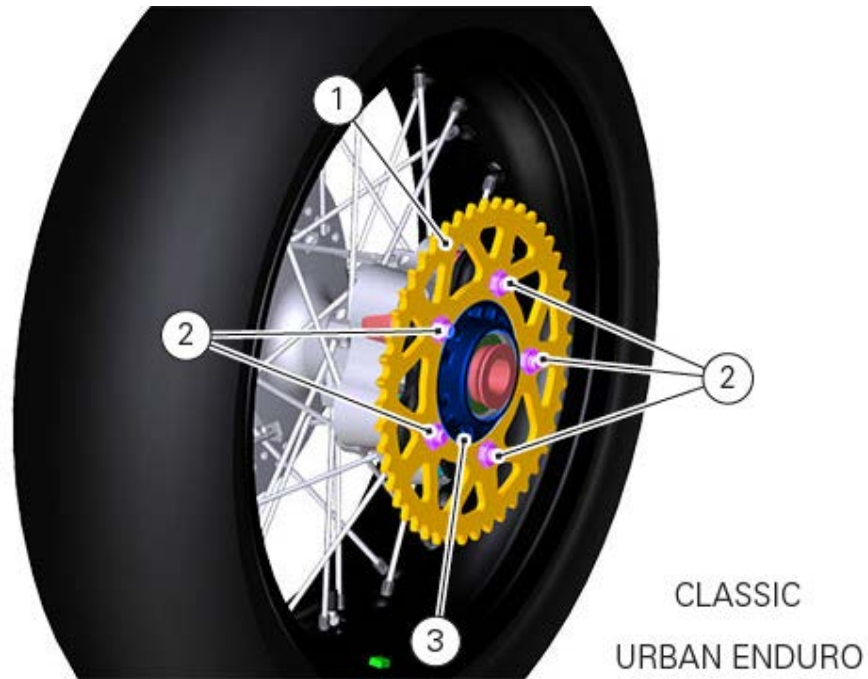

Remove the rear sprocket flange (3) from the rear wheel.
Remove spacer (4).



Loosen the nuts retaining the rear sprocket to the rear sprocket flange previously loosened.

Refitting the front sprocket

Check that the splines of the gearbox secondary shaft and the sprocket are in perfect condition. Insert the sprocket on the gearbox secondary shaft and push it over the groove (7).

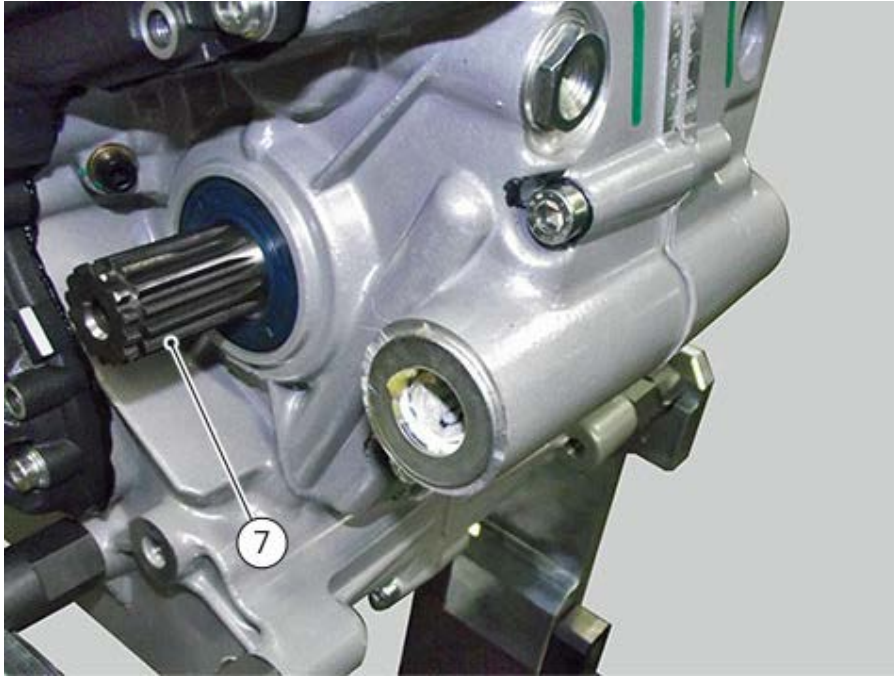

Respect the positioning shown in figure.

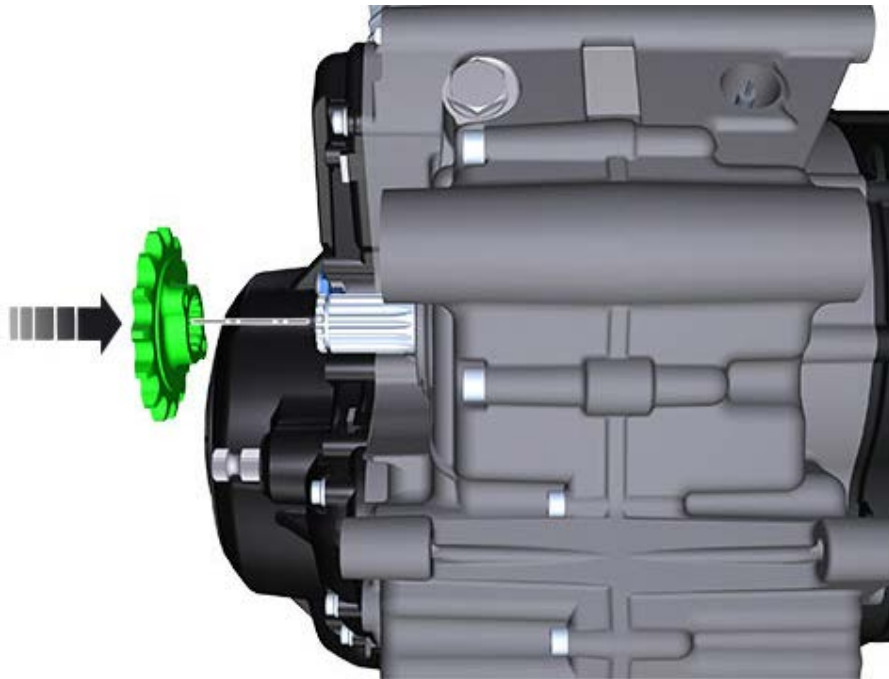

Insert stop plate (4) on the gearbox secondary shaft (5) and rotate it inside groove (7) until the plate holes match the sprocket threaded holes: orient the stop plate with the rounded edge facing the sprocket. Apply threadlocker on screw threading (3). Engage the first gear.

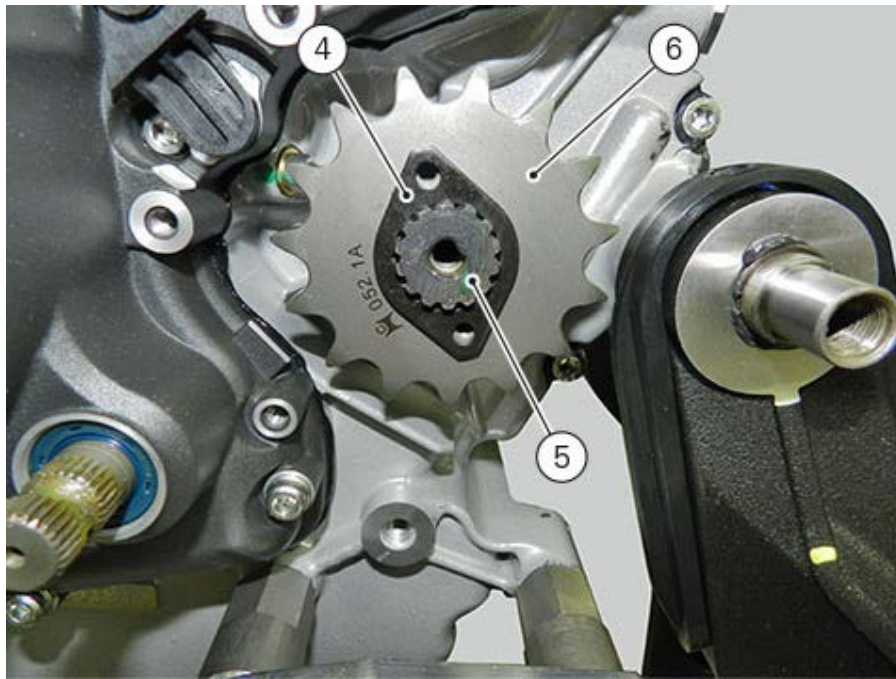

Tighten the screws (3) to a torque of $6 \text{ Nm} \pm 5\%$.



Fit the chain and close it using the tool (X) no. **88713.1344**, which was used to open the chain. The tool consists of a holder (A), a punch (B), body (C) and two wrenches (D) and (E) and a plate holder (F). Connect the two ends of the chain with the external link, and manually fit the plate onto the pins. Warning

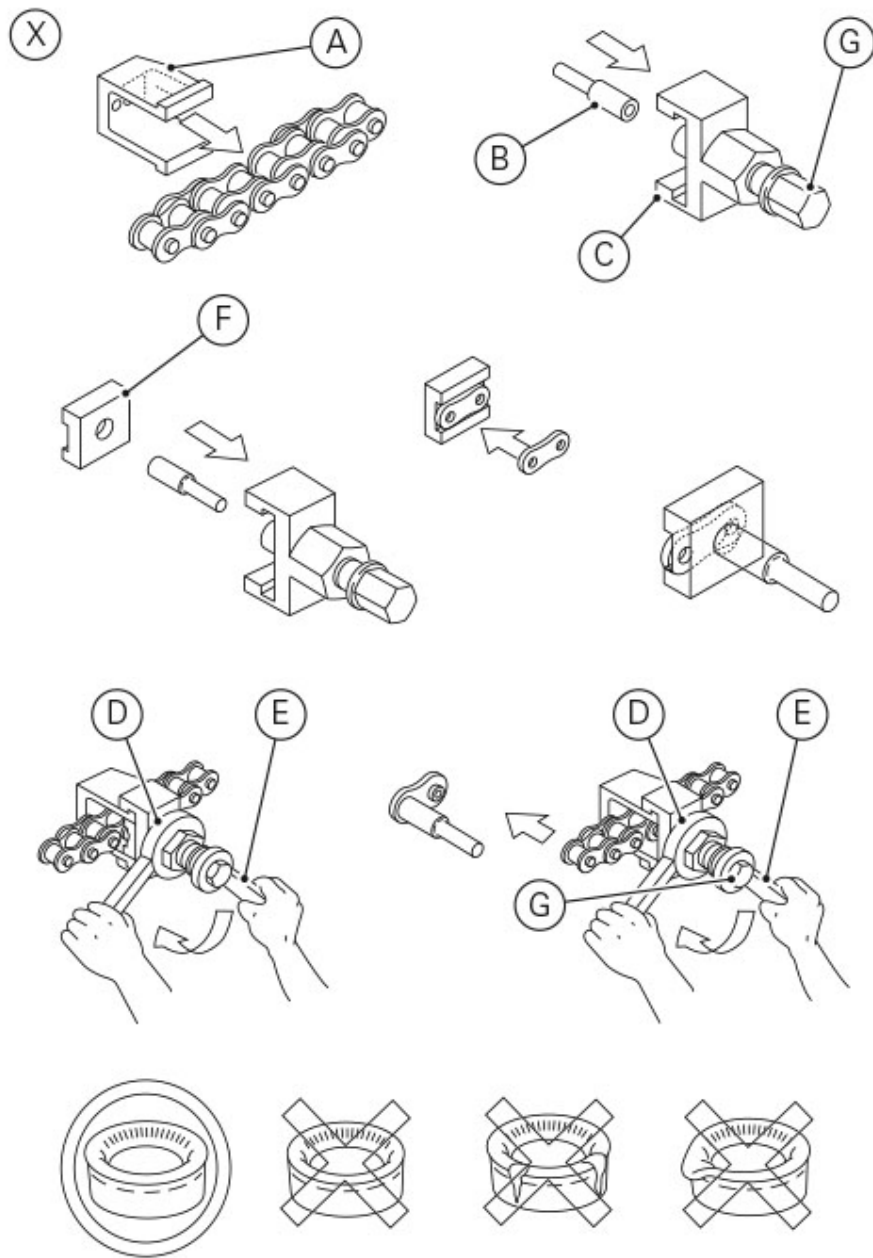

Tension the belt.

Fit the sprocket cover (1) and tighten the screws (2) to a torque of $6 \text{ Nm} \pm 10\%$.

Removing the front sprocket

Undo the screws (2), and remove the chain cover (1).
Slacken the chain ([Adjusting the chain tension](#)).

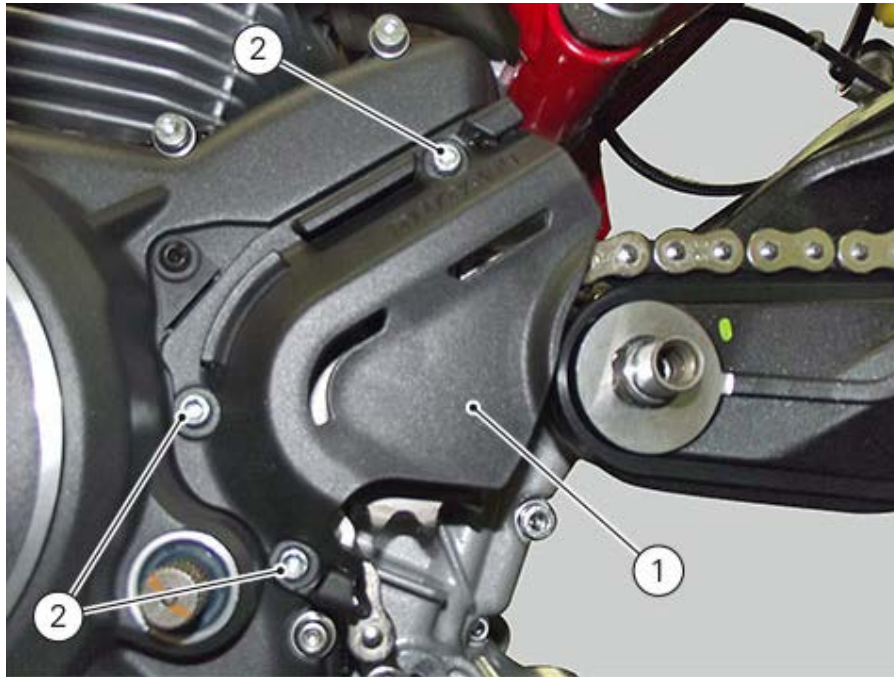

Remove the chain using tool (X) part no. **88713.1344**.

The tool consists of a holder (A), a punch (B), a body (C) and two wrenches (D) and (E).

Fit the link to be opened into the holder (A).

Fit the punch (B) into the body (C) and manually undo the screw until the punch no longer protrudes.

Fit the holder (A) and the link into the body (C).

Manually turn the bolt (F) on body (C) so that the punch (B) gets against the pin, taking care that they are aligned. Fit the hexagon wrench (D) into the hexagonal part of the body (C) and the wrench (E) onto the bolt.

Turn clockwise the bolt (F) until the pin comes out.

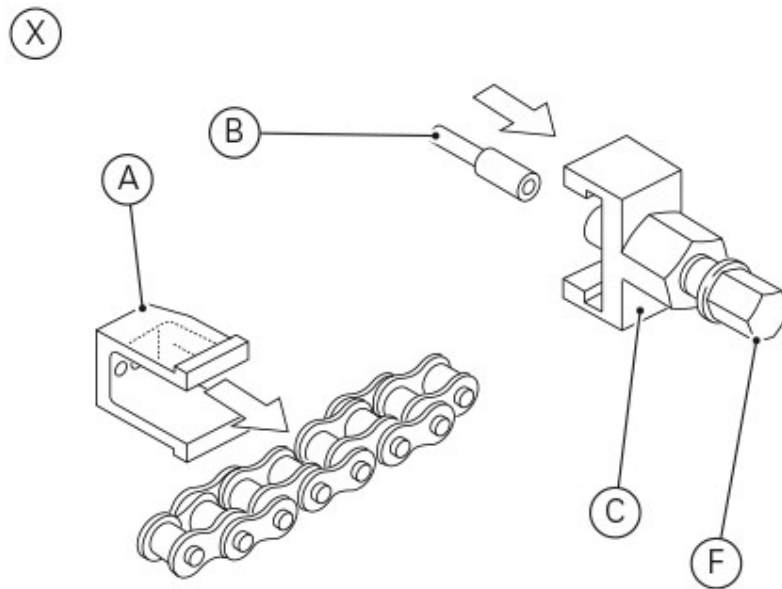

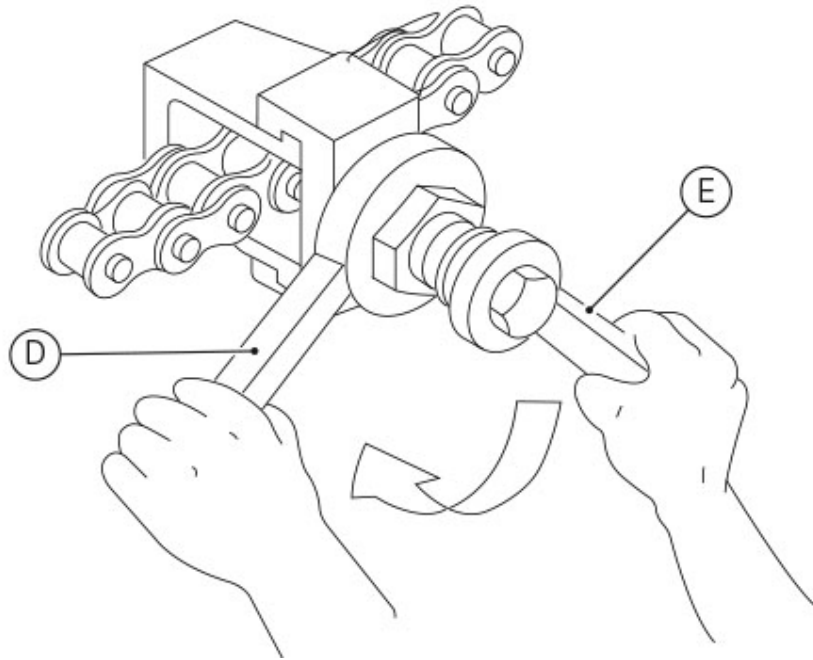

Remove the chain.

Engage a low gear and loosen the two screws (3) on the sprocket stop plate (4).



Remove plate (4) of the gearbox secondary shaft (5).

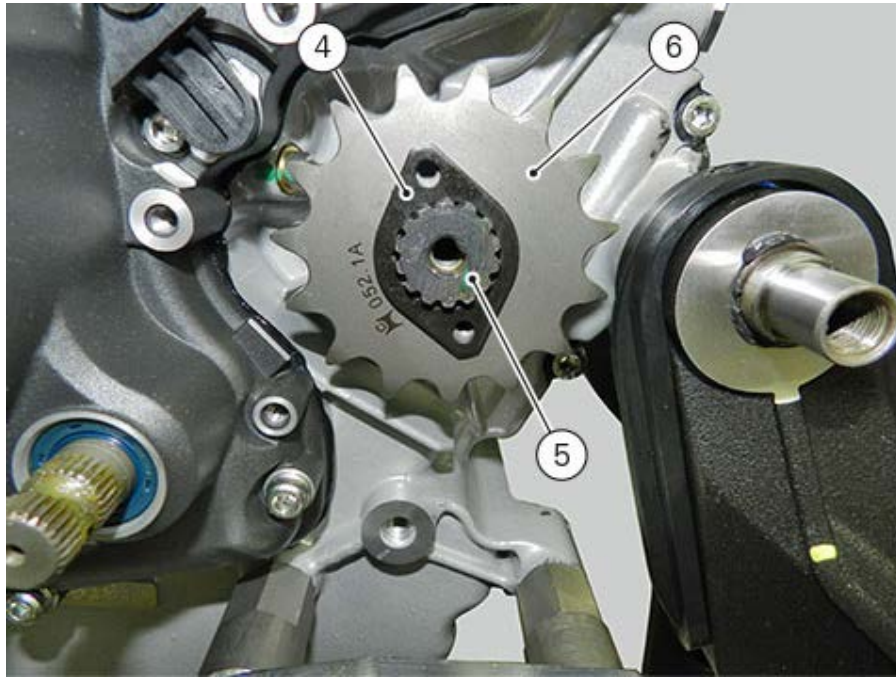

Remove the front sprocket (6) from the gearbox secondary shaft (5).

Inspection of the final drive

To check the final drive wear, visually check the front sprocket (1) and the rear sprocket (2). If the teeth are worn as shown in the figure (dotted line), the final drive must be replaced.

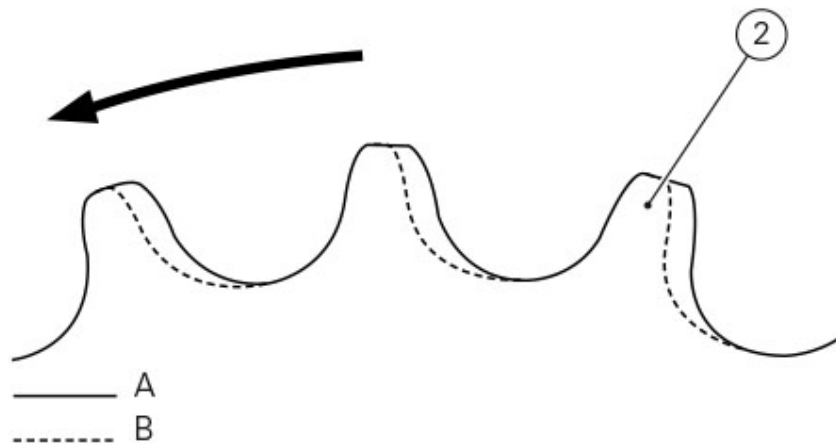
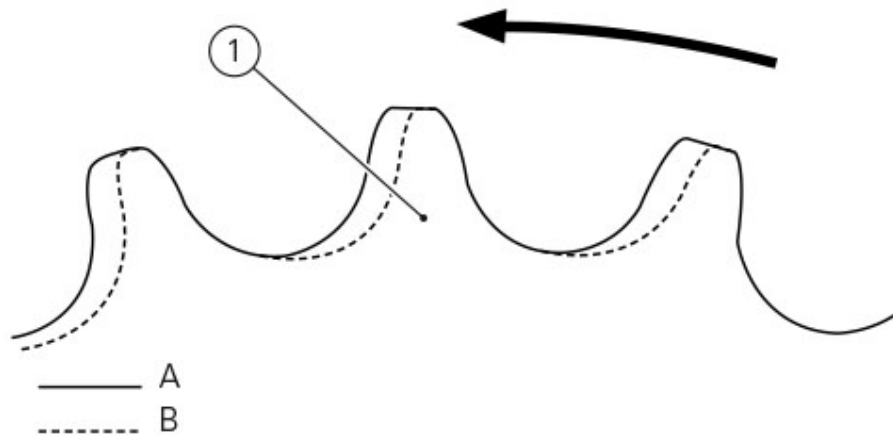

Important

Make sure that the rear sprocket, front sprocket and chain are all replaced together as a set.

Refitting the rear footpegs

Fit spring (17) into rear footpeg (15).

Apply generic grease on the spring end and insert the ball (16).

Position plate (18) so that the two chamfers are facing the rear side.

Press on the plates and insert the plate/footpeg assembly in the footpeg holder.



Smear the recommended grease on pin (13) and insert as shown.

Lock shaft using circlip (12).

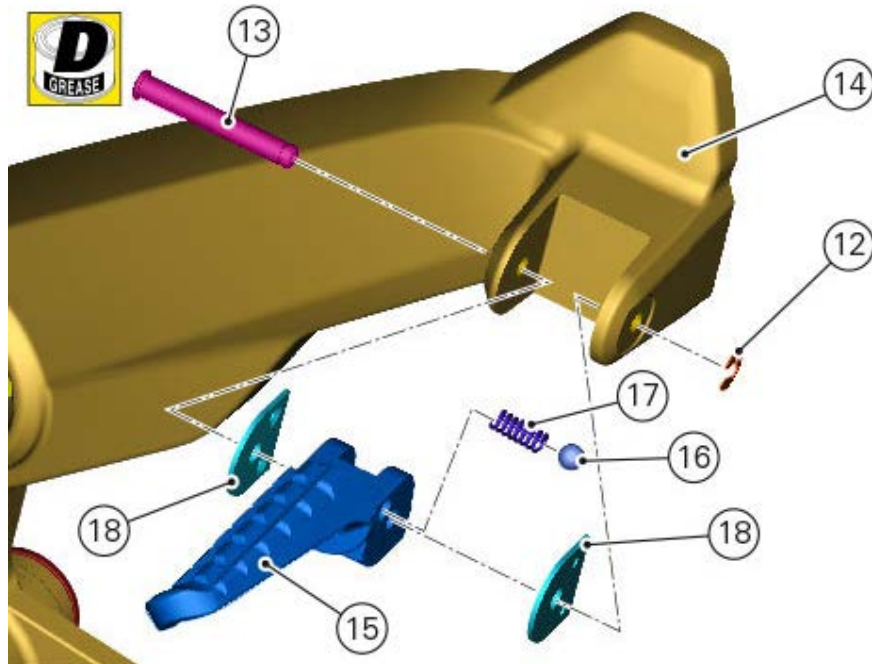

Removing the rear footpegs

The following procedure applies to both rear footpegs.

Remove the snap ring (12) releasing pins (13) and (15) and recovering ball (16), spring (17) and the two plates (18).

Slide off the footpeg (15).

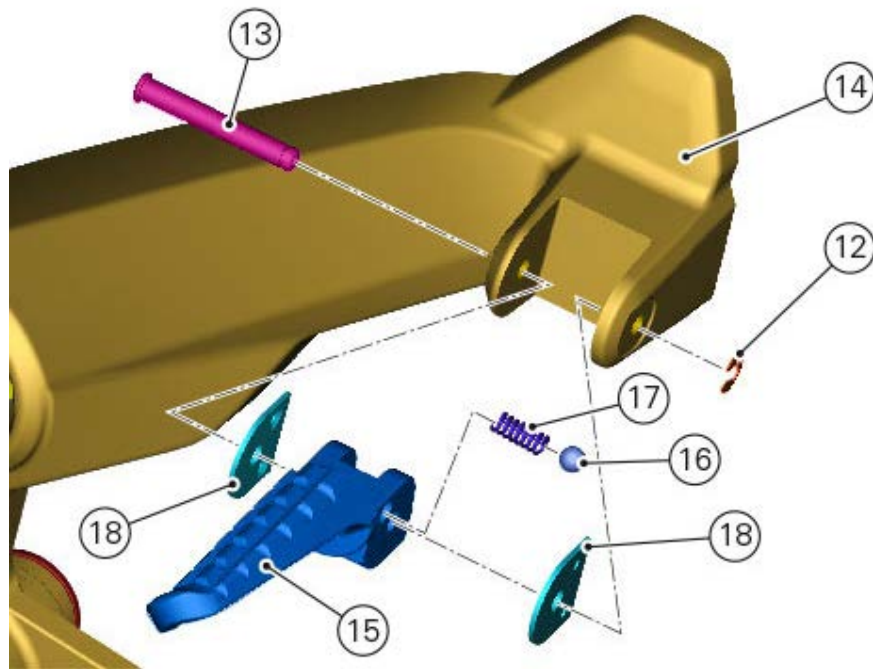

Refitting the front footpeg support

If previously removed, lubricate the two vibration damping pads (19) with specified product and position them as shown in the figure.

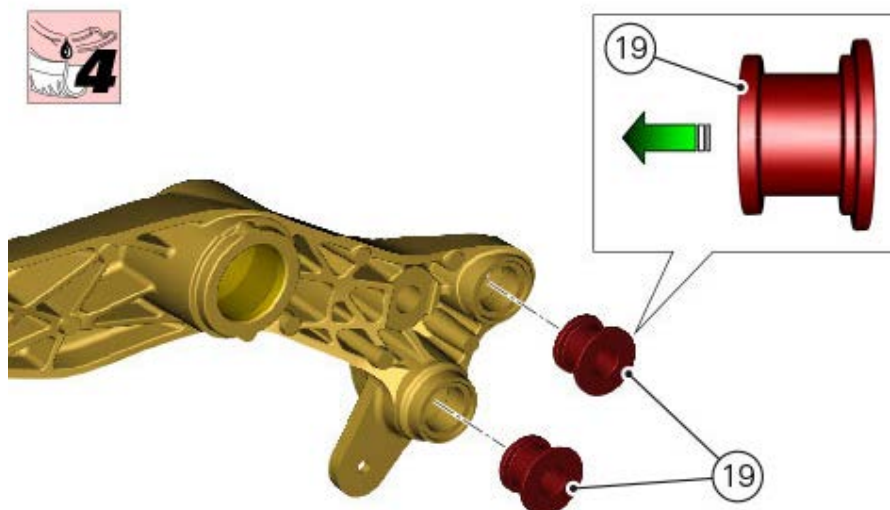

Use a suitable press to fit the silent block (20)

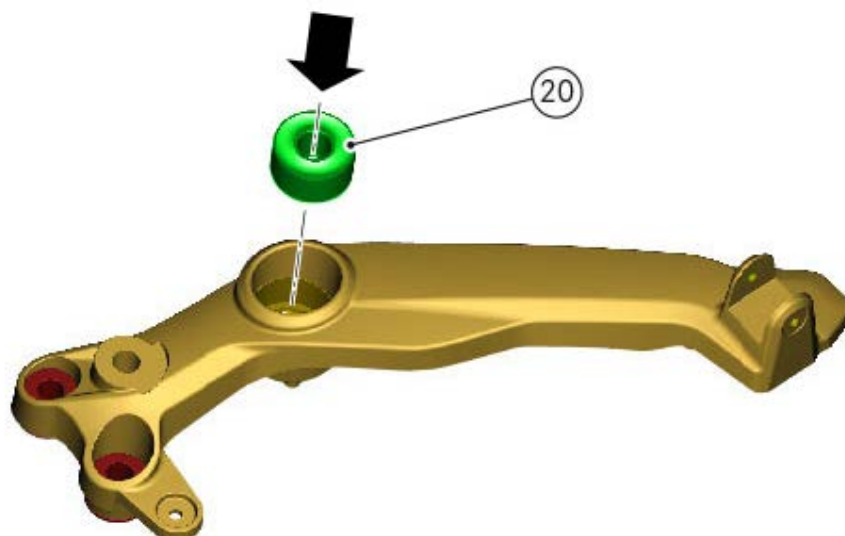

LH footpeg holder

Position the footpeg holder on the frame.
Start the screws (2) and (3) retaining footpeg holder to the frame.
Start screw (4) securing footpeg holder to exhaust.

Tighten the screws (2) to a torque of $36 \text{ Nm} \pm 10\%$.
Tighten the screw (3) to a torque of $55 \text{ Nm} \pm 5\%$.

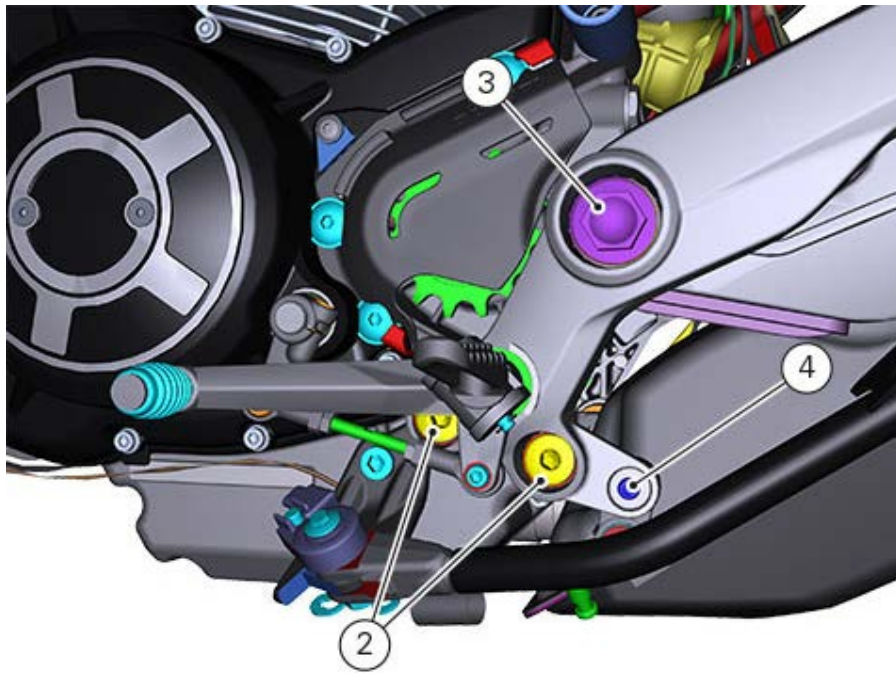

RH footpeg holder

Position the footpeg holder on the frame.
Start the screws (6) and (5) retaining footpeg holder to the frame.

Tighten the screws (6) to a torque of $36 \text{ Nm} \pm 10\%$.
Tighten the screw (5) to a torque of $55 \text{ Nm} \pm 5\%$.

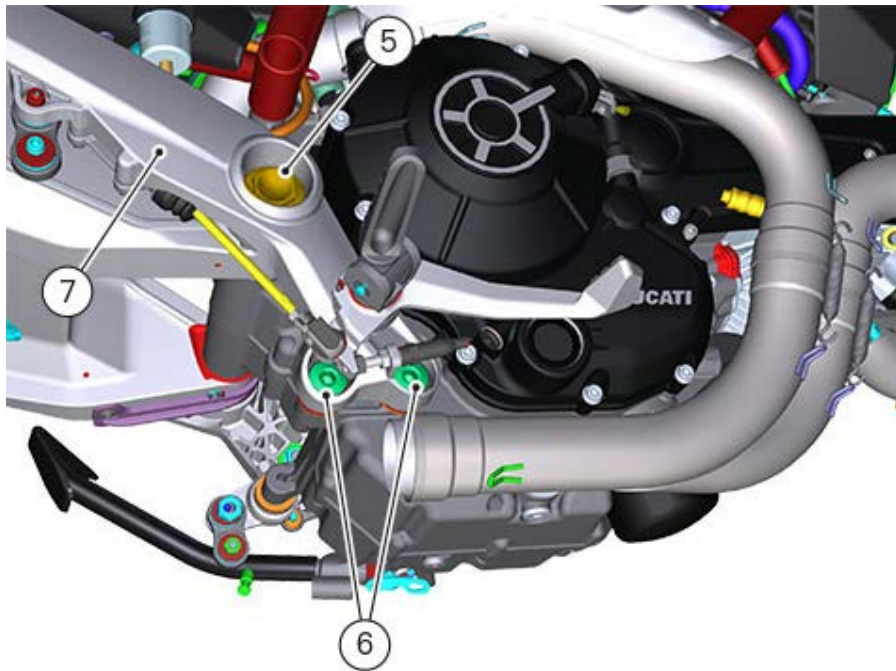

Refit the silencer ([Refitting the silencer](#)).

Removing the front footpeg support

LH footpeg holder

Release the gearbox rod by loosening screw (1).

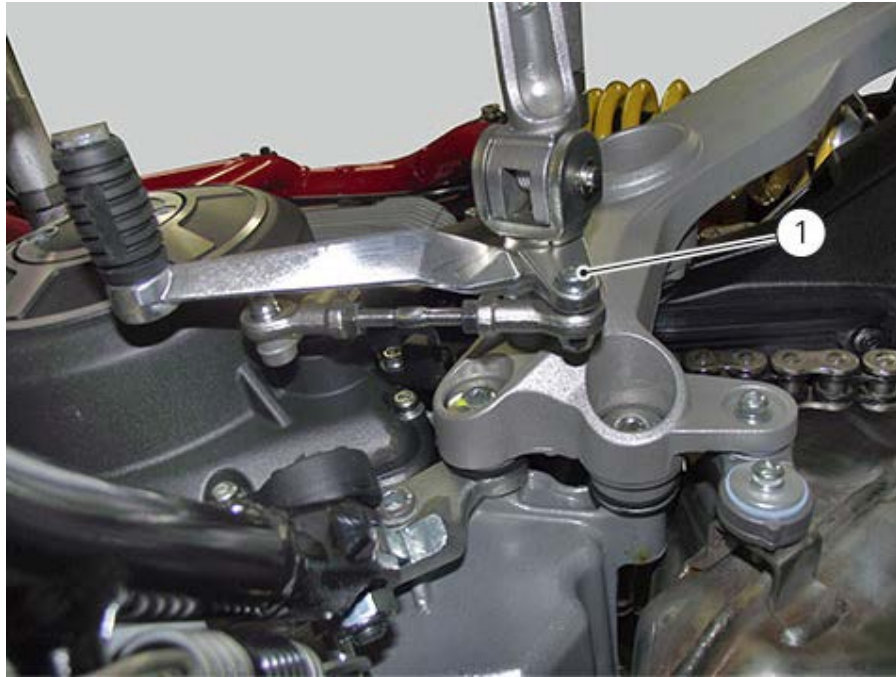

Loosen the screws (2) and (3) retaining footpeg holder to the frame.
Undo screw (4) securing footpeg holder to exhaust.

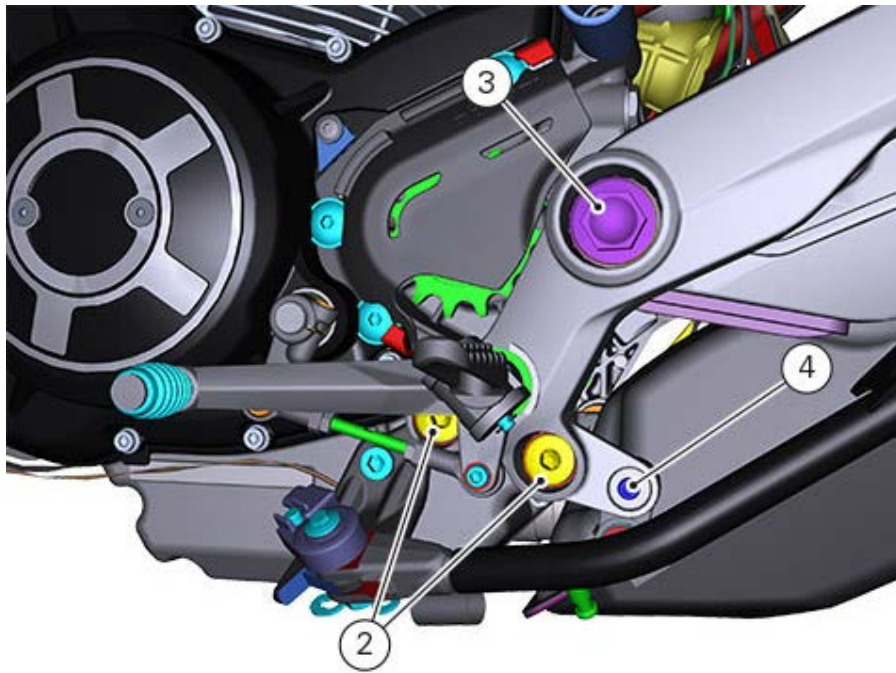

Remove the LH footpeg holder from the frame.

RH footpeg holder

Remove the silencer ([Removing the silencer](#)).

Loosen the screws (5) and (6) retaining footpeg holder to the frame.
Remove footpeg holder (7) by releasing the rear braking system.

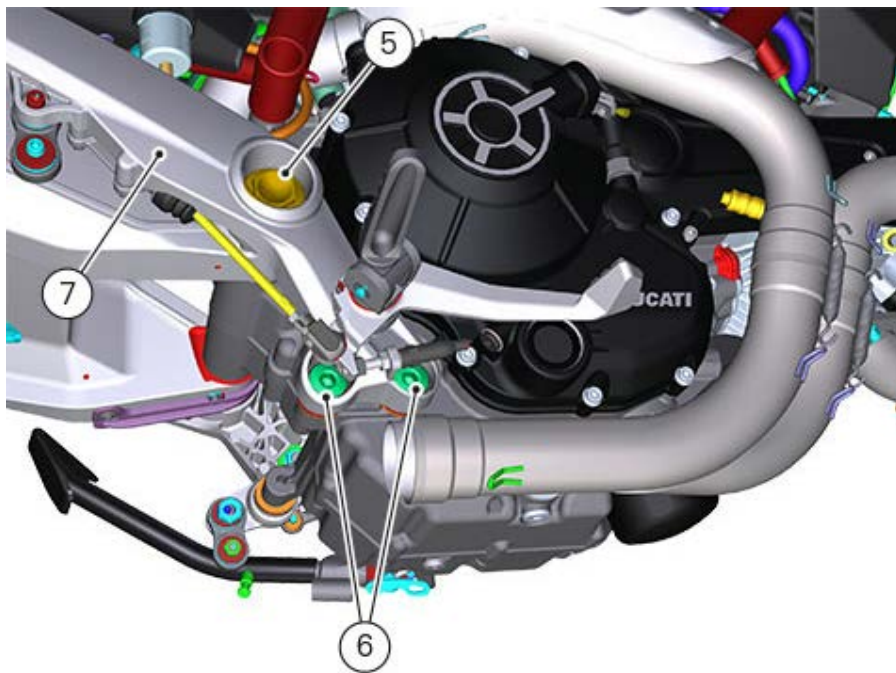

Refitting the front footpegs

Position spring (11) so that it engages in the footpeg holder bracket as shown in the figure.

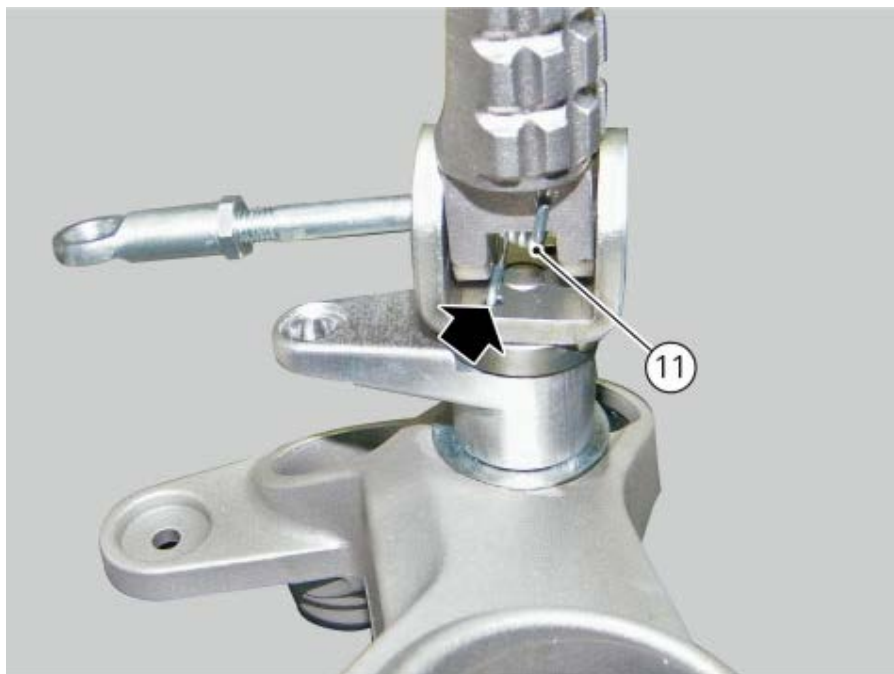

Fit front footpeg (10) in place.
Apply the recommended grease to pin (9).
Fit pin (9) as shown.
Lock shaft using circlip (8).

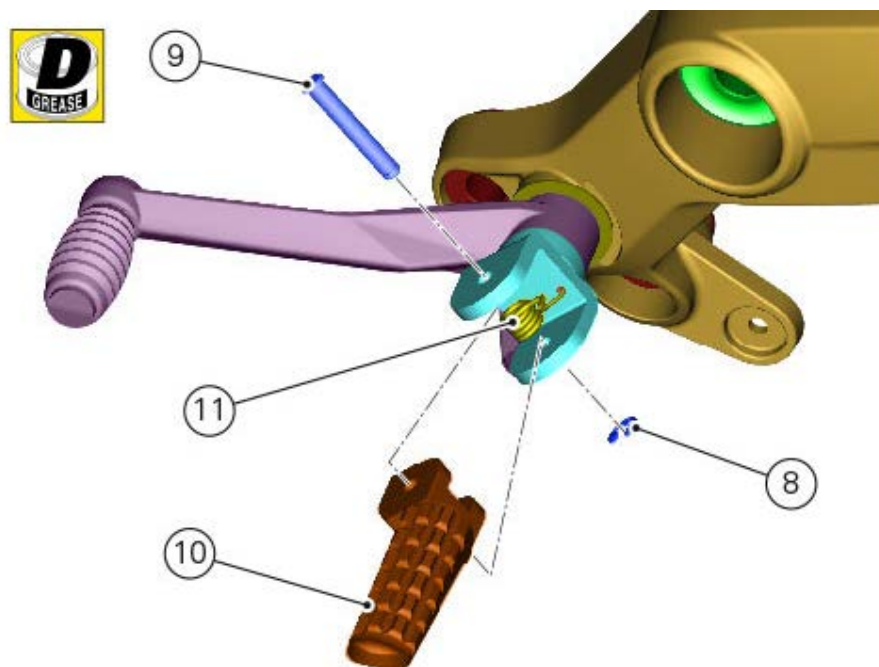

Removing the front footpegs

Remove the footpeg holders ([Removing the front footpeg support](#)).



Remove the circlip (8) thereby releasing the pin (9).
Slide out pin (9), while supporting the footpeg (10).
Slide out footpeg (10) from its seat and collect spring (11).

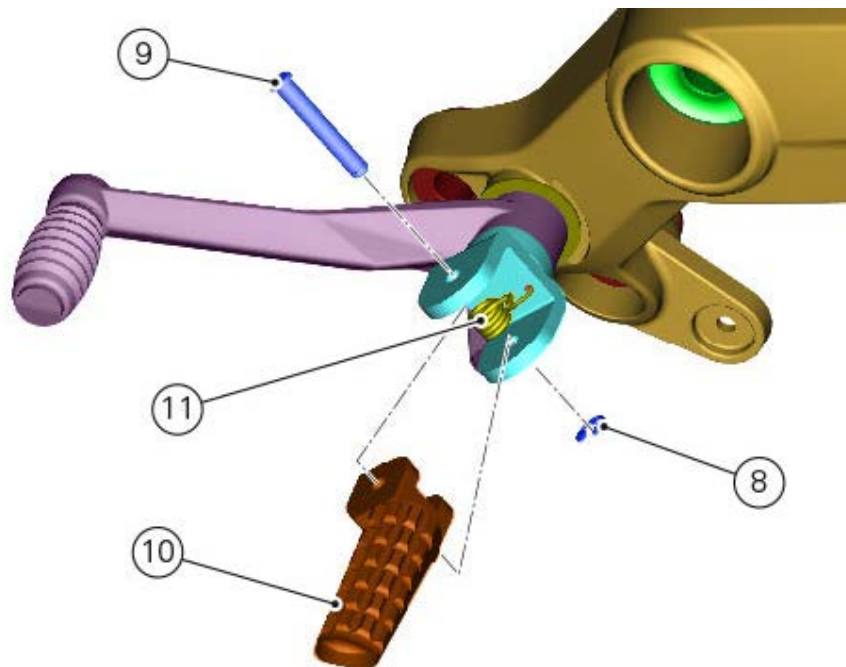

Refitting the side stand

Insert the side stand duly greased with specified product.
Fix with pin (10).
Tighten nut (9) to a torque of $20 \text{ Nm} \pm 10\%$.



Position springs (7) and (8) fixing them in retainers (A) and (B).

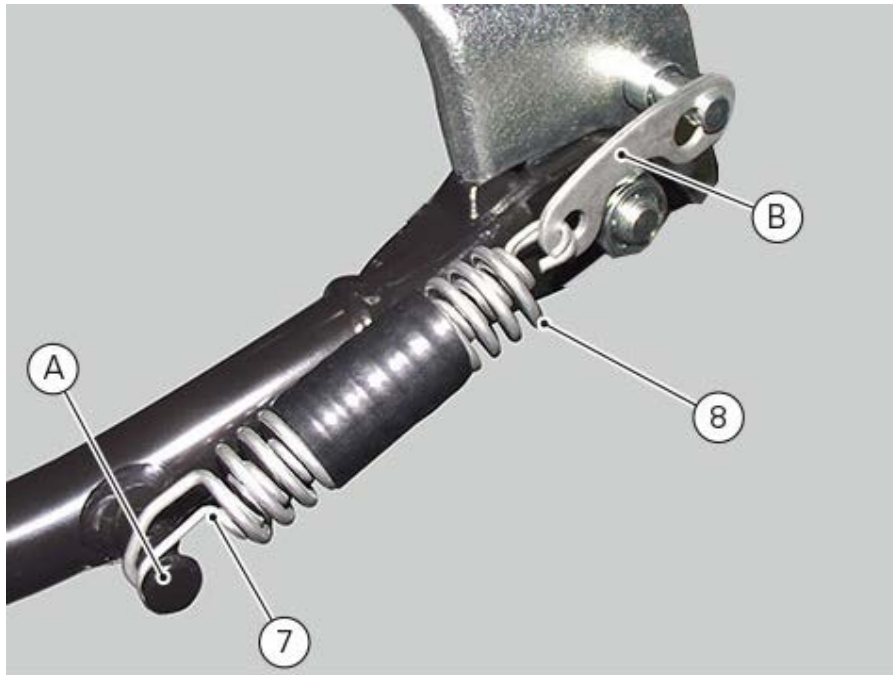

Place sensor (2) on the side stand inserting the sensor pin (C) into the stand hole (D) and aligning the stand pin (E) with the sensor opening (F).

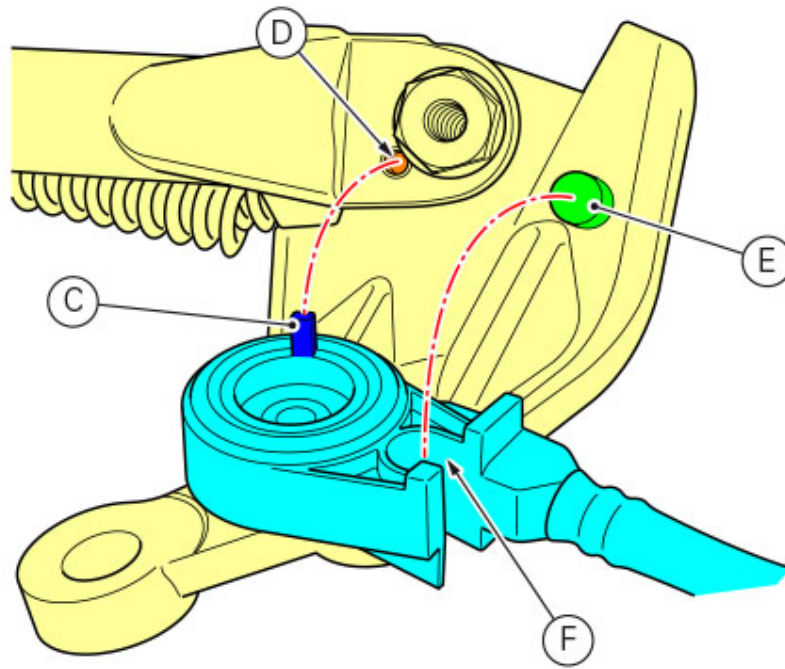

Start and tighten the screw (6) with pre-applied threadlocker to a torque of $5 \text{ Nm} \pm 10\%$.



Place the side stand on the frame, fit screw (3) and tighten it to a torque of $36 \text{ Nm} \pm 10\%$.

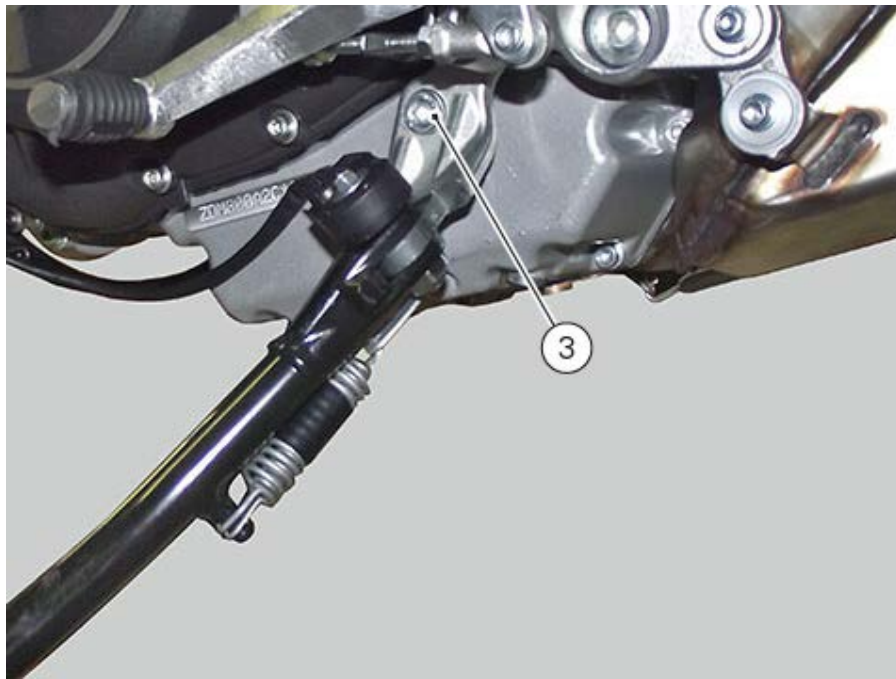

Tighten the screw (4) to a torque of $36 \text{ Nm} \pm 10\%$.

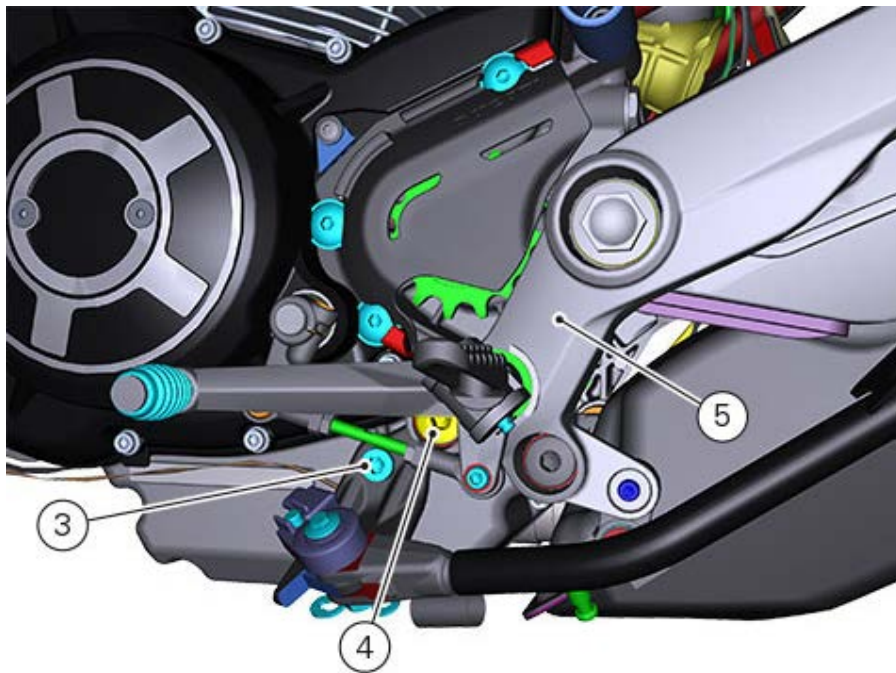

Removing the side stand

Properly support the vehicle.

Disconnect connector (1) of the side stand switch (2) from the main wiring.

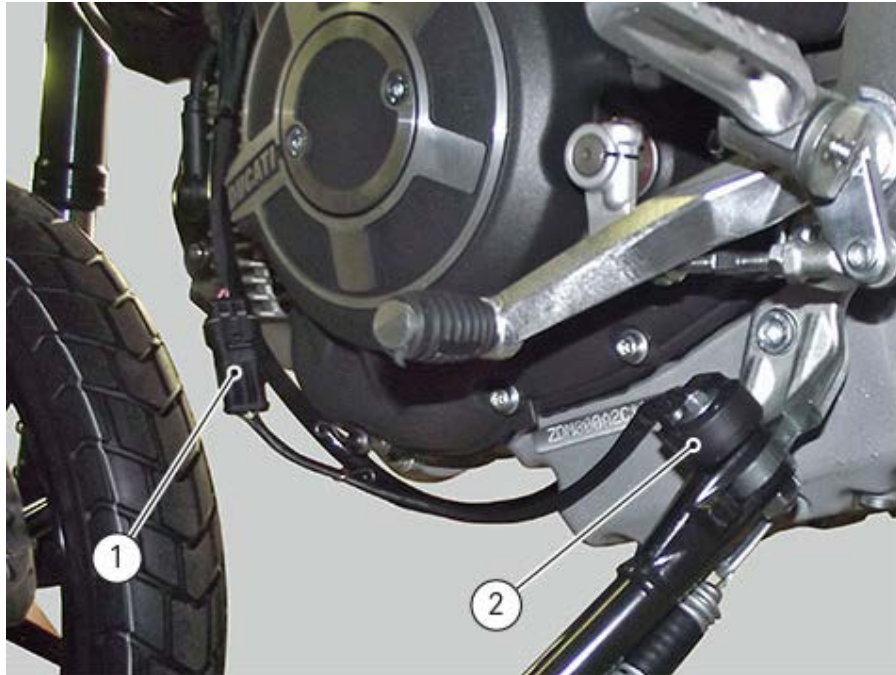

Undo screw (3) securing stand to engine block.

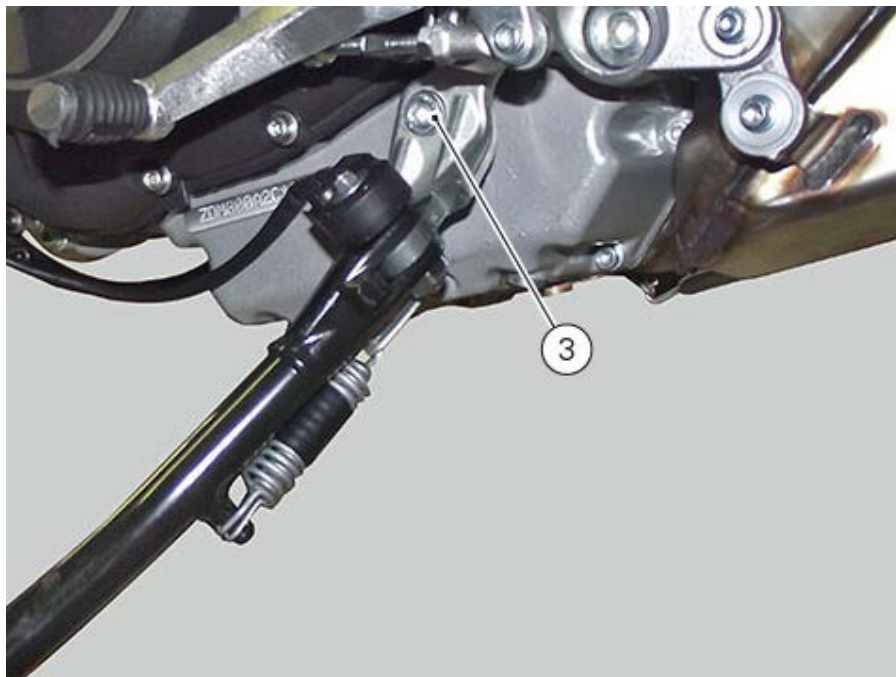

Undo the retaining screw (4) of the footpeg holder plate (5).
Remove the side stand.

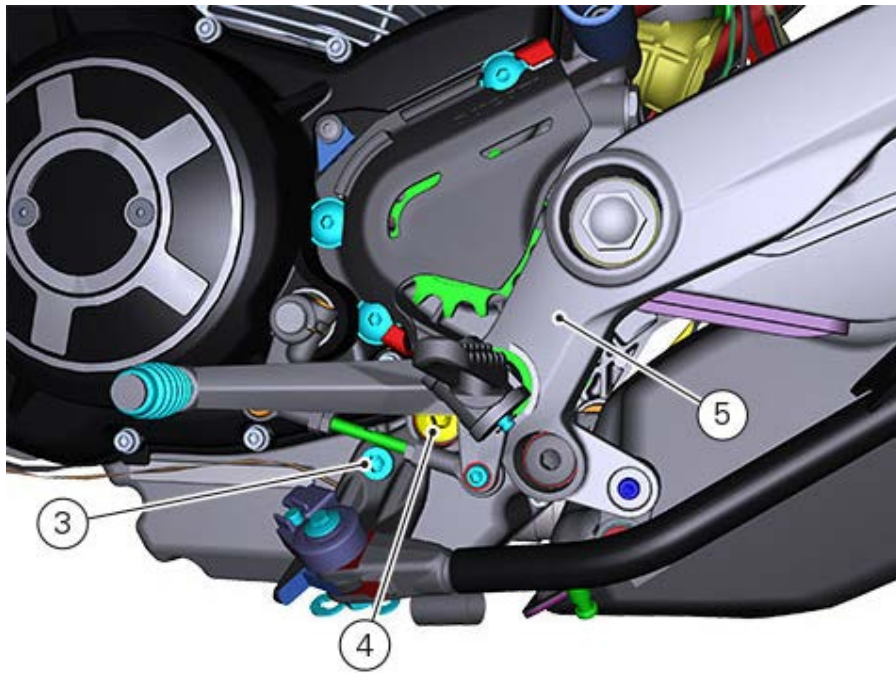

Disassembling the side stand

Loosen screw (6) and remove the switch from the stand.



Release stand return springs (7) and (8) disengaging them from retainers (A) and (B).

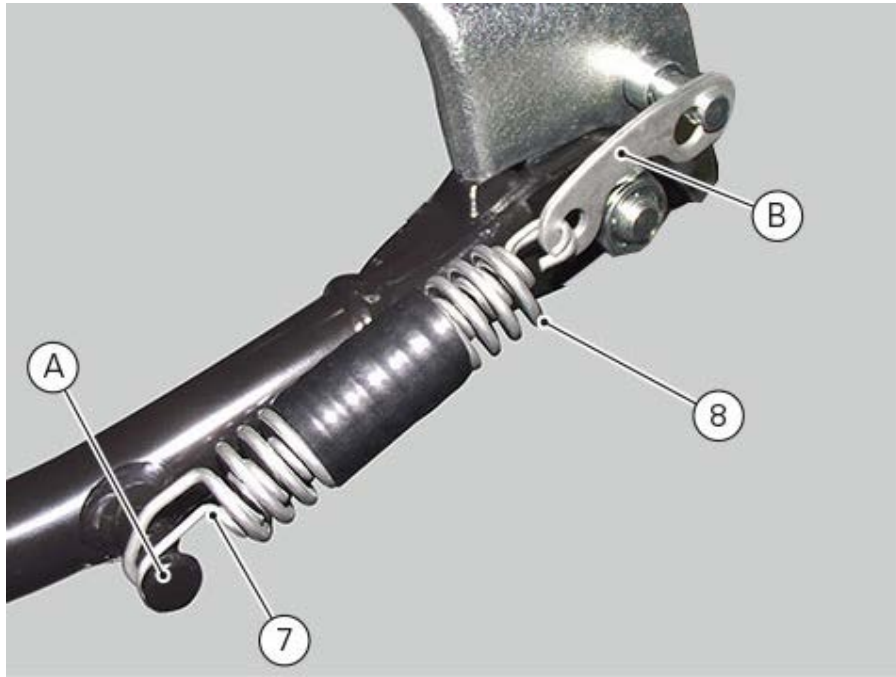

Loosen nut (9) of pin (10) retaining stand to plate.

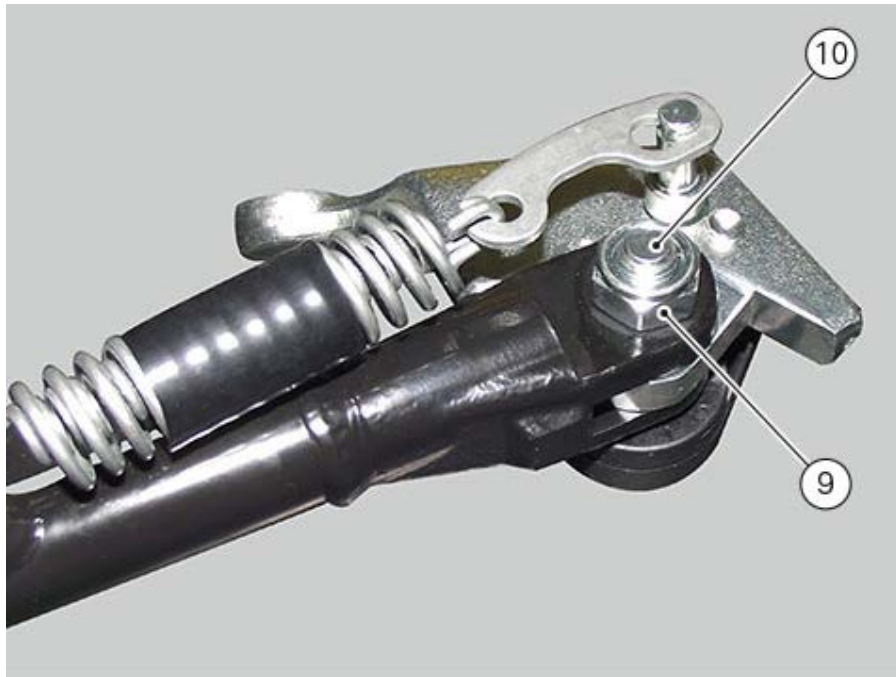

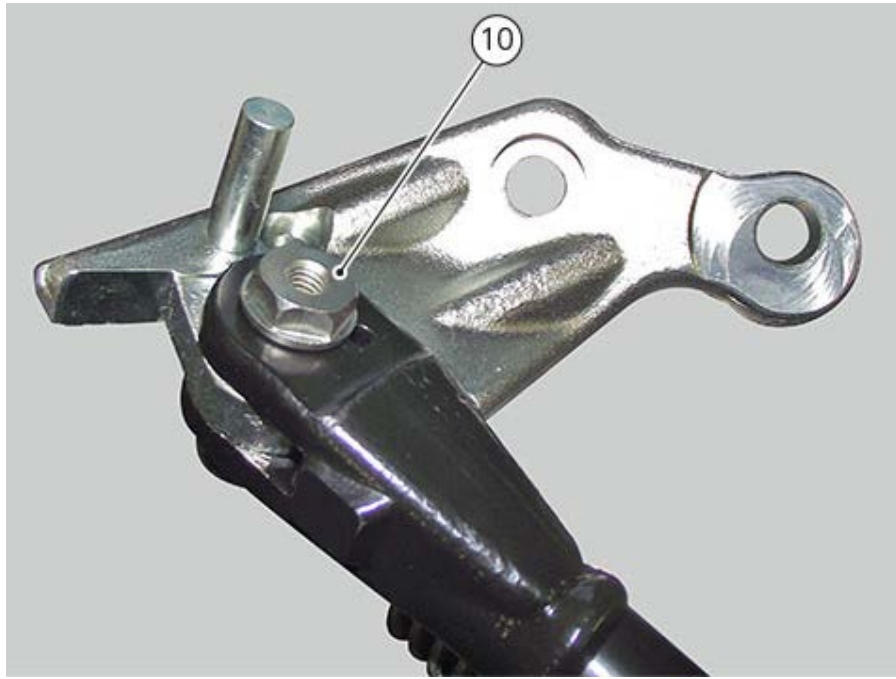

Checking the frame

Compare the dimensions of the frame with the values indicated here to determine whether it needs to be re-aligned or replaced.

Important

Damaged frames must be changed, not repaired. Any work carried out on the frame can give rise to potential danger, infringing the requirements of EC directives concerning manufacturer's liability and general product safety.

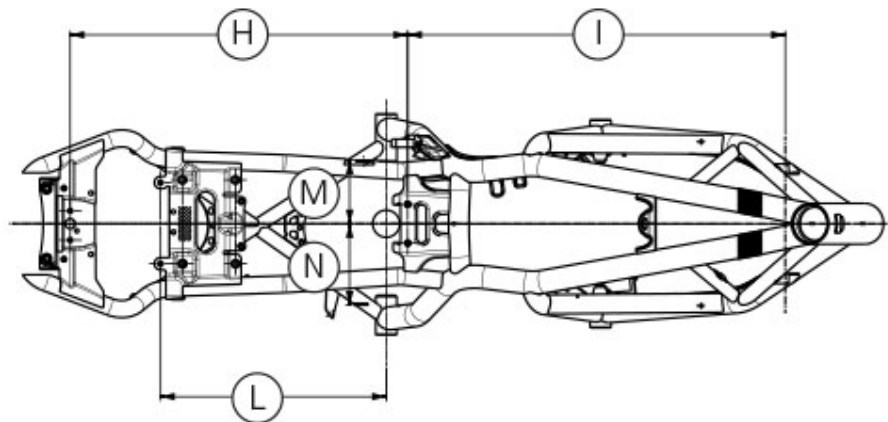
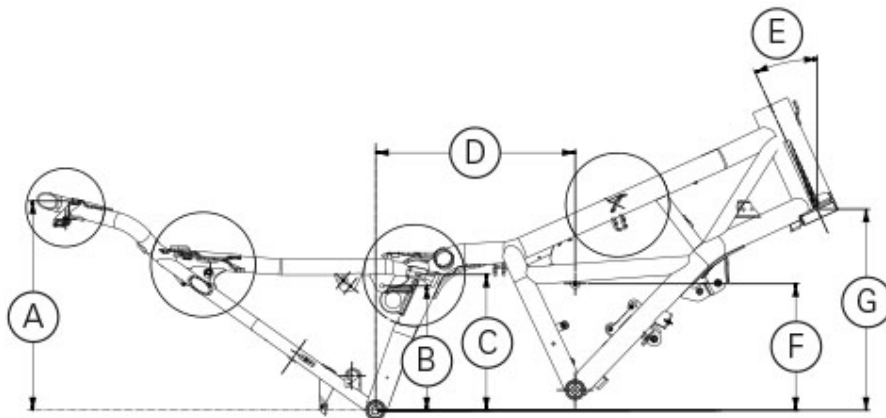

A=330.3 mm
B=196.4 mm
C=214.4 mm
D=315.2 mm
E= 24.4°
F=199.6 mm
G=317.6 mm
H=495.9 mm
I=555 mm

L=331.7 mm

Refitting the structural parts on frame

Make sure that the two outer rings (1) in the steering tube (2) are fitted.

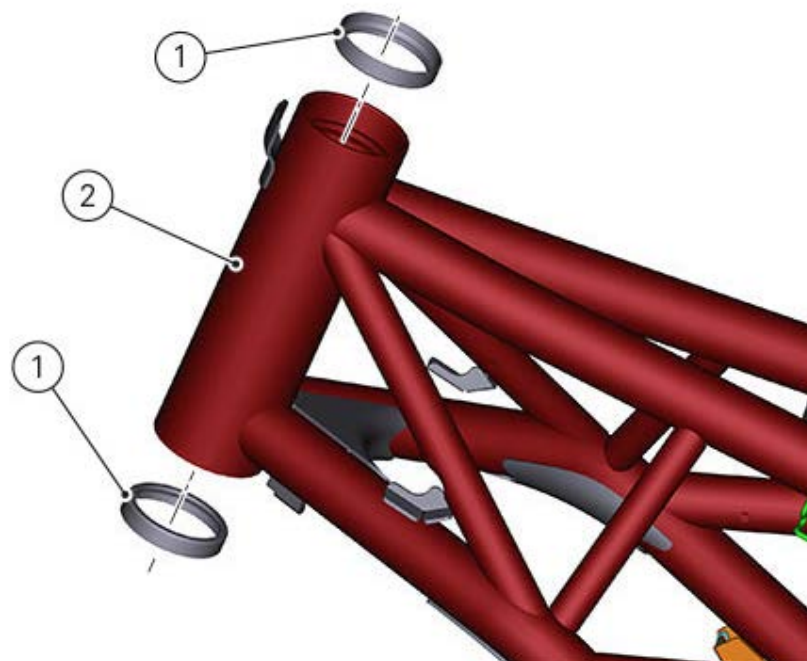

Make sure that the vibration damping pads (3) are fitted.



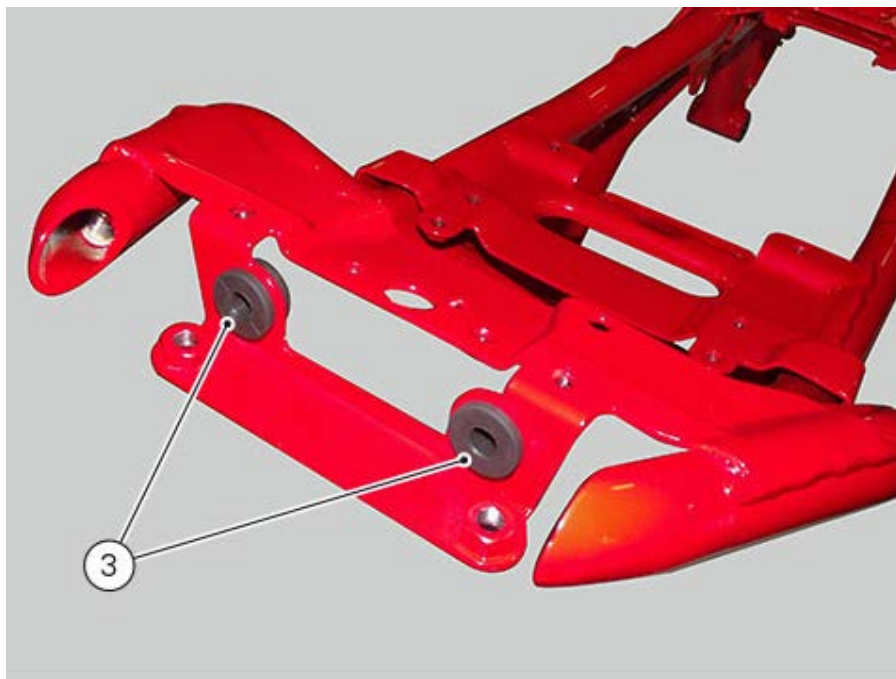
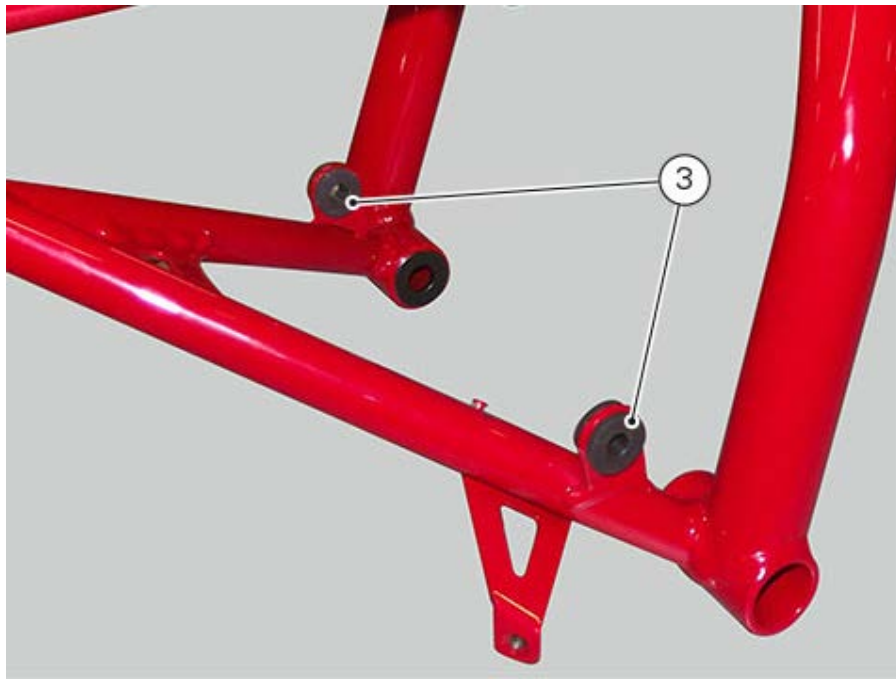

Make sure clips (4) are in place.

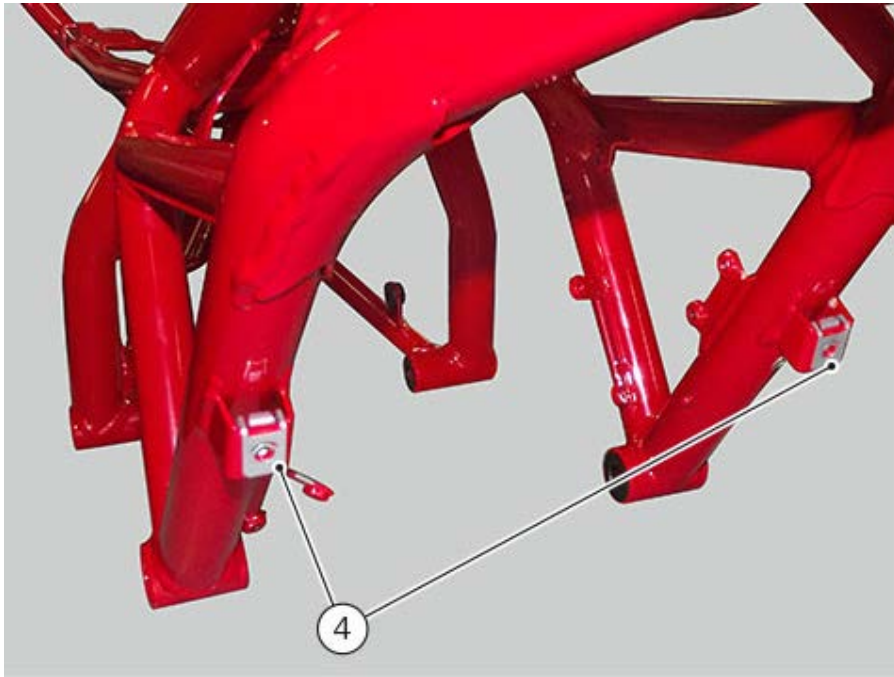

Make sure clips (5) are in place.

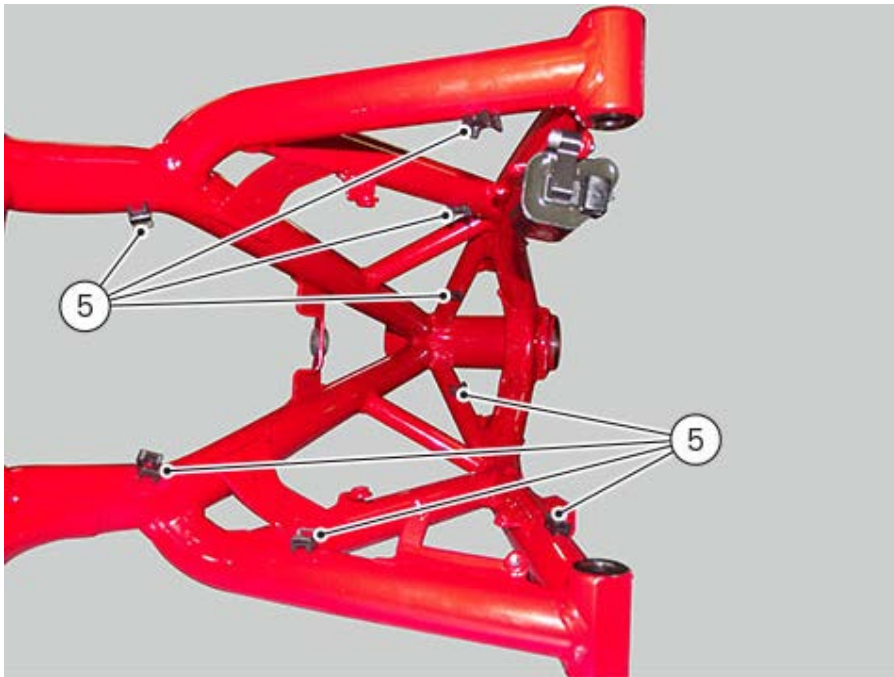

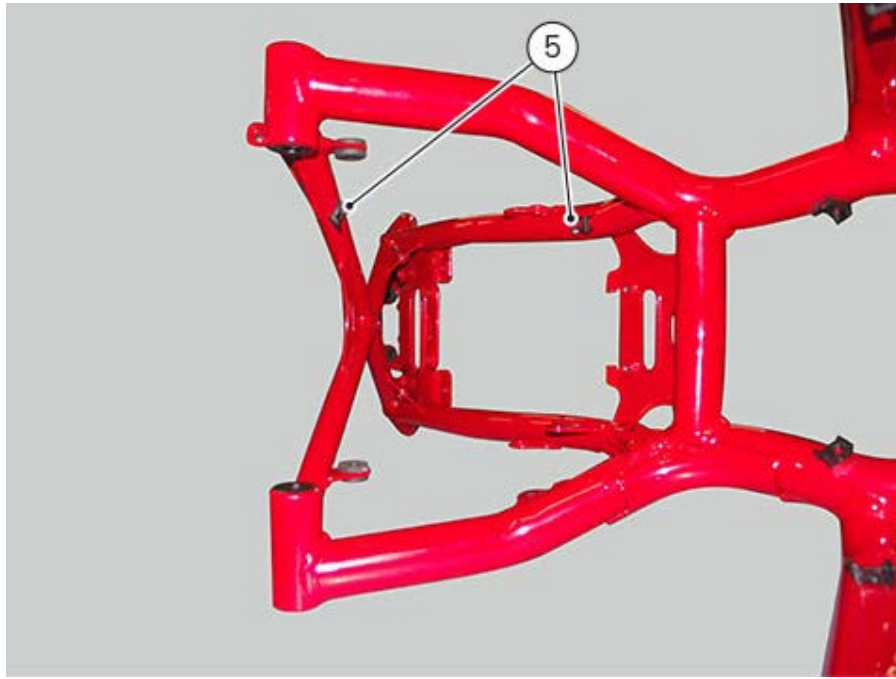

Removing structural components and frame

Before carrying out dimensional checks on the frame, remove all the fitted superstructures, referring to the removal procedures outlined in the relevant sections of this manual.

The list below indicates the components to be removed in a logical order.

Remove the seat ([Removing the seat](#)).

Remove the fuel tank ([Removing the fuel tank](#)).

Remove the air filter ([Removing the air filters](#)).

Remove the throttle control cable ([Removing the throttle control](#)).

Remove the airbox ([Removing the airbox](#)).

Remove the throttle body, the blow by and the oil breather pipe ([Removing the throttle body](#)).

Remove the secondary air system pipes and valve ([Removing the secondary air system](#)).

Remove the supply system and the injectors from the intake manifolds ([Removing the throttle body](#)).

Disconnect the spark plug caps.

Remove the exhaust system ([Removing the exhaust system](#)).

Drain the lubrication system ([Changing the engine oil and filter cartridge](#)).

Disconnect the starter motor/solenoid starter cable.

Remove the gear shift ([Removing the gear shift](#)).

Remove the front sprocket ([Removing the front sprocket](#)).

Remove the side stand ([Removing the side stand](#)).

Disconnect the wiring connectors on the engine block (Routing of wiring on frame).

Remove the engine block from frame.

Refitting the tail light

Position tail light (3) so that stud bolts (A) are in their seats (B) on the frame.

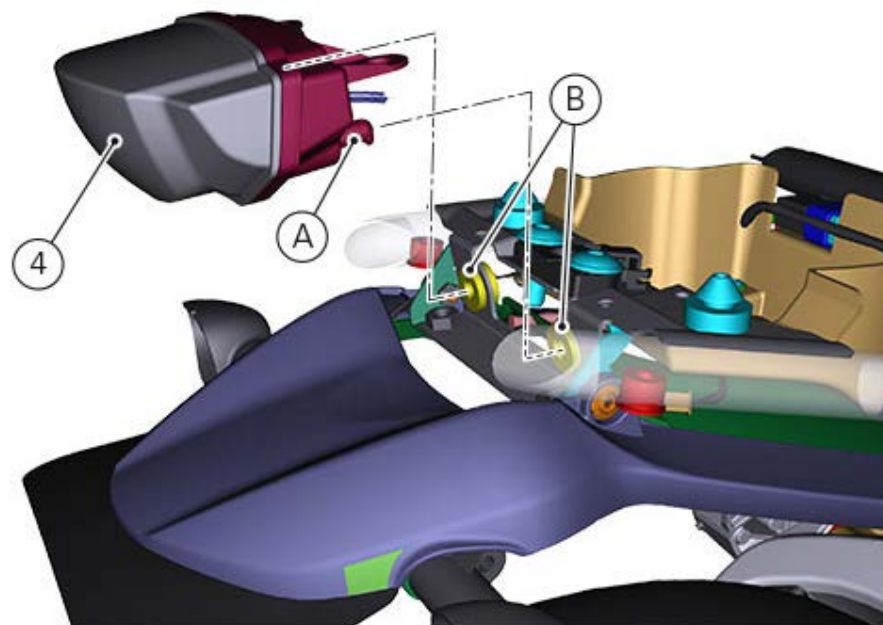

Tighten the two screws (3) to a torque of $5 \text{ Nm} \pm 10\%$.

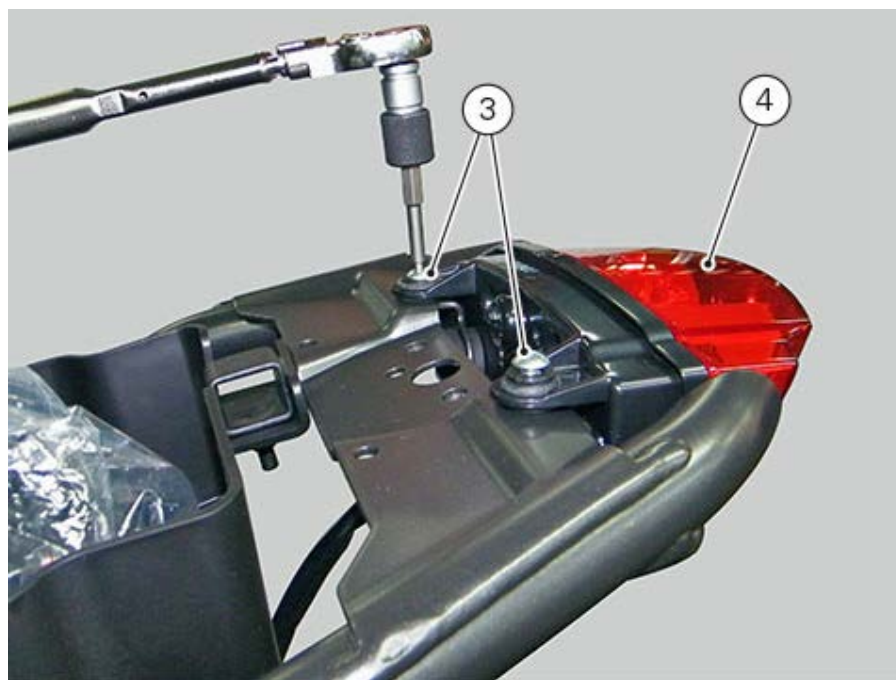

Connect connector (2) and position it by means of two ties (1) as shown in the figure.

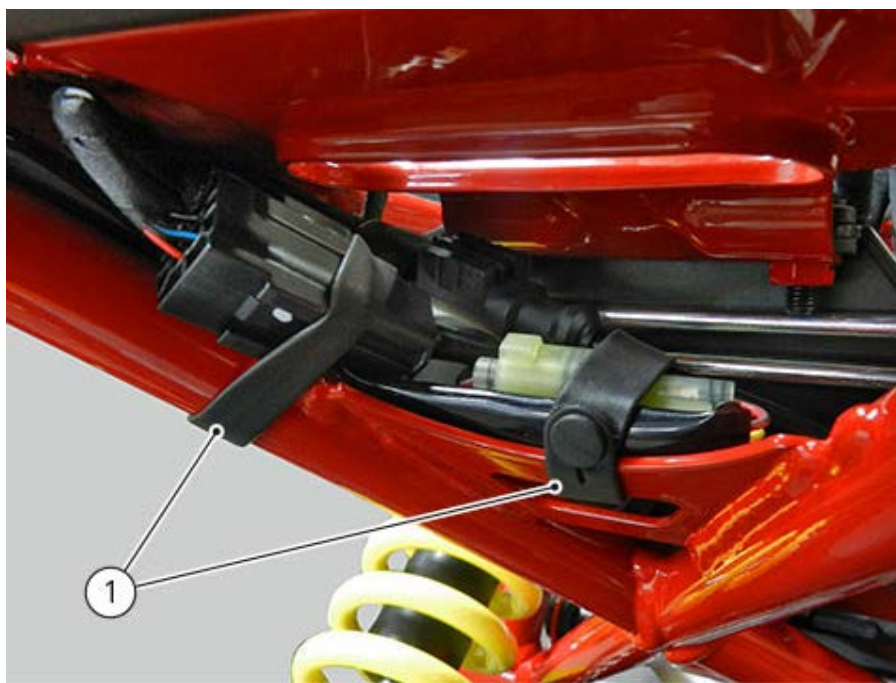
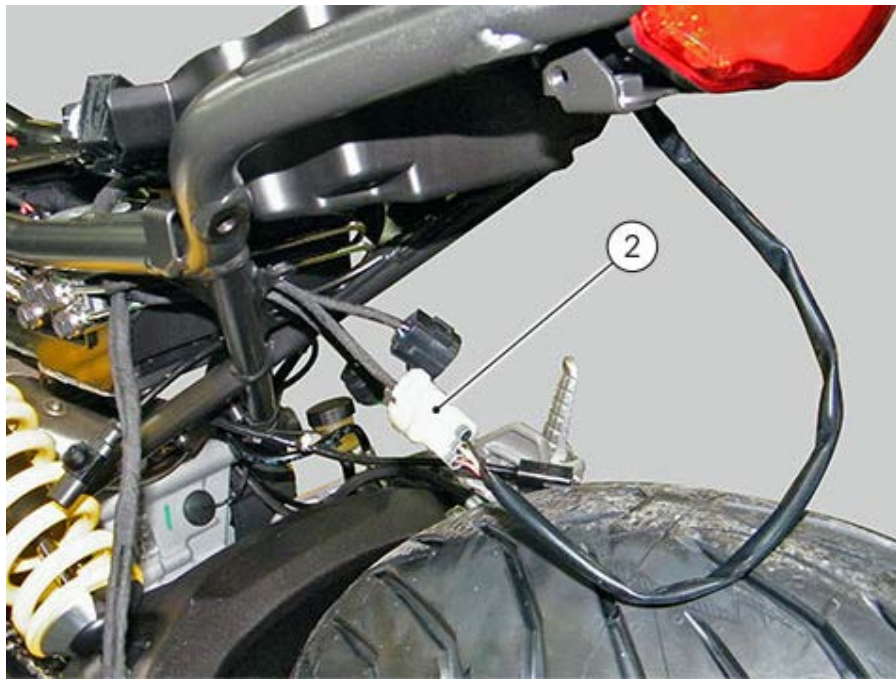

Refit the tail guard ([Refitting the tail guard](#)).
Refit the seat ([Refitting the seat](#)).

Removing the tail light

Remove the seat ([Removing the seat](#)).

Remove the tail guard ([Removing the tail guard](#)).

Release the cables from the ties (1).

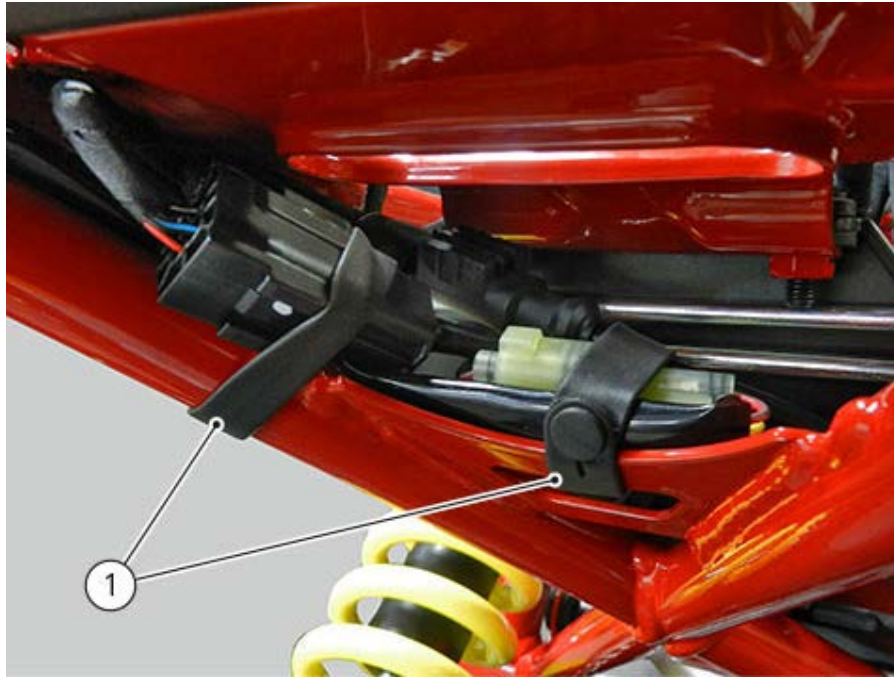

Disconnect tail light connector (2) from main wiring.

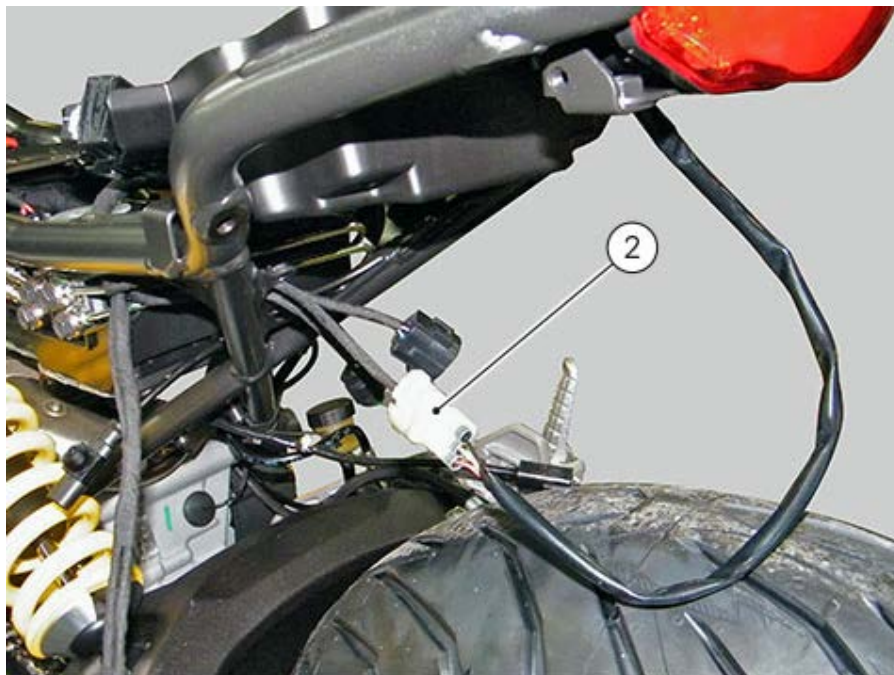

Loosen the two retaining screws (3) and remove the tail light (4).

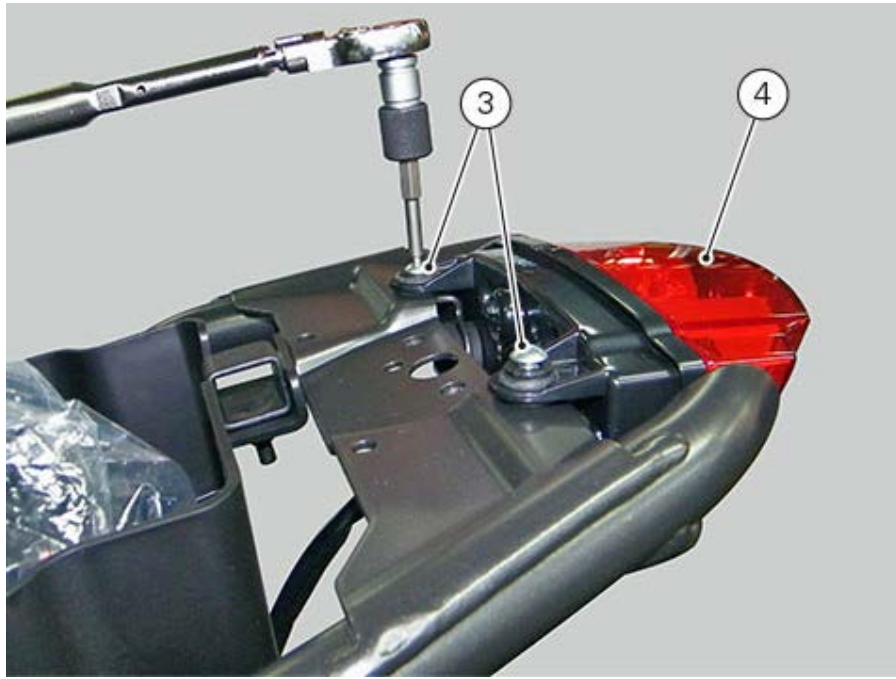

Refitting the number plate holder

If support (9) has been previously removed, proceed as follows:

Apply the indicated threadlocker on the two screws (8).

Fit support (9) on swinging arm (10) by starting it by hand without tightening to torque.

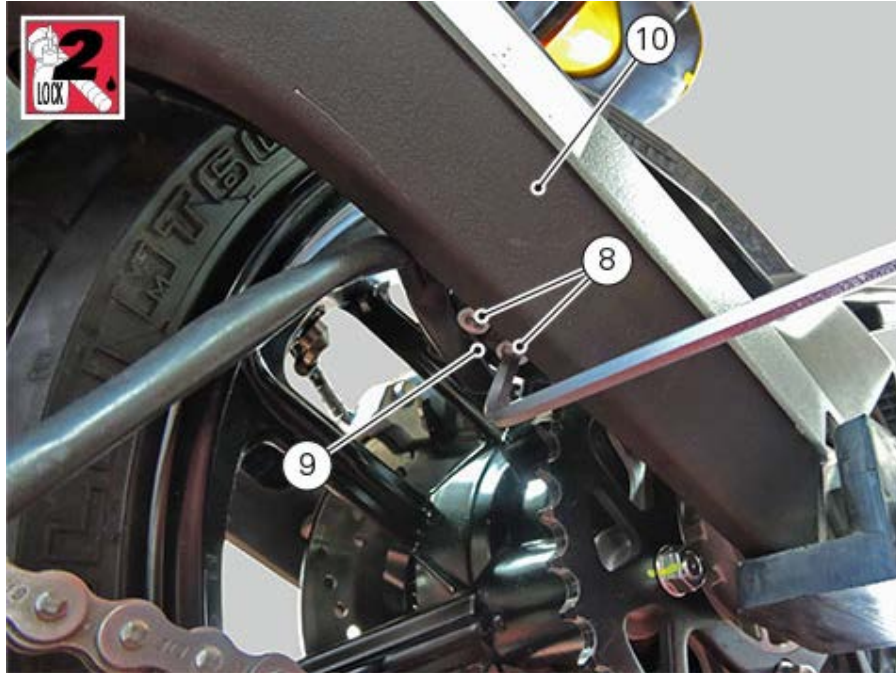

Fix number plate holder plate (15) by tightening screws (14) to a torque of $5 \text{ Nm} \pm 10\%$.



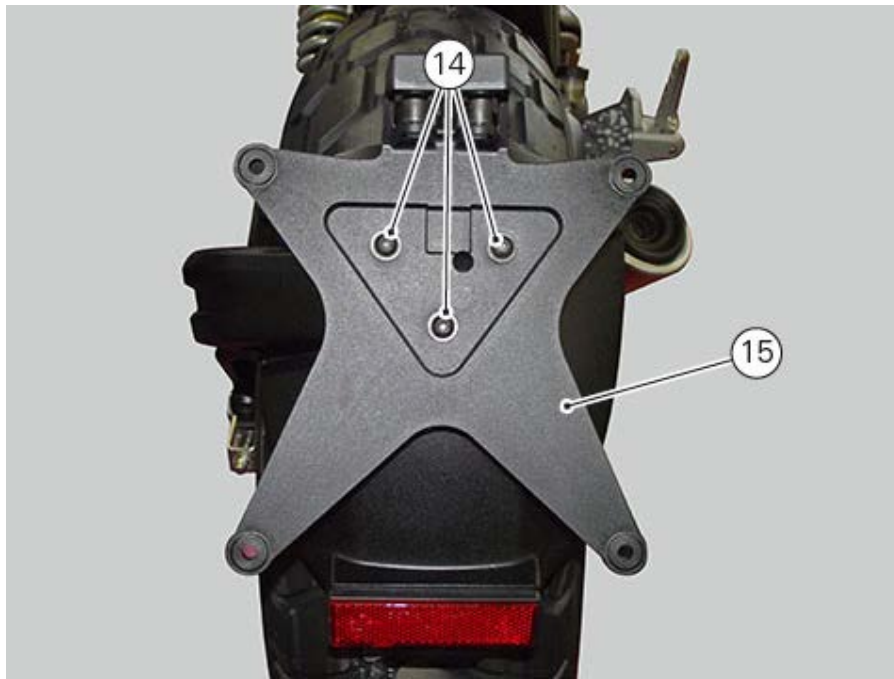

Route the number plate light wiring in the number plate holder subframe.
Tighten the three screws (13) with relevant cable plate to a torque of $2 \text{ Nm} \pm 10\%$.

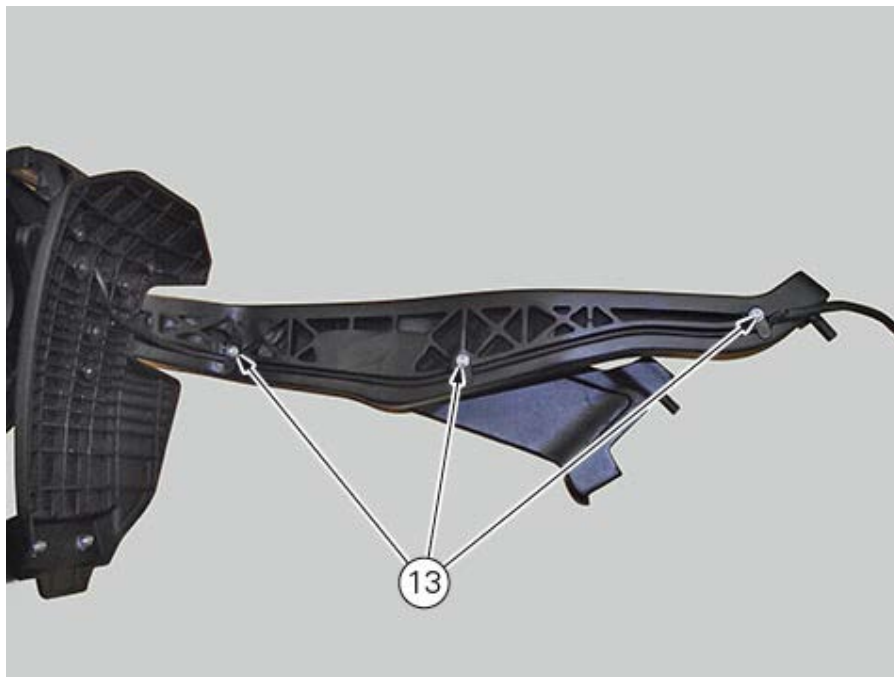

Important

Thoroughly remove the threadlocker from the swinging arm threads and the subframe/number plate holder mating surfaces.

Apply the specified threadlocker to screws (11) and (18).

(11) TCEIF M8X35 screw

(18) TCEIF M8X35 screw

Insert screw (18) with elastic washer (E) and short washer (D) from the outside of the number plate holder subframe.

Insert bushing (F) from inside the frame.

Insert screw (11) with elastic washer (E) and long washer (C) from the outside of the number plate holder subframe.

Insert bushing (F) from inside the frame.

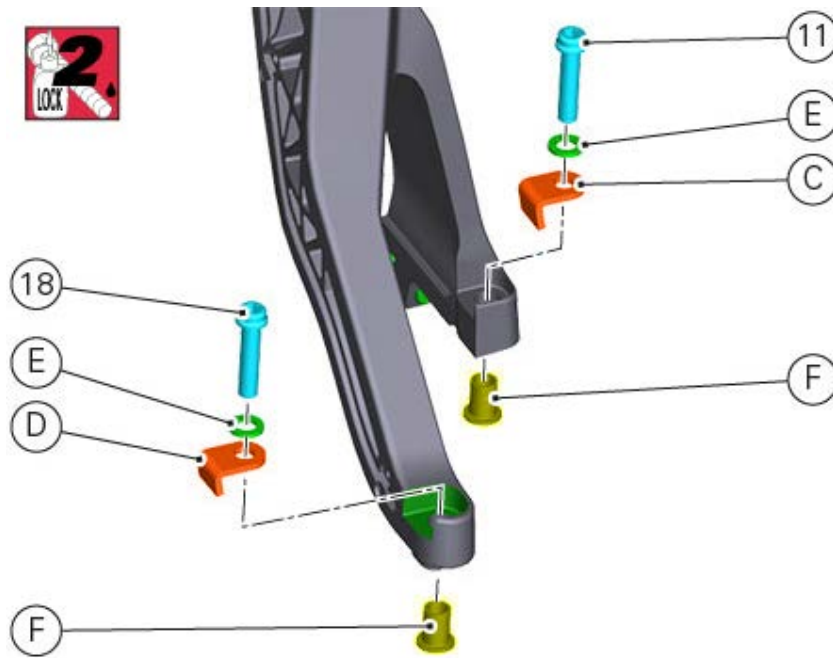

Apply the recommended threadlocker to screw (12).
 (12) TCEIF M6X45 screw

Insert screw (12) with elastic washer (G) and washer (H) from the outside of the number plate holder.
 Insert bushing (I) from inside the number plate holder.

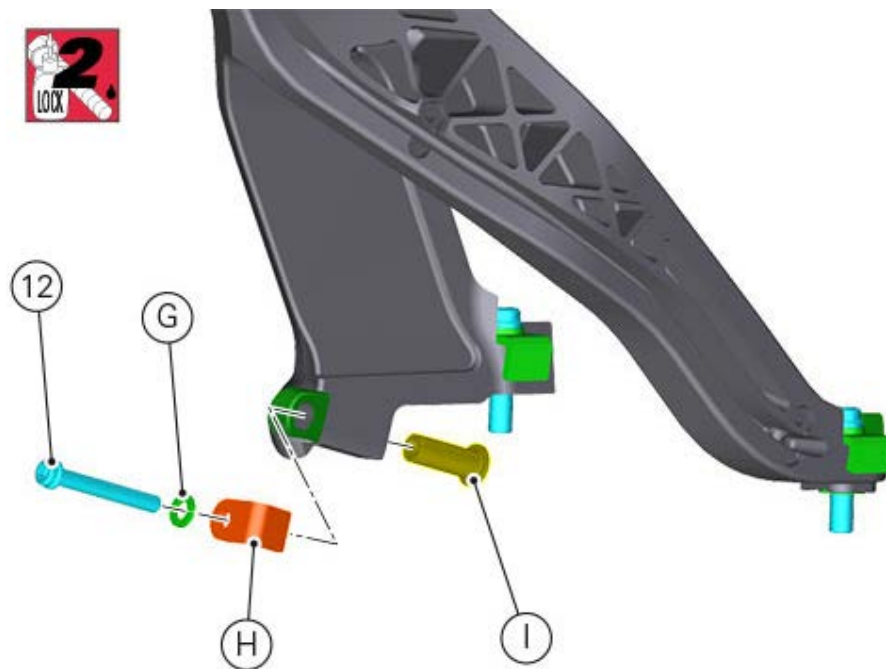

Position the number plate holder subframe on the swinging arm by starting the screw by hand without tightening to torque.

Tighten the screws in the indicated sequence below.

- Tighten the two screws (8) to a torque of $25 \text{ Nm} \pm 10\%$.
- Tighten the screw (12) to a torque of $18 \text{ Nm} \pm 10\%$.
- Tighten the screw (11) to a torque of $30 \text{ Nm} \pm 10\%$.
- Tighten the screw (18) to a torque of $30 \text{ Nm} \pm 10\%$.
- Tighten all five screws again following the sequence above.

Fit screws (5) with cable ring and tighten them to a torque of $1.5 \text{ Nm} \pm 10\%$.
 Reposition the self-locking tie (7).

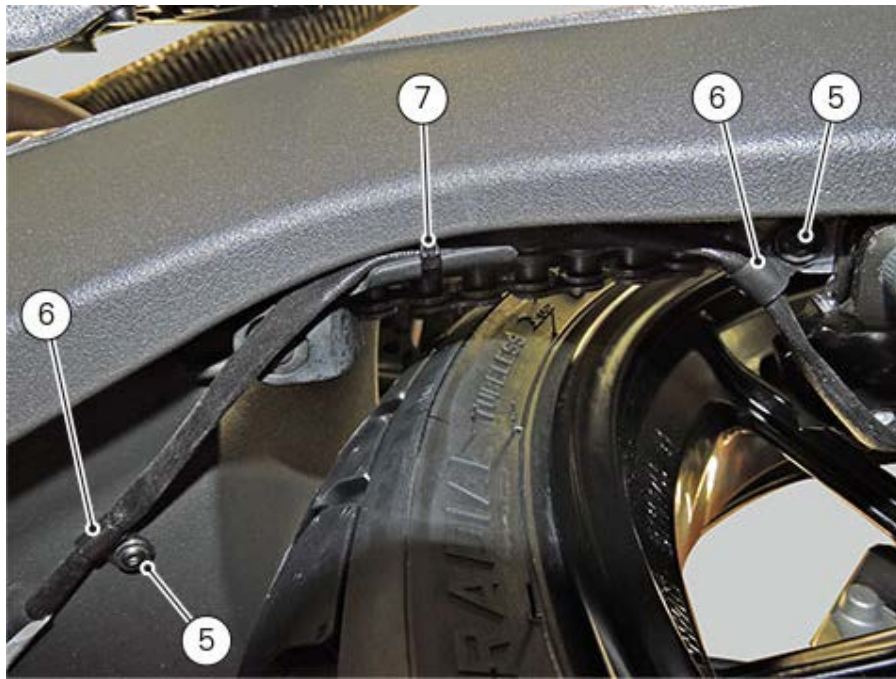

Connect the connector (4).

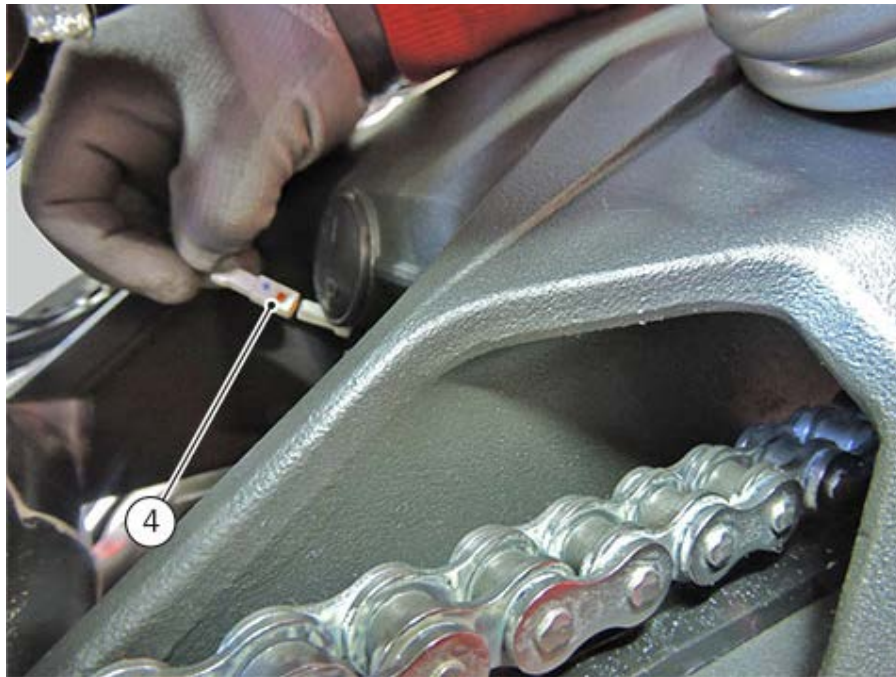

Position the chain guard.

Insert screw (3).

Fit bushing (2) with the relevant screw (1) and tighten screws (1) and (3) to a torque of $5 \text{ Nm} \pm 10\%$.

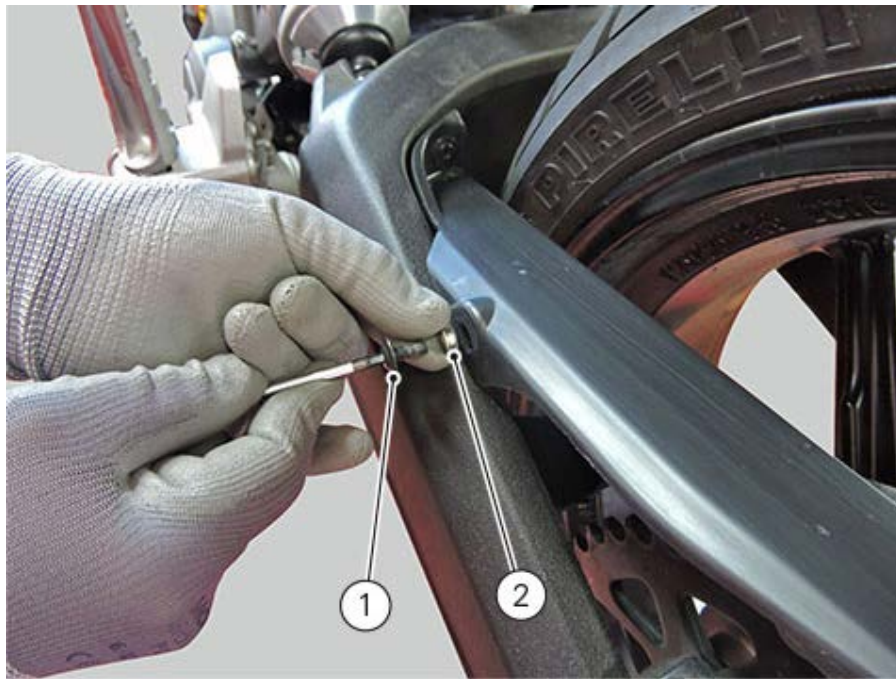

Removing the number plate holder



Note

This procedure is valid for all customisations except the CLASSIC one.

To make the number plate holder removal easier, we recommend removing also the chain guard. Remove screw (1) and the relevant bushing (2).

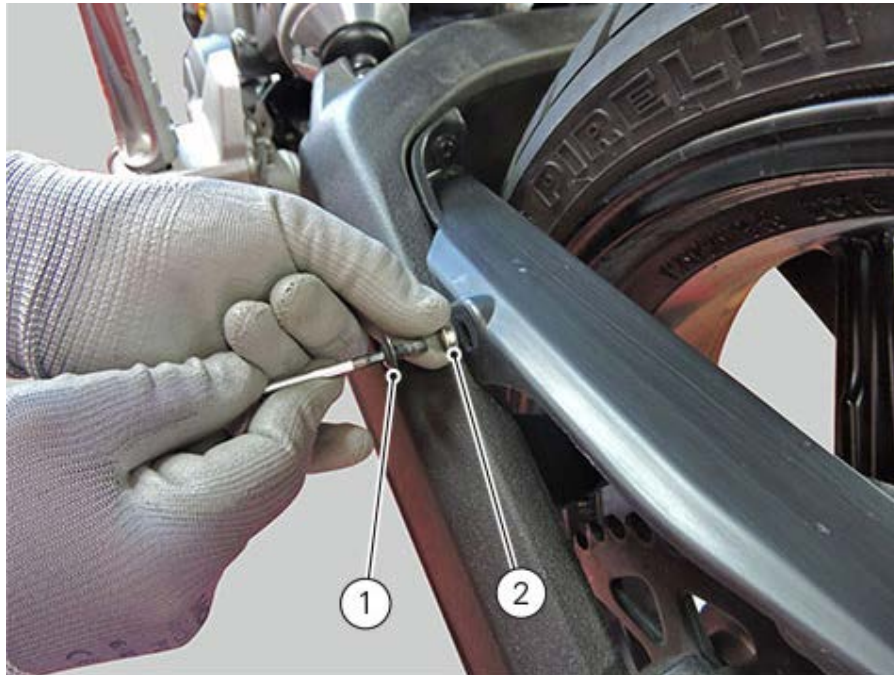

Remove screw (3).



Disconnect the connector (4).

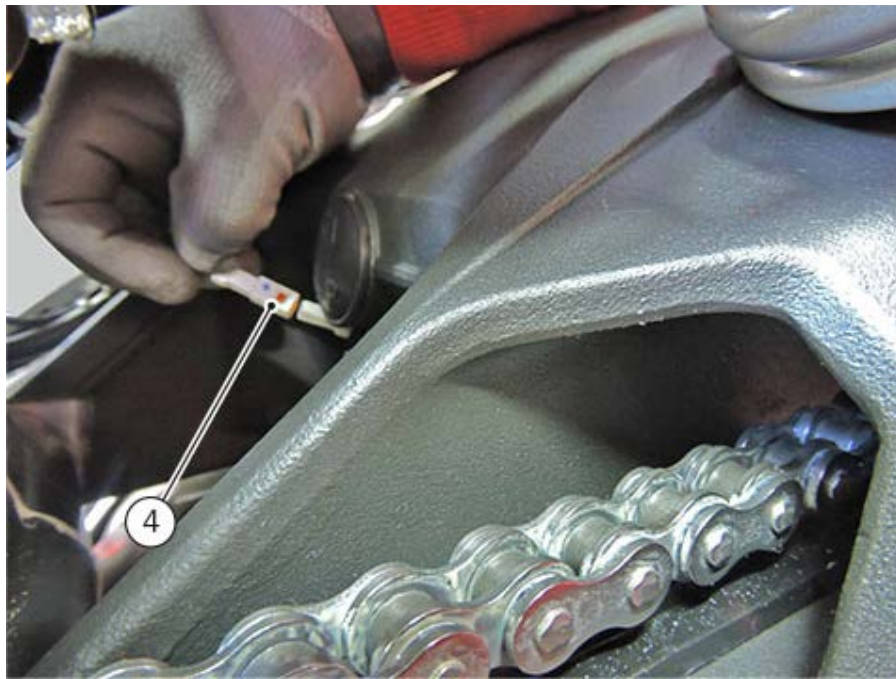

Loosen screws (5) of cable rings (6).
Remove clamp (7).

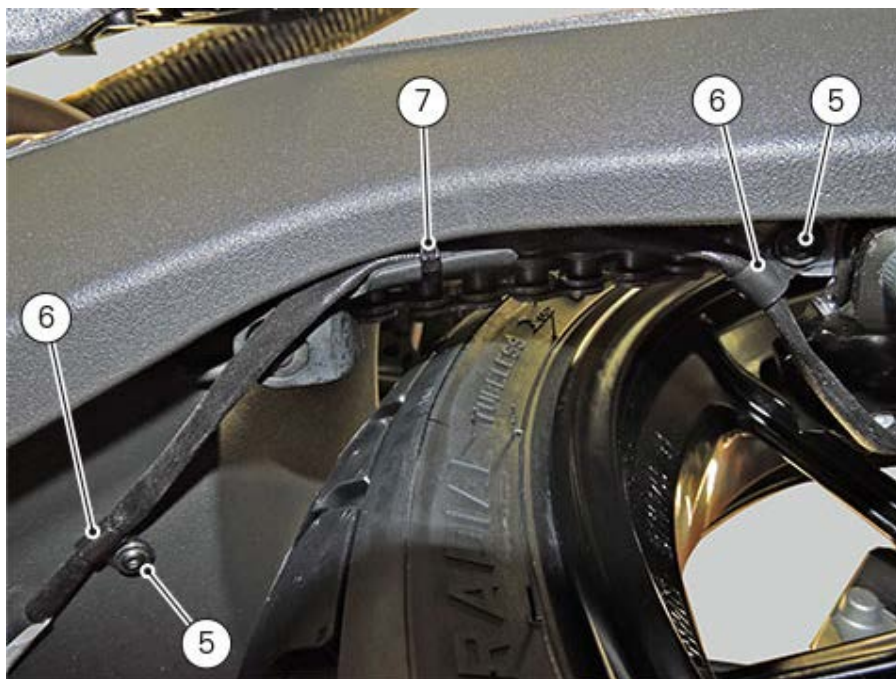

Remove the two screws (8) that retain the number plate holder subframe support (9) to swinging arm (10).

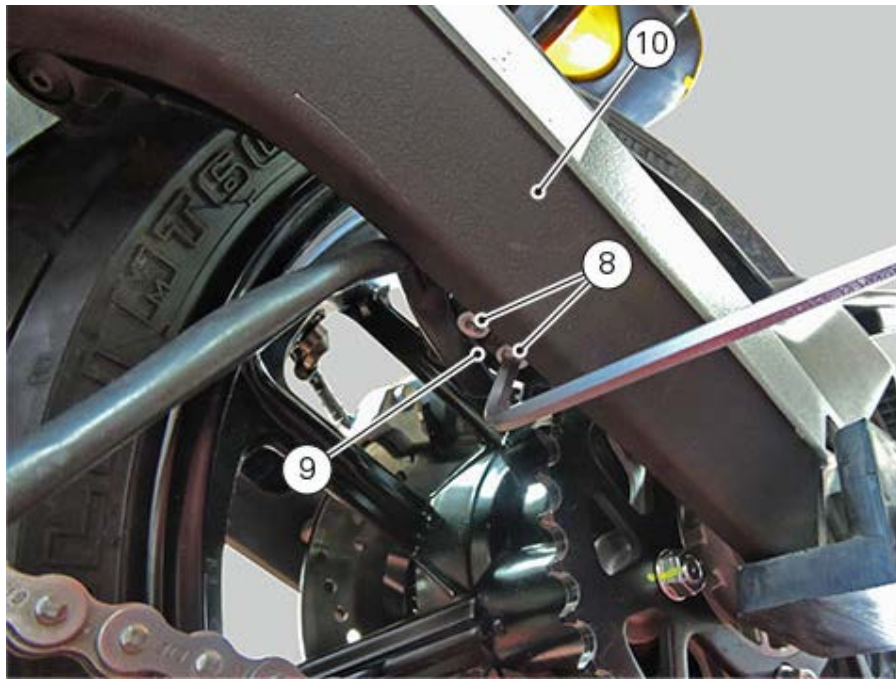

Remove screws (11) and (12) that retain the number plate holder subframe to the swinging arm.
Remove the number plate holder subframe.
In the picture the chain guard has not been removed yet.

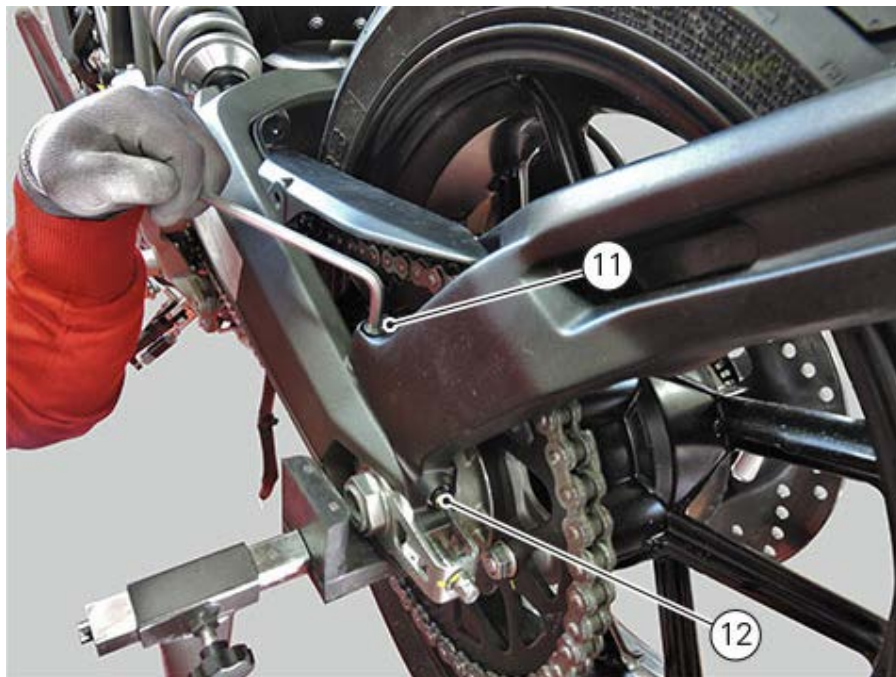

Disassembling the number plate holder

Remove screws (13) to release the number plate light wiring.

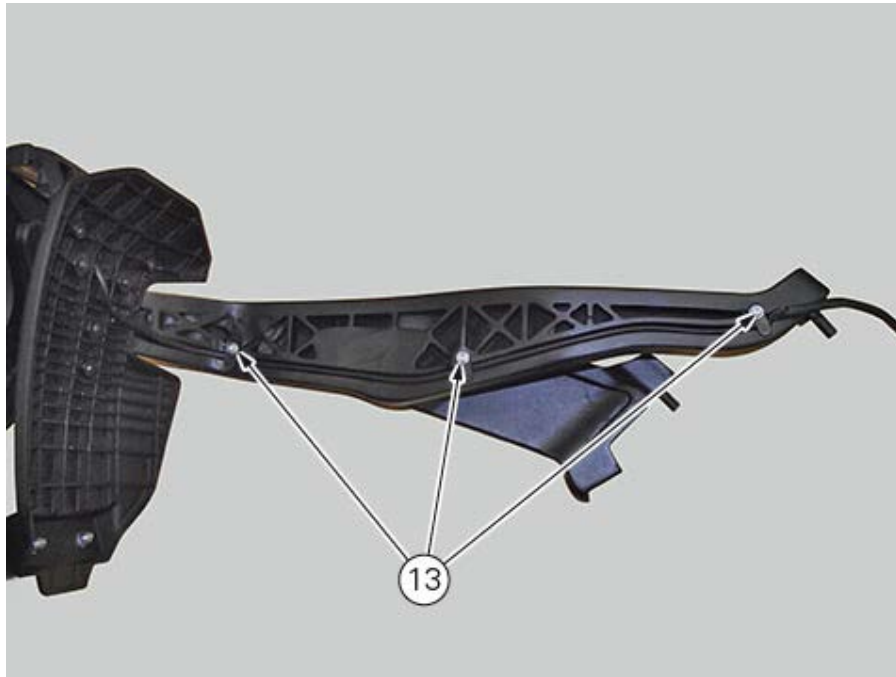

Remove the three screws (14) securing the number plate holder plate (15).

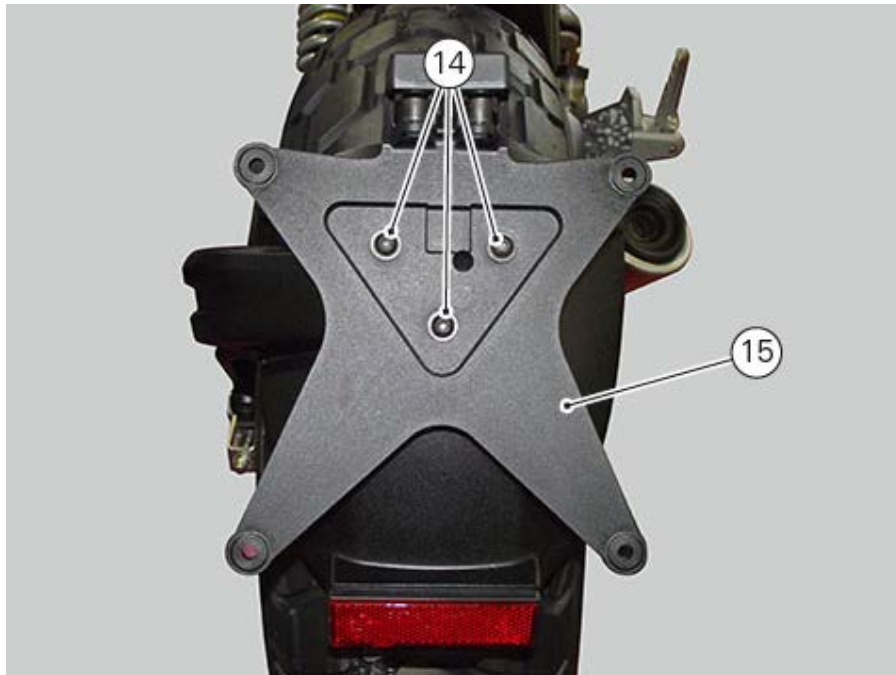

Remove the number plate holder from its support.



Remove the number plate light (17) by loosening the two screws (16).

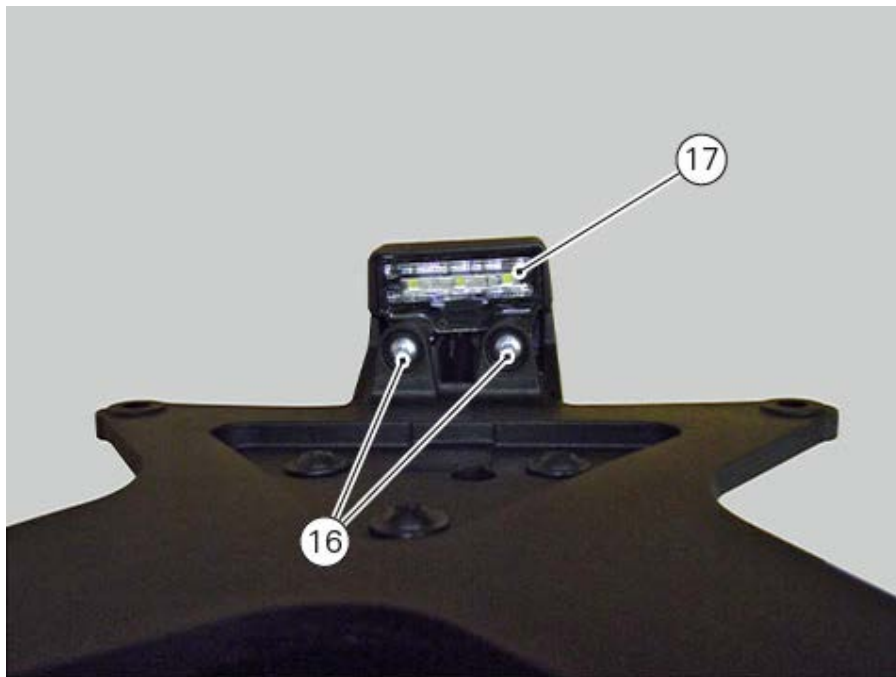

Refitting the electric components compartment

If previously removed, refit heat guard (4) on case (5) on the rear side with heat reflective material, as shown in the figure.

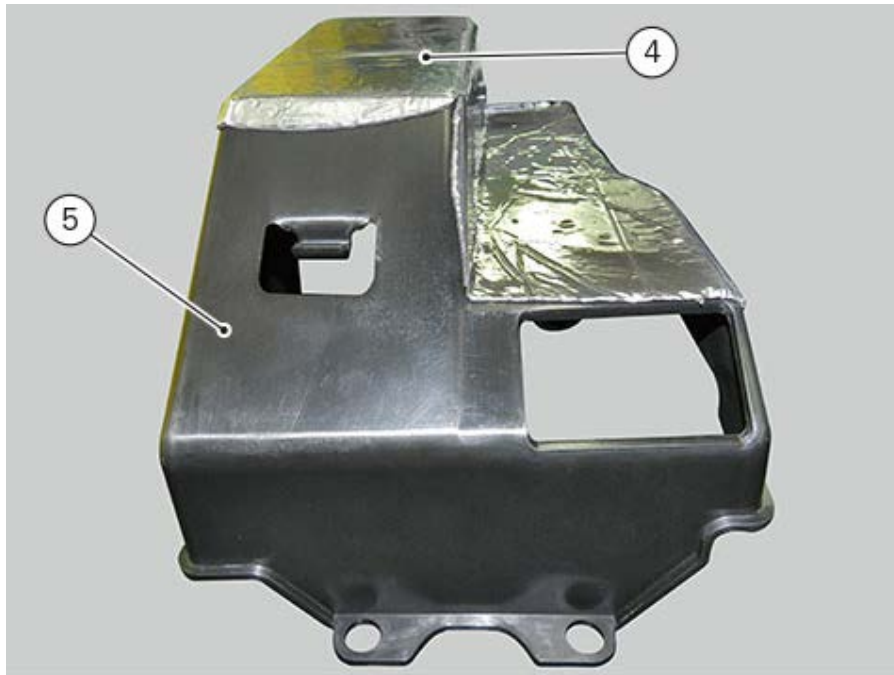
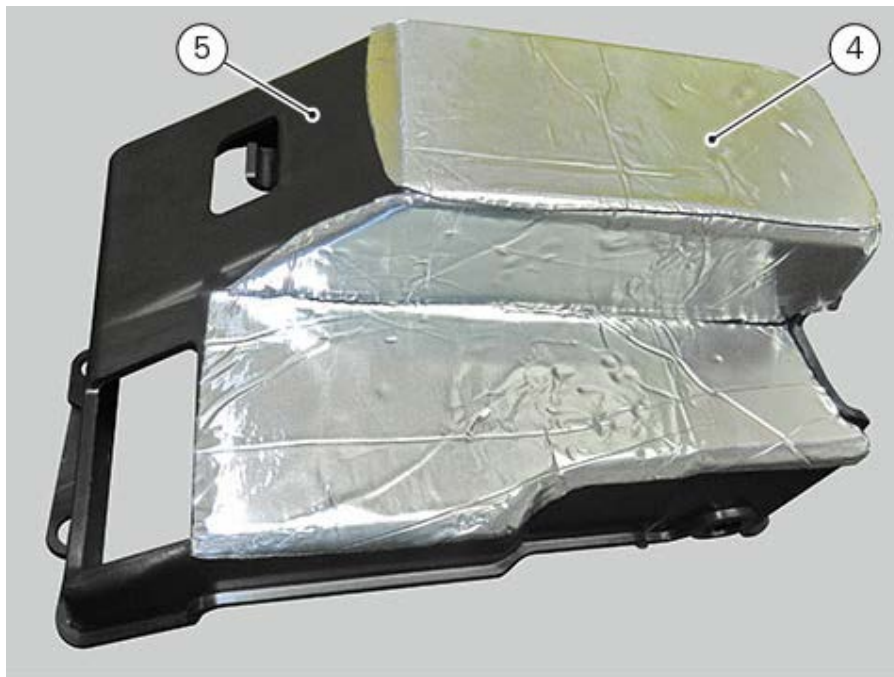

Important

Pay attention to avoid any air bubbles between the heat reflective material and the electrical components compartment.

Fit vibration damping pads (6) and fit spacer (7).

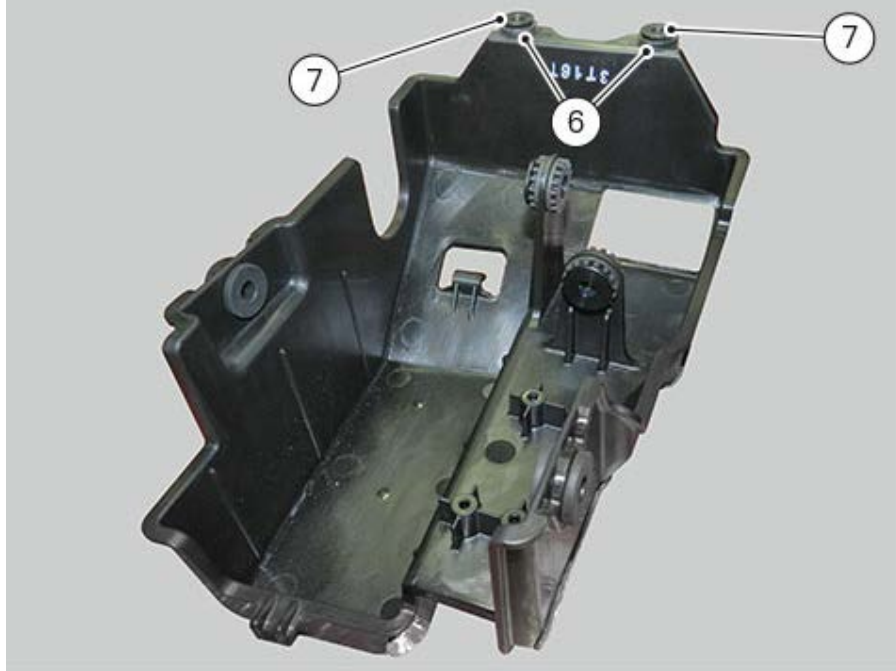
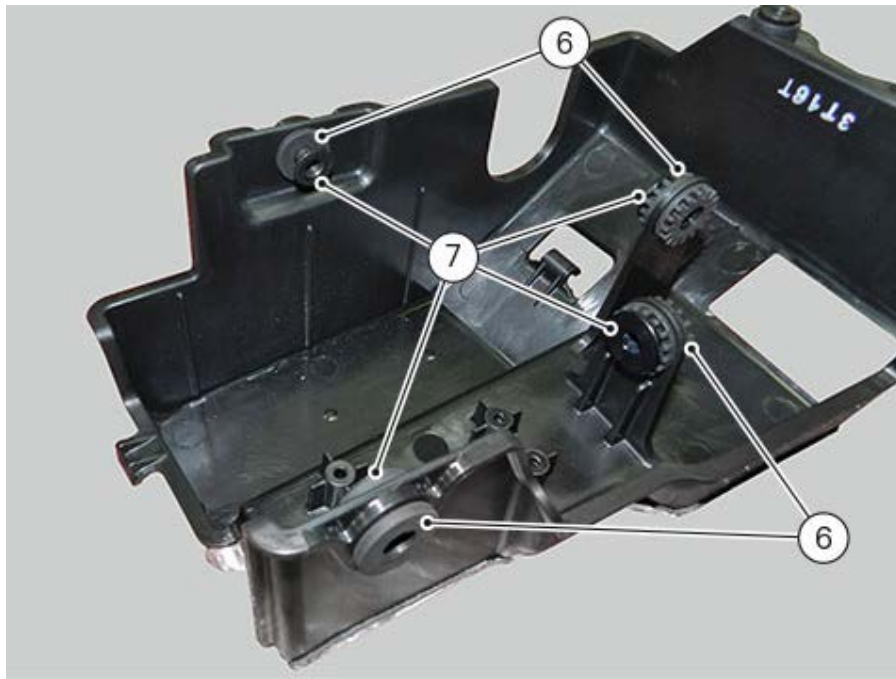

Position the solenoid starter support (8) on the suitable stud bolts.
Start screws (9) and tighten them to a torque of $1.5 \text{ Nm} \pm 10\%$.

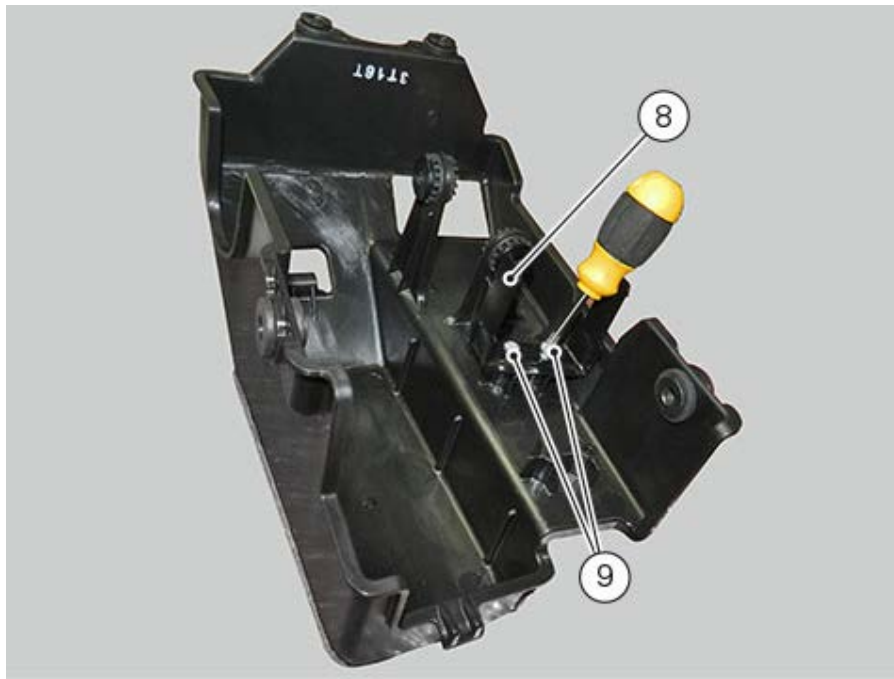

Position electrical components compartment in the frame.
Start screws (1) and tighten them to a torque of $5 \text{ Nm} \pm 10\%$.

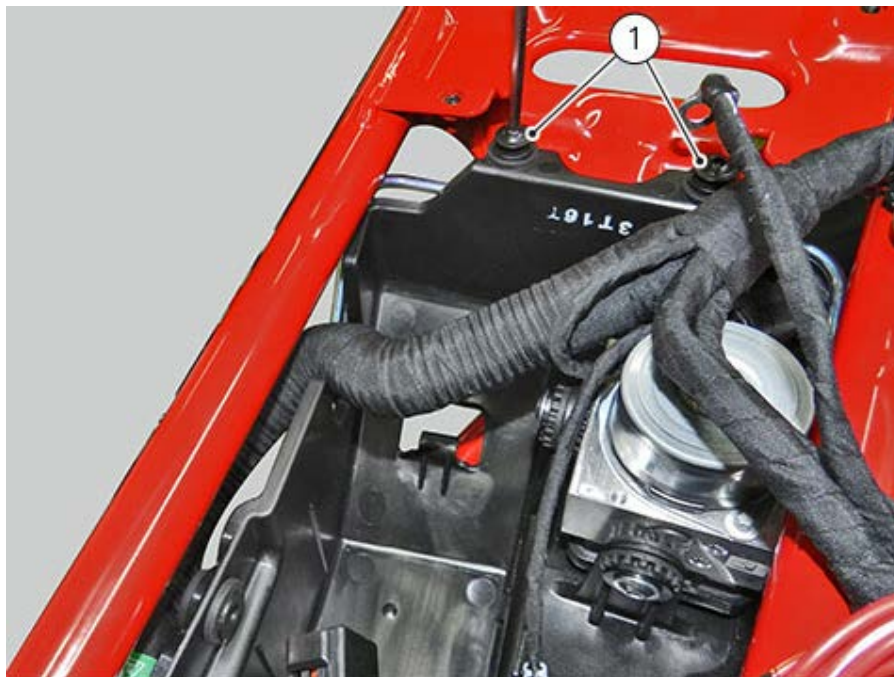

Position screws (10) from the internal side of the electrical components compartment.



Tighten nuts (2) and (3) to a torque of $\pm 5 \text{ Nm } 10\%$.

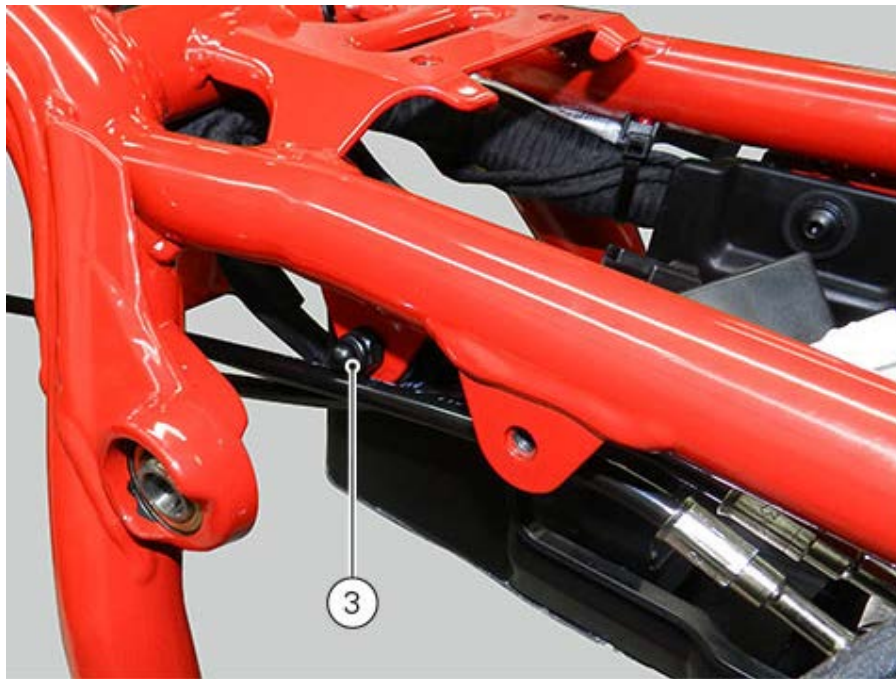

Removing the electric components compartment

Remove the seat ([Removing the seat](#)).

Remove the tail guard ([Removing the tail guard](#)).

Remove the battery.

Remove the fuse box.

Remove the ABS control unit ([Removing the ABS control unit](#)).

Loosen and remove the two rear screws (1).

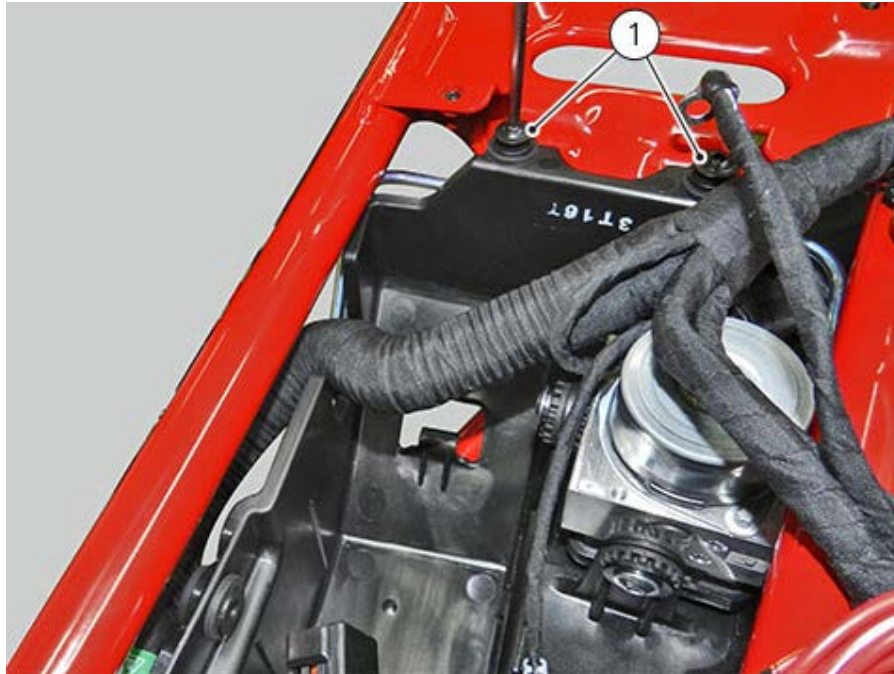

Loosen nut (2) and remove the screw from the internal side.



Working on the vehicle left side, loosen nut (3) and remove the screw from the internal side.

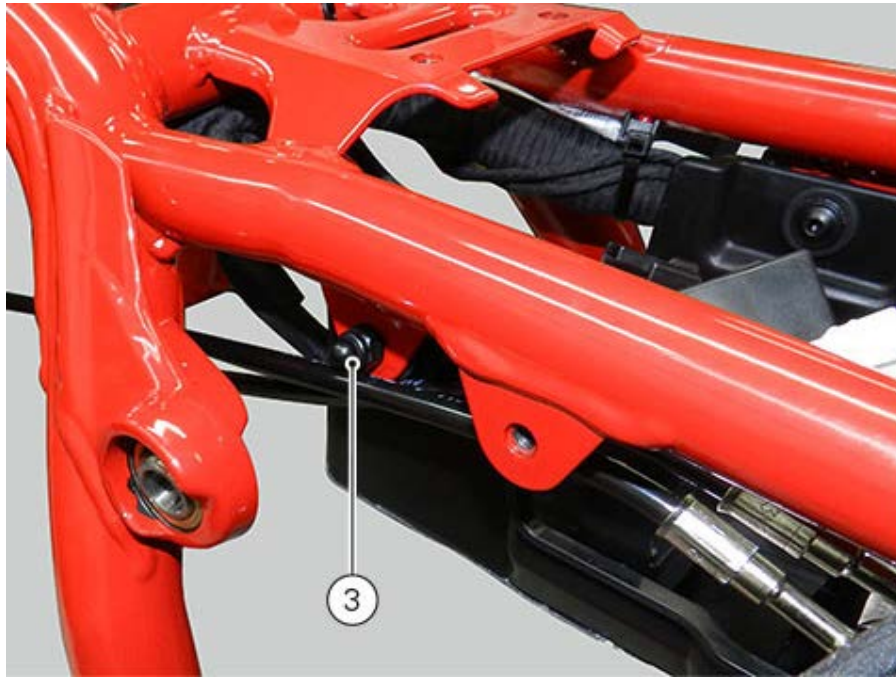

Refitting the tank

Make sure that two silent blocks (16) are present on both sides of the frame.



Position the tank on the frame so as to connect connector (15) and hoses (14).

For the connection, grip the flange and push it down (A).

Insert hose (14).

Connect the connector (15).

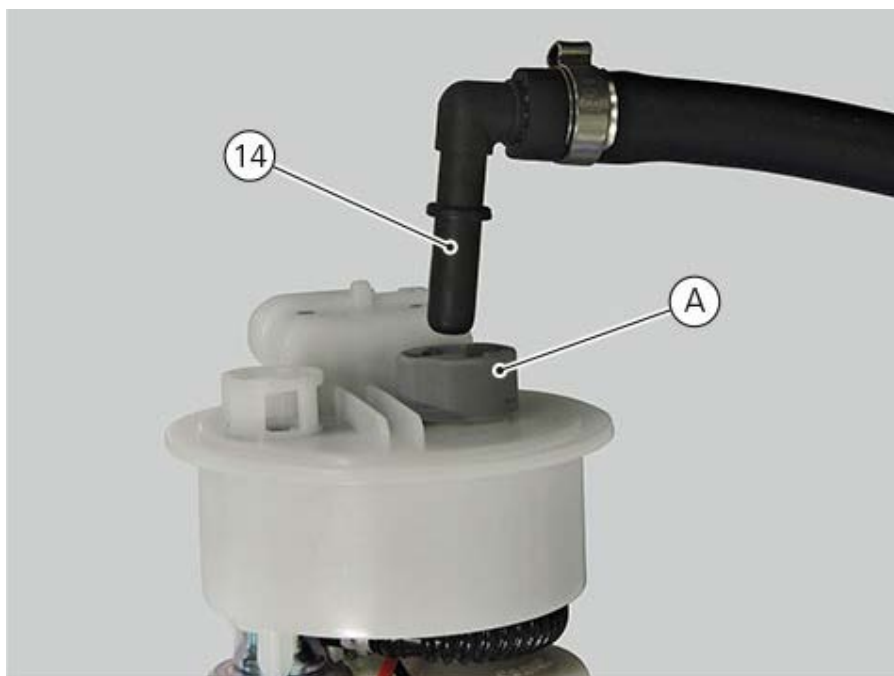

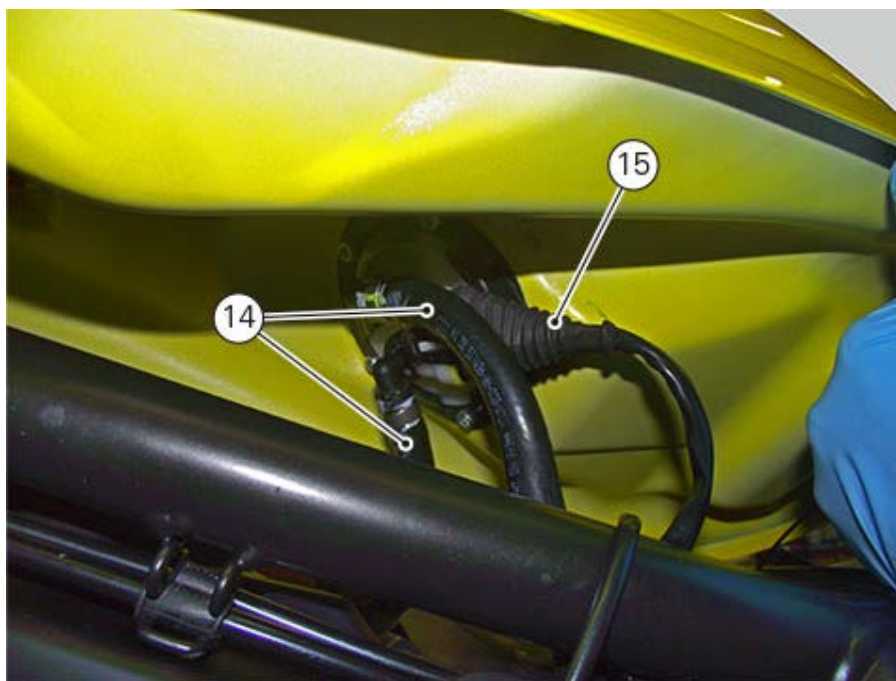
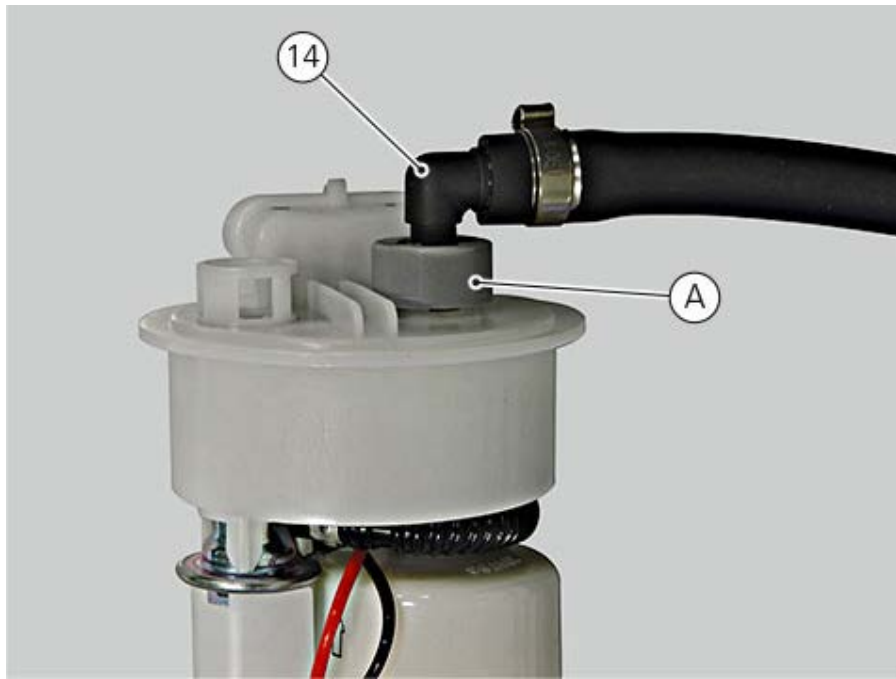

Tighten the two screws (13) to the silent blocks to a torque of $5 \text{ Nm} \pm 10\%$.



Tighten the two screws (11) of tank (12).



Refit the seat ([Refitting the seat](#)).

Refitting the tank side body panels

Position side body panel (1) engaging tab (6) in bracket (7) on tank (3).

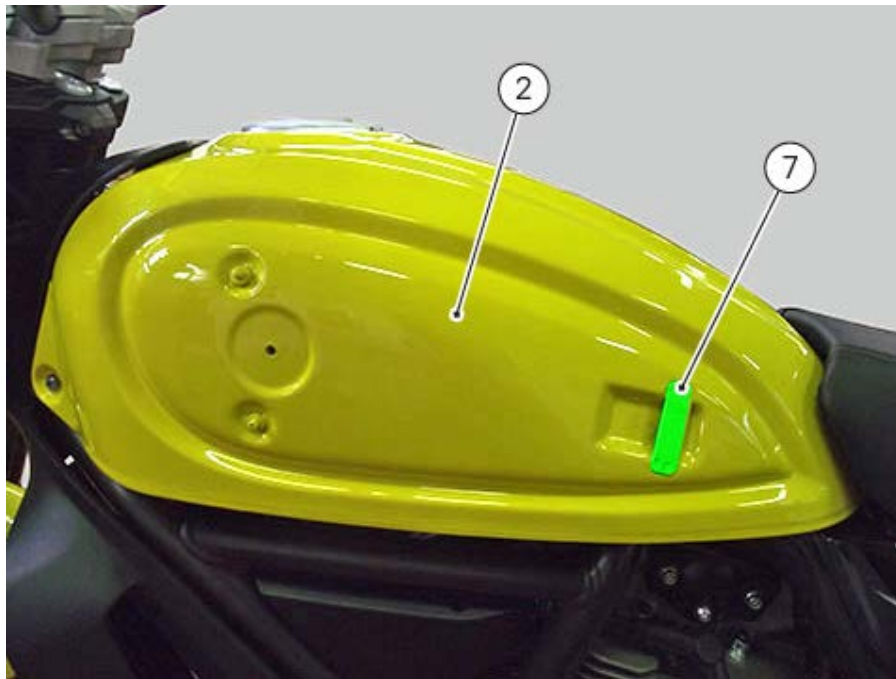
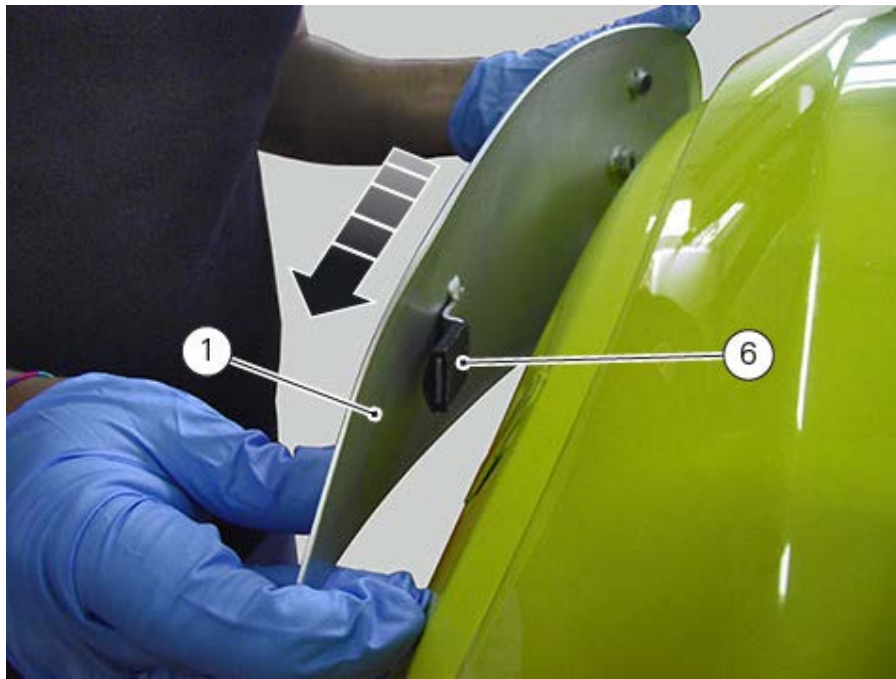

Tighten screw (2) retaining side body panel (1) to tank (3) to a torque of $5 \text{ Nm} \pm 10\%$.

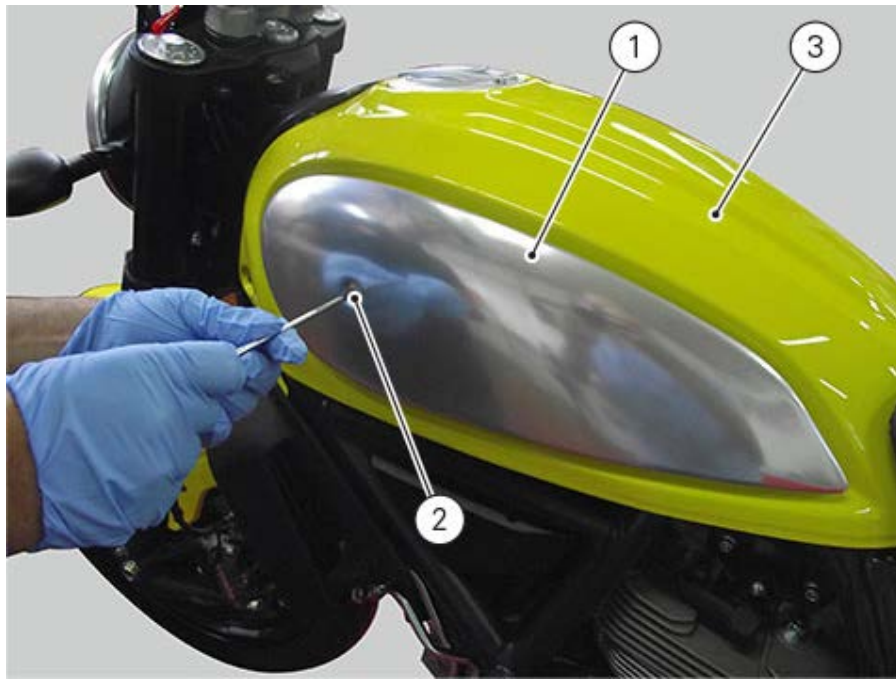

Reposition adhesive logo (A).
The image below shows the ICON customisation. The procedure is the same for all customisations.



Check that on the tank there are rubber elements (7).

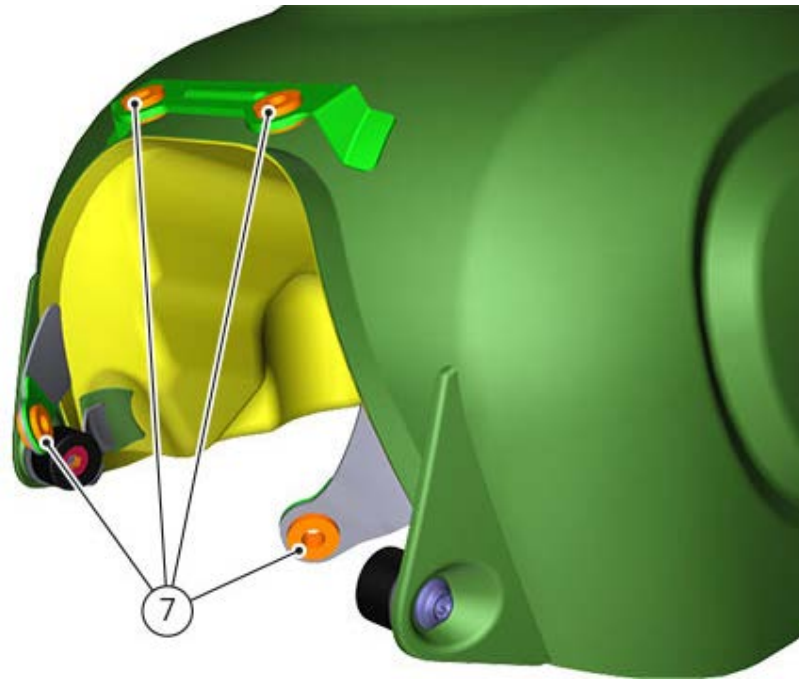

Fit the tank cover (6) by pulling it inwards to engage pins (4) in fixing points (5).

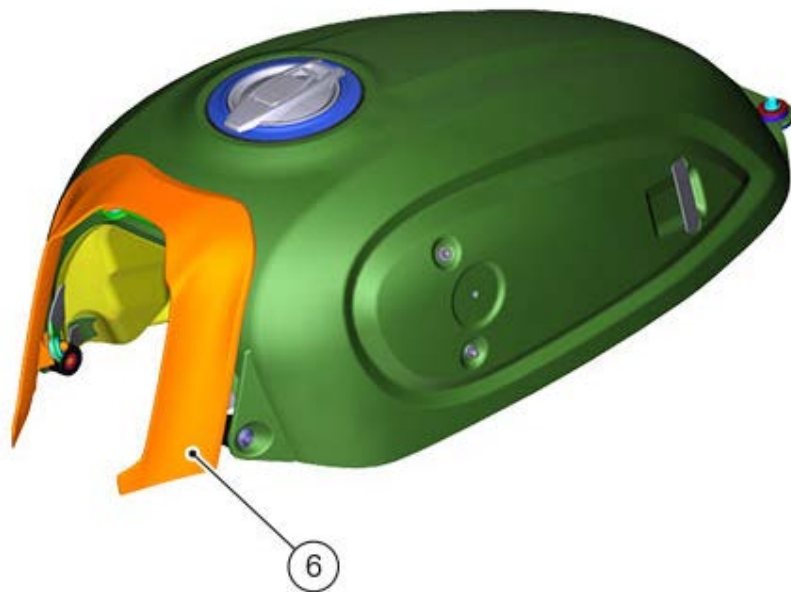

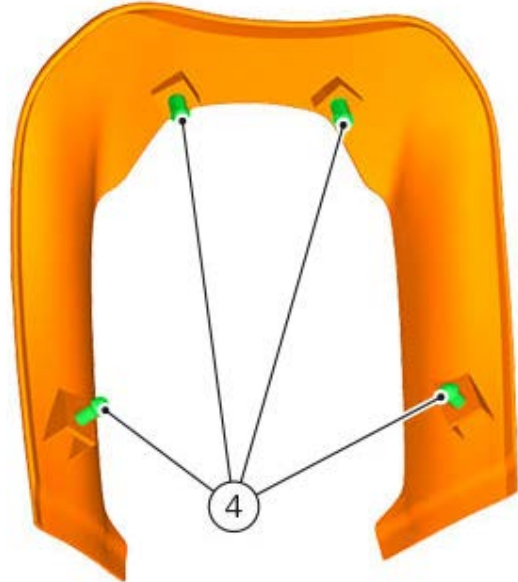
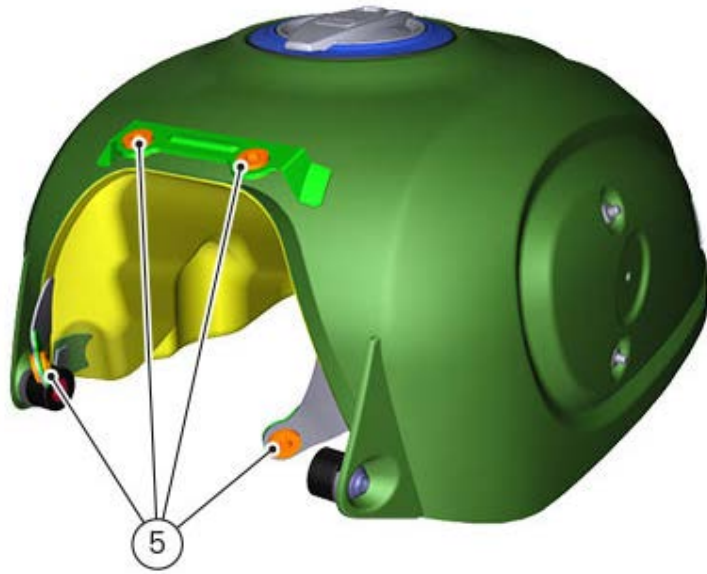

Refitting the fuel tank flange

If removed or damaged, fit seal (4) on pump (5) and lubricate it with the specified product.

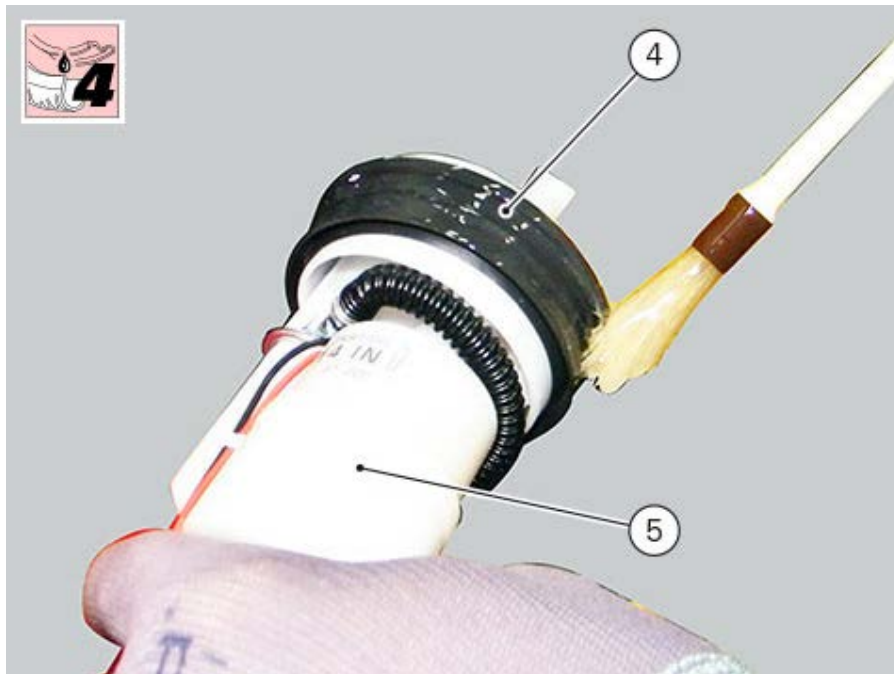

Insert the pump unit (5) in the tank seat (6) as shown in the picture.



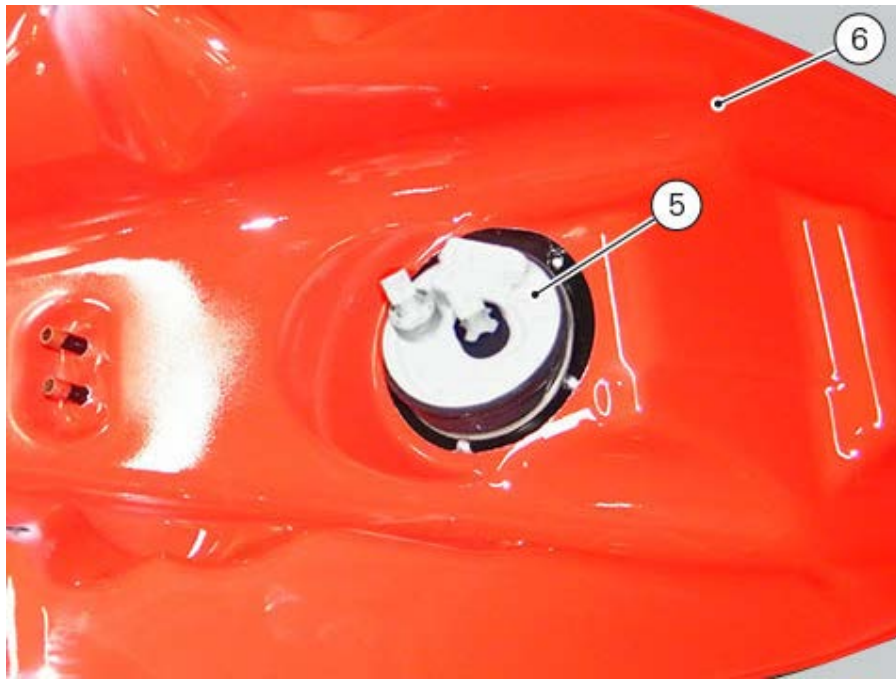

Position the pump locking flange (7) on pump (5), centring notch (8) on rib (9).

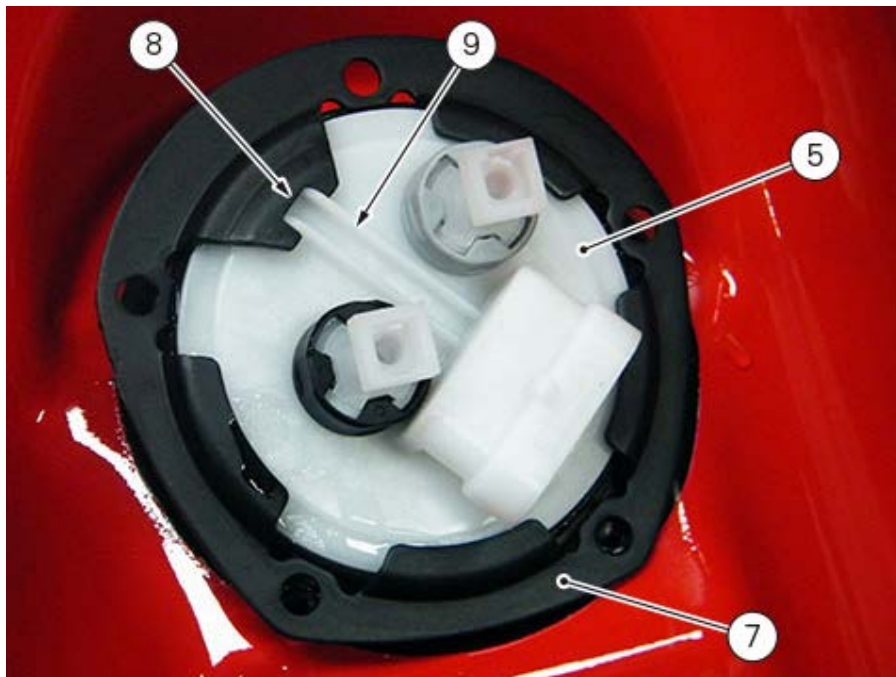

Turn flange (7) and pump (5) assembly by centring flange hole with the holes on the tank.
Start screws (2) and tighten them to a torque of $5 \text{ Nm} \pm 10\%$ respecting the indicated sequence.

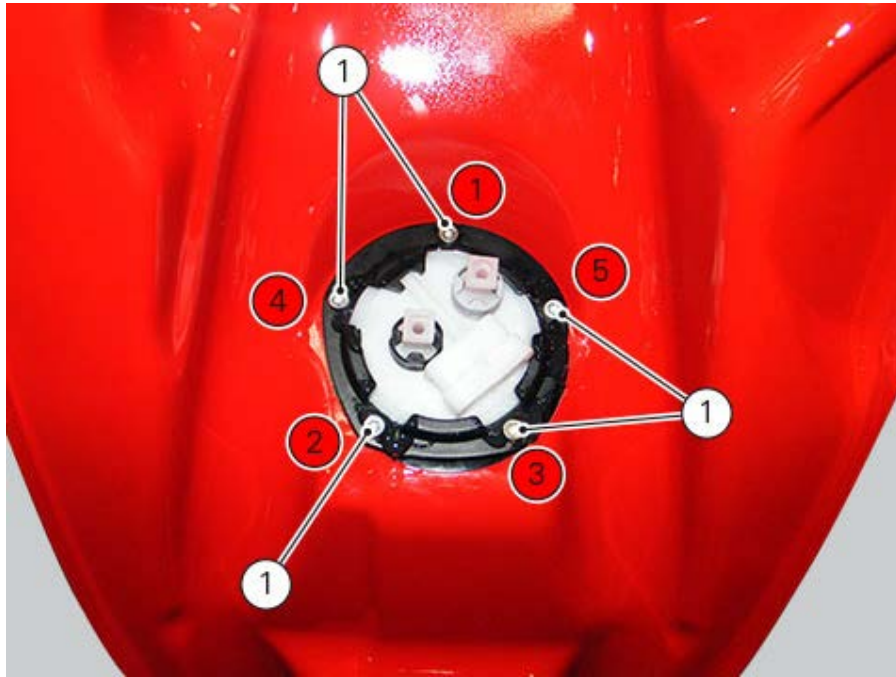

Use the indicated product to lubricate the contact areas of tabs (10) with the seal.



Removing the fuel tank flange

Loosen the screws (2) and remove fuel pump flange (3).

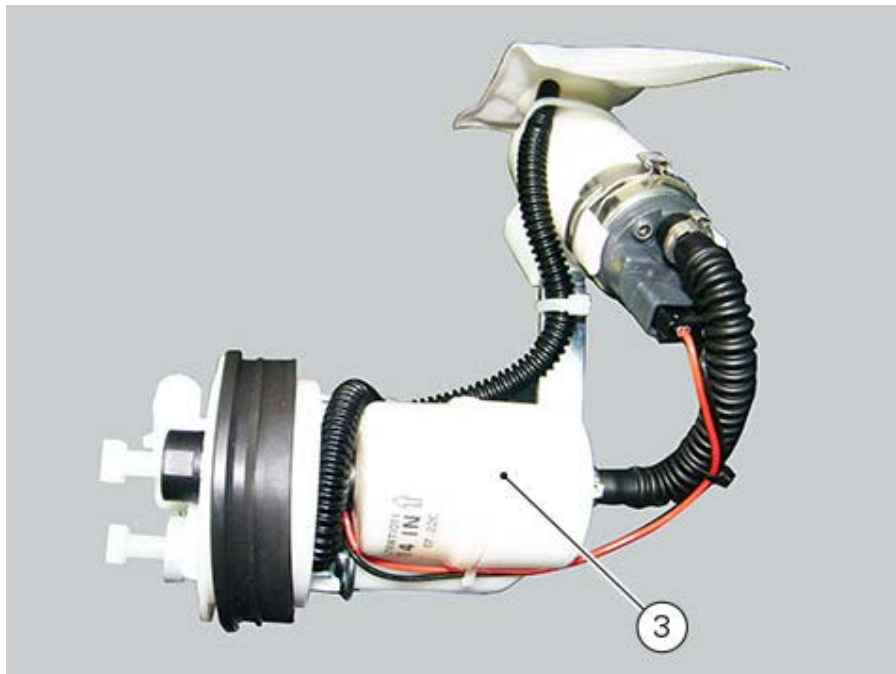

Refitting the tank filler plug

Insert the fuel plug and start the four retaining screws (1).
Tighten the screws (1) to a torque of $5 \text{ Nm} \pm 10\%$.

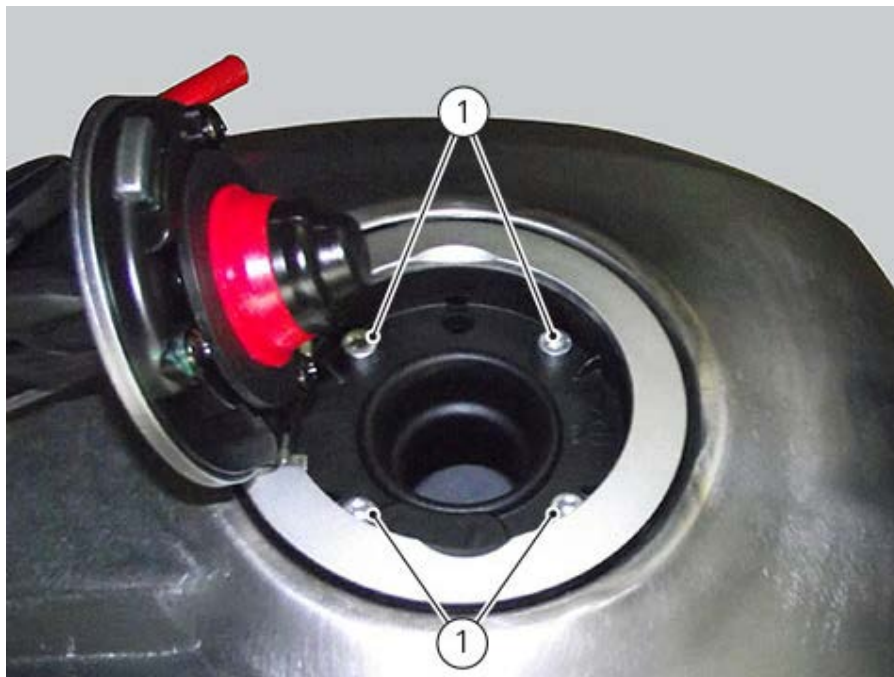

Removing the tank filler plug

Open the fuel plug and loosen the four retaining screws (1).
Remove the tank plug.

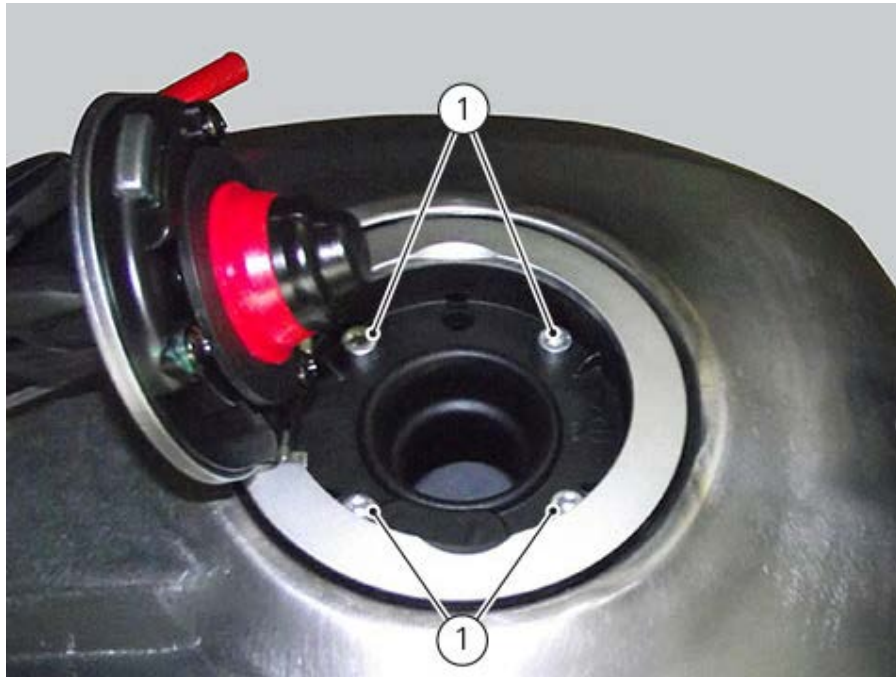

Removing the fuel tank

Remove the seat ([Removing the seat](#))

Loosen the two screws (11) securing tank (12) to the frame.
Working on both sides, remove screws (13).



Lift the tank as required to reach the fuel flange located under the tank.
Grip the flange and push it down (A).
Slide out hose (14). Disconnect the connector (15).

For clarity, the figures below show a flange removed from the tank.

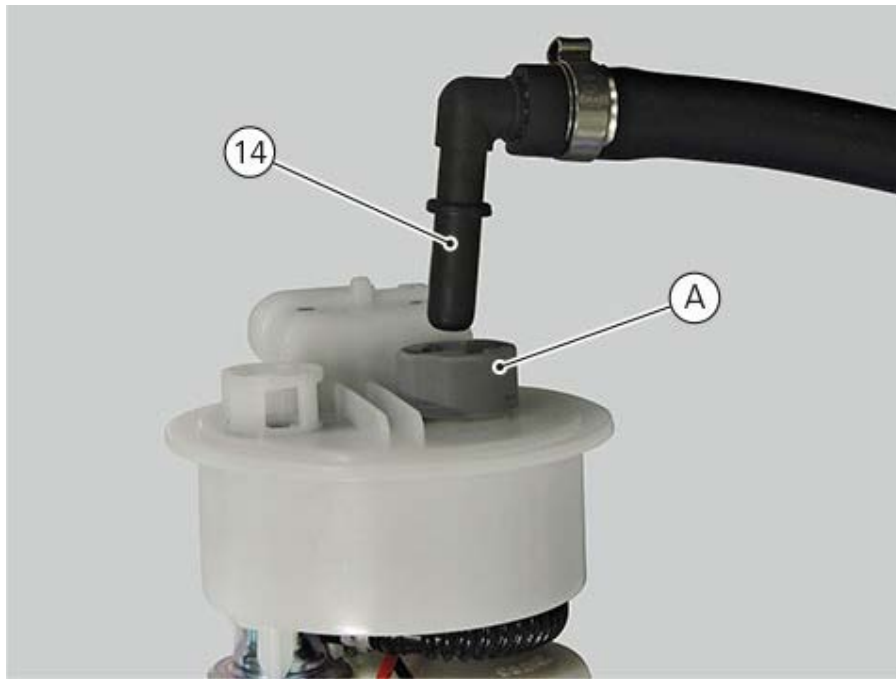
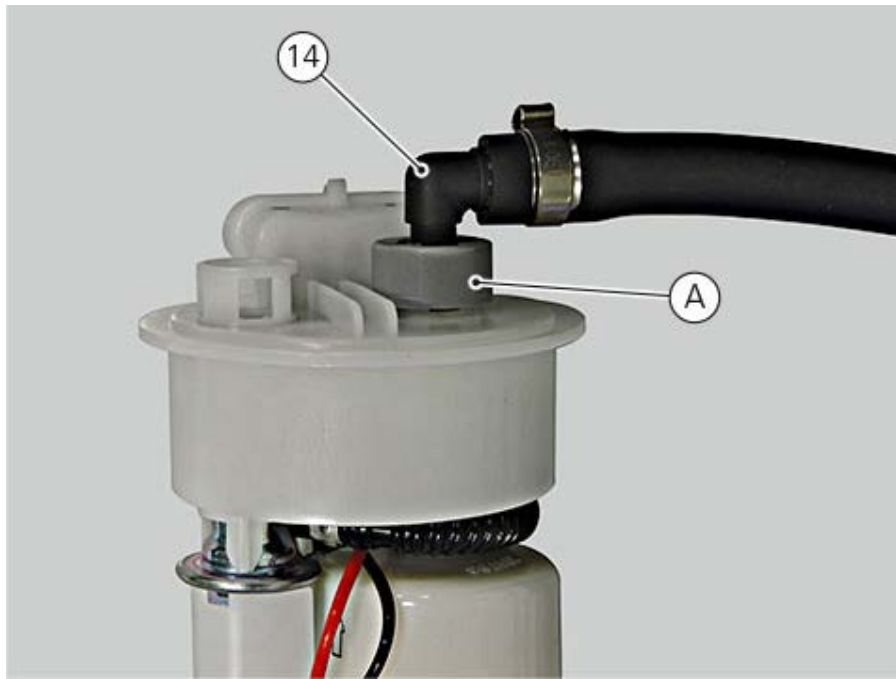

Disconnect hoses (14) and connector (15).

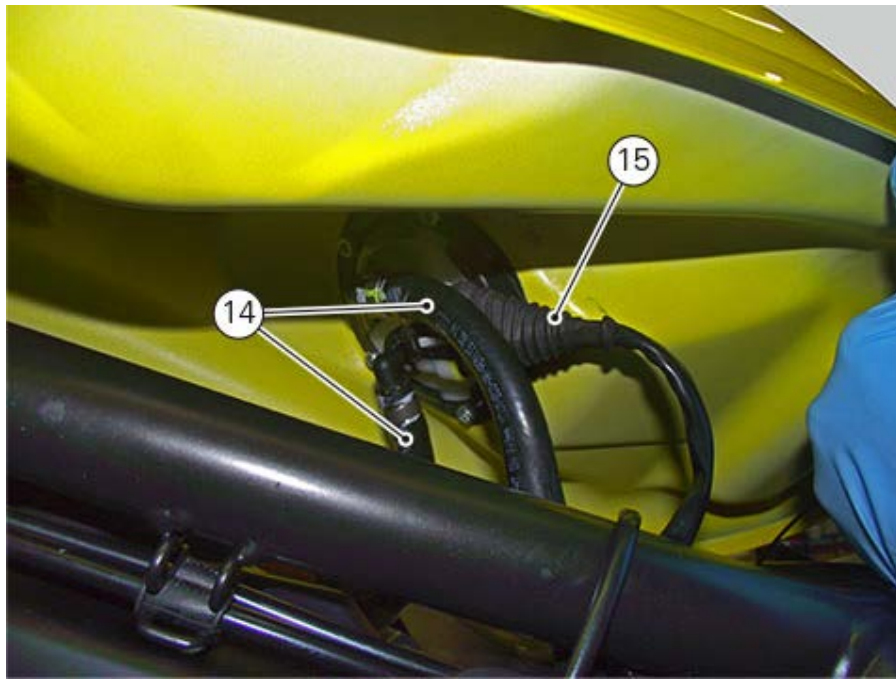

Note

Pay attention when disconnecting the fuel pipes. There may be fuel leakages.

Removing the tank fairings

Remove adhesive logo (A).

The image below shows the ICON customisation. The procedure is the same for all customisations.



Remove screw (2) retaining side body panel (1) to tank (3).

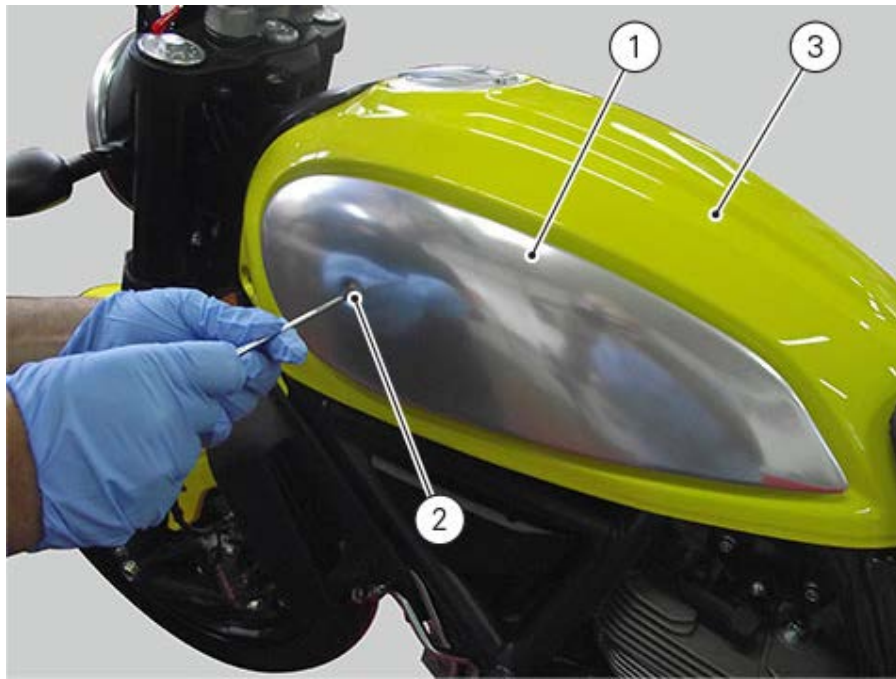

Remove side body panel (1) by sliding it towards the vehicle front side.



Remove the tank cover (6) by pulling it outwards to remove pins (4) from fixing points (5).

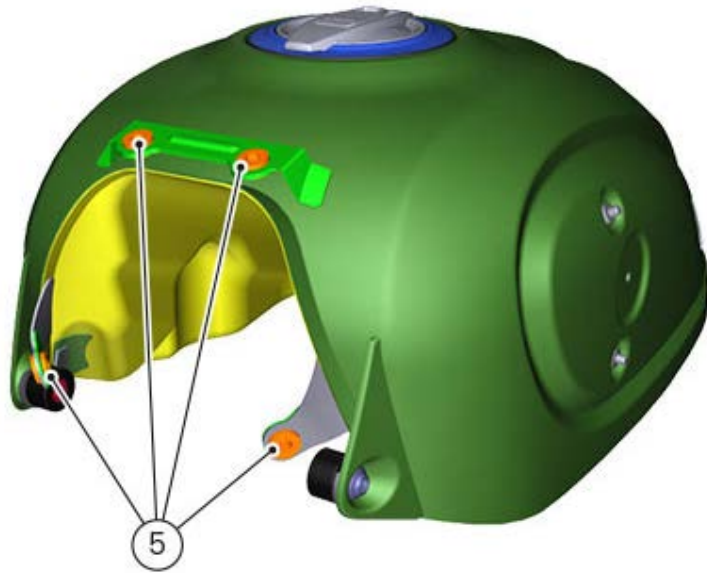
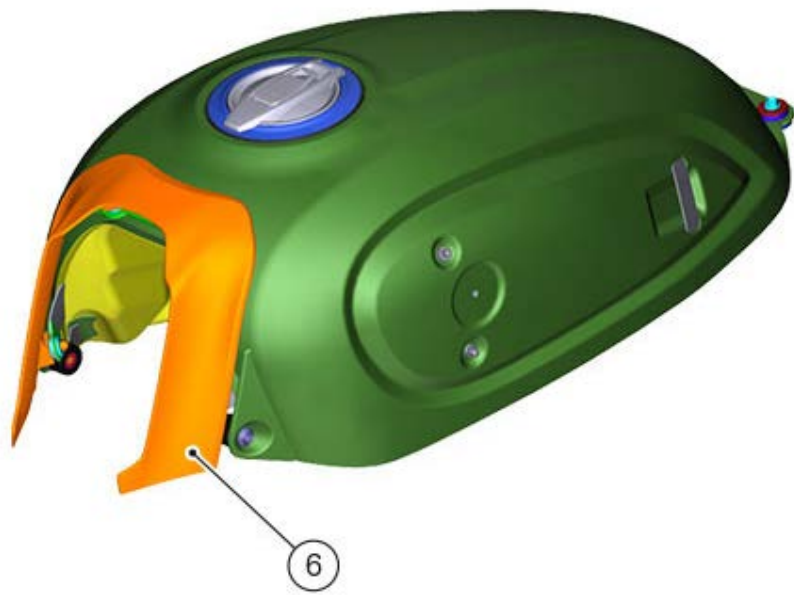

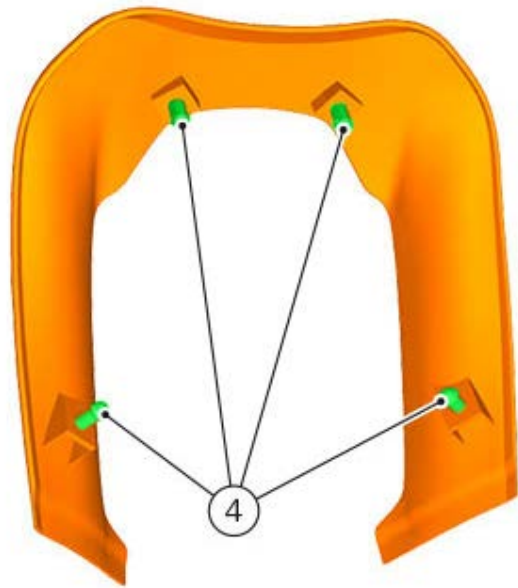

Refitting the throttle body

Position the throttle body inside the airbox.
Fix it by tightening clip (16) to a torque of $1.5 \text{ Nm} \pm 10\%$.



Refit the remaining part of the airbox as described in paragraph "[Refitting the airbox](#)".

Refitting the intake manifold and injectors

Position the intake manifold (15) with relevant clamps (13) and (14) on the horizontal cylinder manifold (16) and the vertical cylinder manifold (17).
Tighten the two clamps to a torque of $3 \text{ Nm} \pm 10\%$.

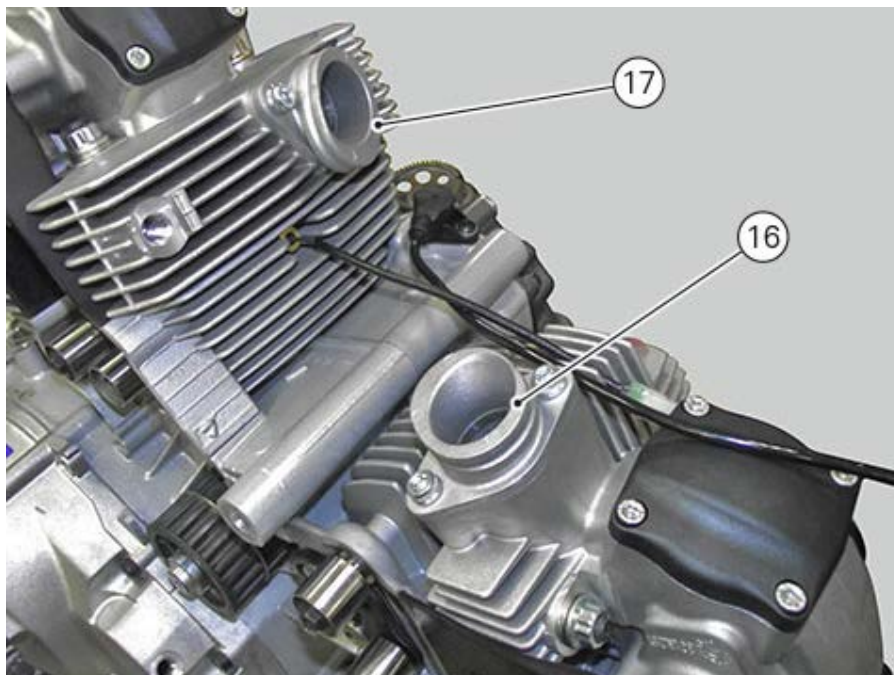

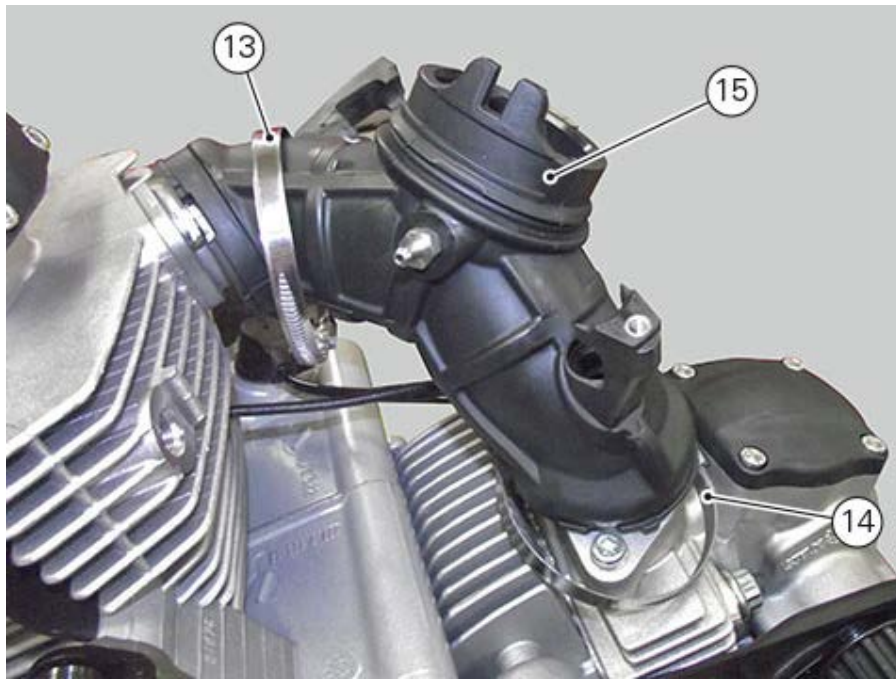

Apply specified grease to the O-ring (18).

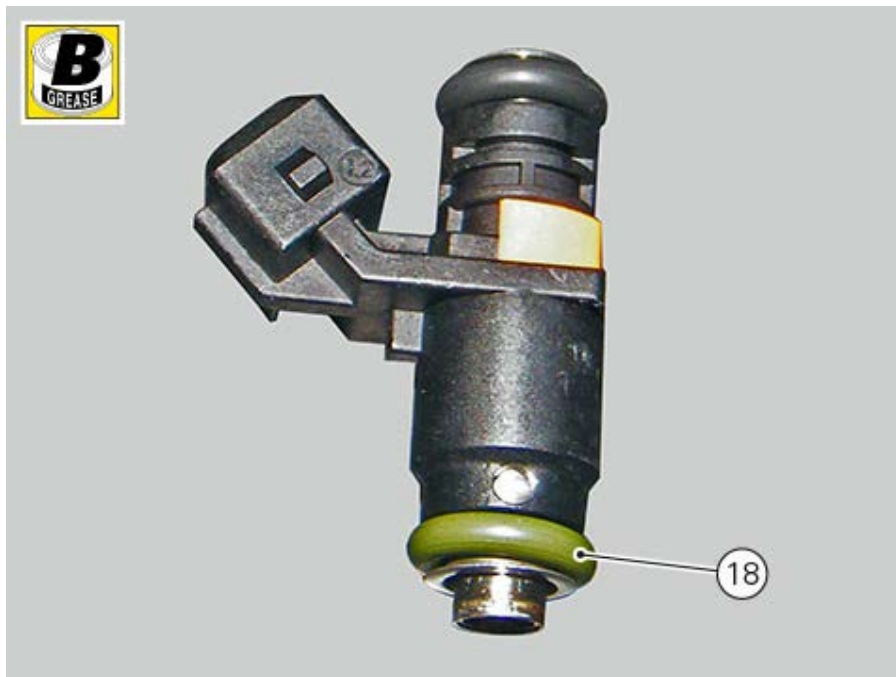

Insert injector (11) of the horizontal cylinder in injector (12) of the vertical cylinder, in the suitable seat (A) on the intake manifold (15).

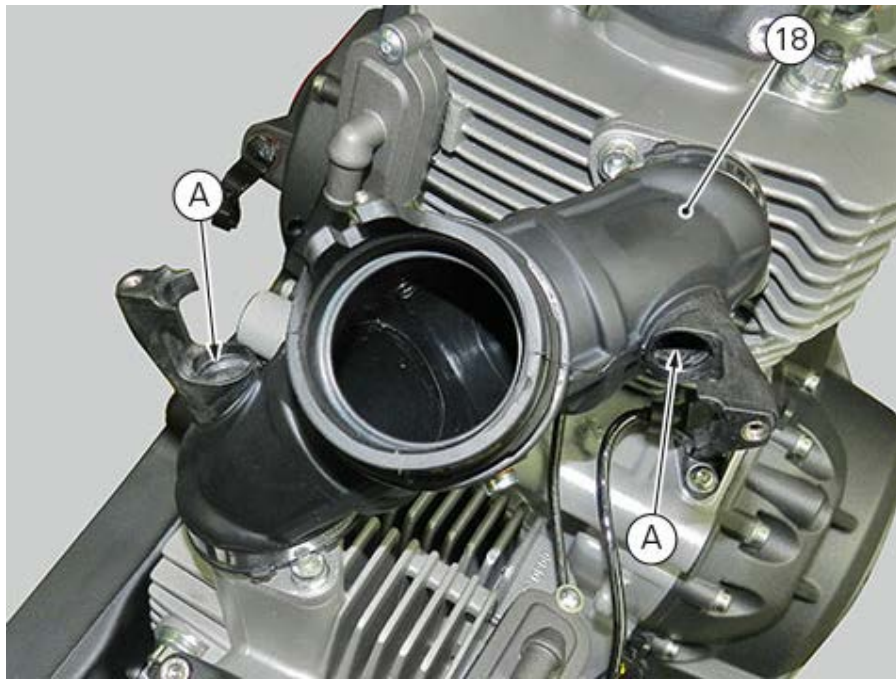

Important

In order to avoid damaging the O-rings of the injectors, fit the injectors into the unions fully home, keeping them in line with their relevant seat.

Fit union (10) on the vertical cylinder injector as shown in the figure.
Tighten the screw (9).

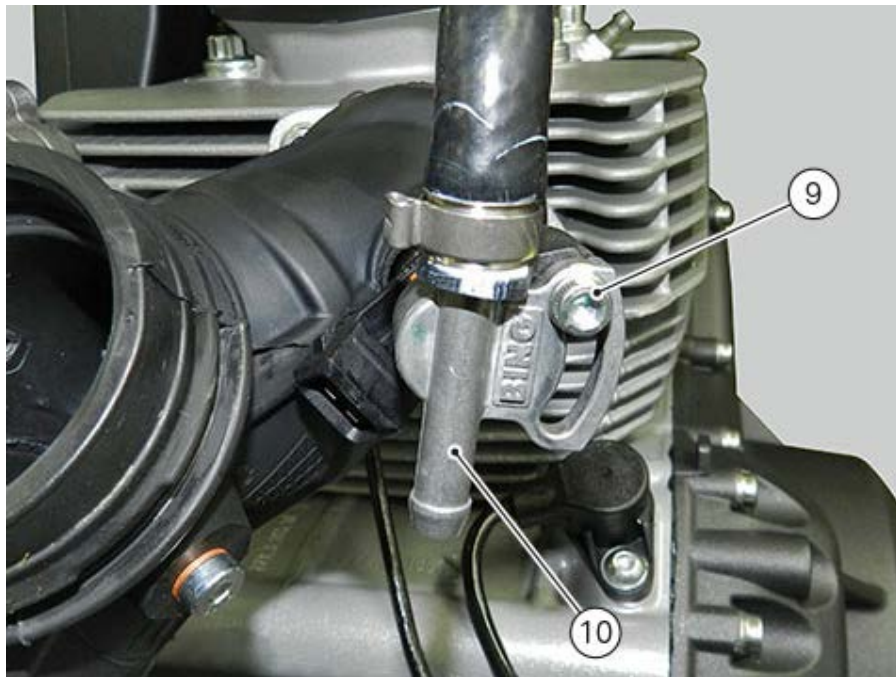

Fit union (8) on the horizontal cylinder injector as shown in the figure.
Tighten the screw (7).

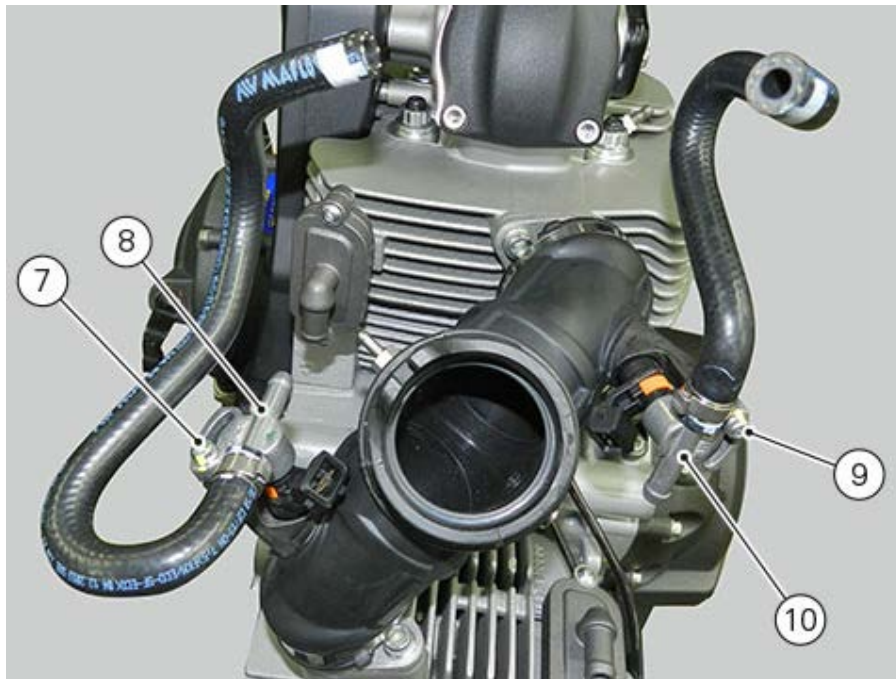
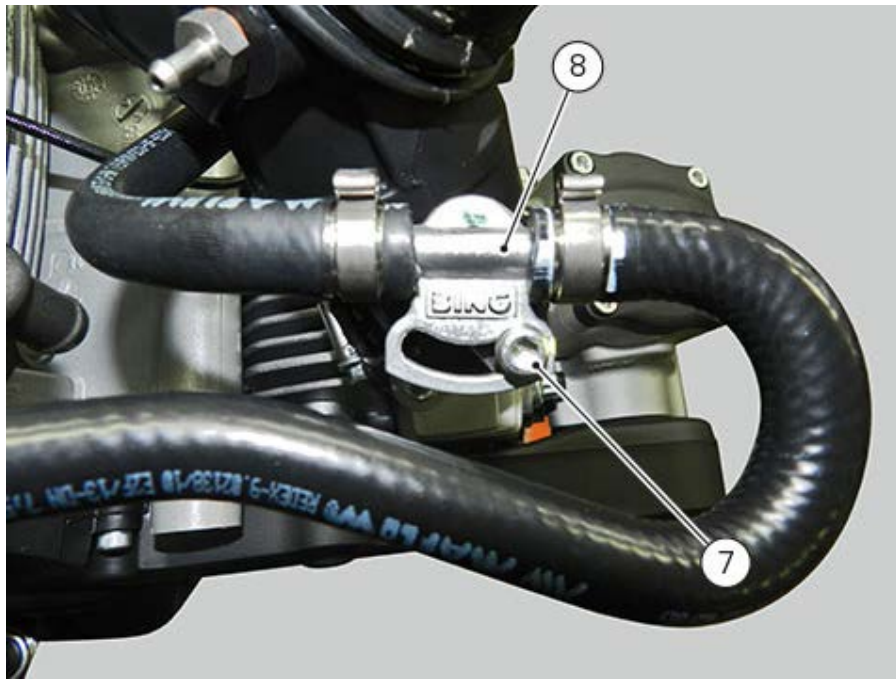

Connect the Map Sensor hose (3) and fix it with clip (4).

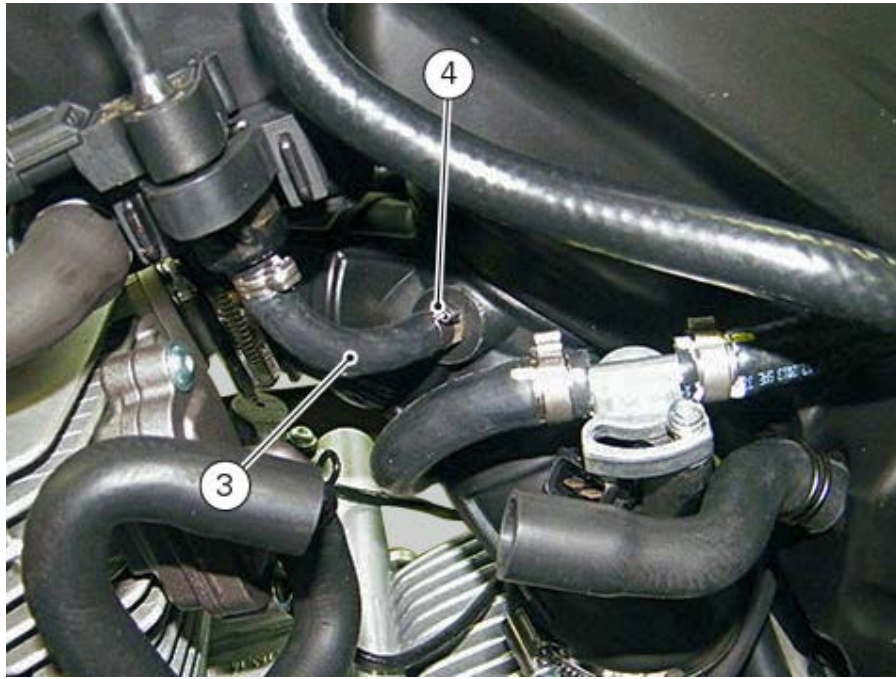

Reconnect the horizontal cylinder connector (1) and the vertical cylinder connector (2).





Removing the throttle body

Remove all components up to the throttle body as explained in paragraph "[Removing the airbox](#)". After releasing the throttle body from the wiring and the throttle cable, loosen clip (16) to remove it.



Removing the intake manifold and injectors

After removing the airbox, proceed as follows.

Disconnect the horizontal injector (1) and the vertical injector (2).





Disconnect the Map Sensor hose (3), removing clamp (4).

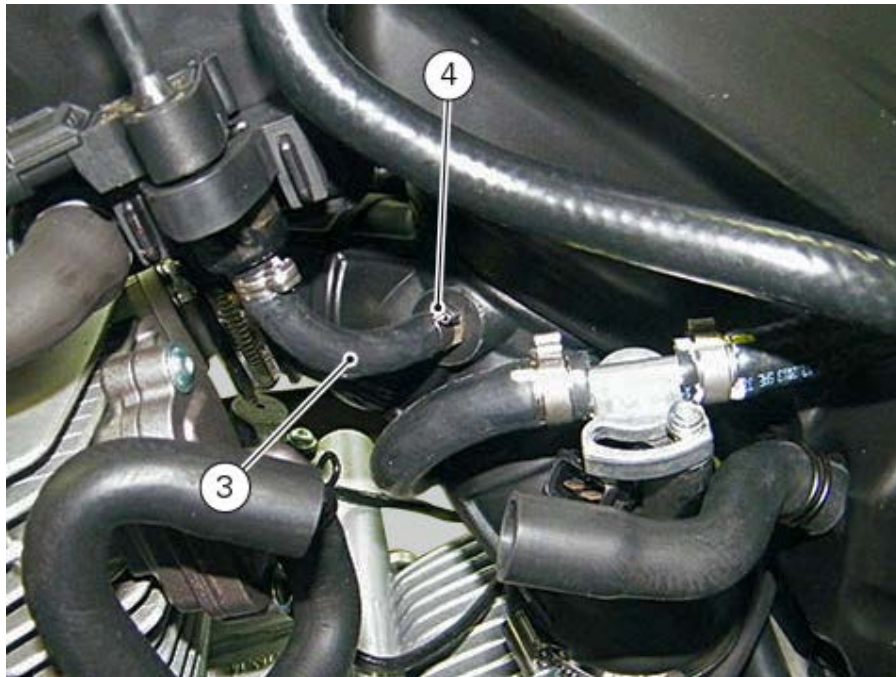

Disconnect hose (5), removing clamp (6).
Undo the screw (7) and remove the horizontal cylinder head injector union (8).
Undo the screw (9) and remove the vertical cylinder head injector union (10).

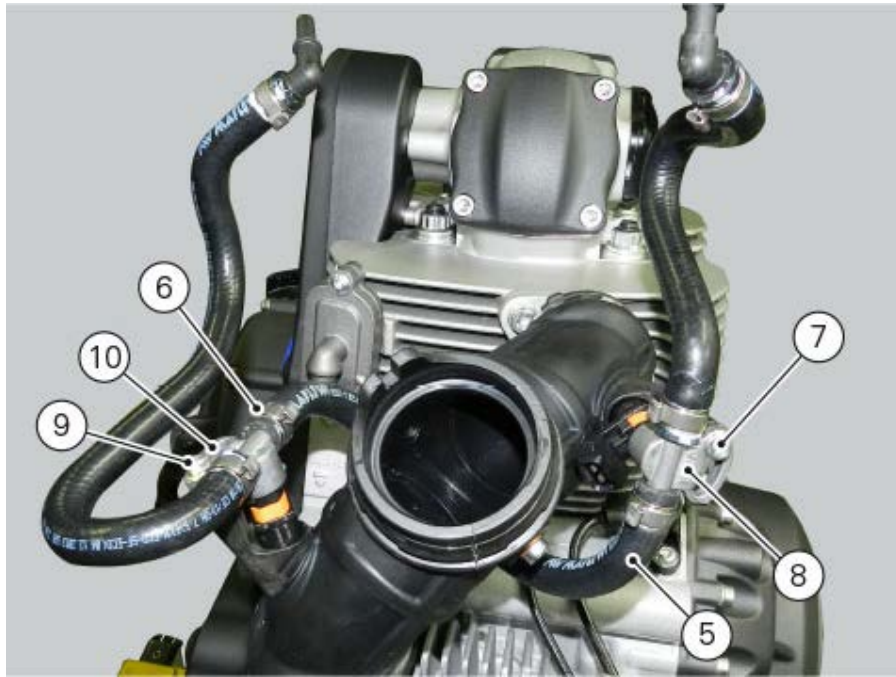

Remove the horizontal cylinder injector (11) and the vertical cylinder injector (12).

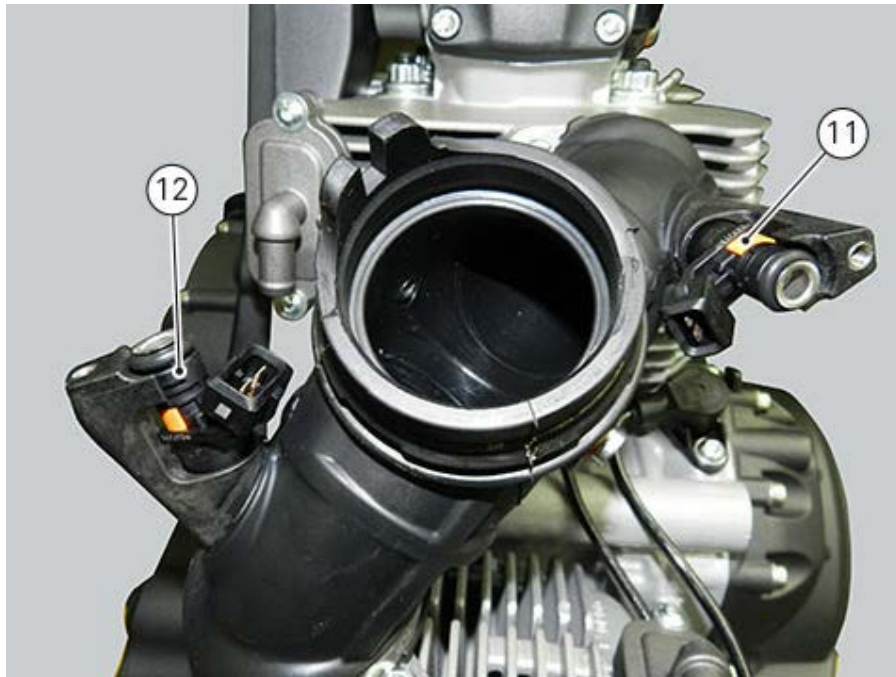

Unscrew the two clips (13) and (14) and remove the intake manifold (15).

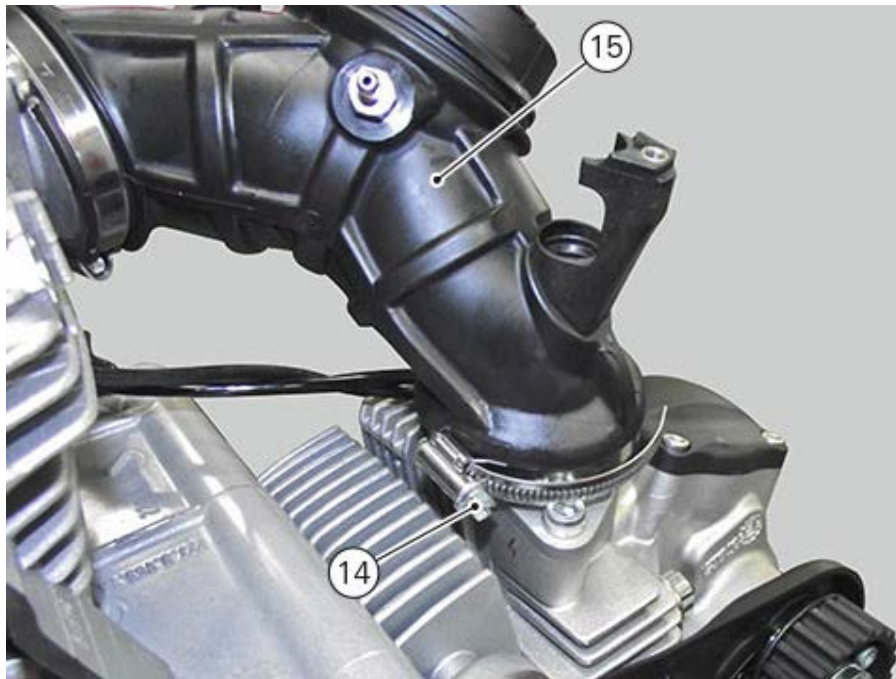
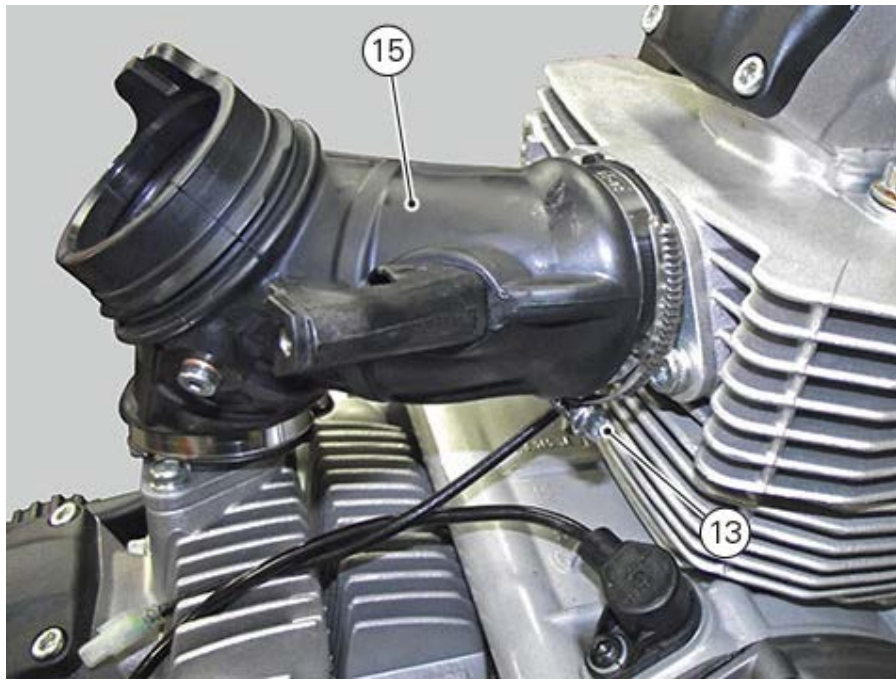

Refitting the airbox

If previously disassembled, reassemble the airbox as explained below:

Fit two vibration damping pads (19) in the relevant brackets and fit spacers (20) as shown in the figure.

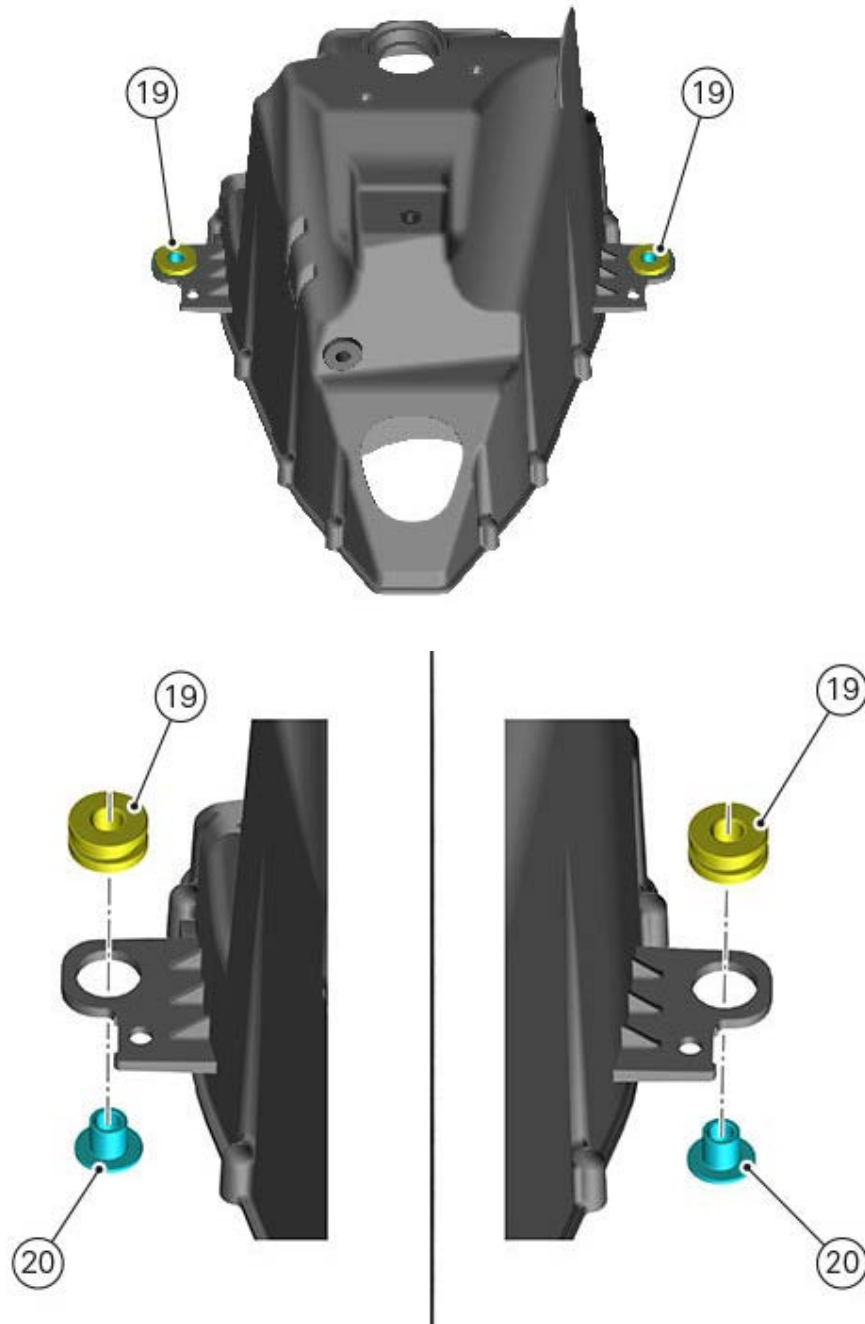

Fit the two clips (21).

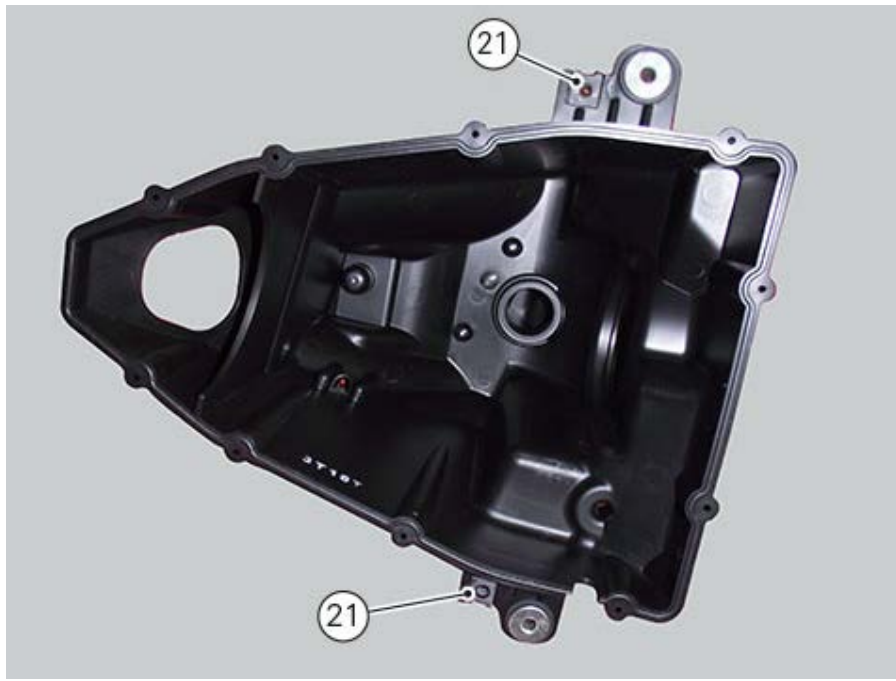



Fit seal (22) in its seat on the airbox.



Fit two spacers (23) as shown in the figure.



Fit blow-by box (24) fully home on airbox by inserting union in the relevant seat.



Start screws (25) and tighten them to a torque of $3 \text{ Nm} \pm 10\%$.



Use the indicated product to lubricate tabs (26) of the blow-by box.

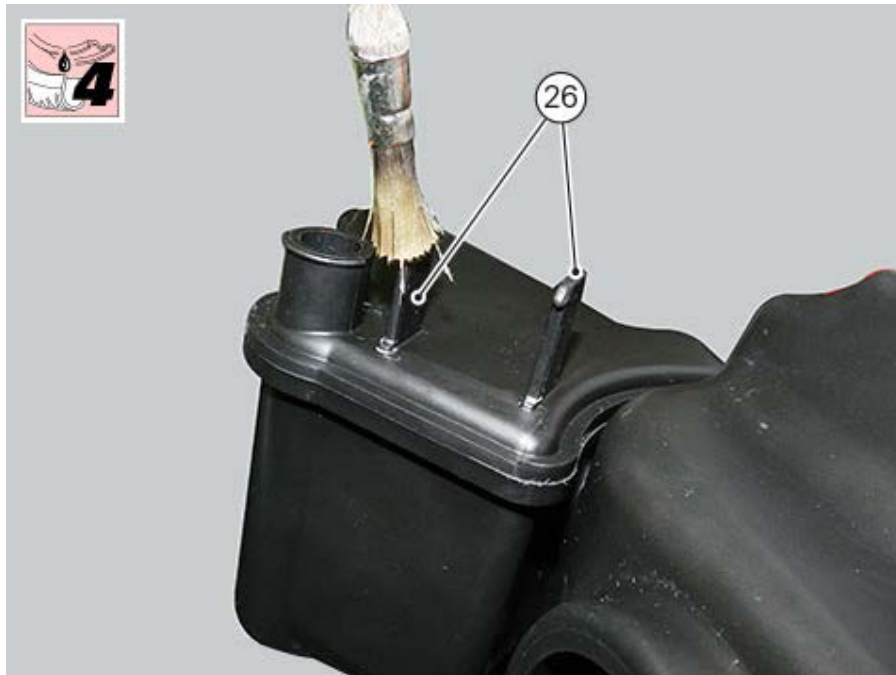

Engage the MAP_SENSOR support fully home on the just-lubricated tabs.
Apply the specified lubricant in the hole and on pin (28).



Lubricate MAP-SENSOR seal (29) using the specified product.

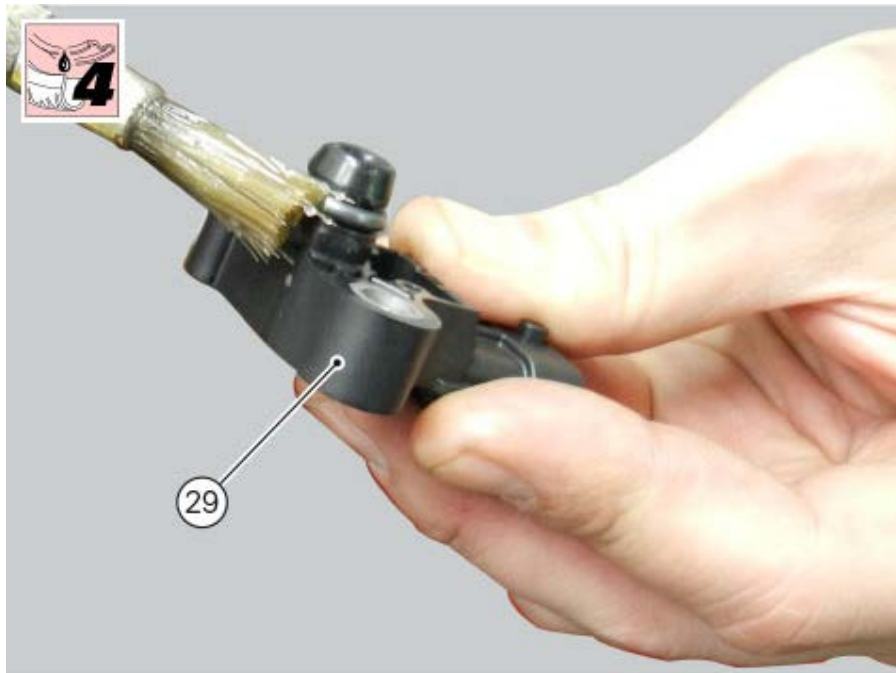

Fit MAP-SENSOR (29) on the support by introducing the pin with O-ring in the support recess and, at the same time, pin in the MAP-SENSOR hole.

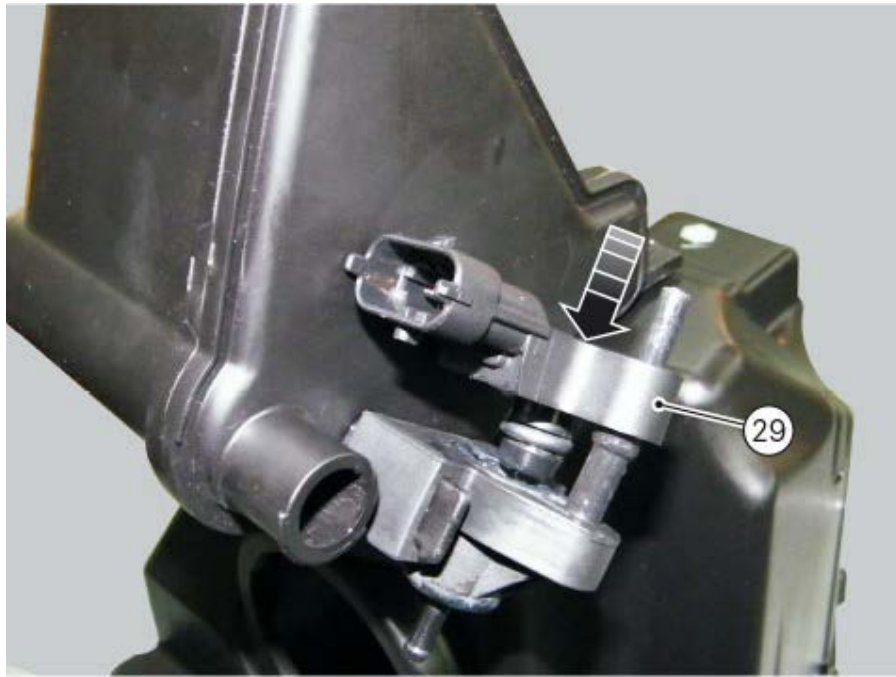

To ensure a correct assembly, pin must be pulled, letting the poppet (30) get completely out on the side opposite to insertion.



Fit the pipe (31) with clip (32) in the relevant union of the blow-by box.

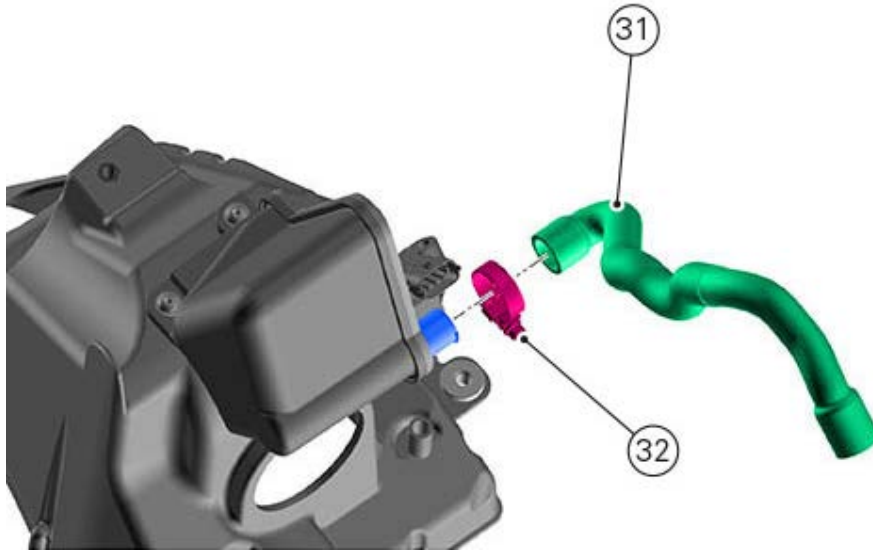

Aim hose (31) and the clip as shown in the figure.
Tighten the clip to a torque of $1.5 \text{ Nm} \pm 10\%$.

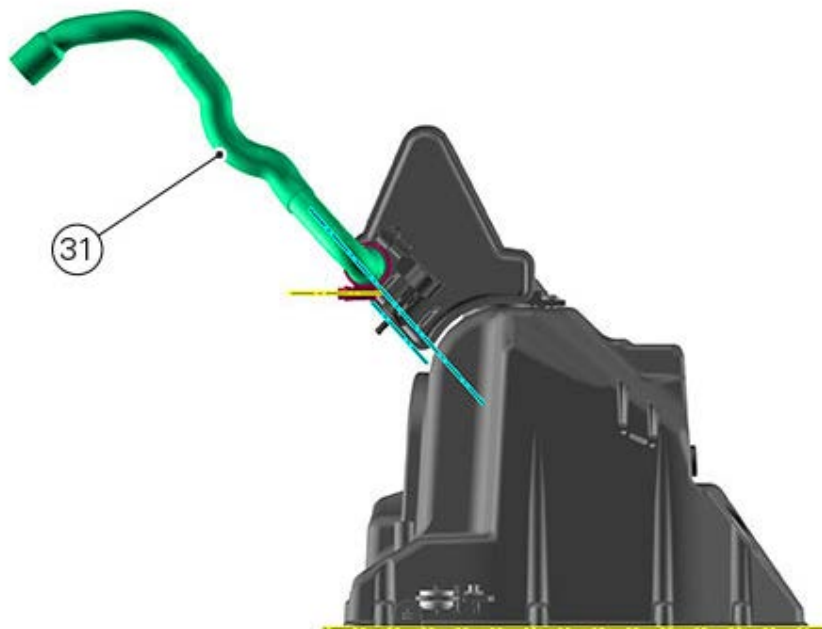

Fit seal (33) onto air temperature sensor (34).

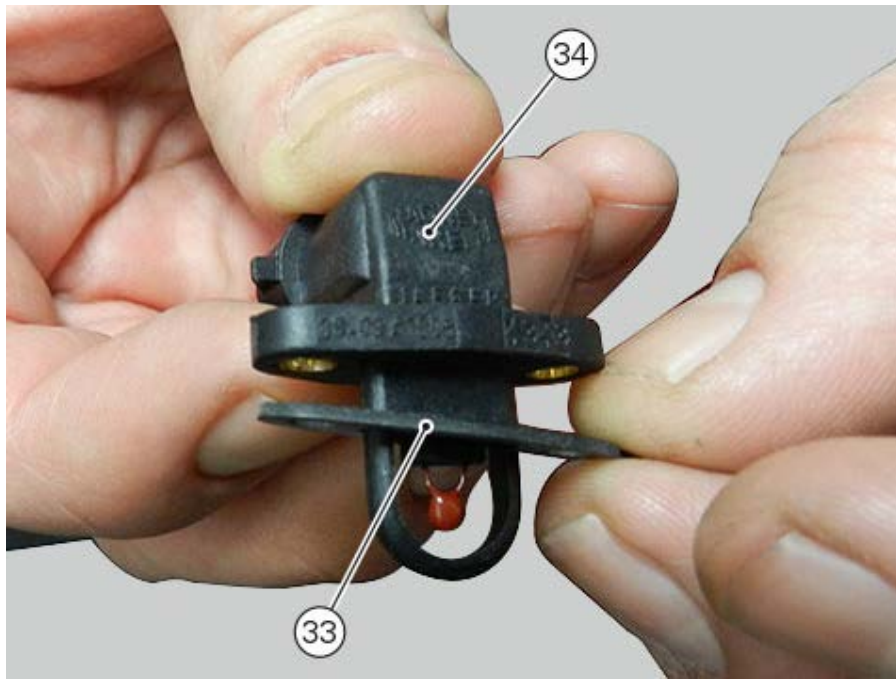

Fasten sensor (34) to the airbox and tighten the two screws (35) to a torque of $1 \text{ Nm} \pm 10\%$.

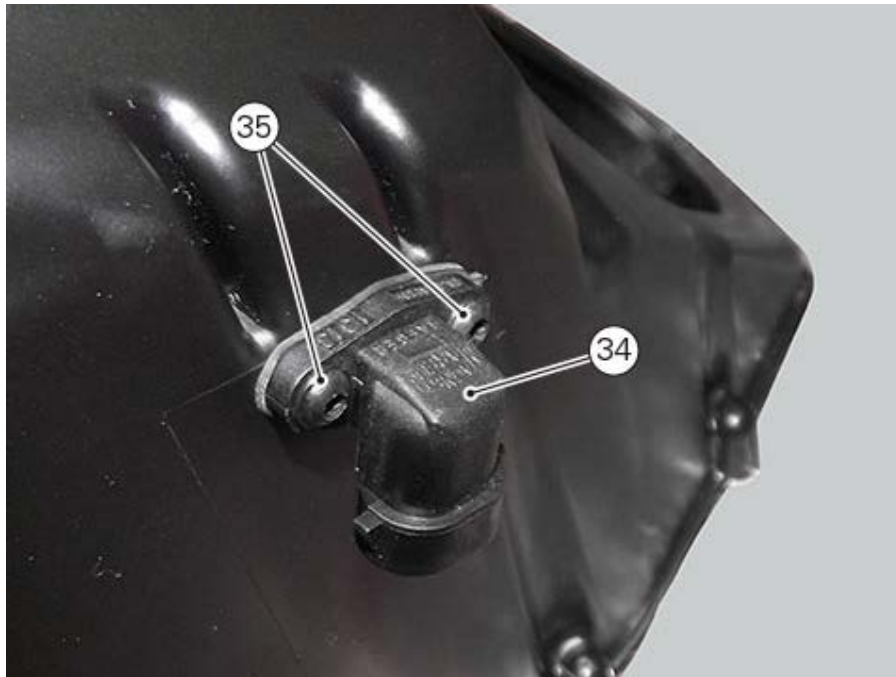

Fit hose (36) fully home on the Airbox by inserting edge (37) fully inside the recess.

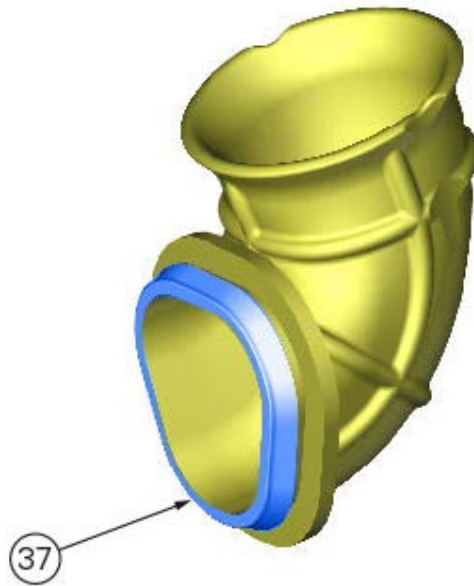
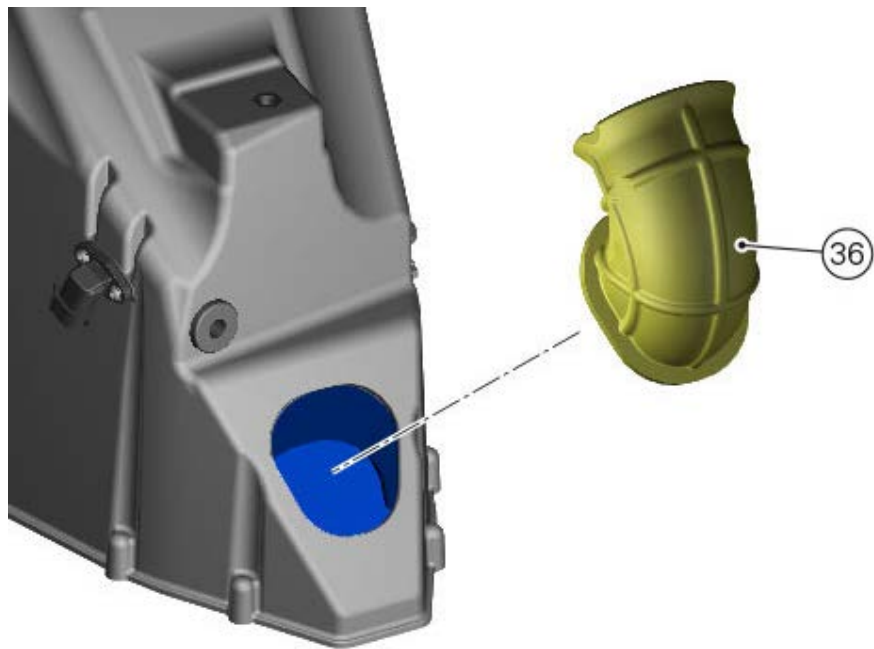

Insert the throttle body in the airbox and tighten clip (16) to a torque of $1.5 \text{ Nm} \pm 10\%$.
Position the airbox in the frame and fix it by tightening screws (17) to a torque of $10 \text{ Nm} \pm 10\%$.

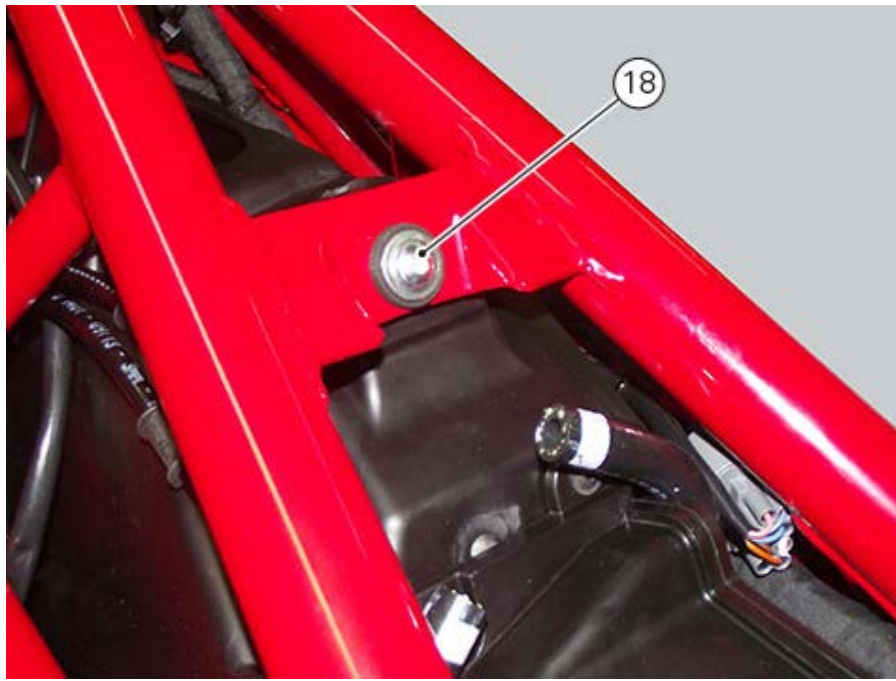

Ensure that gasket (41) is present on the airbox.

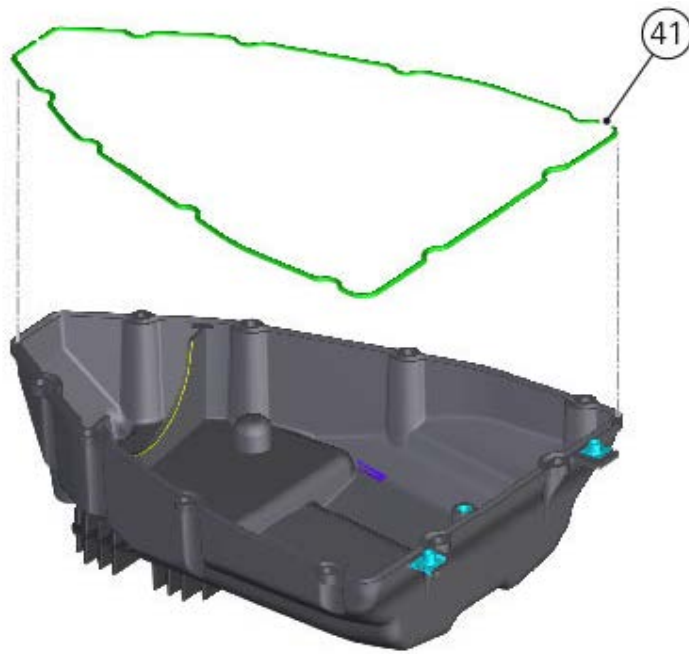

If removed, fit the voltage regulator (40) and tighten screws (29) to a torque of $10 \text{ Nm} \pm 10\%$.



Connect the MAP-SENSOR connector (17).



Connect STEPPER motor (13) and potentiometer (14).
Route the cables through the hose guide (15).

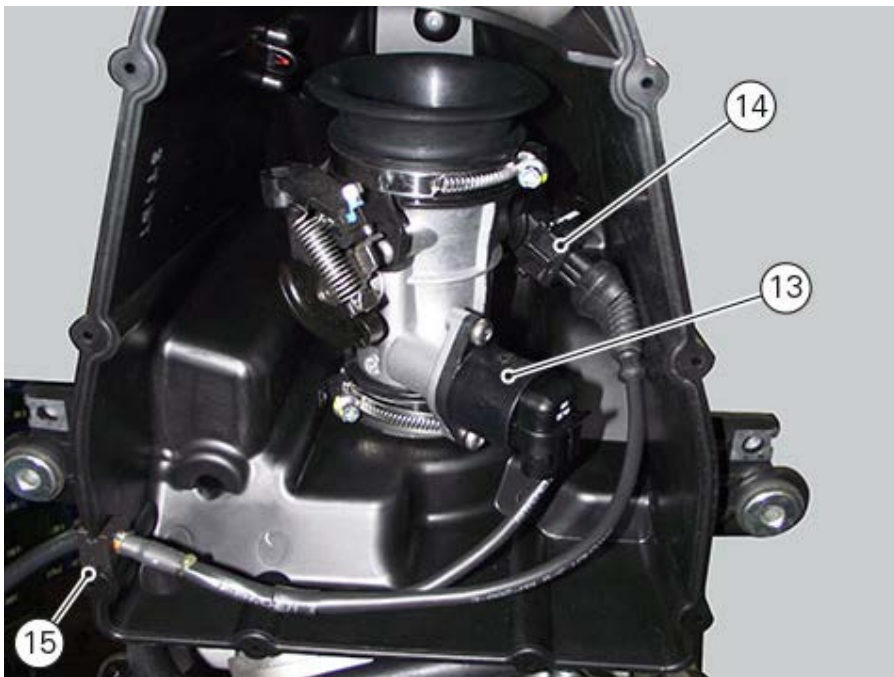

Secure the throttle body with clamp (16).



Connect throttle cable (12).



Check that air sensor (43) fits the support (42).
Install the air filter as described in paragraph "[Refitting the air filter](#)".

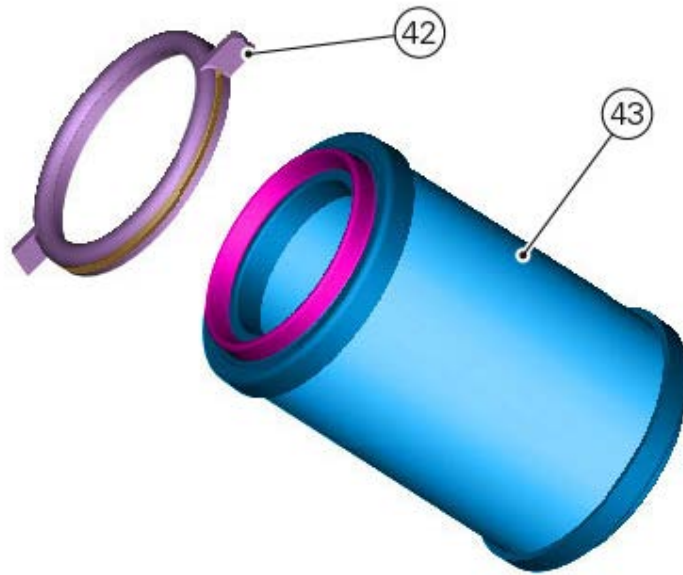

Connect the regulator connectors.





Connect air connector.



Connect the secondary air system connector (6), connect the secondary air hose (8) and tighten clip (7).

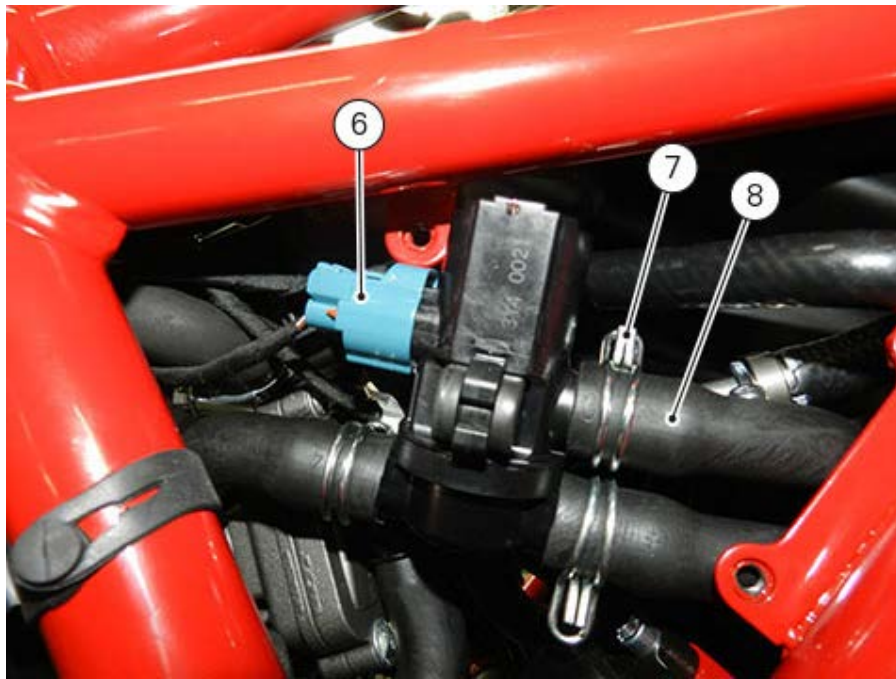

Connect connector (5) of stepper motor and potentiometer.

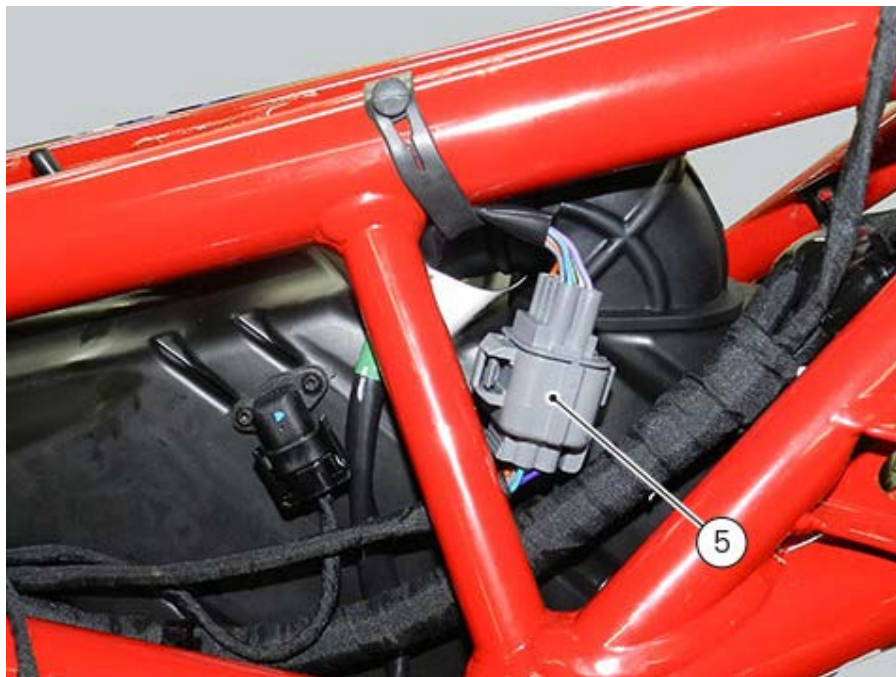

Position the side body panel so that the two pins (17) of the internal side (15) engage in seats (18).

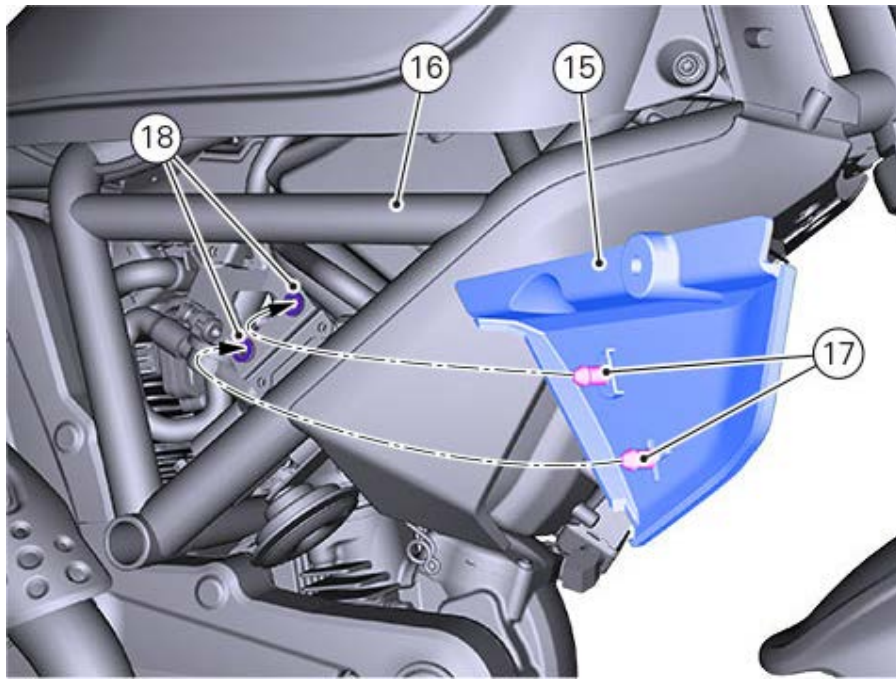

Secure side body panel (1) by tightening screw (2).
Repeat this procedure on the vehicle opposite side.

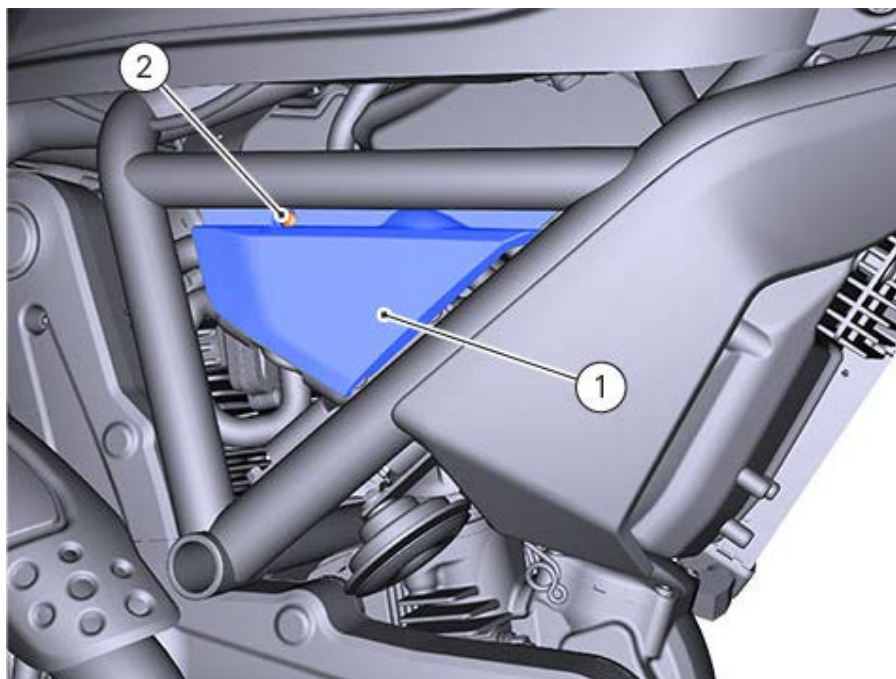

Remove the side body panels ([Fitting the airbox cover](#)).
Remove the fuel tank ([Refitting the fuel tank](#)).
Remove the seat ([Refitting the seat](#)).

Airbox cover assembly

RH airbox cover

Position the RH airbox cover (5) so that the upper end is under the tank cover (B).
Start the upper retaining screw (4) of the RH airbox cover (5) and the lower screws (6) with the relevant washers.
Tighten screws (6) to a torque of $8 \text{ Nm} \pm 10\%$ and screw (4) to a torque of $5 \text{ Nm} \pm 10\%$.

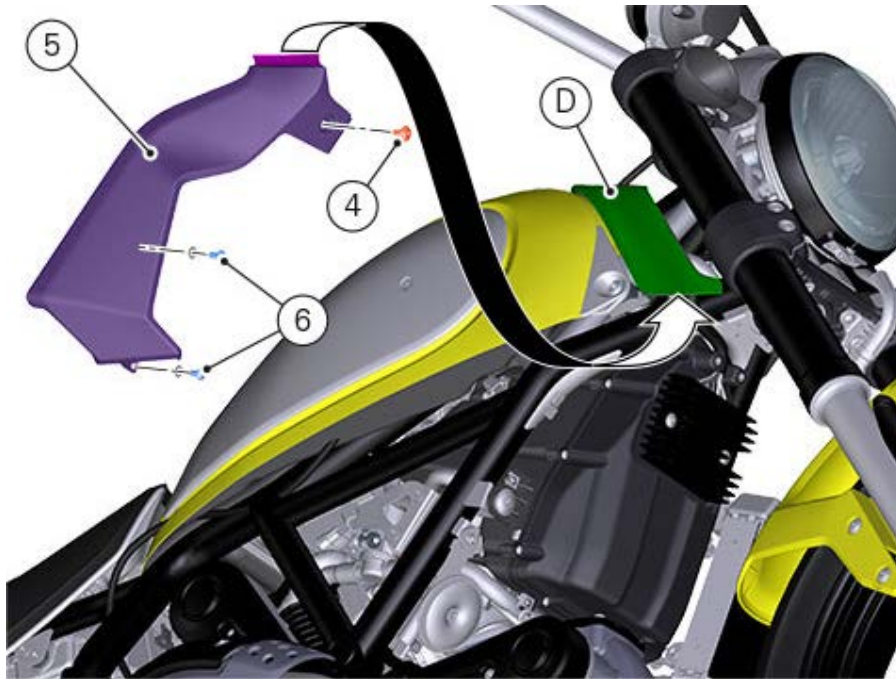
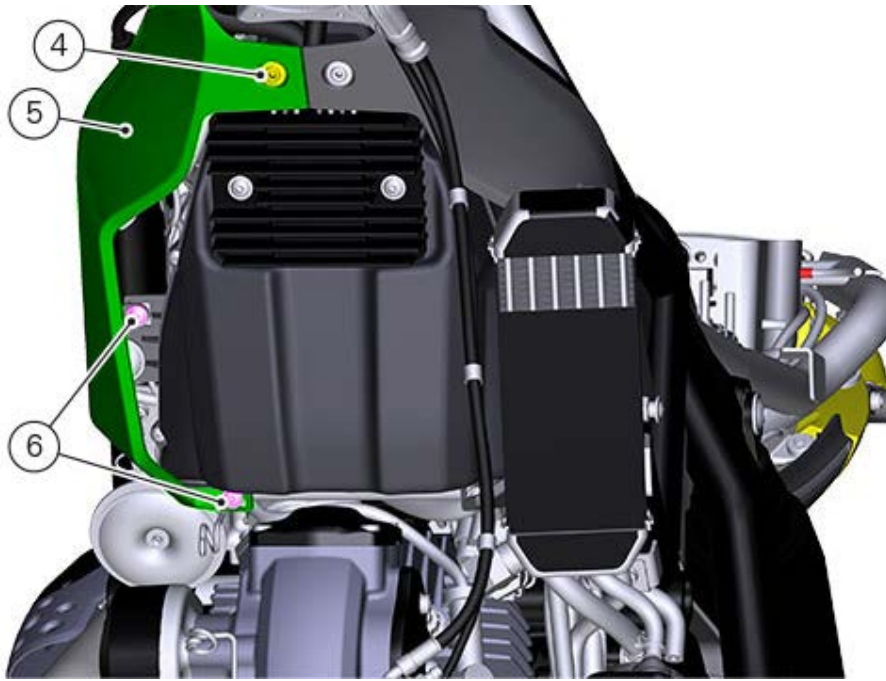

LH airbox cover

Position the LH airbox cover (7).

Start the upper retaining screw (4) of the LH airbox cover (7) and the lateral screws (8).

Tighten the screws (4) to a torque of $5 \text{ Nm} \pm 10\%$ and the screws (8) to a torque of $5 \text{ Nm} \pm 10\%$.

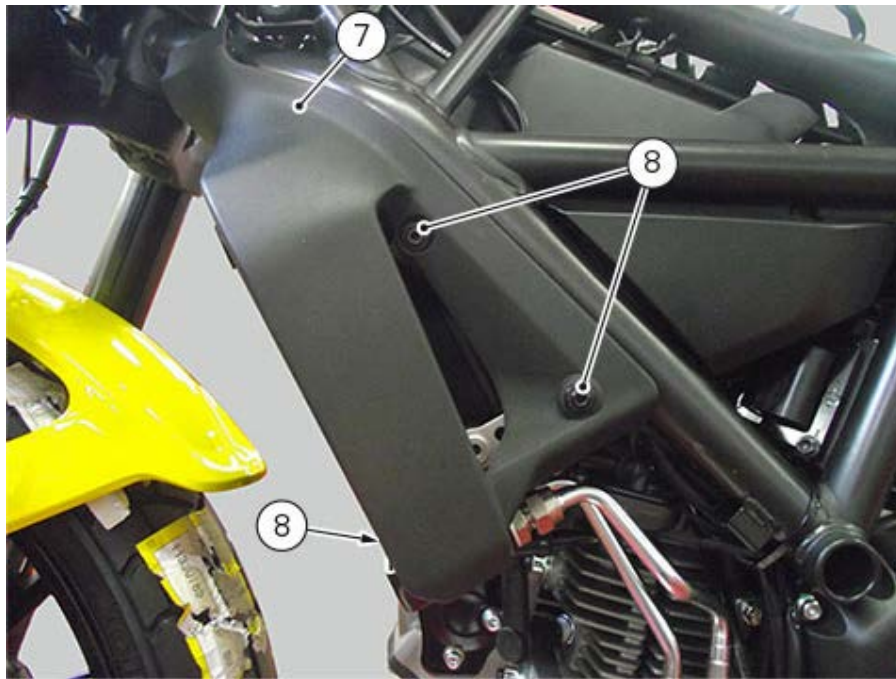

Removing the airbox

Remove the seat ([Removing the seat](#)).

Remove the fuel tank ([Removing the fuel tank](#)).

Remove the side body panels ([Removing the airbox cover](#)).

Remove side body panels (1) and (3) loosening screws (2) and (4).

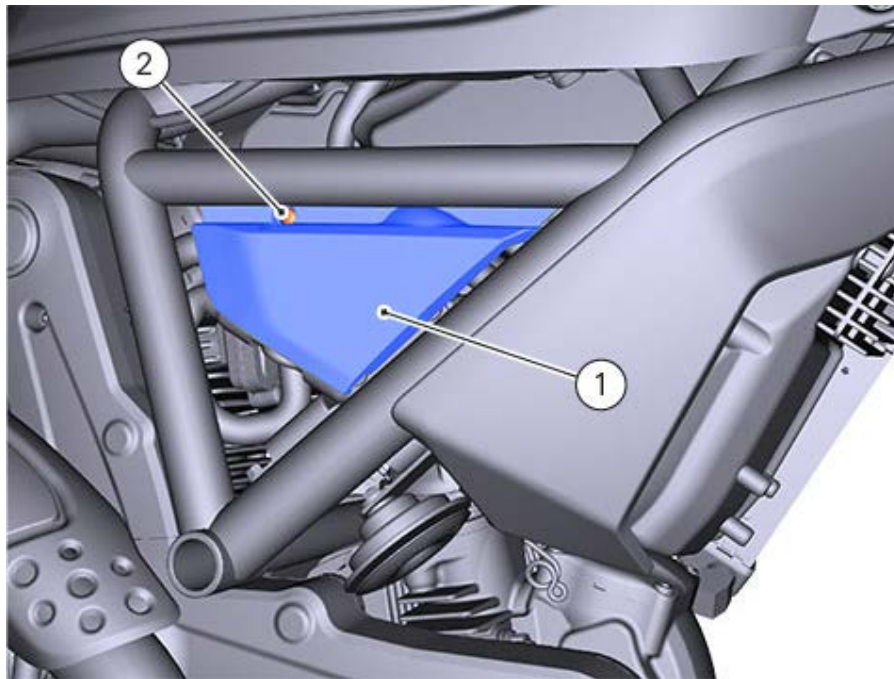

Disconnect connector (5) of stepper motor and potentiometer.

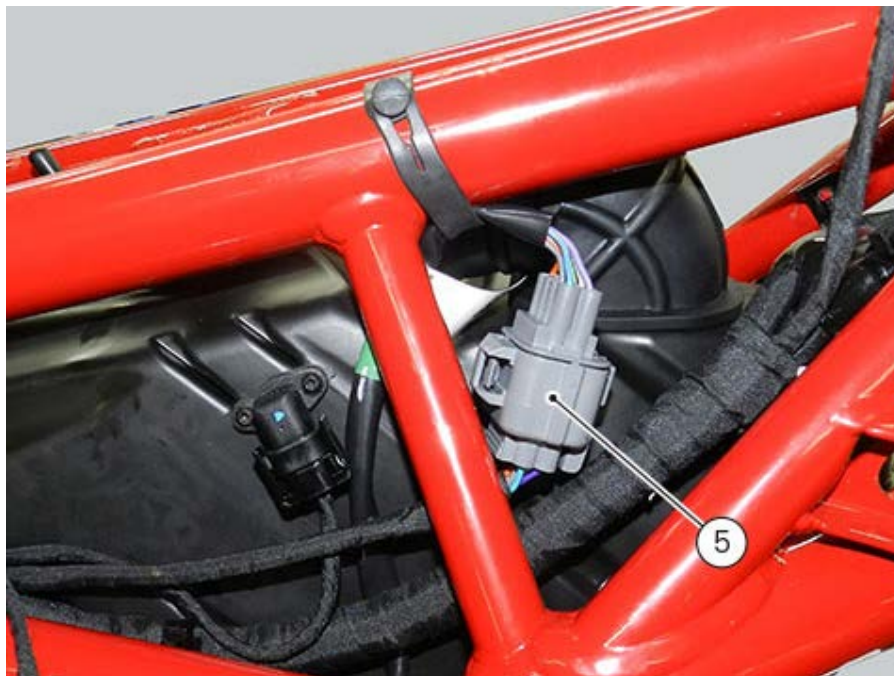

Disconnect the secondary air system connector (6), loosen clip (7) and disconnect the secondary air system hose (8).

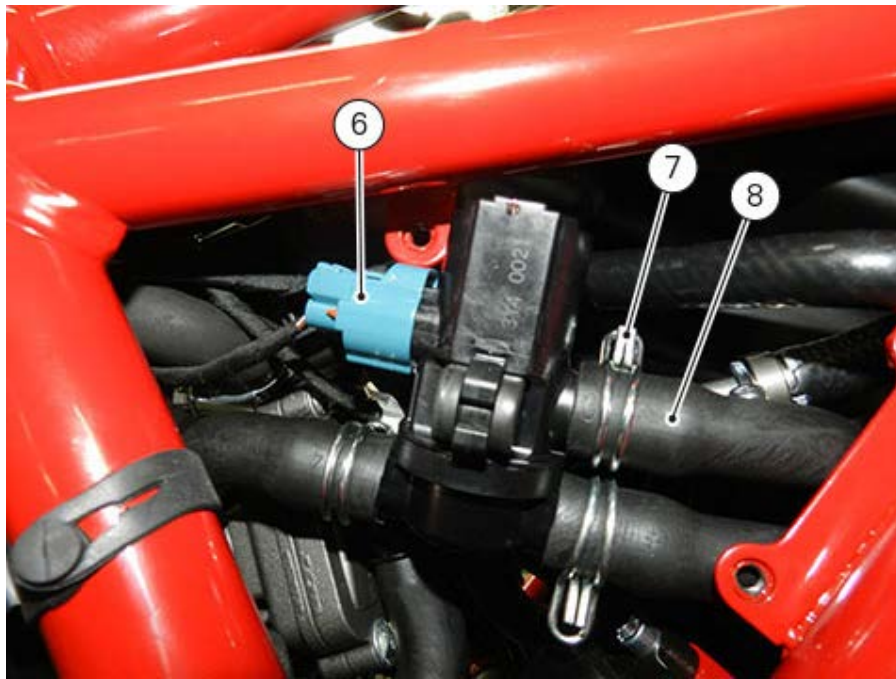

Disconnect air connector.



Disconnect the regulator connectors.



Undo screws (11) and remove the airbox cover (10).

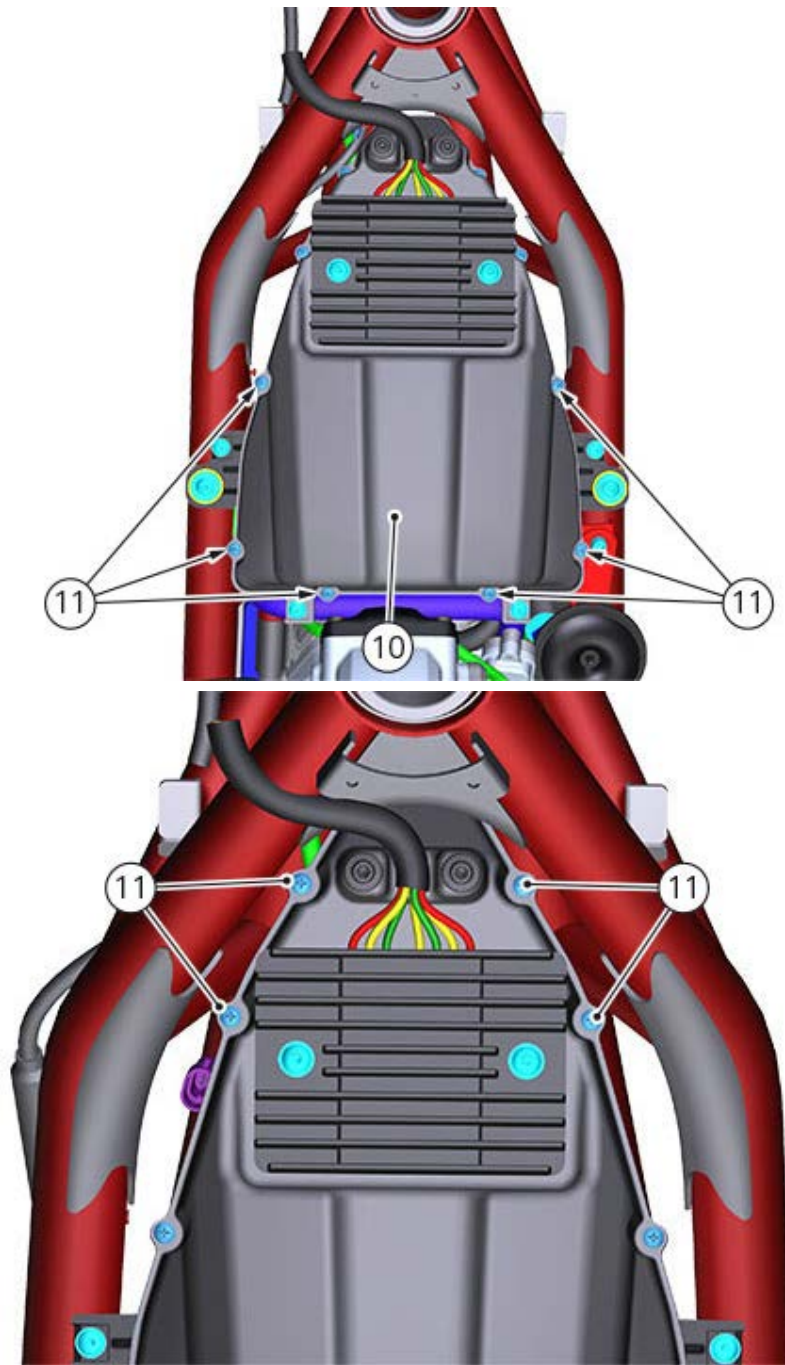

Disconnect throttle cable (12).



Loosen clip (16).



Disconnect STEPPER motor (13) and potentiometer (14).
Release the cables from the airbox by sliding out hose guide (15).

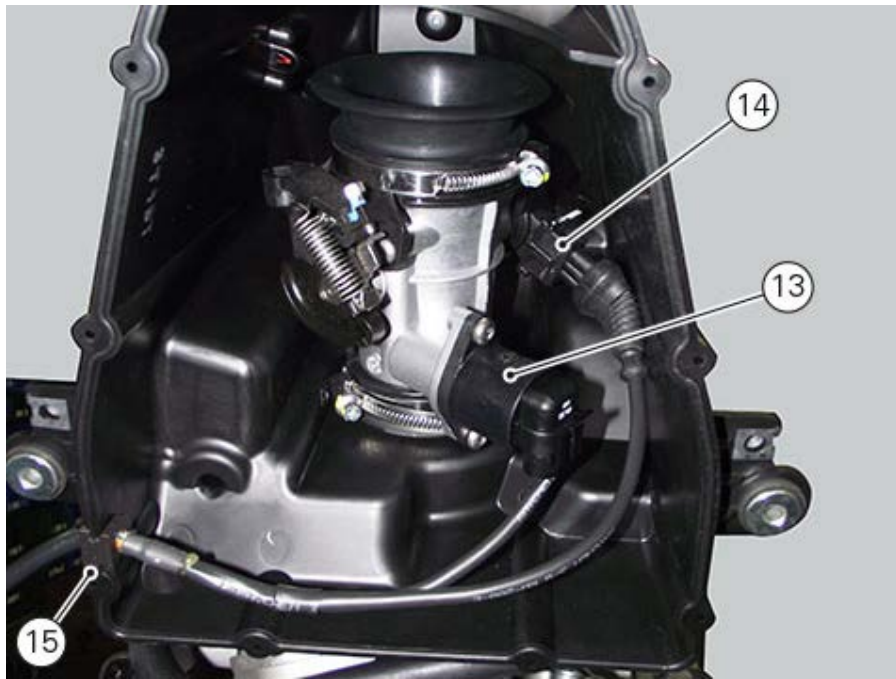

Disconnect the MAP-SENSOR connector (17).



Remove the ties that can obstacle the airbox removal.
Remove the airbox with the throttle body by loosening the screws (18).



Removing the airbox cover

RH cover

Loosen the upper retaining screw (4) of the RH airbox cover (5) and the lower screws (6).
Remove the RH airbox cover (5).

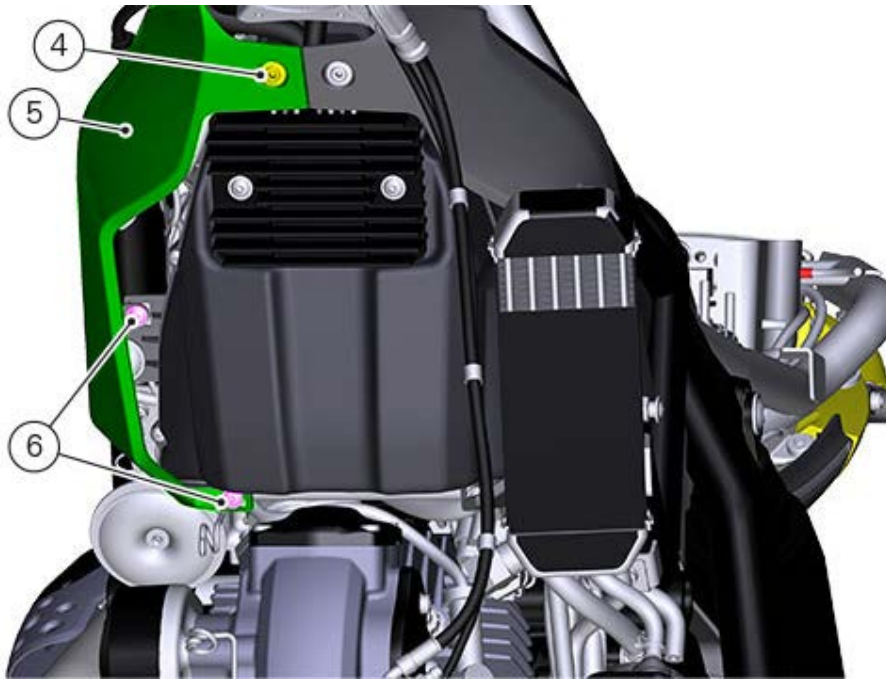

LH cover

Loosen the upper screw (4) of the LH airbox cover (7), the lateral and lower screws (8). Remove the LH airbox cover (7).



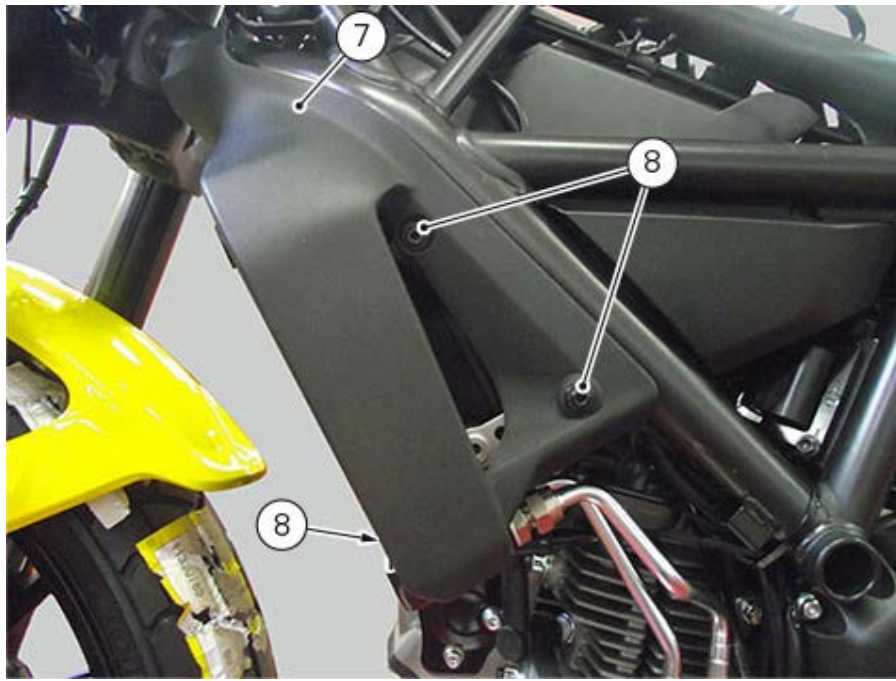

Refitting the secondary air system

Remove the previously inserted cloth from the duct.

Warning

Do not invert the positions of the covers and components of the two valves of the secondary air system. Refer to the reference notches present on the secondary air system valve cover and on head cover.

If disassembled, refit the secondary air system valves following the procedure described below. Fit the retaining screw (15) in the secondary air system base (14).

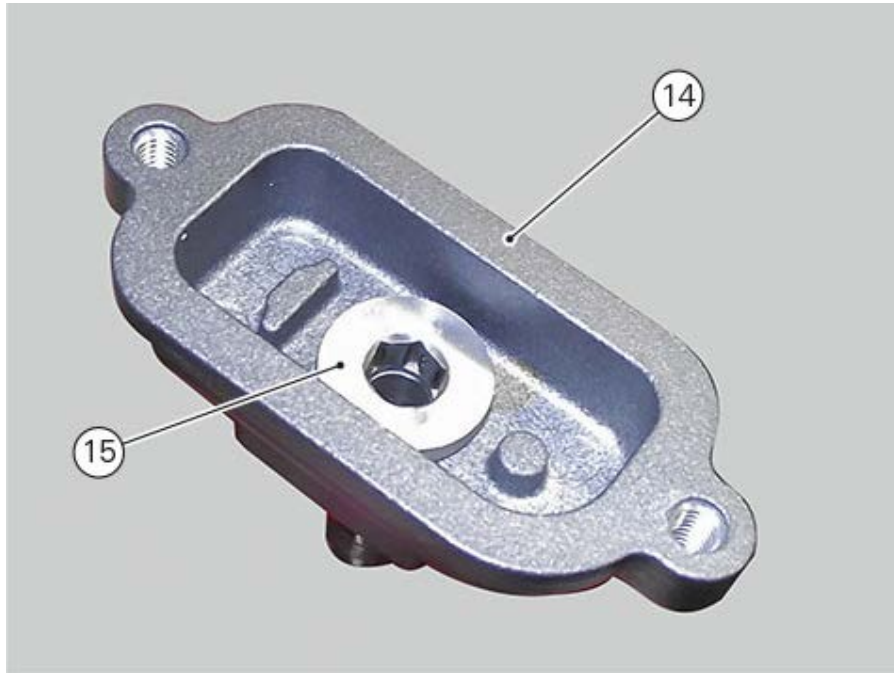

Working on the opposite side, install O-ring (16) as shown in the figure.



Position the secondary air system base on the cylinder head and apply indicated threadlocker to screw (15). Tighten screw (15) to a torque of 15 Nm (Min. 13 - Max. 17).

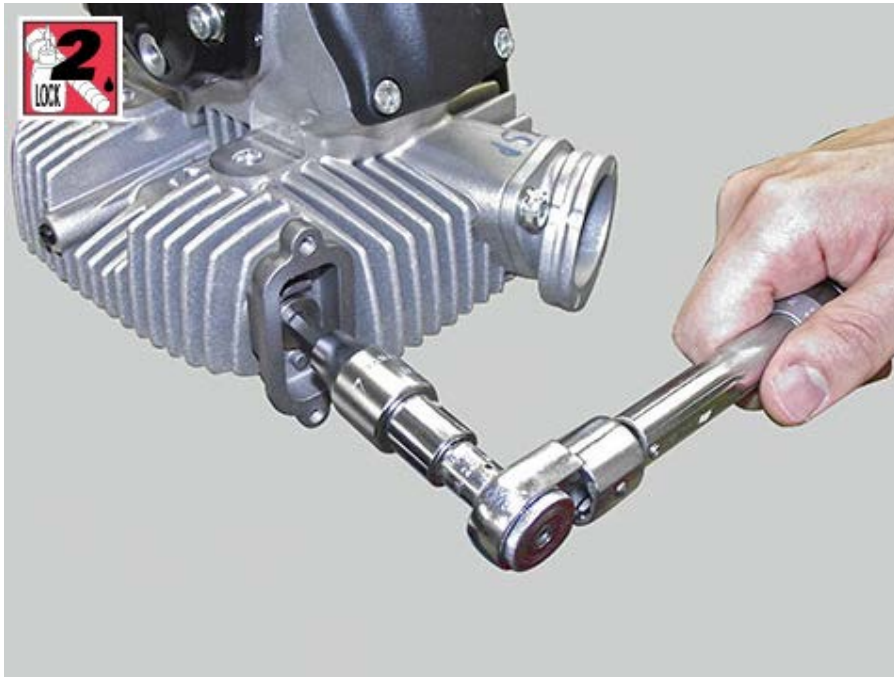

Position the spark arrester plate (13) and pay attention to the insertion direction.



Fit the reed valve (12) on cover (11).



Position the secondary air system cover (11) on the vertical and horizontal cylinder head cover, as shown in the figure.
Tighten the screws (17) to a torque of 6 Nm (Min. 5 - Max. 7).

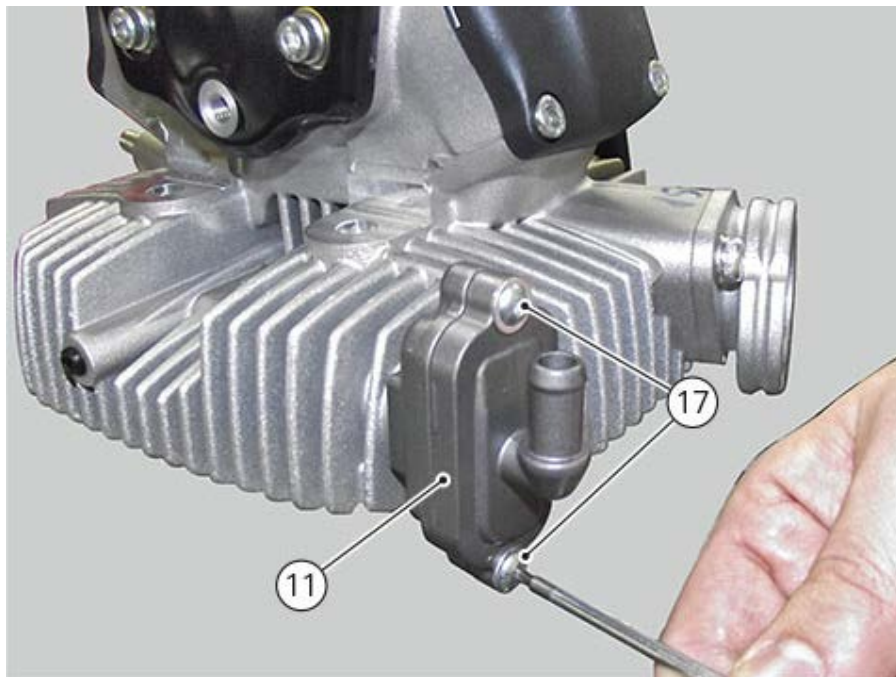

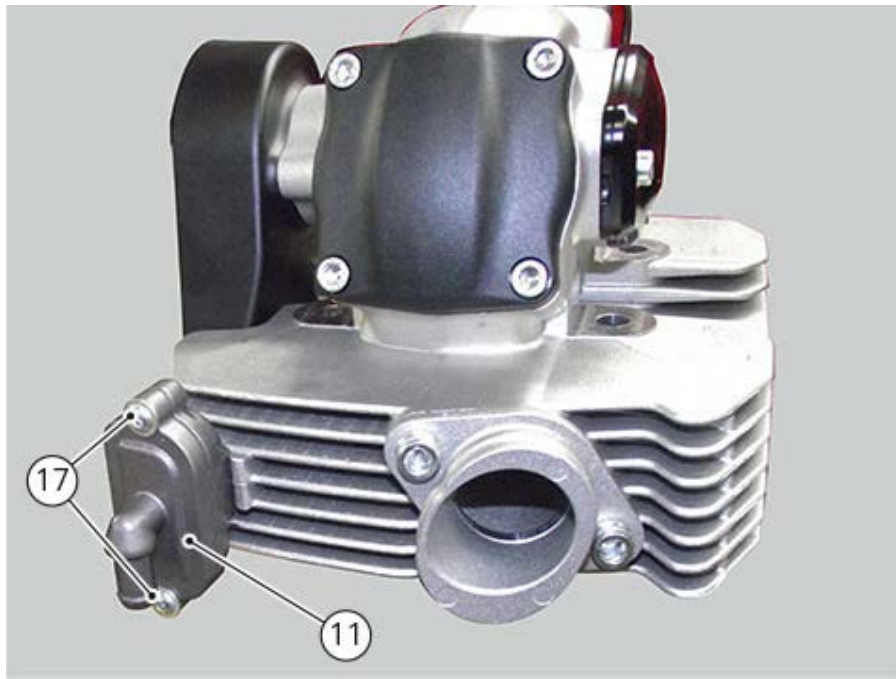

Working on the vertical head, position hose (5) as shown in the figure and fix it with clip (8).

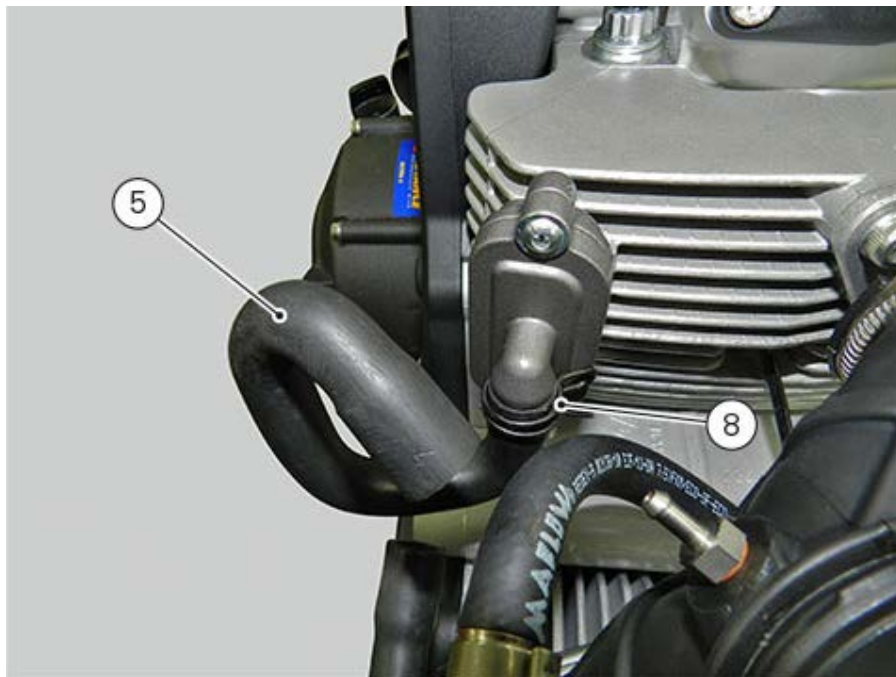

Repeat the operation on the horizontal cylinder head, orienting hose (6) as shown in the figure and fixing it with clip (9).

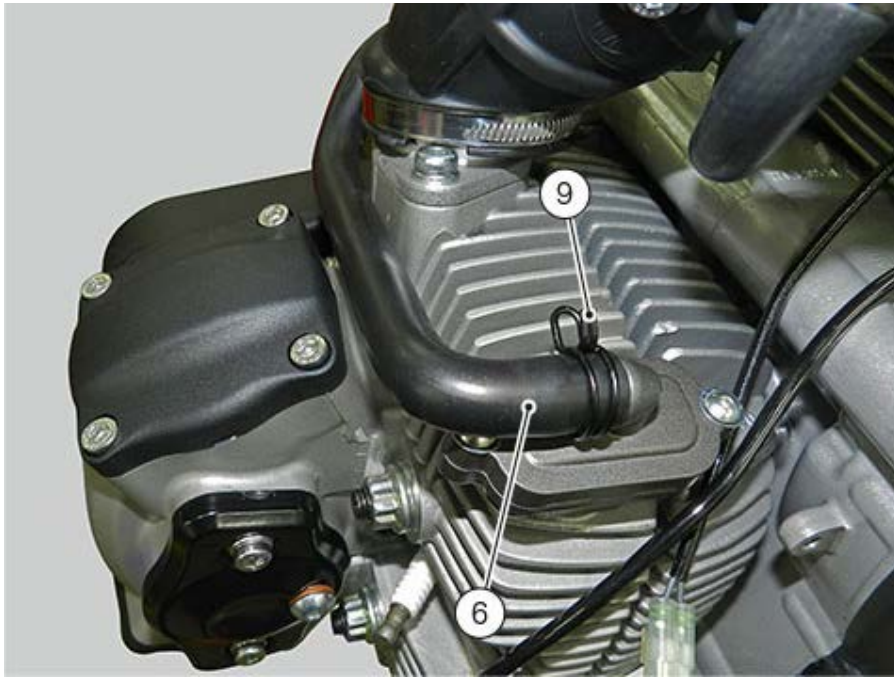

If previously removed, connect hose (7) to the airbox as shown and fix it with the suitable clip.



Connect the secondary air system sensor to the vertical head through hose (5); repeat the operation with the horizontal cylinder head hose (6) and hose (7) coming from the airbox. Fix the three hoses with clips (4). Connect the secondary air sensor connector (3).

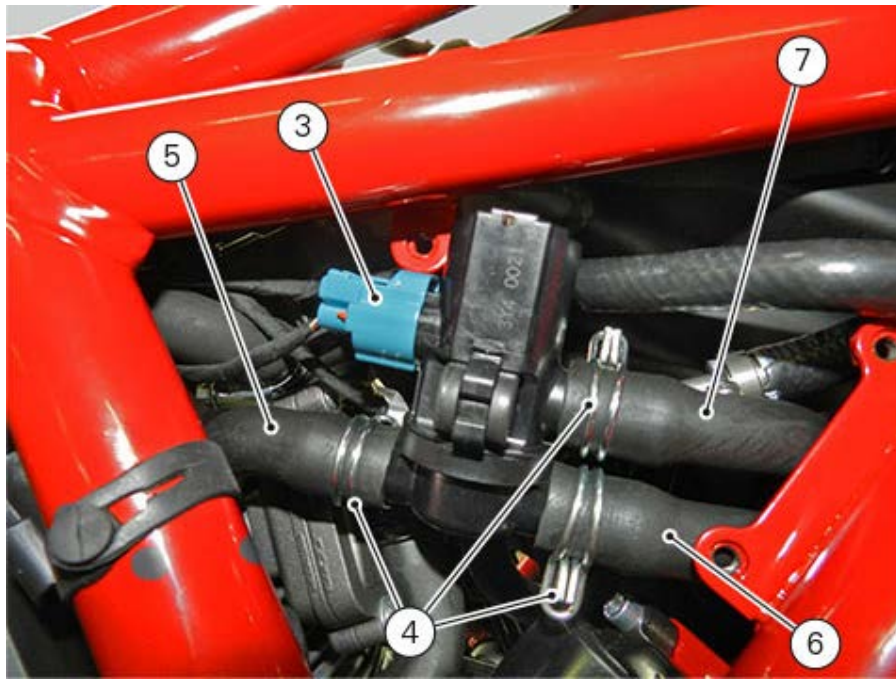

Fit the lateral cover so that pins (17) engage in their seat (18).

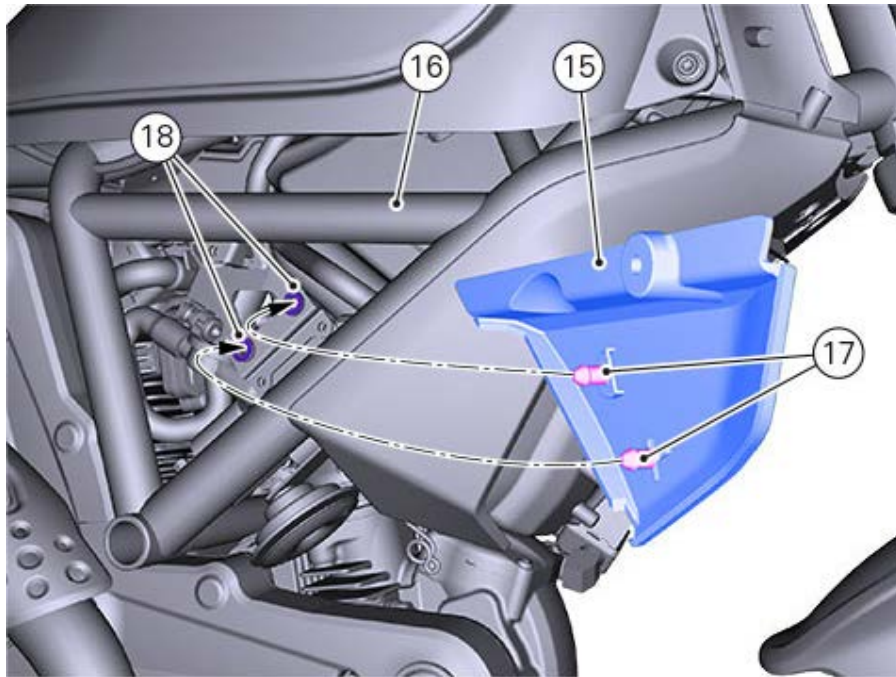

Tighten the screw (2) to a torque of $5 \text{ Nm} \pm 10\%$.

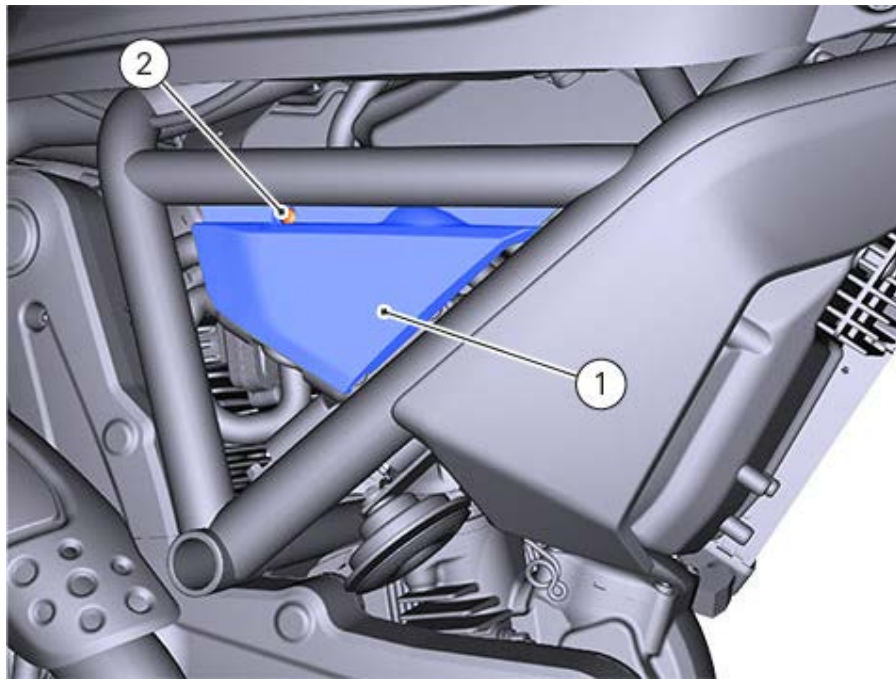

Removing the secondary air system

Remove the seat ([Removing the seat](#)).

Remove the fuel tank ([Removing the fuel tank](#)).

Remove the lateral cover (1), loosening screw (2).

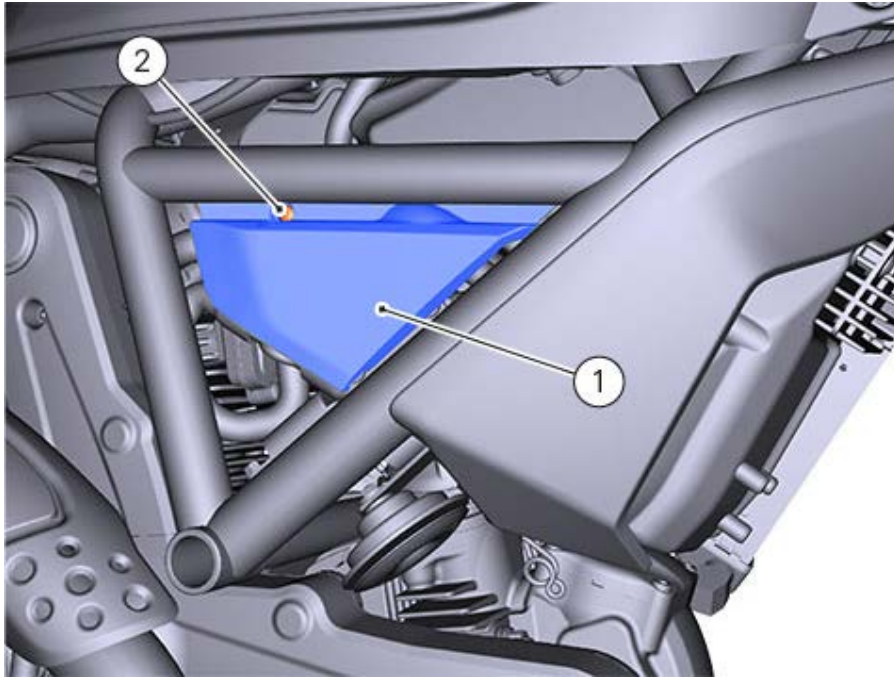

Disconnect connector (3) of the secondary air system.

Remove clips (4) and disconnect vertical cylinder pipe (5), horizontal cylinder pipe (6) and airbox pipe (7).

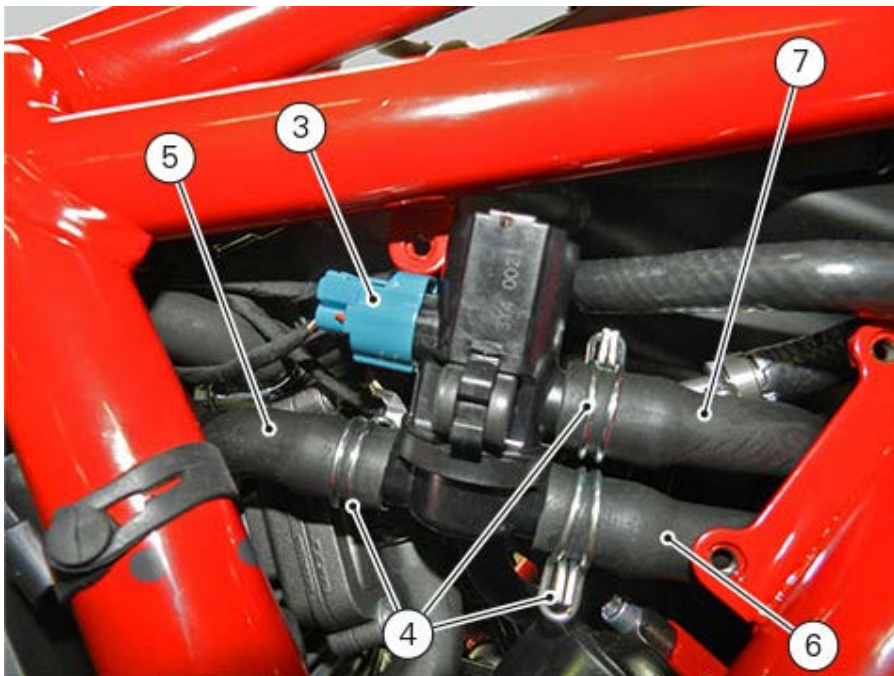

For a better understanding, the image below refers to an engine removed from the frame.

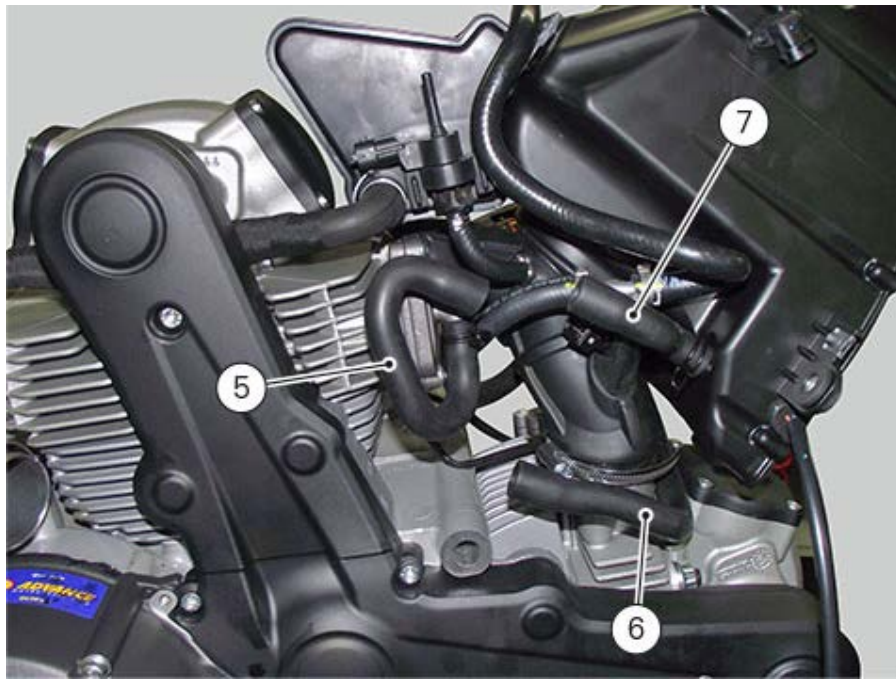

Work on the vertical head and remove clip (8) and disconnect pipe (5).

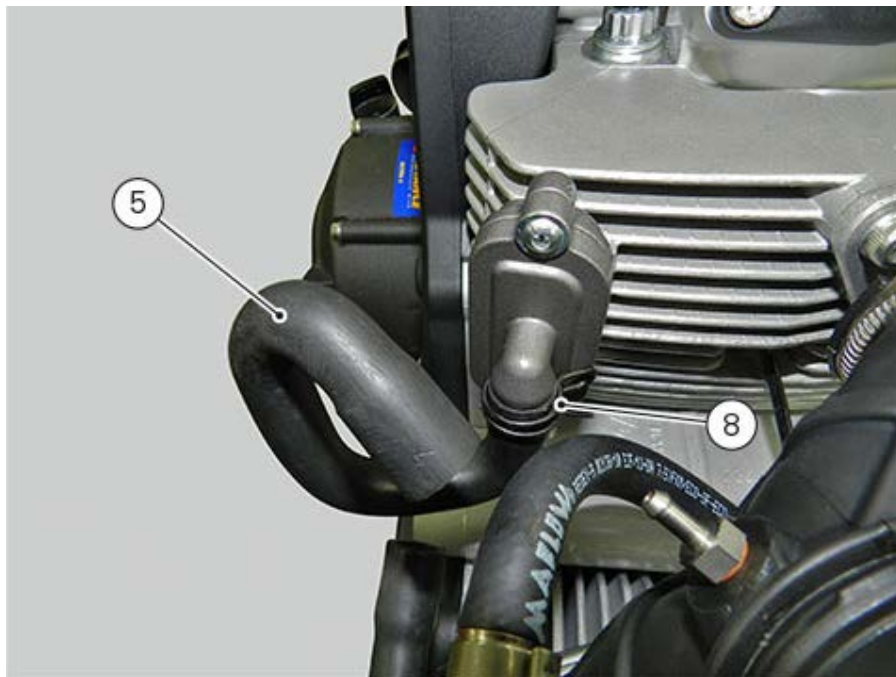

Repeat the operation on the horizontal head, removing clamp (9) and hose (6).

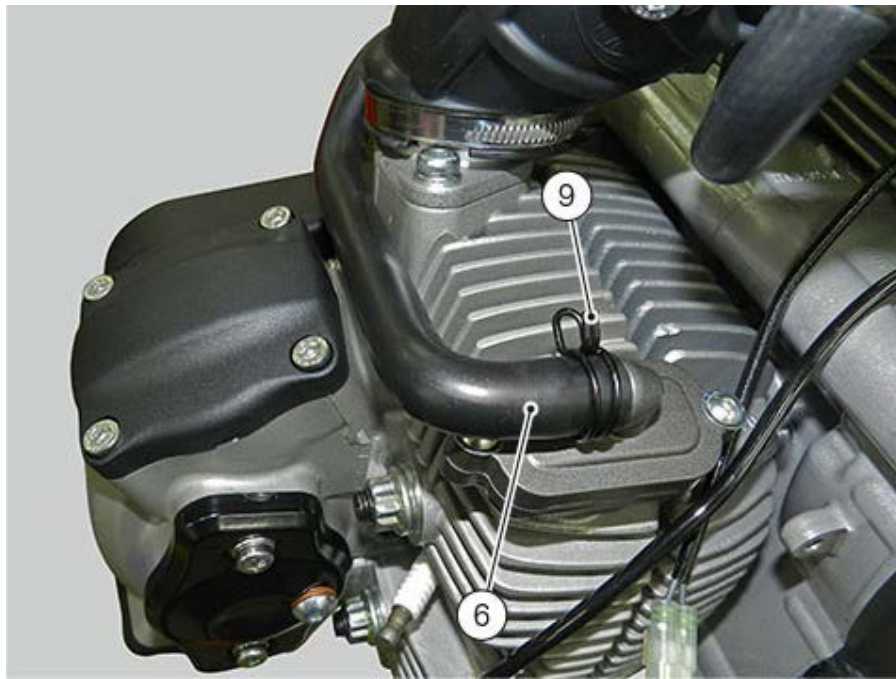

If necessary, disassemble secondary air system valves following the same procedure for both of them: Loosen the two screws (10) and slide out, in this sequence, cover (11), reed valve (12), spark arrester plate (13), secondary air plate base (14), the relevant retaining screw (15) and O-ring (16).

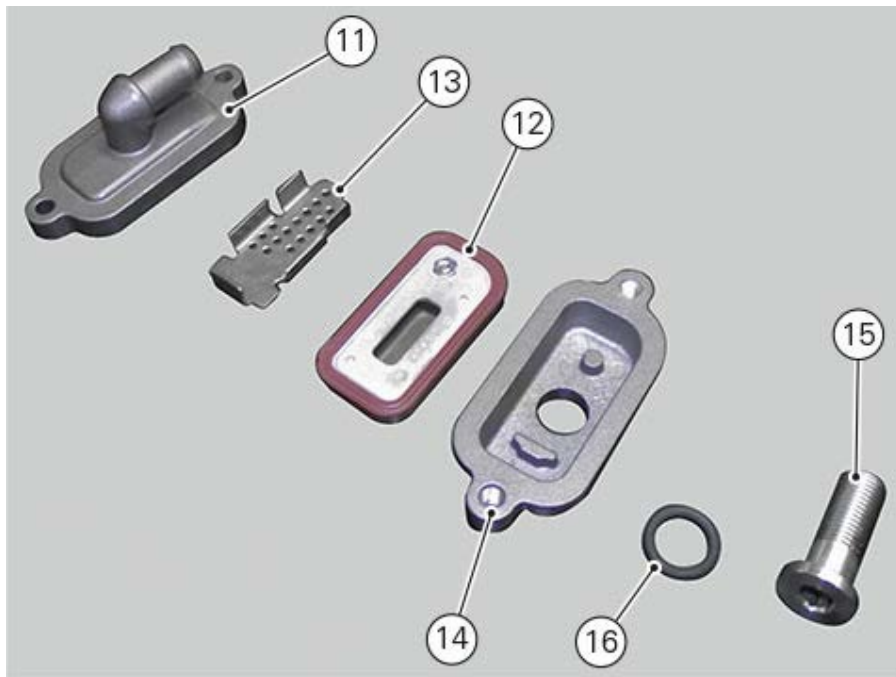

Note

block off the secondary air system duct on head cover with a clean cloth so as to avoid any impurities from entering the duct.

Refitting the air filter

If it is necessary to refit the filter cover, refer to paragraph "[Refitting the airbox](#)".

Fit the rubber support (7) on filter (6).

Fit air filter unit fully home on the relevant cover (3) by inserting the support edge (7) in the cover internal wall.



Fit the filter base (8) fully against the air filter (6).

Fix it by tightening screws (5) to a torque of $5 \text{ Nm} \pm 10\%$.

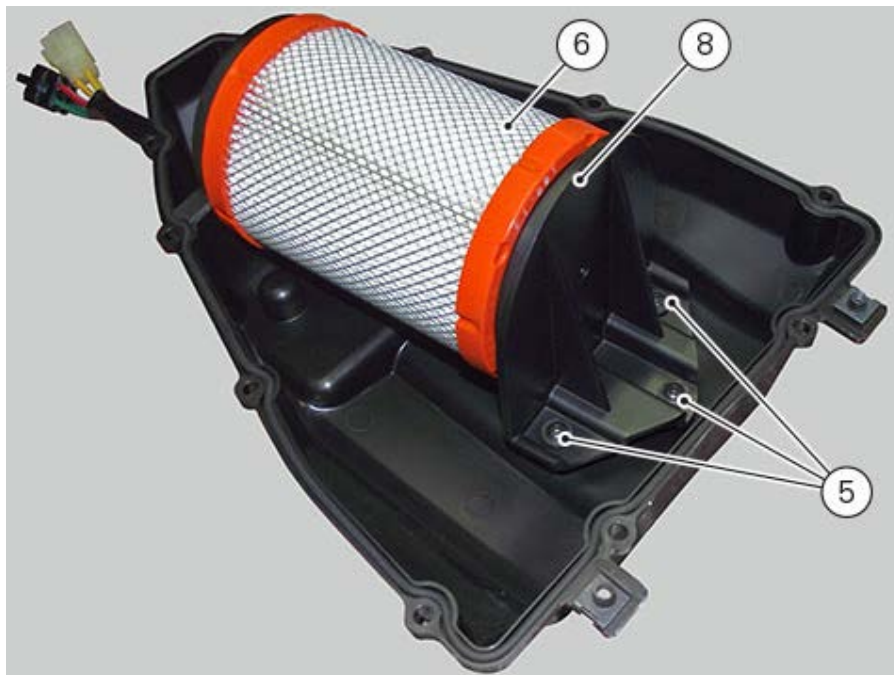

Position the air filter cover (3) and tighten screws (4) to a torque of $1 \text{ Nm} \pm 10\%$.

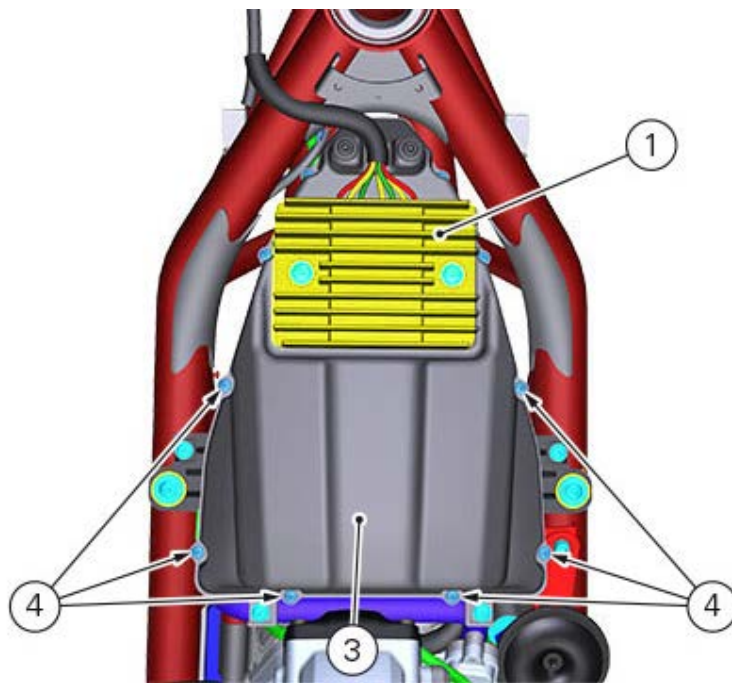
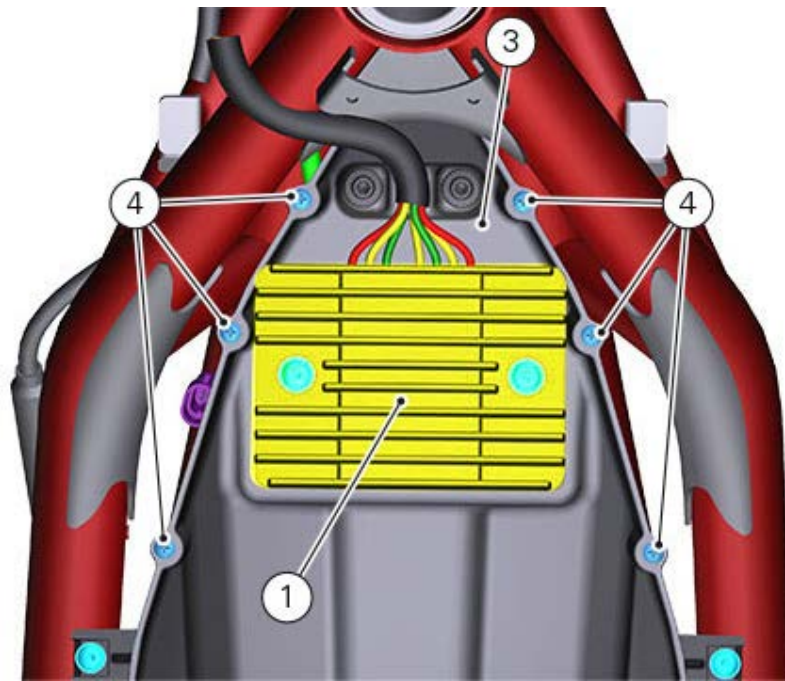

Connect the regulator connectors.



Removing the air filters

Disconnect the regulator connectors.



Undo screws (4) and remove the airbox cover (3).

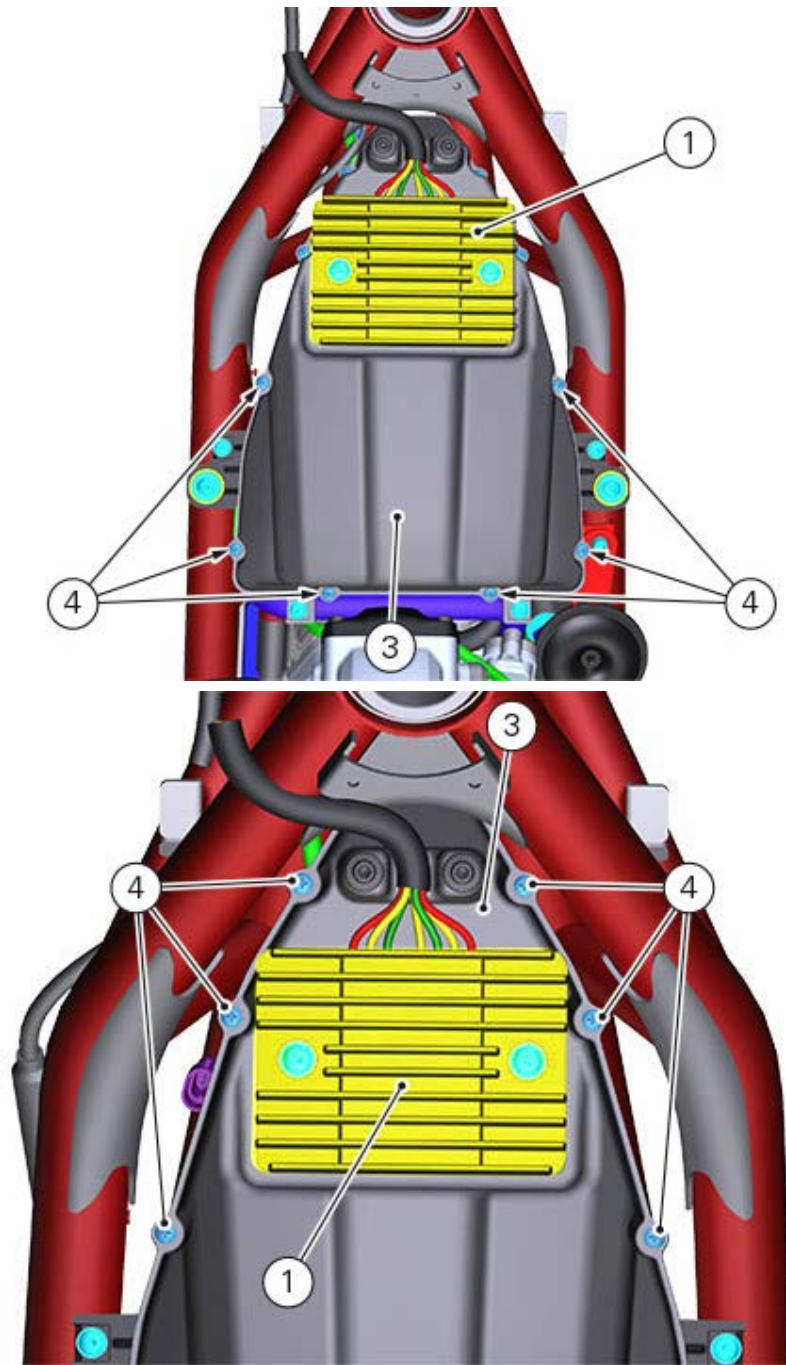

Remove the airbox cover.
Loosen the three screws (5) of the support to remove the air filter.
Remove the airbox (6).

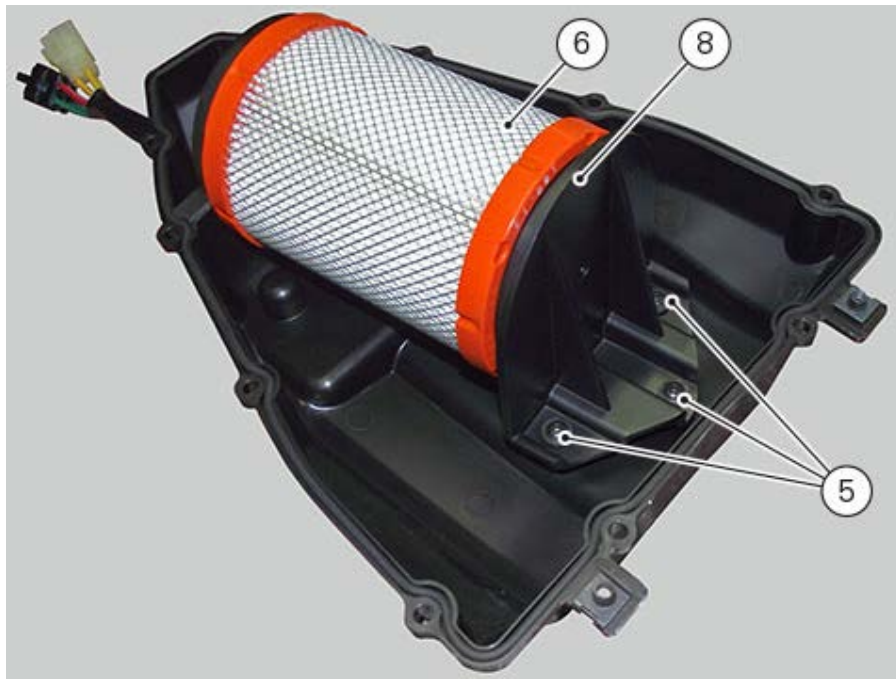

Refitting the silencer

Start and tighten screw (2) in the footpeg holder plate to a torque of $10 \text{ Nm} \pm 10\%$.

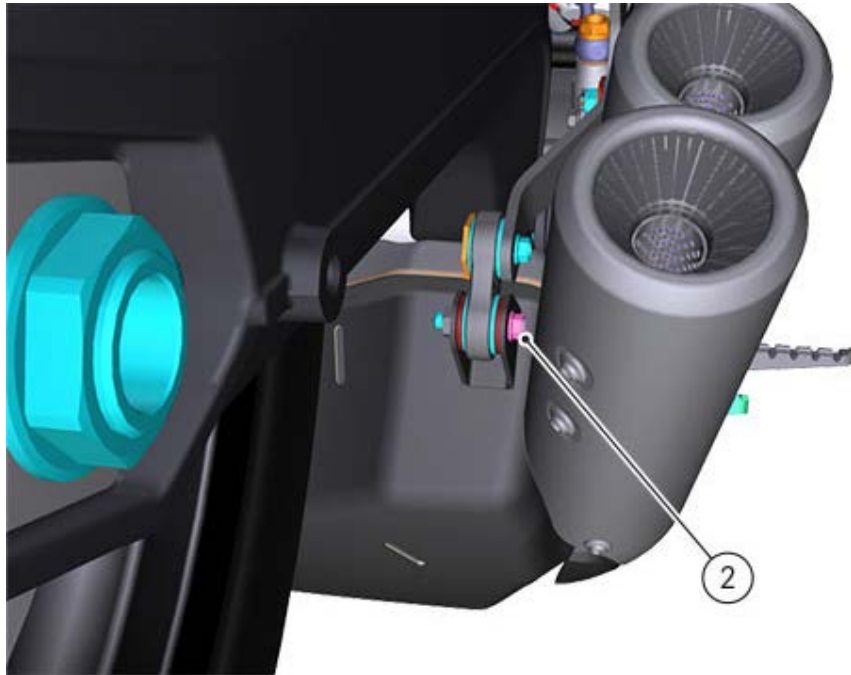

Working on vehicle left side, tighten screw (1) to a torque of $10 \text{ Nm} \pm 10\%$.

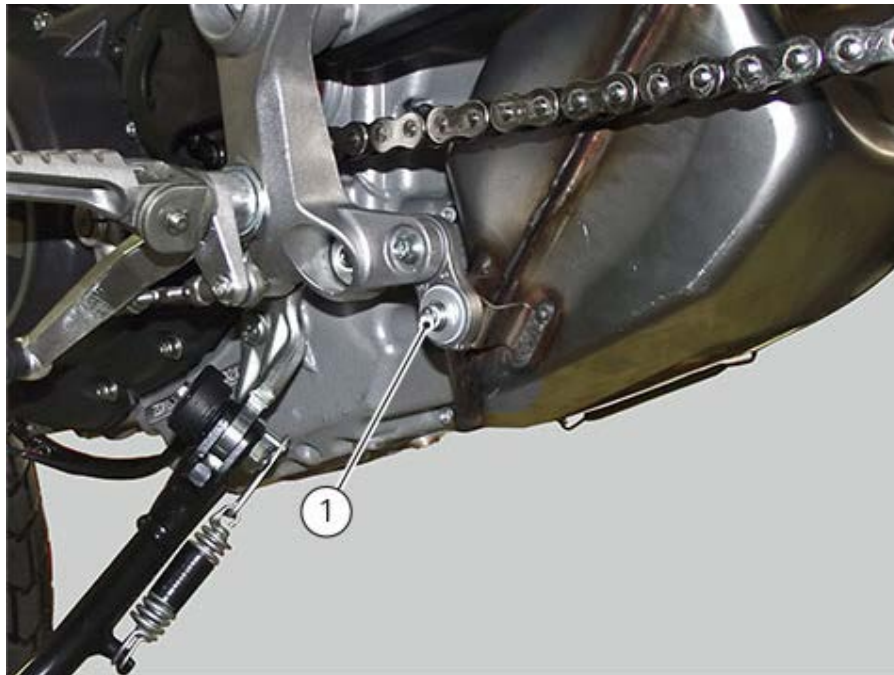

Fix the silencer to the central part of the exhaust through spring (3).

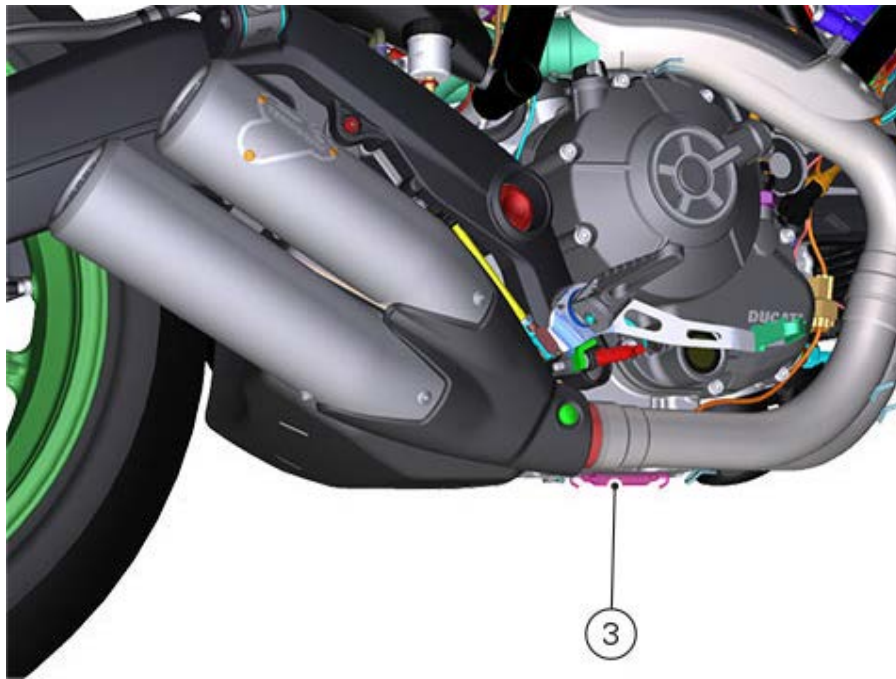

REASSEMBLING THE SILENCER

Insert the two exhaust pipes (8) fully inside the central body (9) by aligning their edge with plate (11), as shown in the figure.

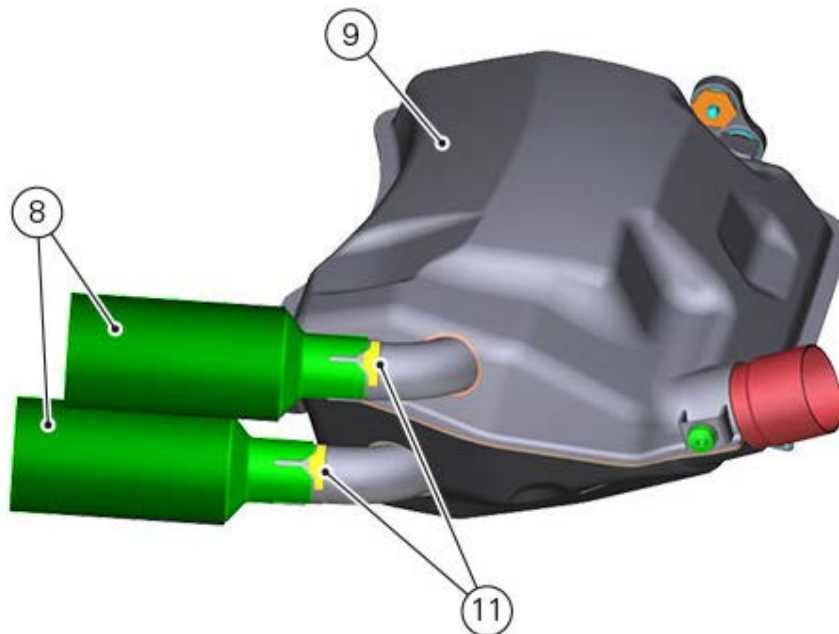

Tighten clamps (19).

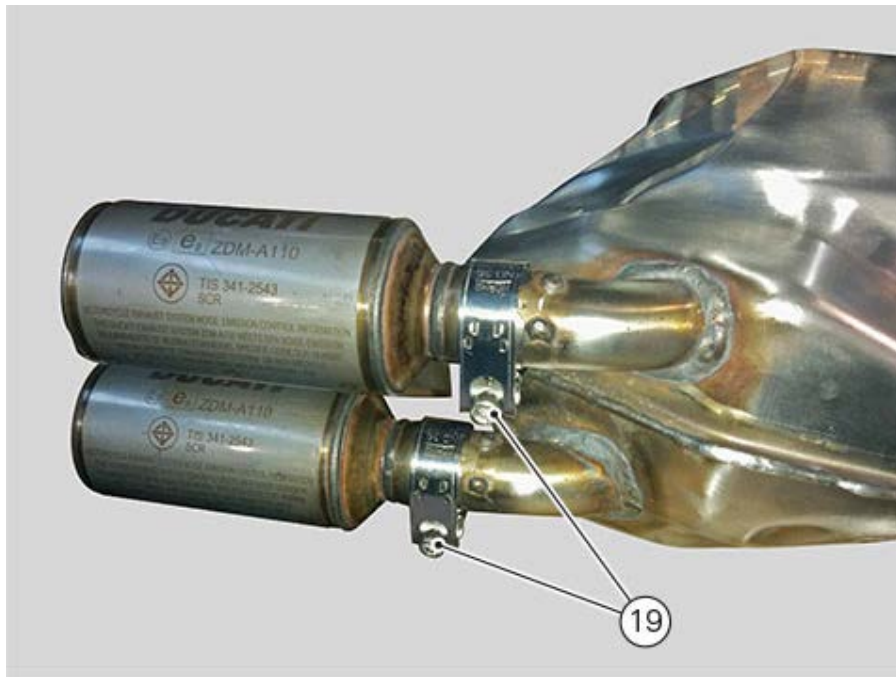

Make sure clip (12) is in place.

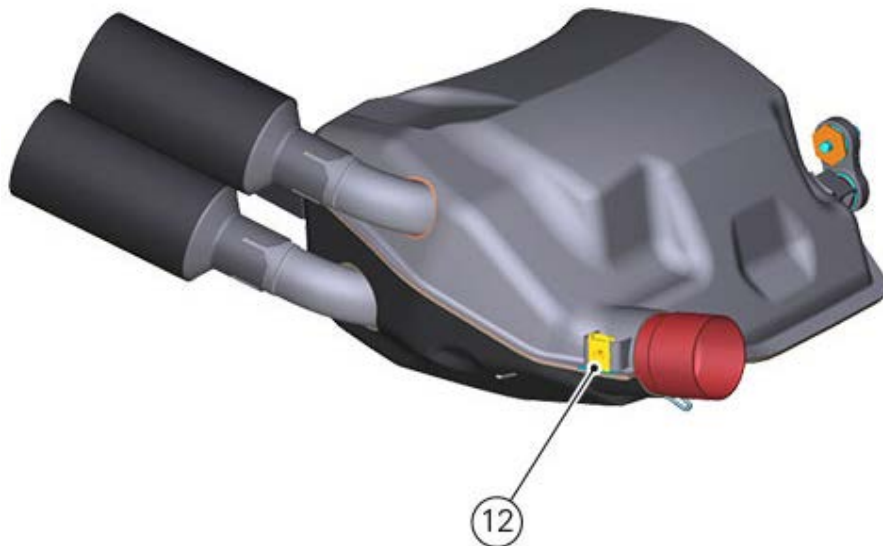

Fit the heat guard (6) with spacer (13) and washer (14).
Fix it by tightening screw (7) to a torque of $4 \text{ Nm} \pm 10\%$.
Make sure clips (16) are in place.

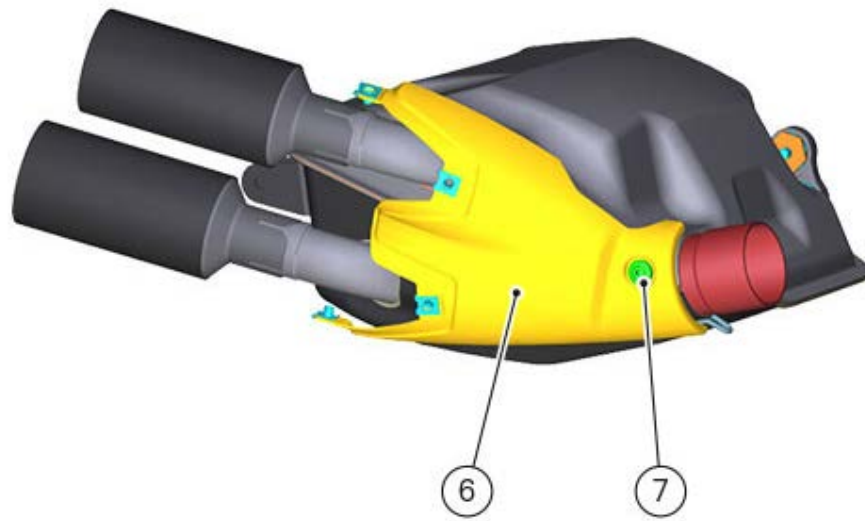
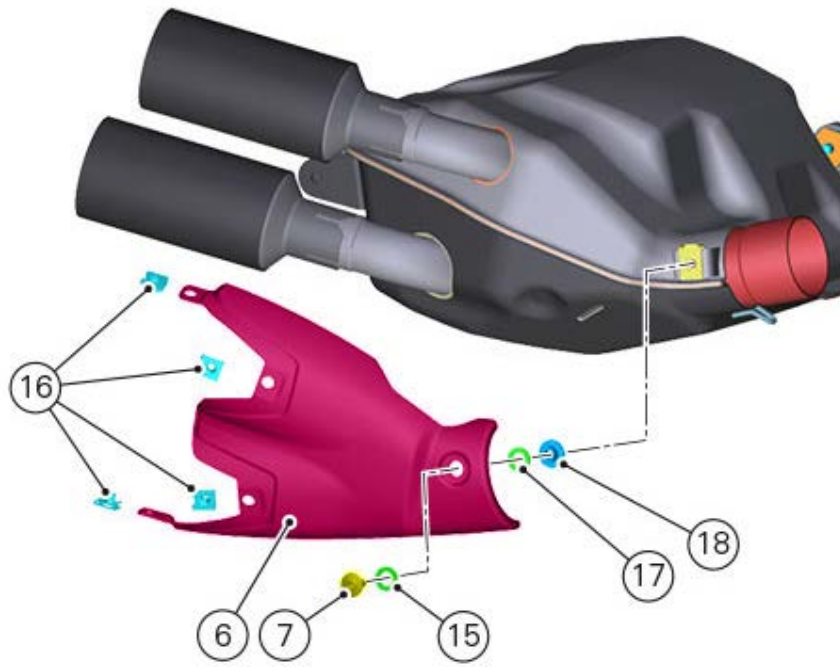

Fix the two exhaust pipes (4) with screws (5).

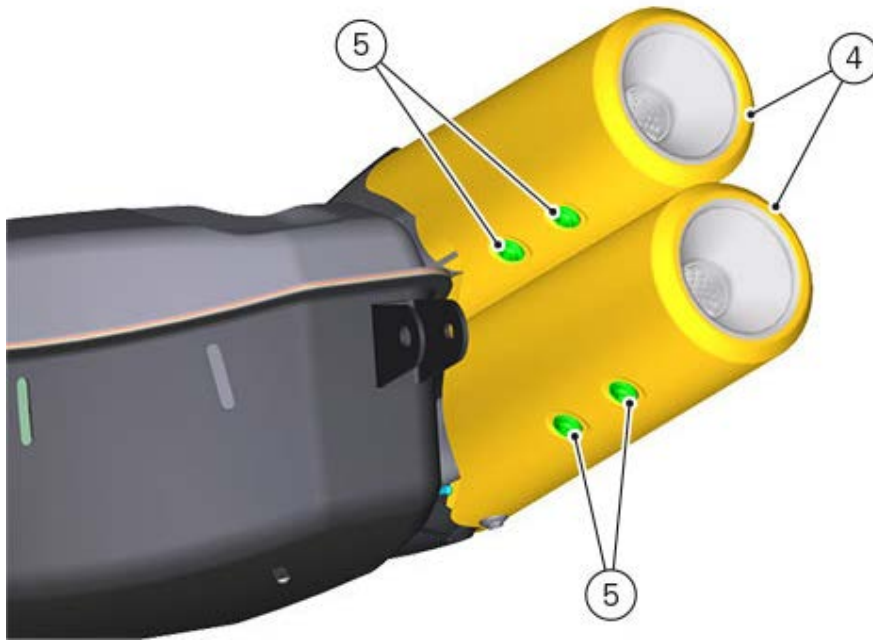
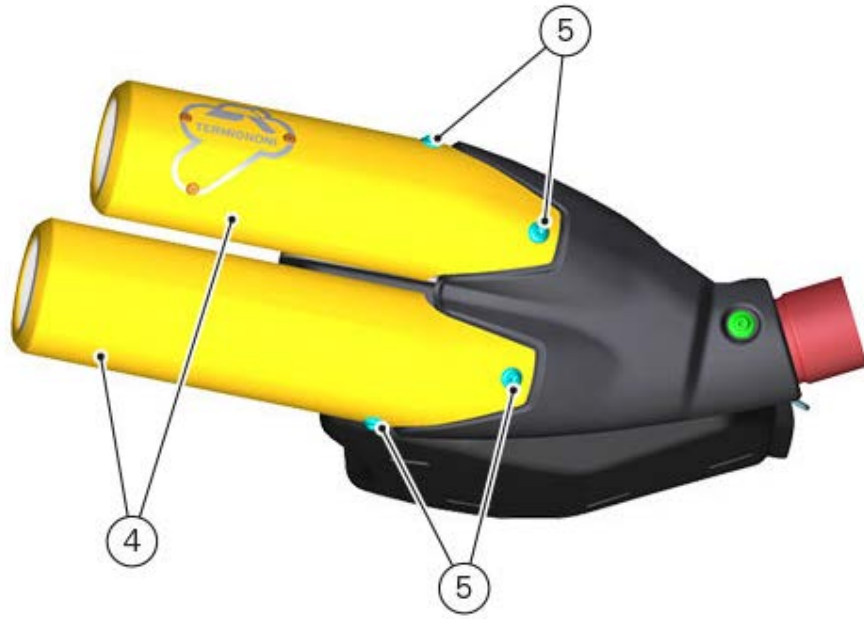

Removing the silencer

Loosen the silencer retaining screw (1) to the frame on the vehicle left side.

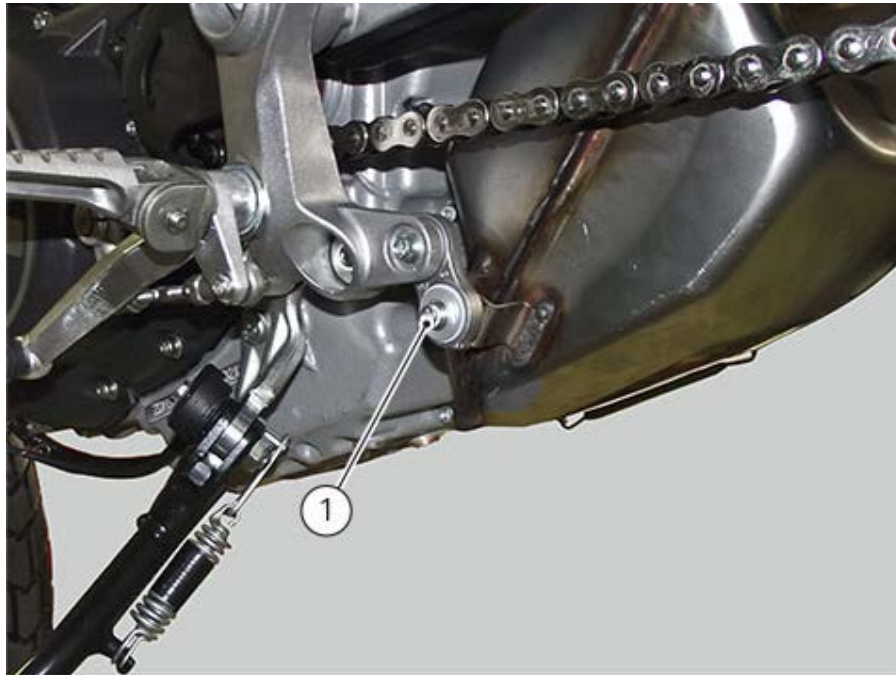

Working on the vehicle right side, loosen retaining screw (2).

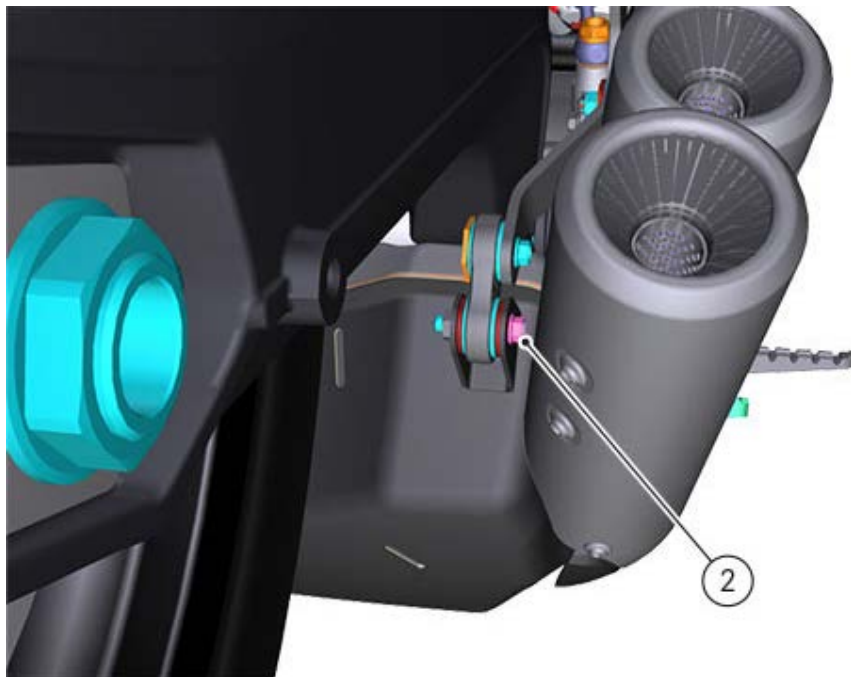

Remove spring (3).
Slide out the silencer.

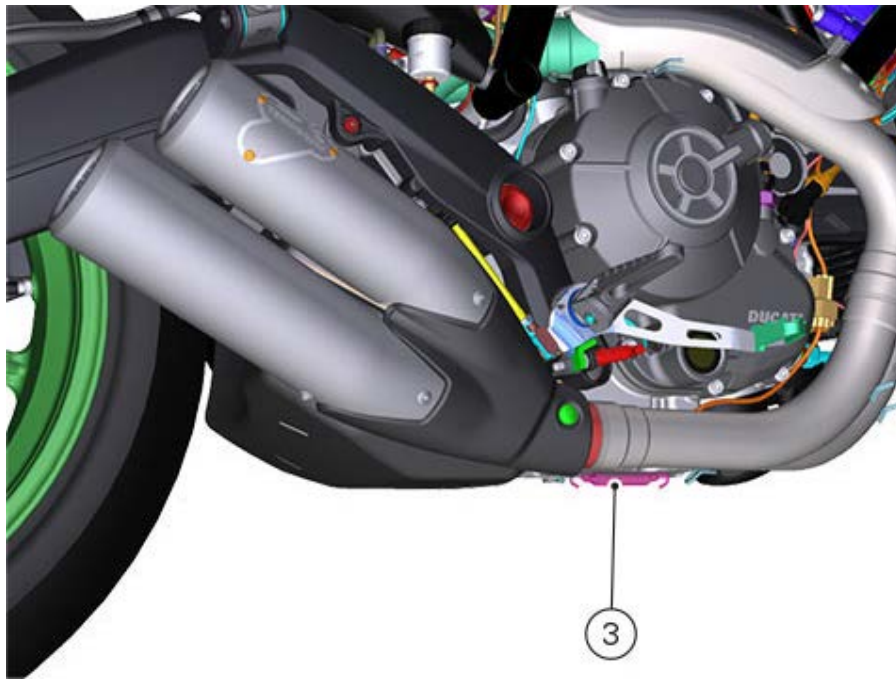

If it is necessary to disassemble the silencer, remove heat guard (4) by loosening the retaining screws (5). Remove heat guards (4).

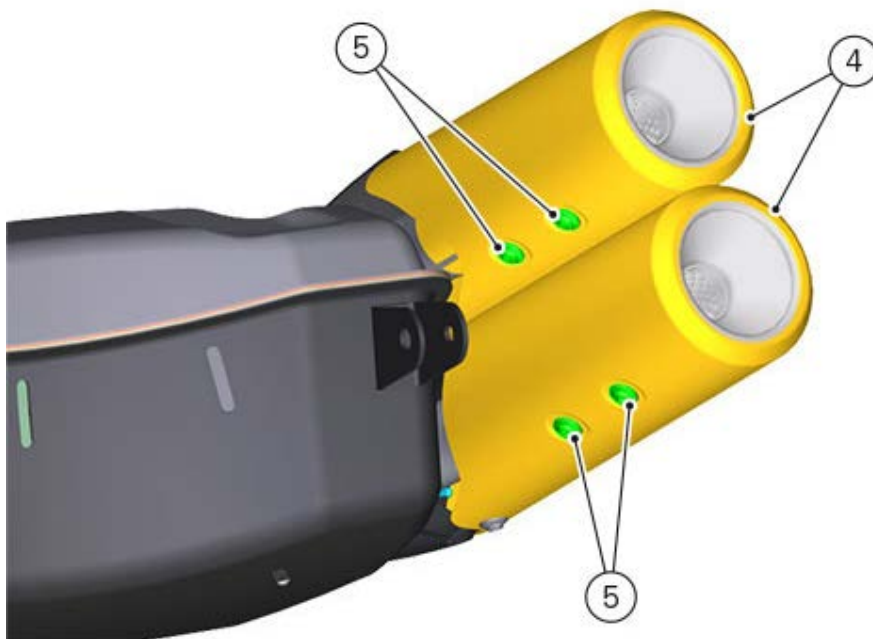

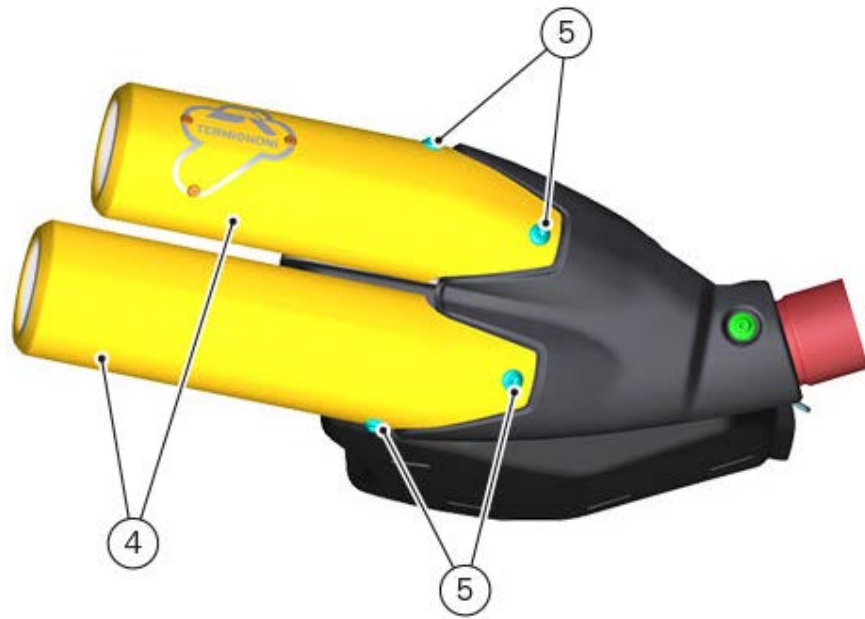

Remove heat guard (6) by loosening screw (7).

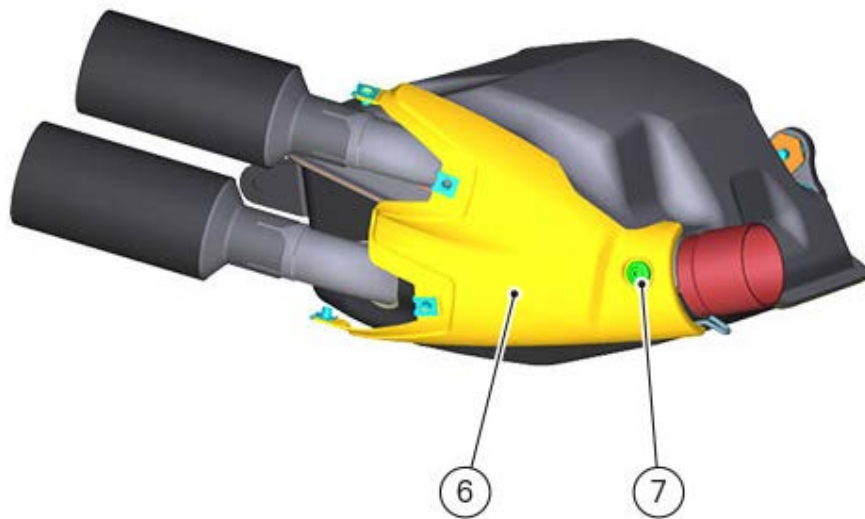

It is possible to separate the two exhaust pipes (8) from the central body (9) by loosening the two clamps (19).

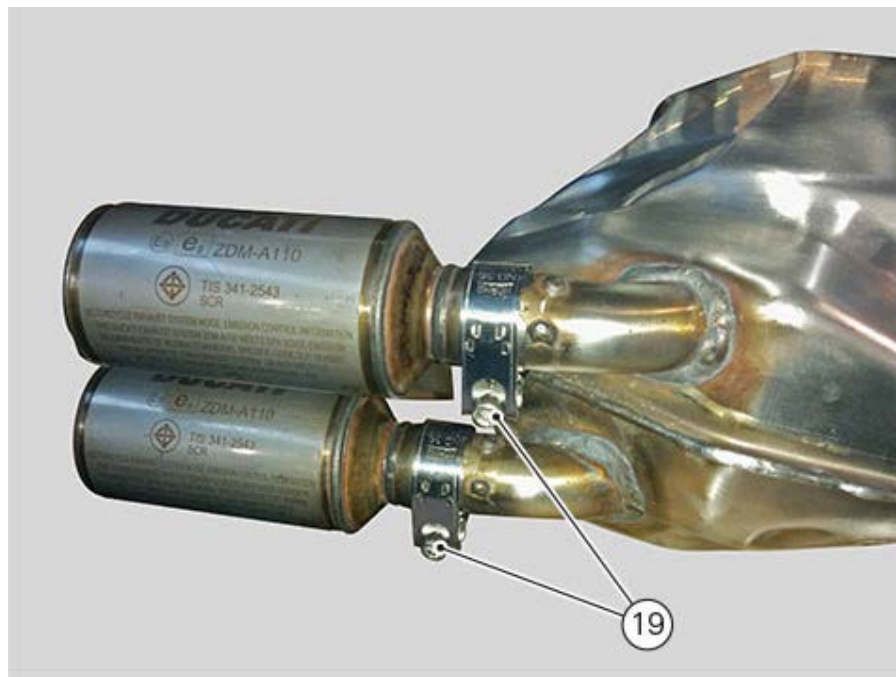
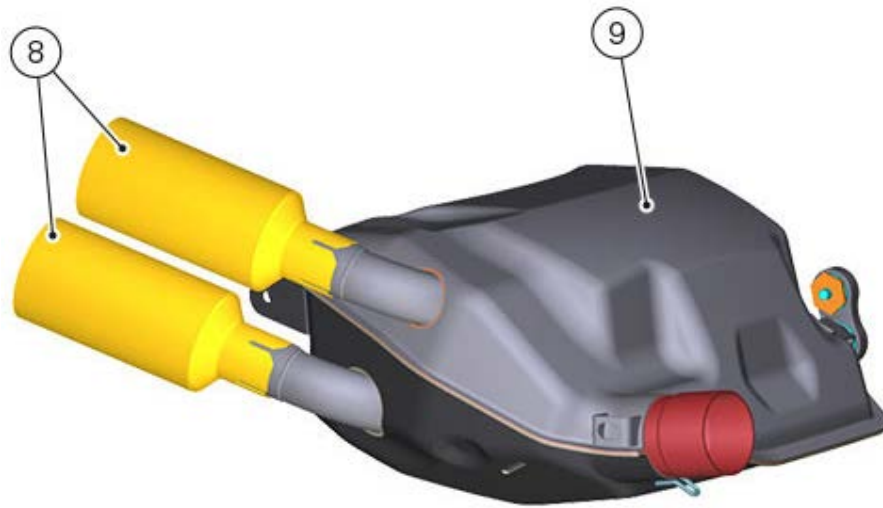

Refitting the exhaust system

Check the presence of the two clips (13) on the exhaust manifold.
Tighten plug (14) with relevant seal to a torque of $25 \text{ Nm} \pm 10\%$.
Start the lambda sensor and tighten it to a torque of $45 \text{ Nm} \pm 10\%$.



Fit the heat reflective material (15) in heat guard (16).

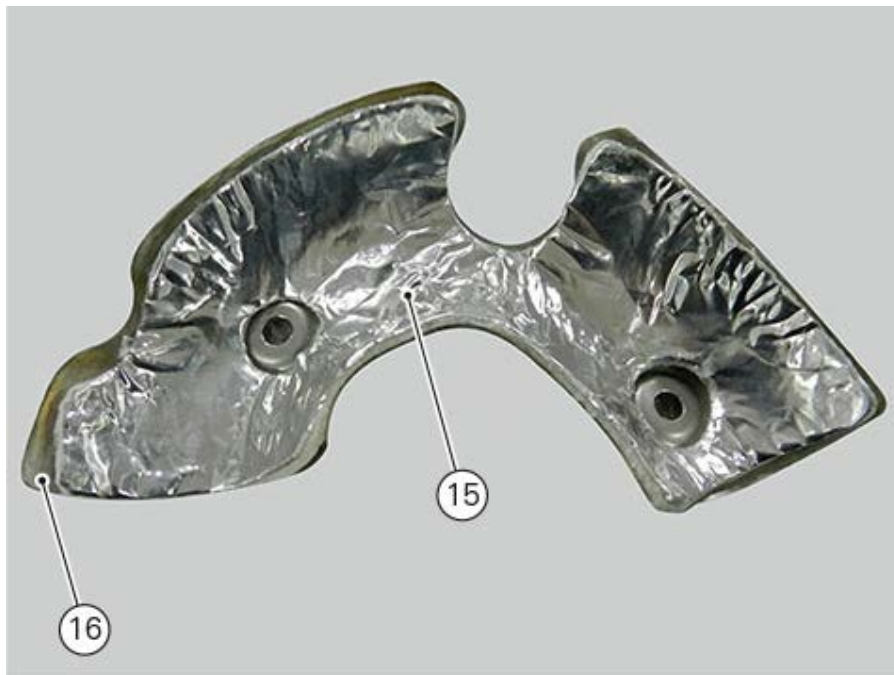

Position the two washers (17) on heat guard (16), apply indicated threadlocker and insert the two retaining screws (18) and tighten them to a torque of $8 \text{ Nm} \pm 10\%$.



Fix manifold (2) to the vertical head by starting screws (12) and tightening them starting from one of the two following the procedure below:

- The first one to $6 \text{ Nm} \pm 10\%$;
- The second one to $24 \pm 10\% \text{ Nm}$;
- Then again the first one to $24 \pm 10\% \text{ Nm}$.

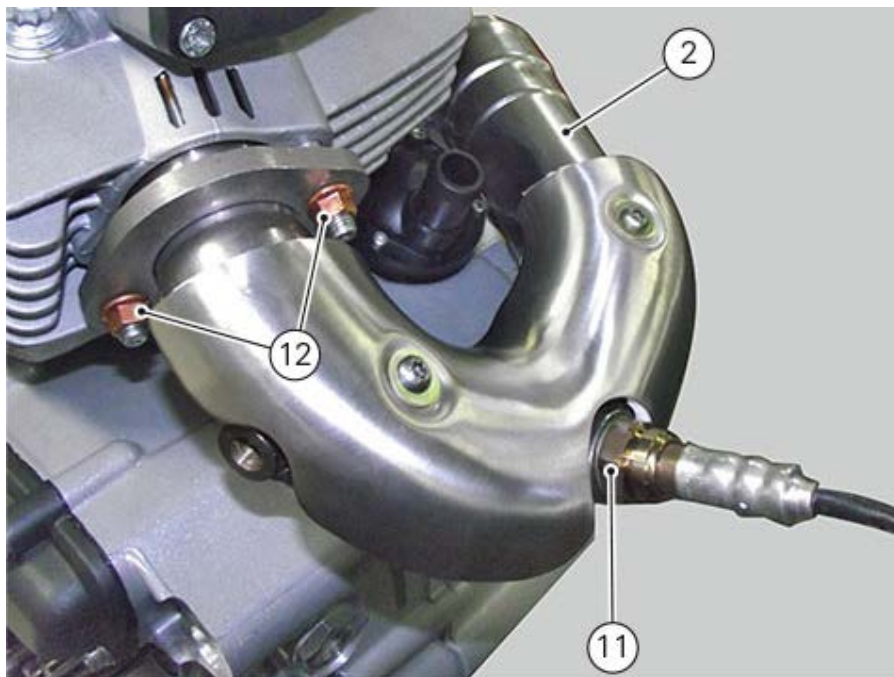

Insert the primary exhaust pipe (3) in manifold (2) and block it with spring (8).

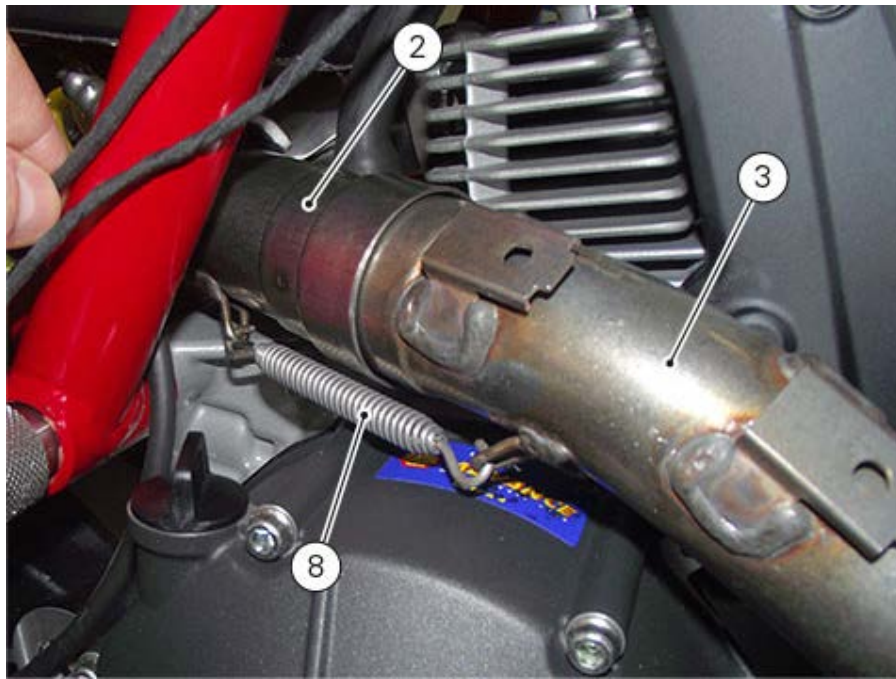

Fix manifold (1) to the horizontal head by starting screws (10) and tightening them starting from one of the two following the procedure below:

- The first one to $6 \text{ Nm} \pm 10\%$;
- The second one to $24 \pm 10\% \text{ Nm}$;
- Then again the first one to $24 \pm 10\% \text{ Nm}$.

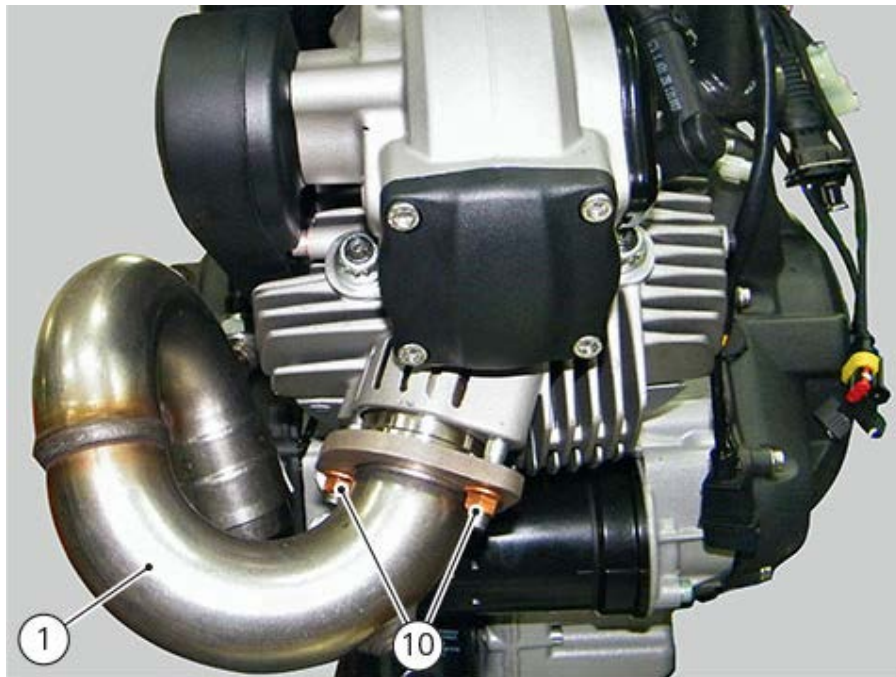

Fit the two clips (19) on the primary exhaust pipe (3) as shown in the figure.

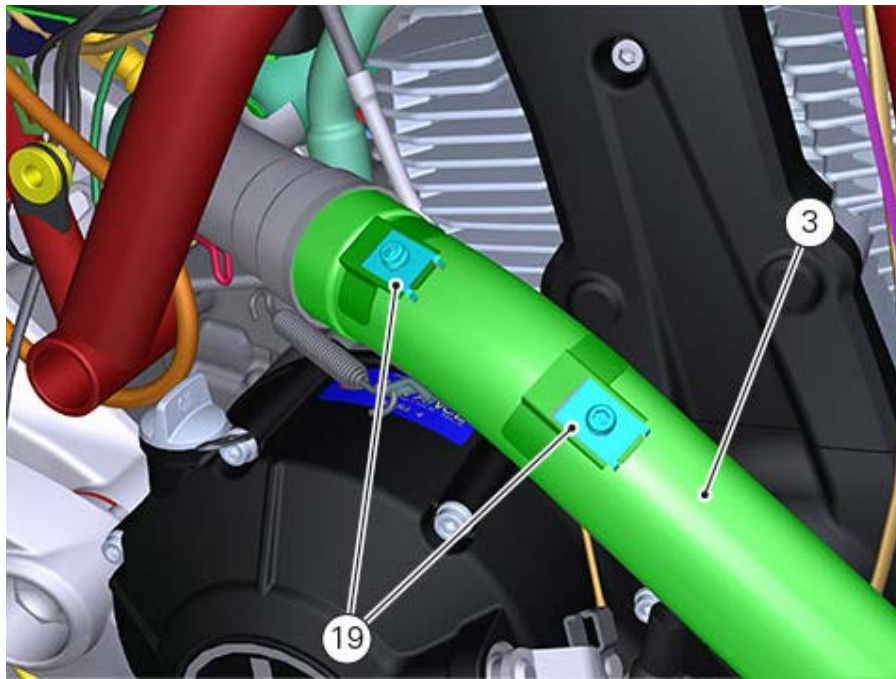

Position head guard (20) and tighten the two screws (21) to the torque of $5 \text{ Nm} \pm 10\%$.

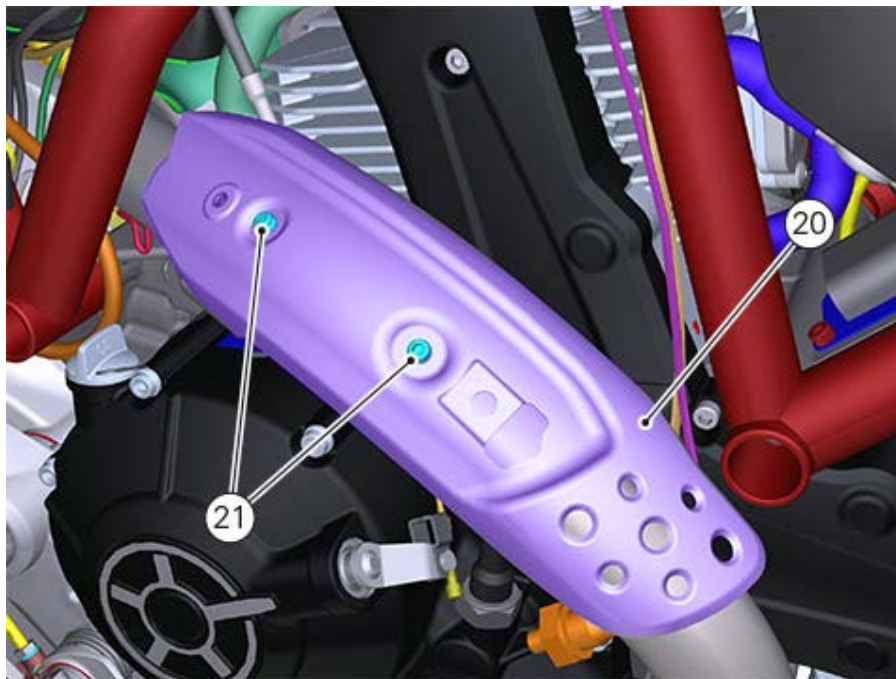

Fit cover (22) on heat guard (20), tightening two screws (23) to a torque of $5 \text{ Nm} \pm 10\%$.

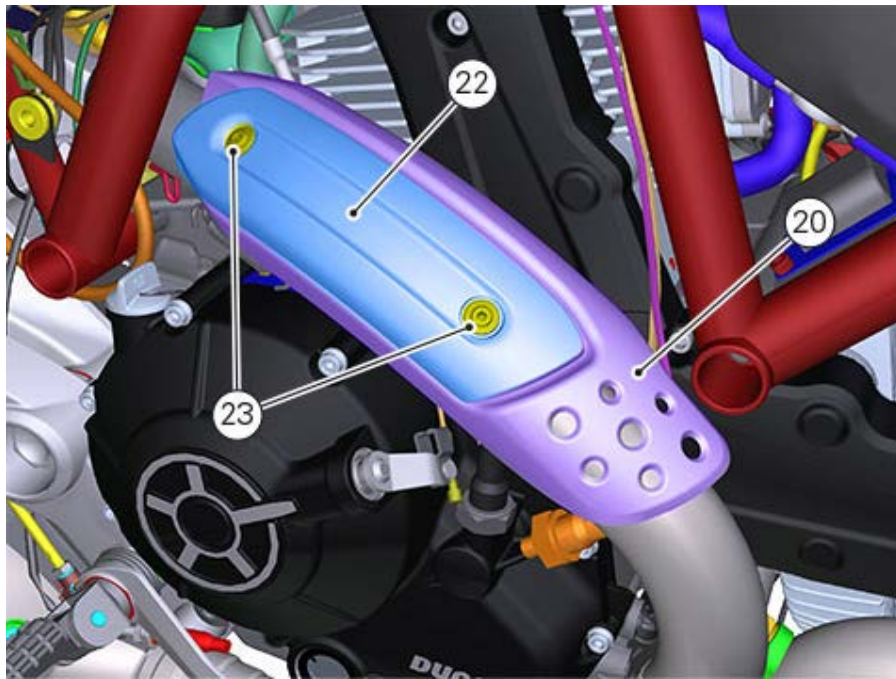

Fix the exhaust manifold (1) and the exhaust pipe (3) to the central body (4) through the two springs (6) and (7).

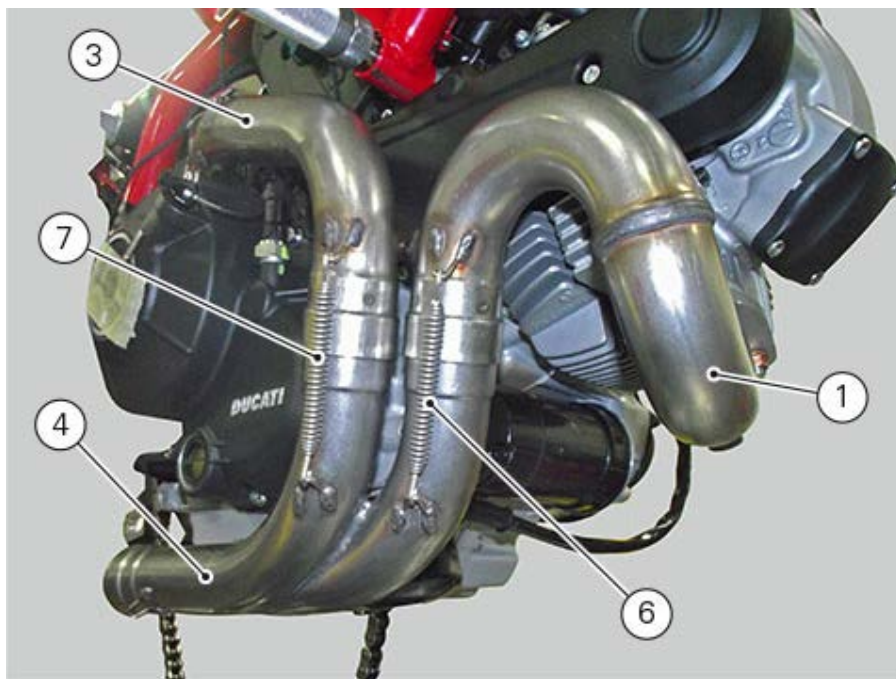

Refit the silencer ([Refitting the silencer](#)).

Removing the exhaust system

The exhaust system consists of the following parts:

- 1 Horizontal head exhaust manifold
- 2 Vertical head exhaust manifold
- 3 Vertical head primary exhaust pipe
- 4 Central body
- 5 Silencer

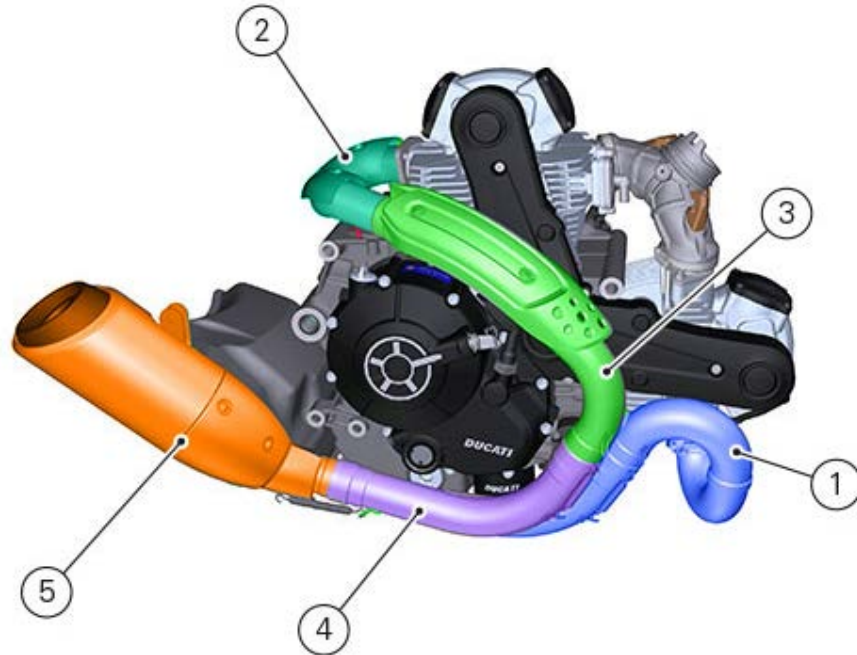

Remove the silencer ([Removing the silencer](#)).

Remove the spring (6) retaining the horizontal head exhaust manifold (1) to central body (4) and (7), primary exhaust pipe of vertical head (3) to central body (4).
Separate the central body.

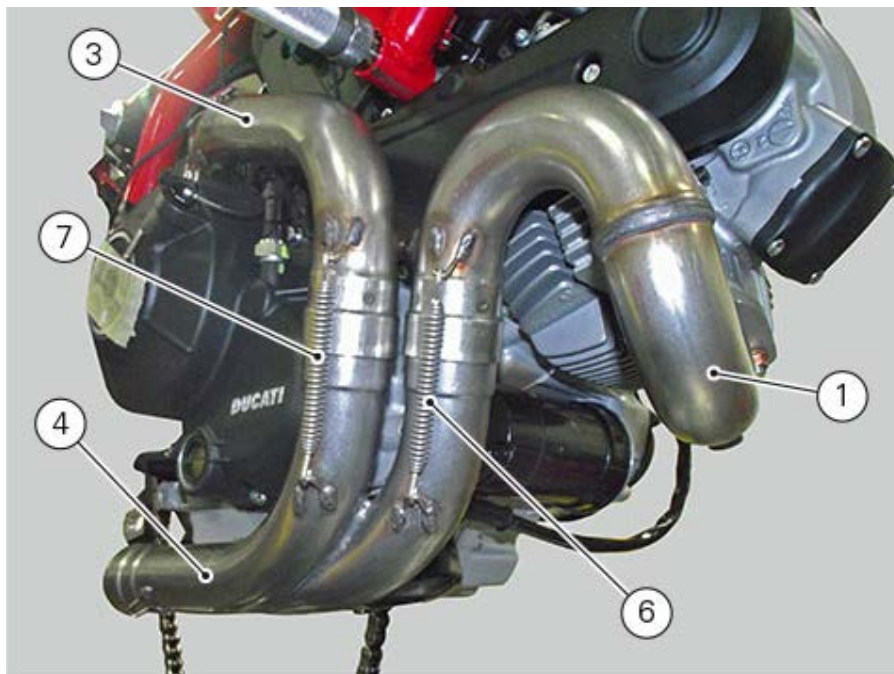

Remove the spring (8) retaining the vertical head exhaust manifold (2) to vertical head primary exhaust pipe (3).
Separate the vertical head primary exhaust pipe.

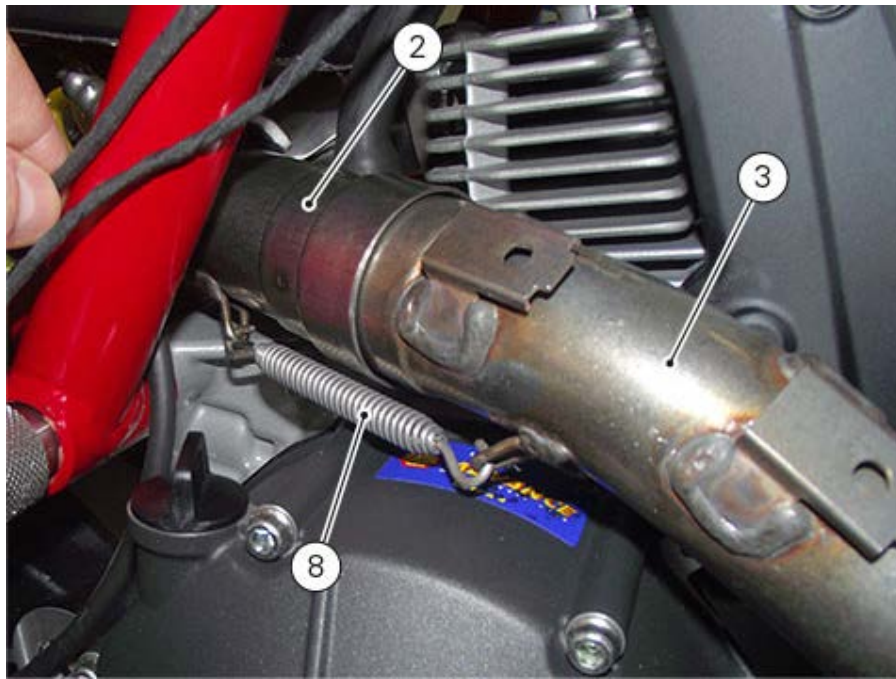

Loosen lambda sensor (9) of the horizontal cylinder head exhaust manifold (1).



Remove the exhaust manifold (1) from the horizontal head by loosening the two retaining screws (10).

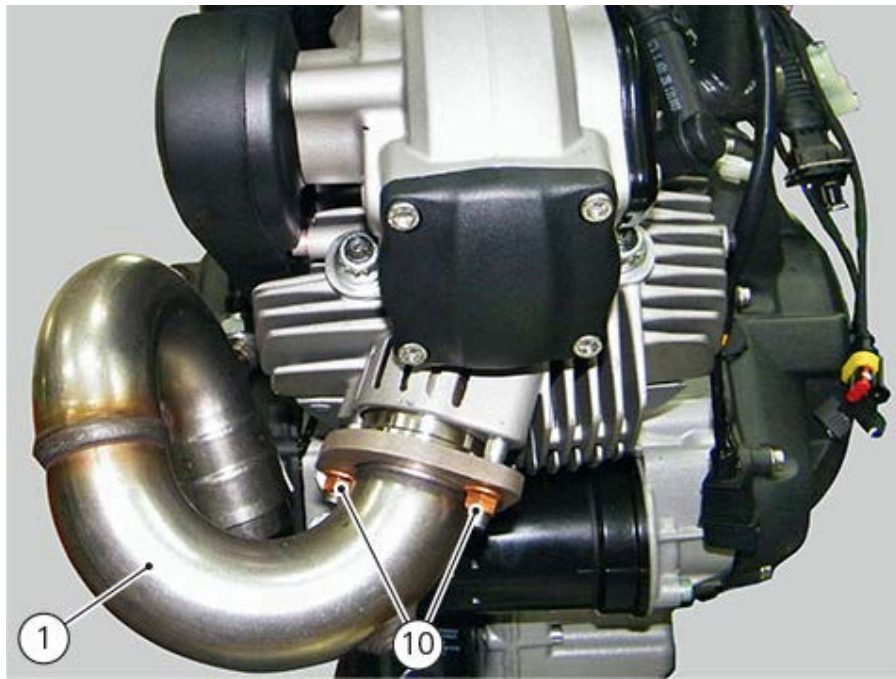

Loosen the lambda sensor (11) and remove the exhaust manifold (2) by loosening the two screws (12).

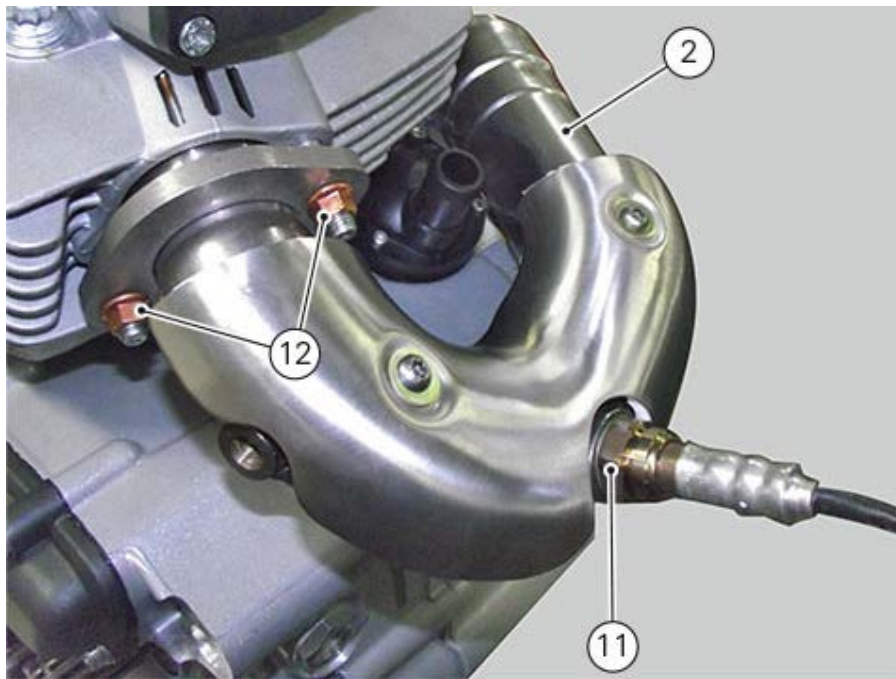

Refitting the silencer

Fix the silencer to the central part of the exhaust through spring (3).
Start and tighten screw (2) in the footpeg holder plate to a torque of $10 \text{ Nm} \pm 10\%$.

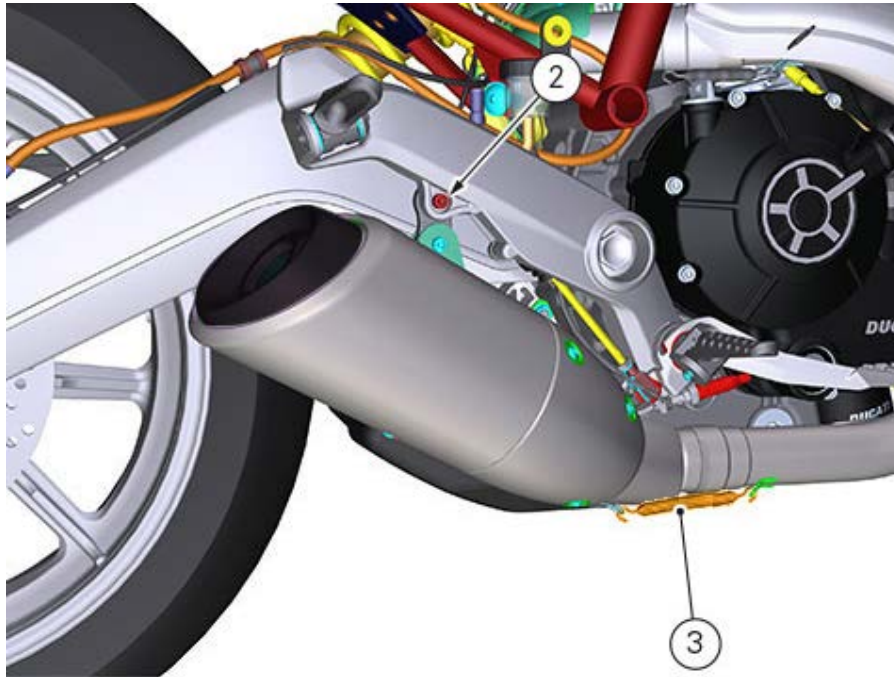

Working on vehicle left side, tighten screw (1) to a torque of $10 \text{ Nm} \pm 10\%$.

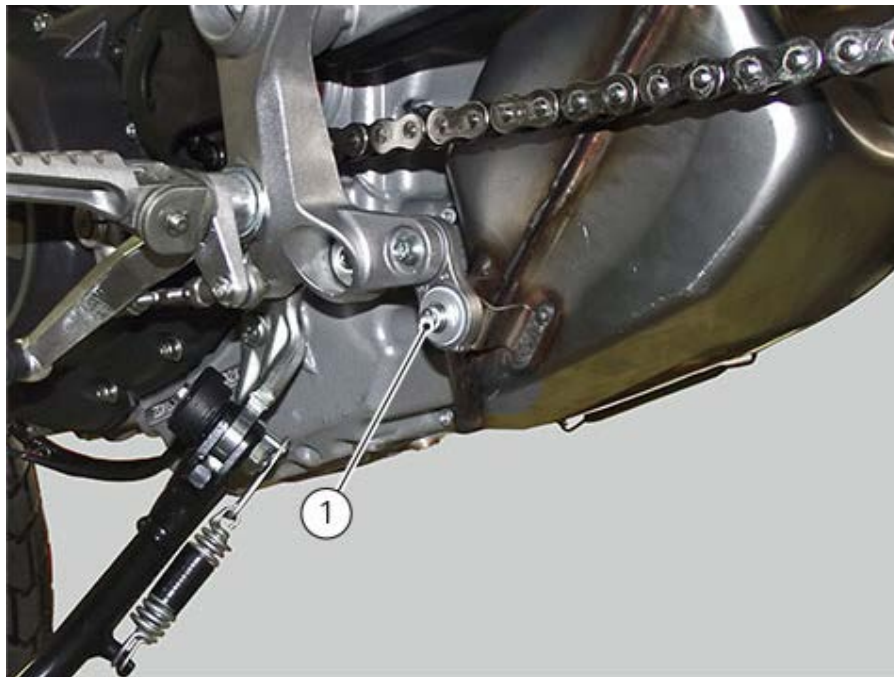

Fit the silencer external part (6) on the silencer.
Tighten screw (7) to a torque of $5 \text{ Nm} \pm 10\%$.

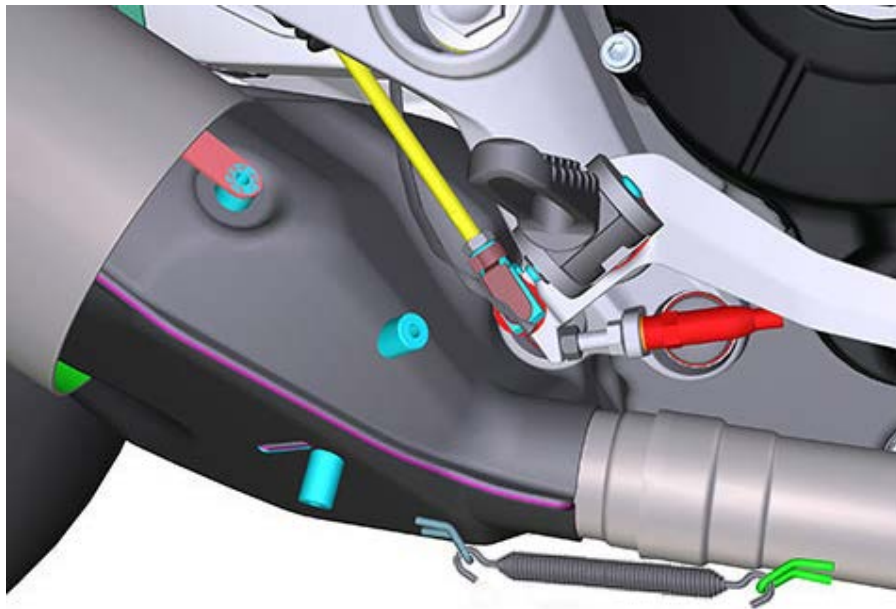
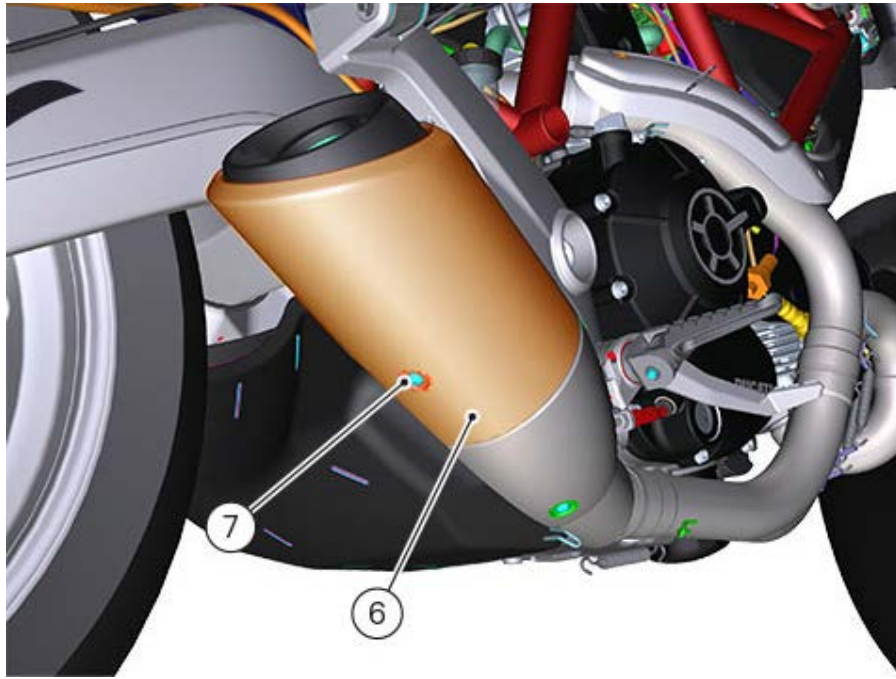

Fix heat guard (4) by tightening screws (5) to a torque of $5 \text{ Nm} \pm 10\%$.

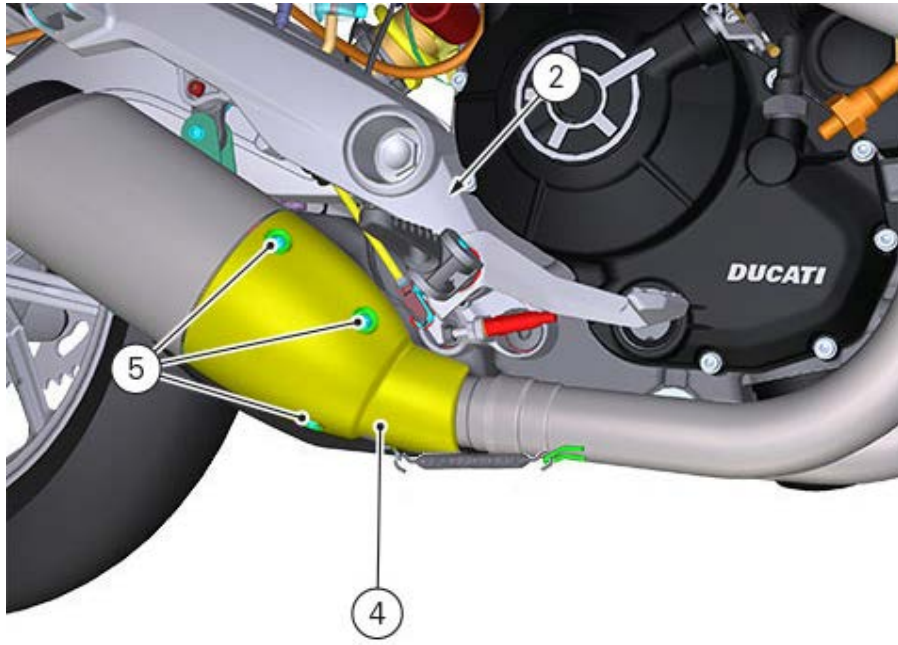

Removing the silencer

Loosen the silencer retaining screw (1) to the frame on the vehicle left side.

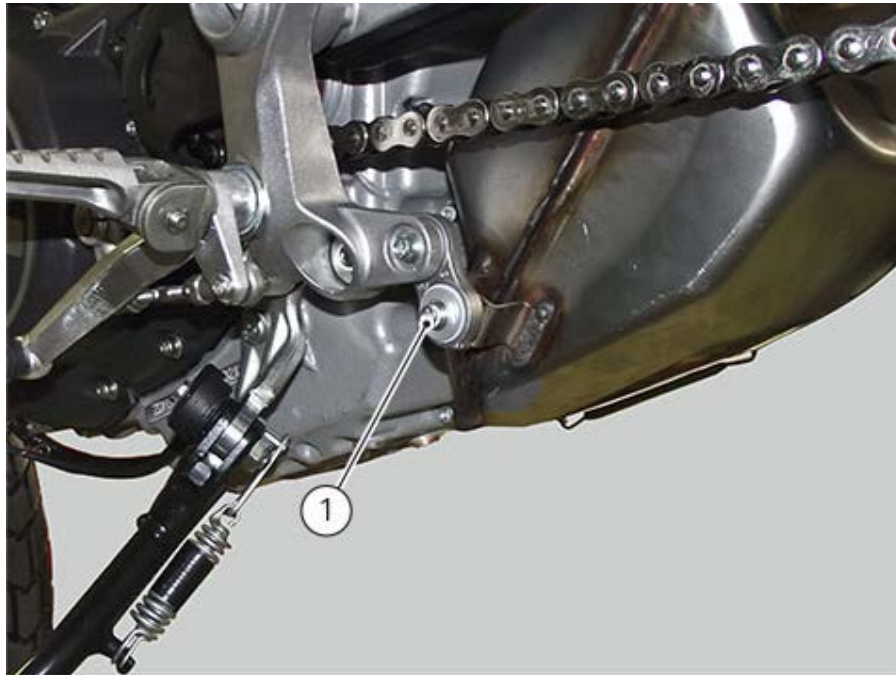

On the vehicle right side, loosen retaining screw (2) and remove spring (3). Slide out the silencer.

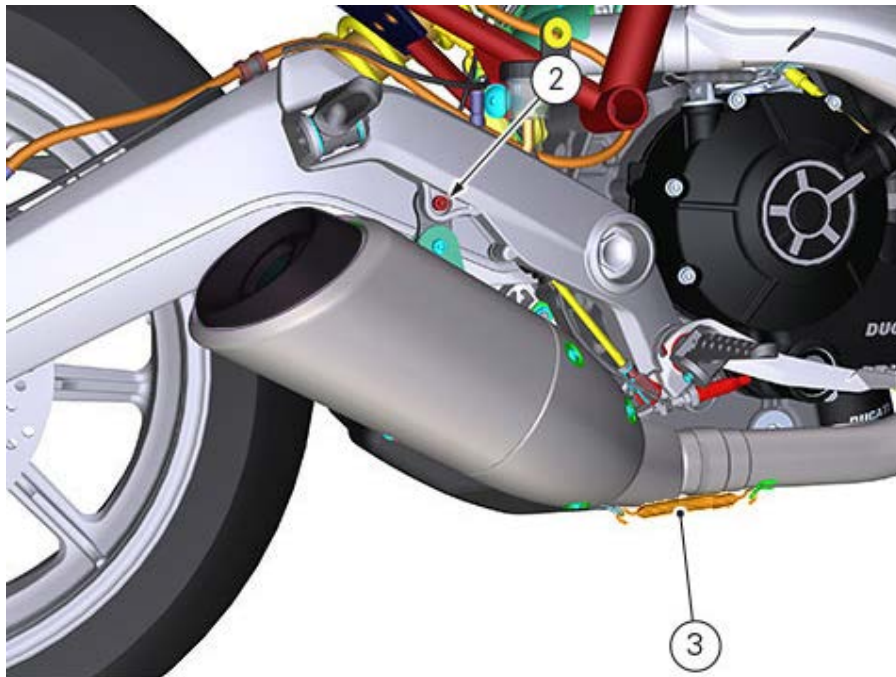

If it is necessary to disassemble the silencer, remove heat guard (4) by loosening the retaining screws (5).

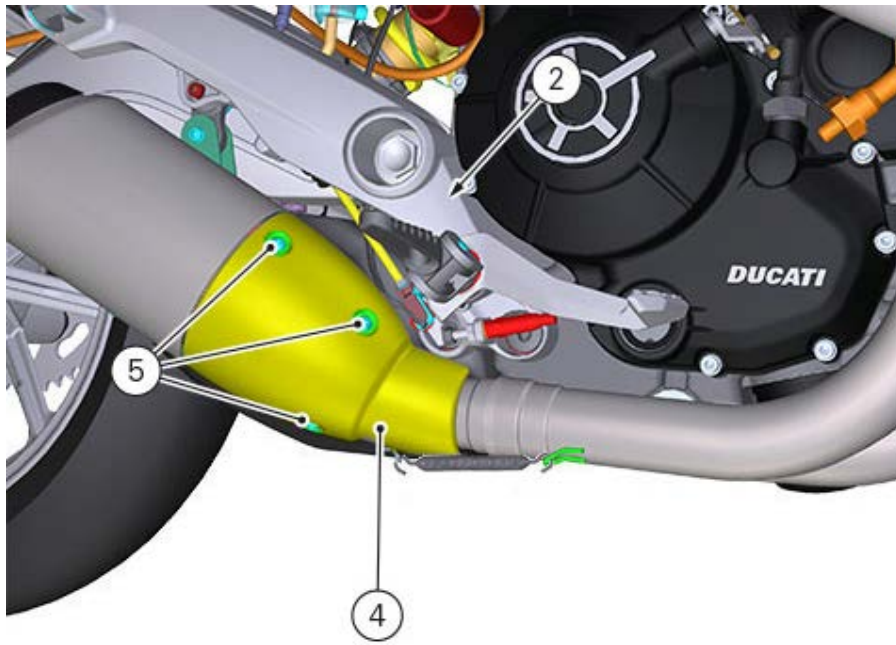

Remove the silencer external side (6) by loosening screw (7).

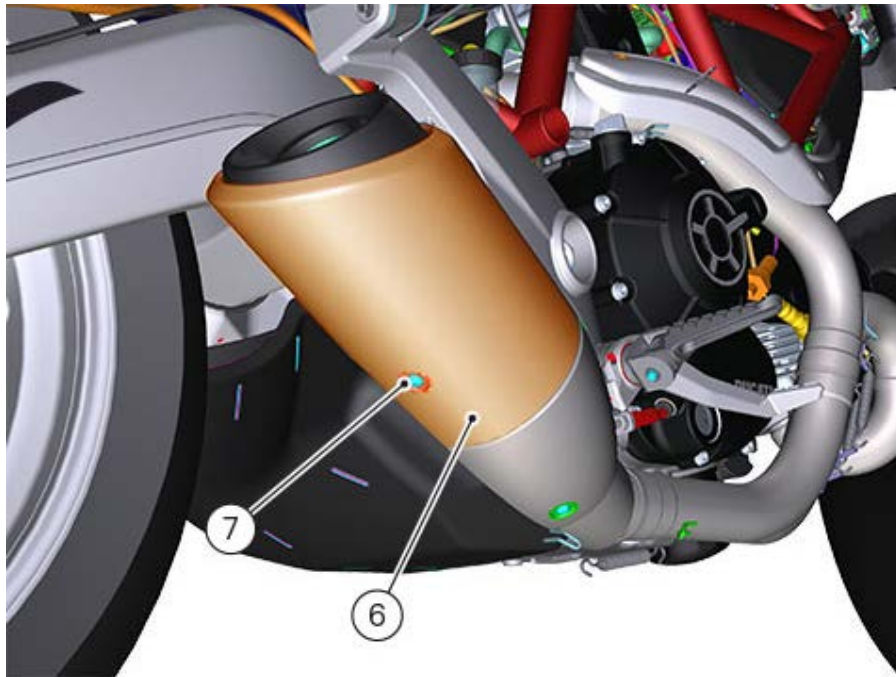



Refitting the Canister filter

Position the canister filter (8) and fix it to the bracket through nuts (7).
Tighten nuts (7) to a torque of $8 \text{ Nm} \pm 10\%$.

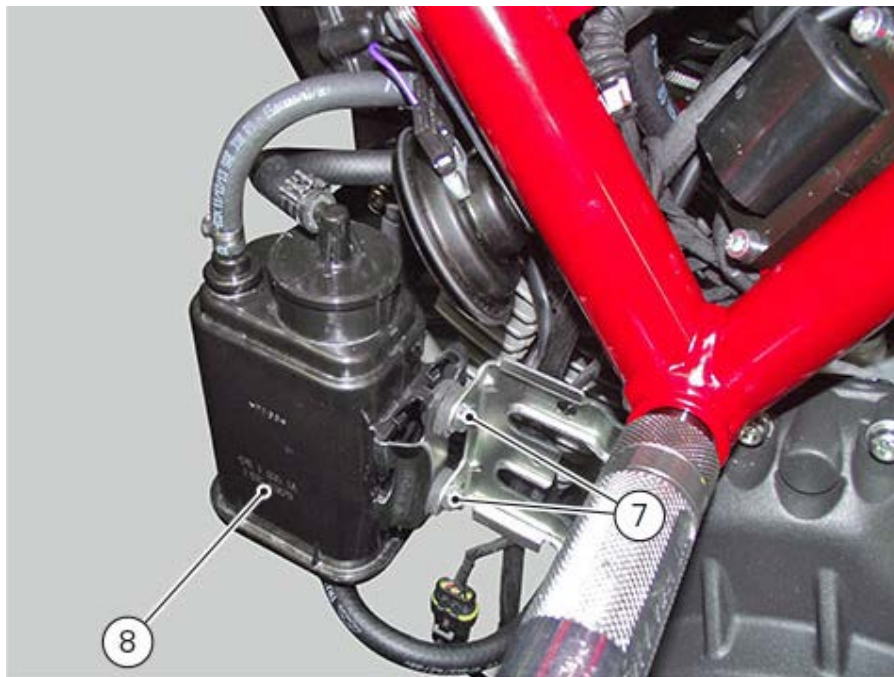

Position hoses (4), (5) and (6) on the filter and fix it with clips (1), (2) and (3).



Removing the canister filter

Remove clips (1), (2) and (3) and release hoses (4), (5) and (6) respectively.



Unscrew the two nuts (7) and remove the canister filter (8).

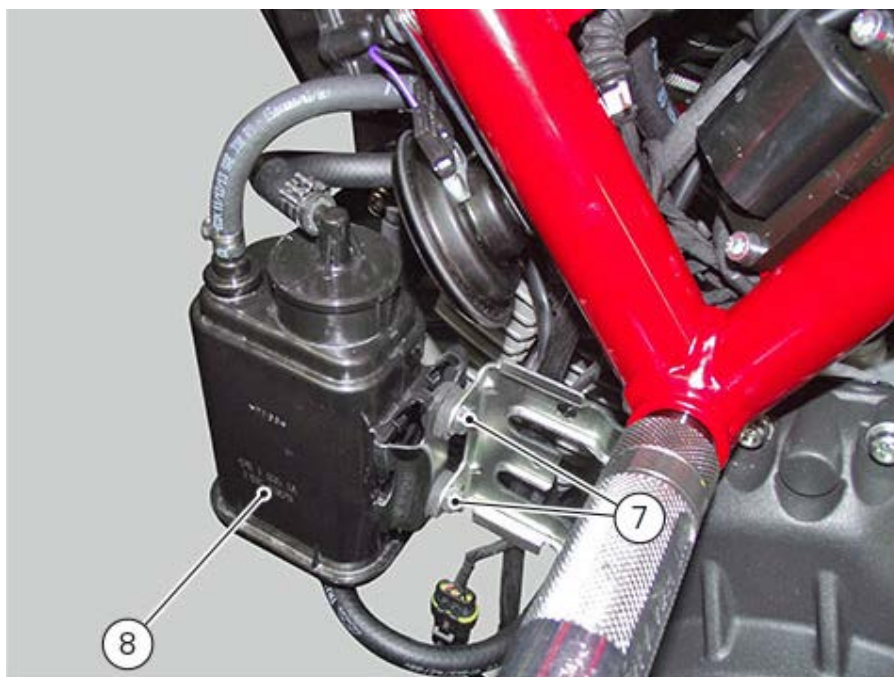

Canister filter system

USA models are equipped with an additional system featuring a Canister filter that prevents fuel fumes from being discharged into the atmosphere.

The breather hose (4) is connected to the Canister filter (1); when the fuel has been filtered, it is returned through the hose (2) to the intake manifold (A).
Pipe (3) vents to the ground.

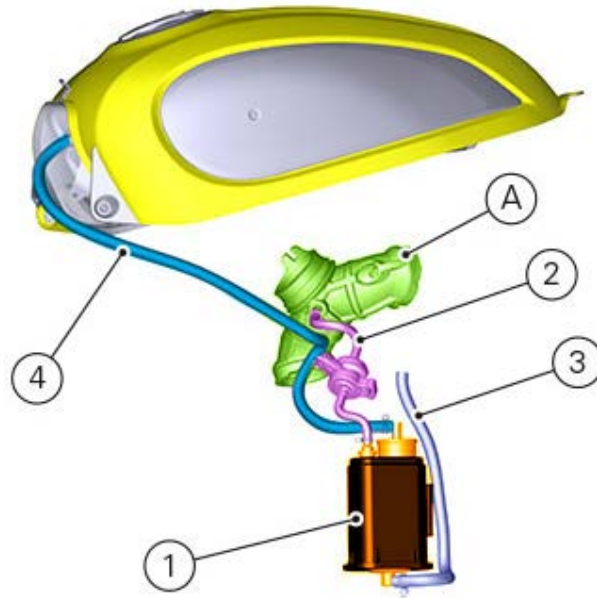

Refitting the engine

Fit the engine in the frame.



Lubricate screws (1) with the indicated grease and tighten to a torque of $60 \text{ Nm} \pm 5\%$.

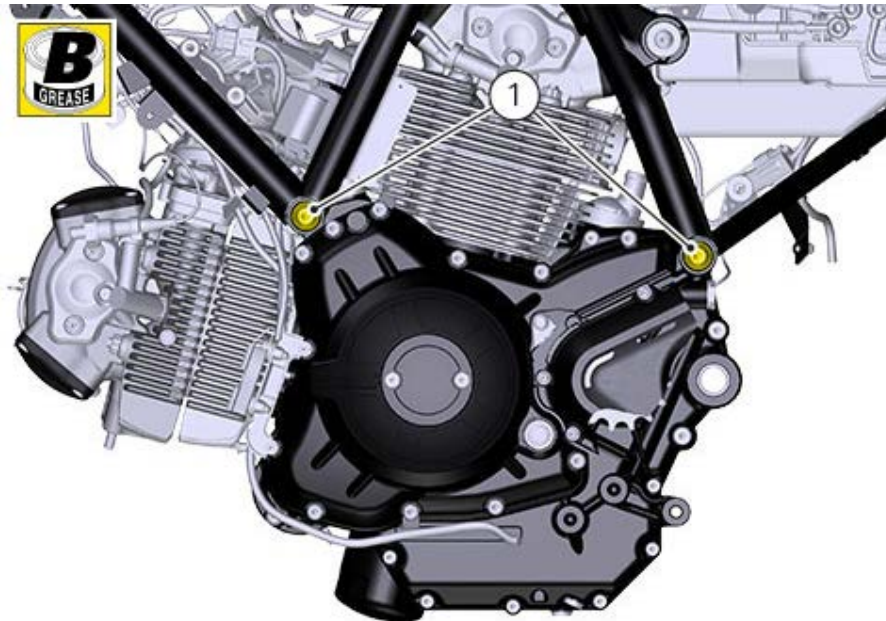

Refit the swinging arm ([Refitting the rear swinging arm](#)).

Refit the rear wheel ([Refitting the rear wheel](#)).



Refit the footpeg holder plates ([Refitting the footpeg support](#)).

Refit the side stand ([Refitting the side stand](#)).



Refit the clutch cable ([Refitting the clutch assembly](#)).

Refit the electric connections.

Refit the airbox ([Refitting the airbox](#)).

Refit the oil cooler ([Refitting the lubrication system](#)).

Refit the rear brake assembly ([Refitting the rear brake control](#)).

Refit the electric supports.

Refit the tank ([Refitting the fuel tank](#)).

Refit the fairings.

Refit the seat ([Refitting the seat](#)).



Removing the engine



- Remove the seat ([Removing the seat](#)).
- Remove the fairings.
- Remove the fuel tank ([Removing the tank](#)).
- Remove the electric supports.
- Remove the side stand ([Removing the side stand](#)).
- Remove the rear brake system ([Removing the complete rear brake control](#)).
- Remove the oil cooler ([Removing the lubrication system](#)).
- Remove the airbox ([Removing the airbox](#)).
- Remove the exhaust system ([Removing the exhaust system](#)).
- Remove the electric connections
- Remove the clutch cable ([Removing the clutch assembly](#)).



- Use a vice to block the front wheel and an elastic band to retain the front brake lever.
- Remove the footpeg holder plates ([Removing the front footpeg support](#)).
- Remove the battery



Remove the swinging arm ([Removing the rear swinging arm](#)).
Position a support under the engine.



Remove the two pins (1) that retain the engine to the frame.
Remove the engine from the frame.

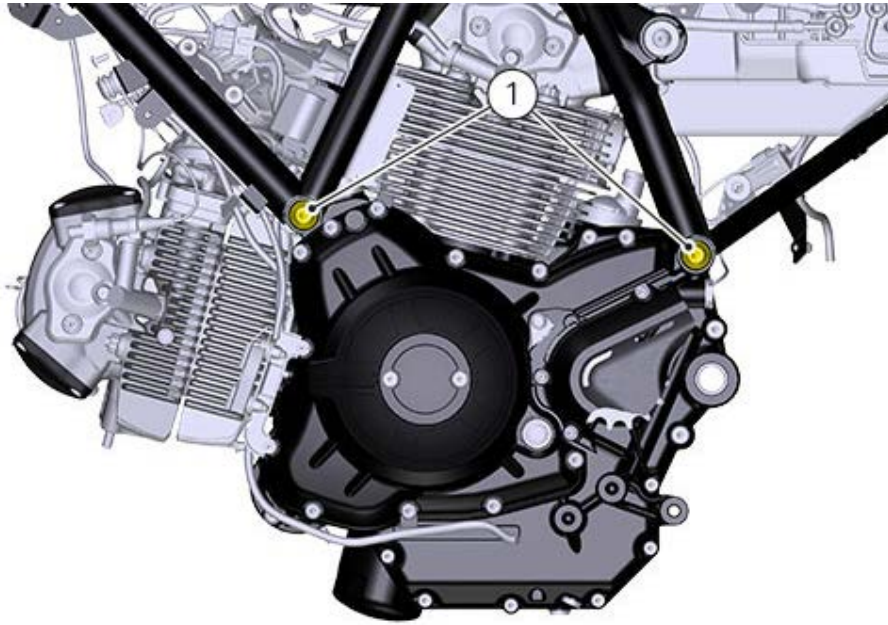

Refitting the oil pump

Position the reference bushes (5) and O-rings (4) according to the casing lubrication channels.

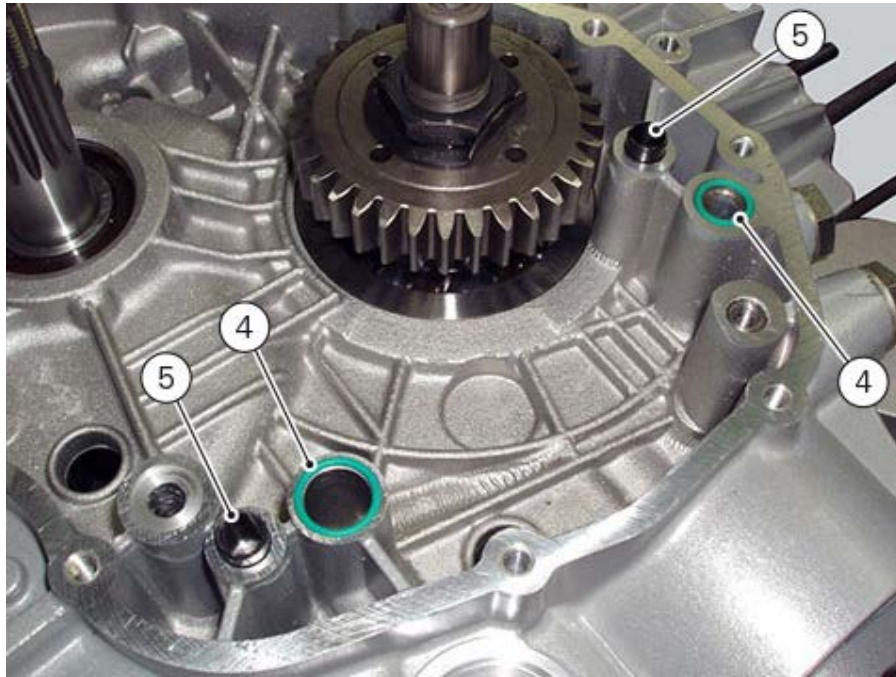

Place oil pump (3) on the casing.

Start screws (1) and (2) retaining the complete pump.

Tighten screws (1) to 26 Nm (Min 23 Nm - Max 29 Nm) and screw (2) to 10 Nm (Min 9 Nm - Max 11 Nm).

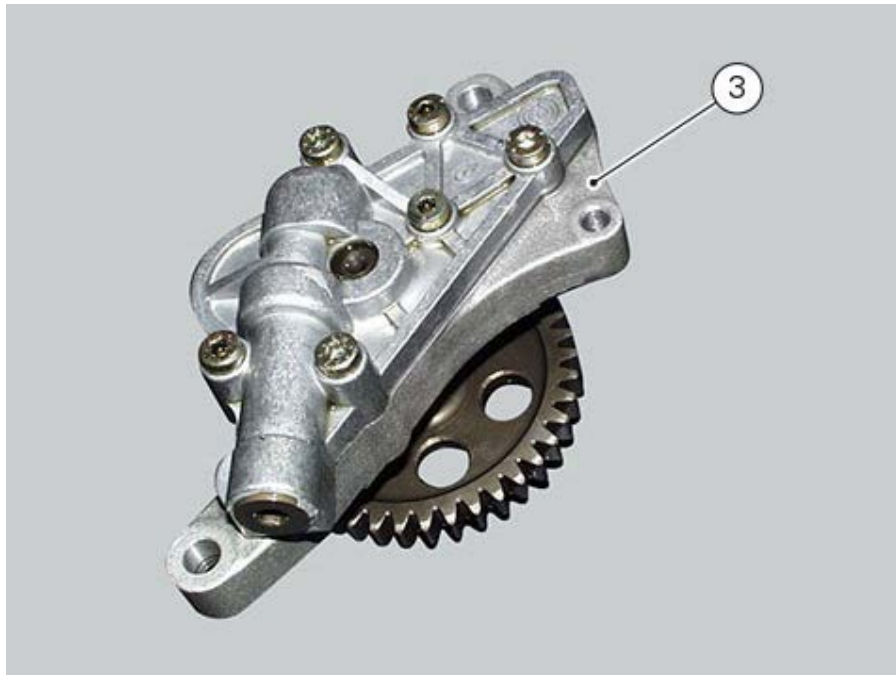

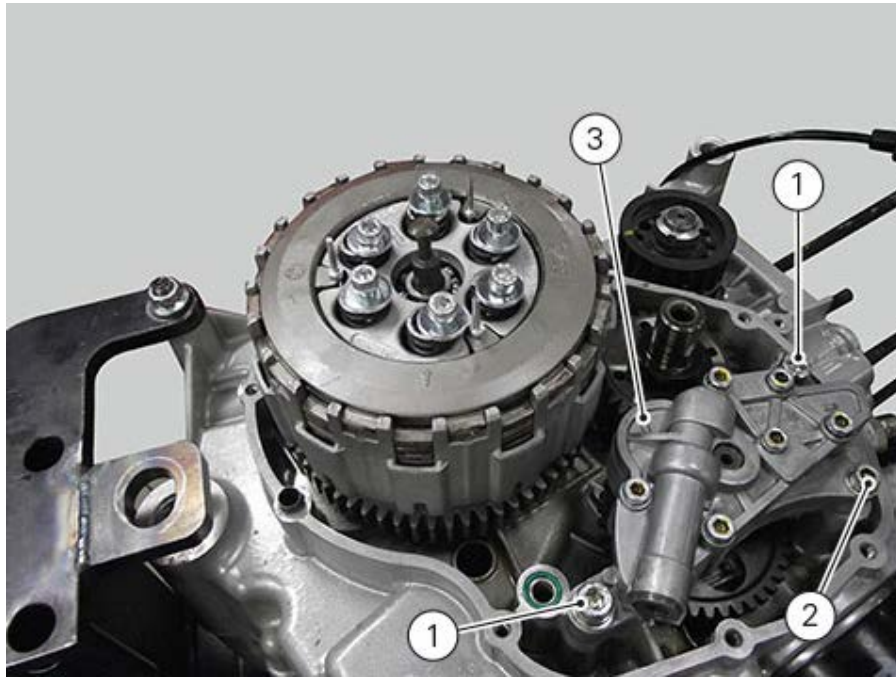

Check the backlash with the front sprocket.
Move the gear slightly to measure the backlash; take four readings in opposed positions.
The backlash must be 0.10 mm. To take the measurement use a dial gauge.

Refit the clutch cover ([Refitting the clutch cover](#))
Fill the lubrication system ([Changing the engine oil and filter cartridge](#))

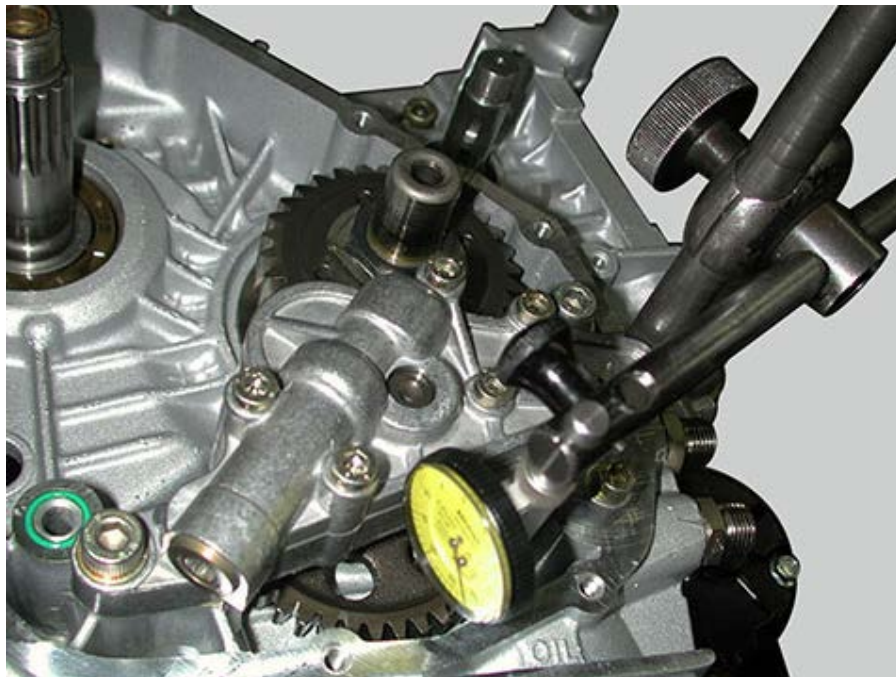

Reassembling the oil pump

Fit the oil pump control gear (10) on oil pump checking the presence of key (11).
Lock the gear using circlip (9).

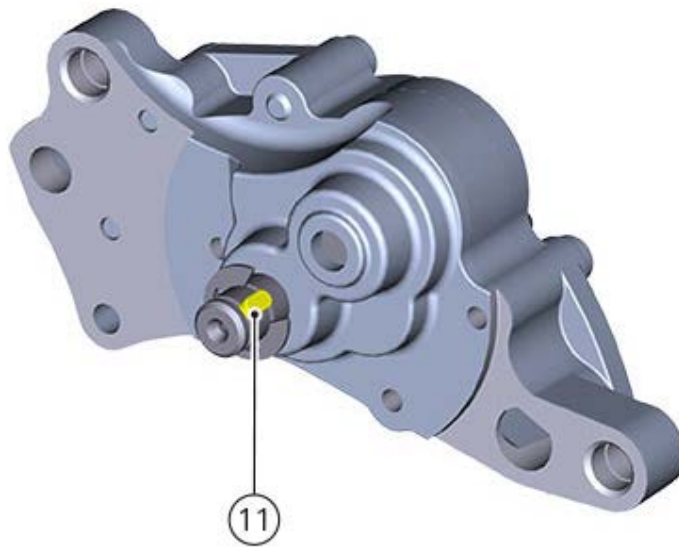

Insert by-pass valve (8), spring (7) and plug (6).
Tighten plug (6) to a torque of 17 Nm (Min 15 Nm - Max 19 Nm) after applying the indicated threadlocker.

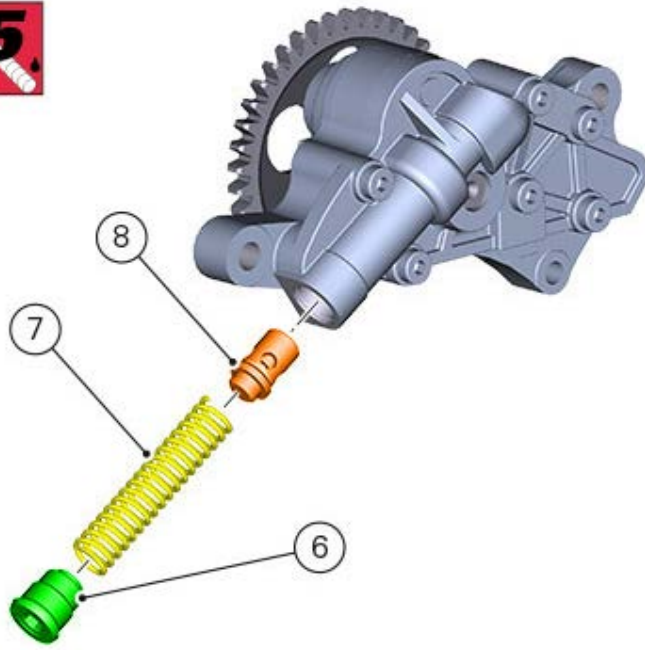

Disassembling the oil pump gear

Remove the plug (6) and extract the spring (7) and by-pass valve (8).
Check their wear conditions.

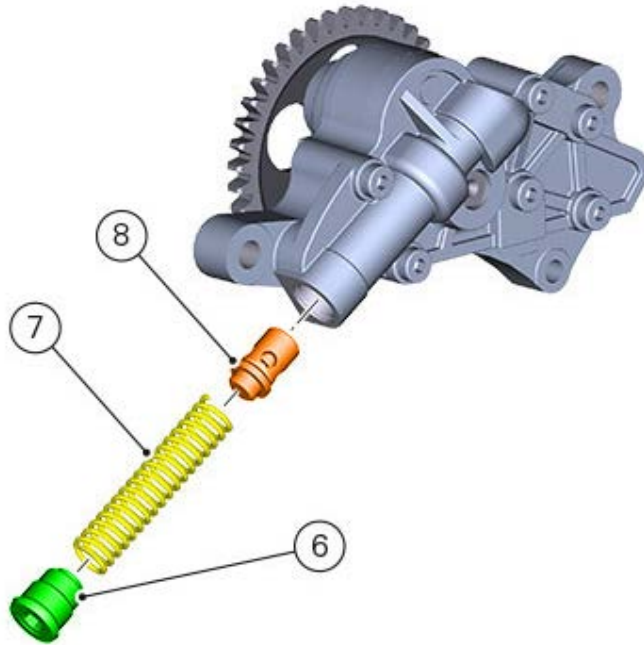

Remove circlip (9) and withdraw the pump drive gear (10).



Removing the oil pump

Empty the lubrication system ([Changing the engine oil and filter cartridge](#))

Remove the clutch cover ([Removing the clutch cover](#))

Loosen and remove screws (1) and (2) retaining the complete pump.
Remove the complete oil pump (3).

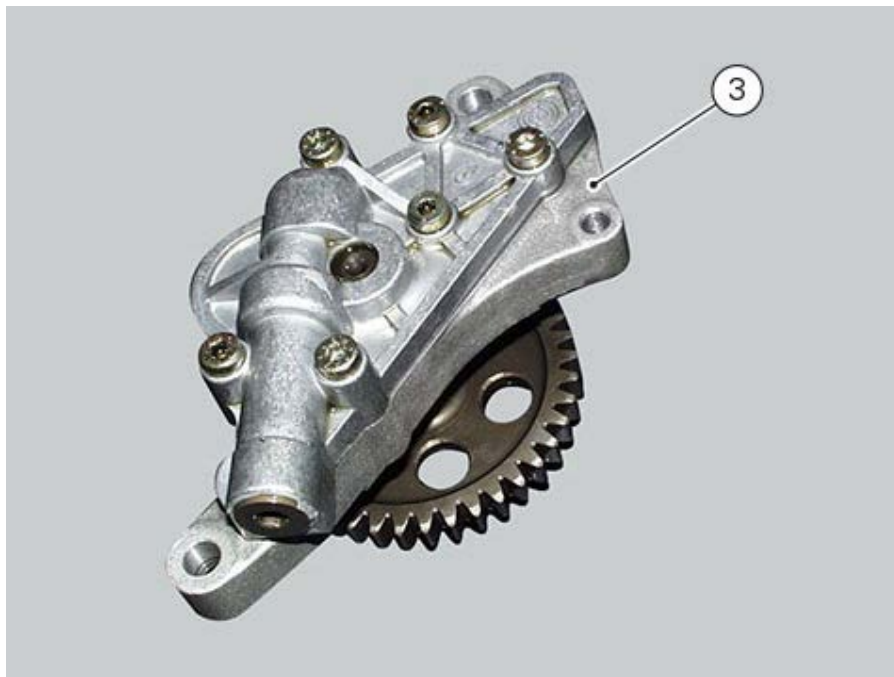
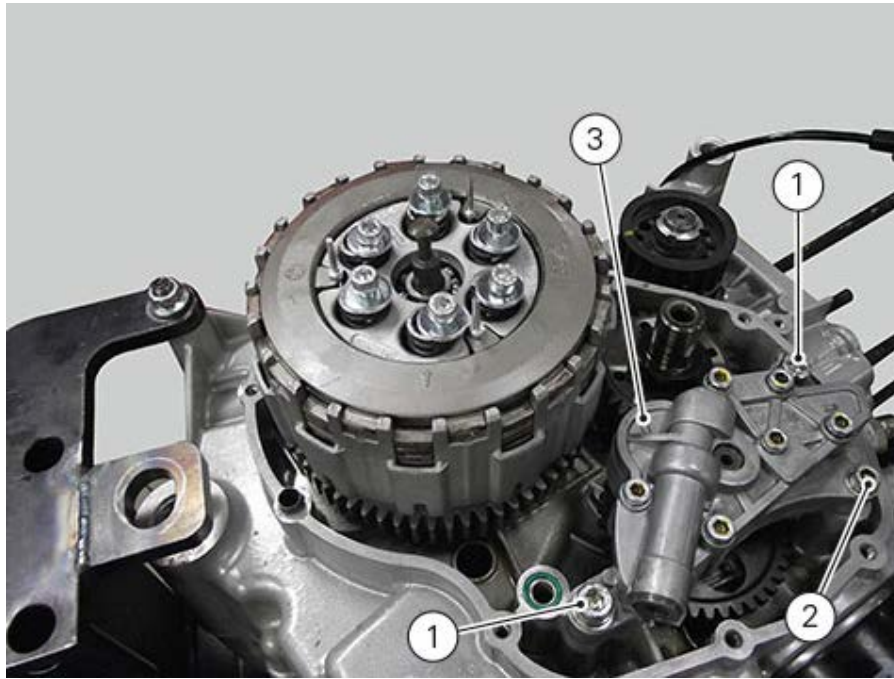

Extract the two O-rings (4) from the crankcase half together with two bushes (5).

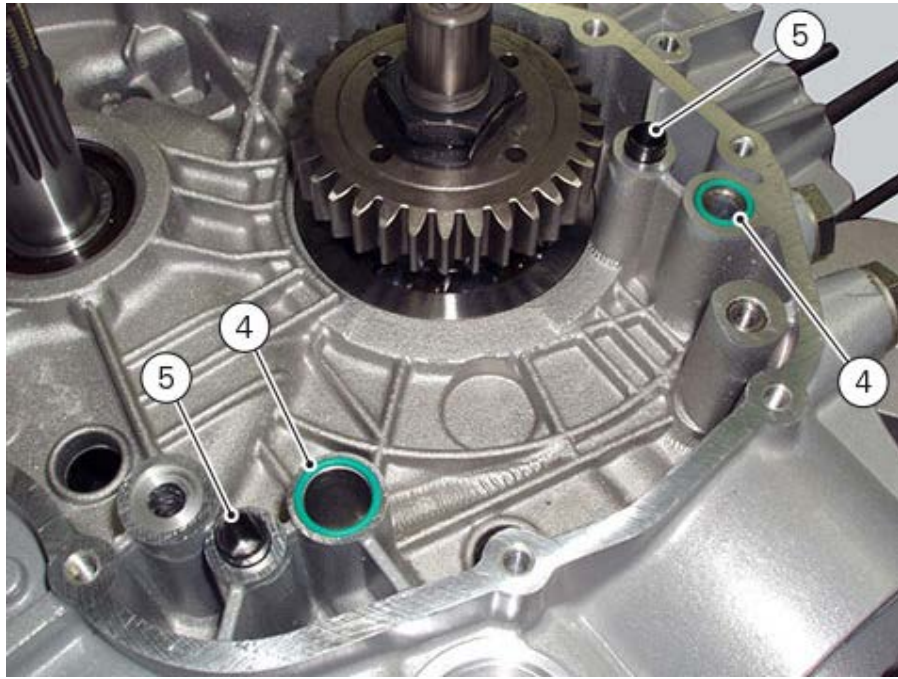

Refitting the lubrication system

Important

The gasket must be positioned with the sharp edge facing the cooler.

Start nipples (9) on oil cooler with gasket (10) and tighten them to $23 \text{ Nm} \pm 10\%$.
Tighten nuts (8) to a torque of $25 \text{ Nm} \pm 5\%$ to fasten pipes (6) and (7).

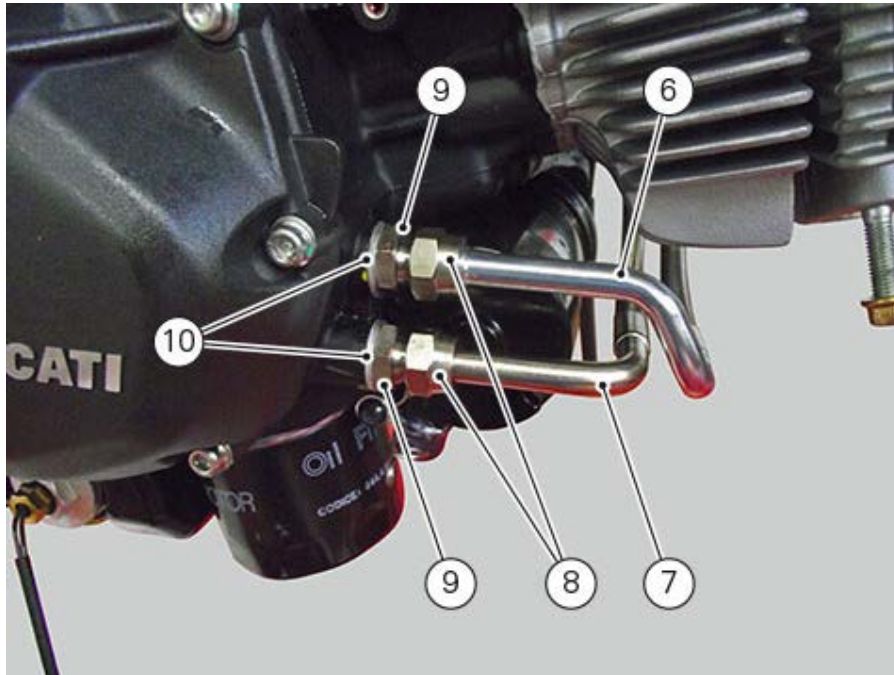

Position the oil cooler (5) and fix it by means of the two screws (4).
Tighten the two screws (4) to a torque of $10 \text{ Nm} \pm 10\%$.
Tighten the two nuts (1) and (2) to a torque of $\pm 18 \text{ Nm} 5\%$.
Tighten nut (3) on the oil pressure switch to a torque of $18 \text{ Nm} \pm 5\%$.

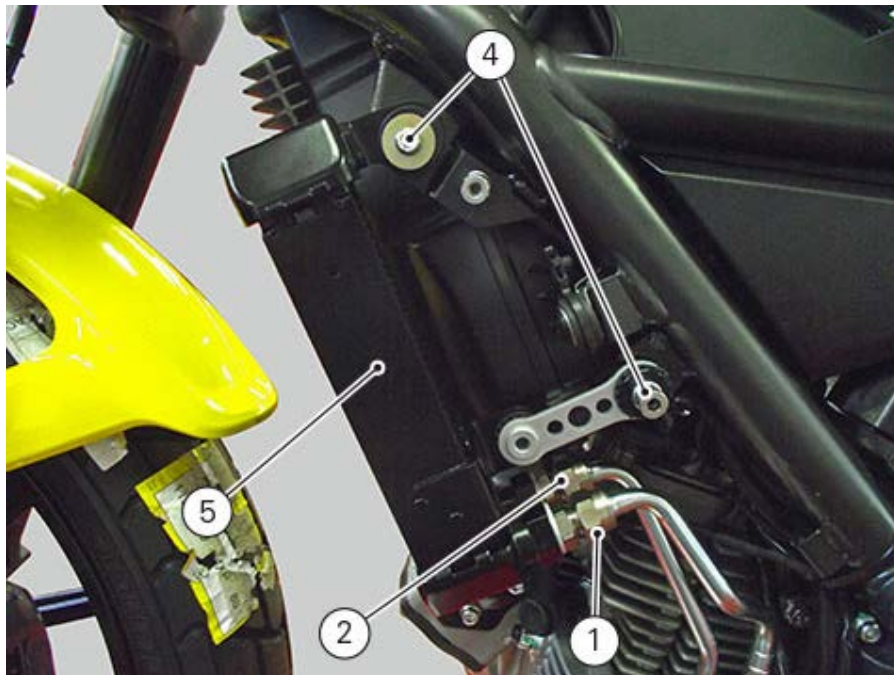



Inspecting the oil cooler

Visually inspect the cooler. Replace it at any sign of damage or leaks.

Removing the lubrication system

Remove the side fairings ([Removing the airbox](#)).

Remove the exhaust system ([Removing the exhaust system](#)).

Drain the engine oil ([Changing the engine oil and filter cartridge](#)).



Note

Pay attention that during the lubrication system removal procedure, oil can spill from the couplings.

Loosen and remove the two oil couplings (1) and (2).

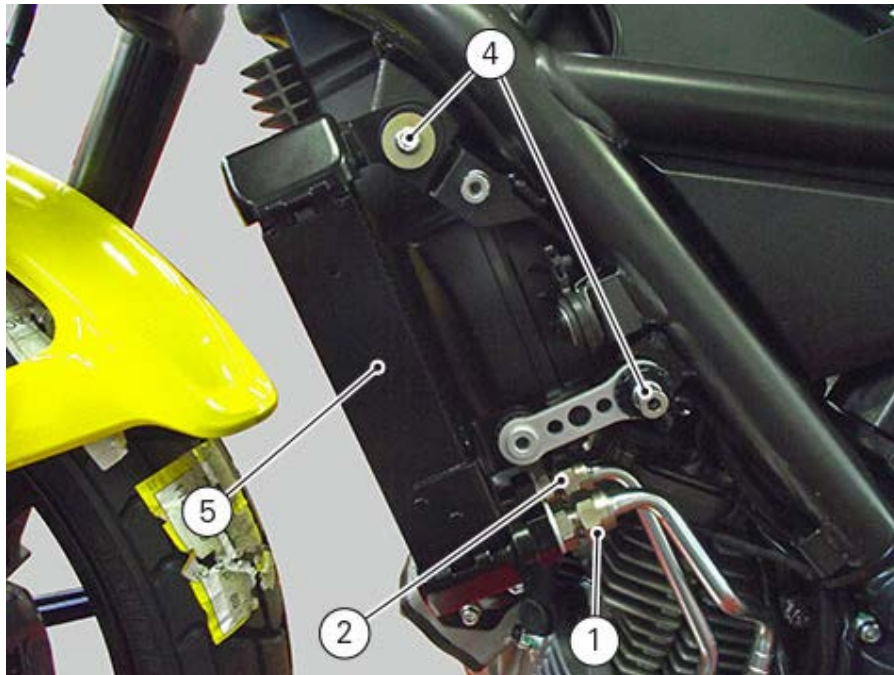

Loosen and remove the oil pressure switch coupling (3) recovering the gasket.



Undo the two retaining screws (4) of oil cooler (5).
Remove the oil cooler.

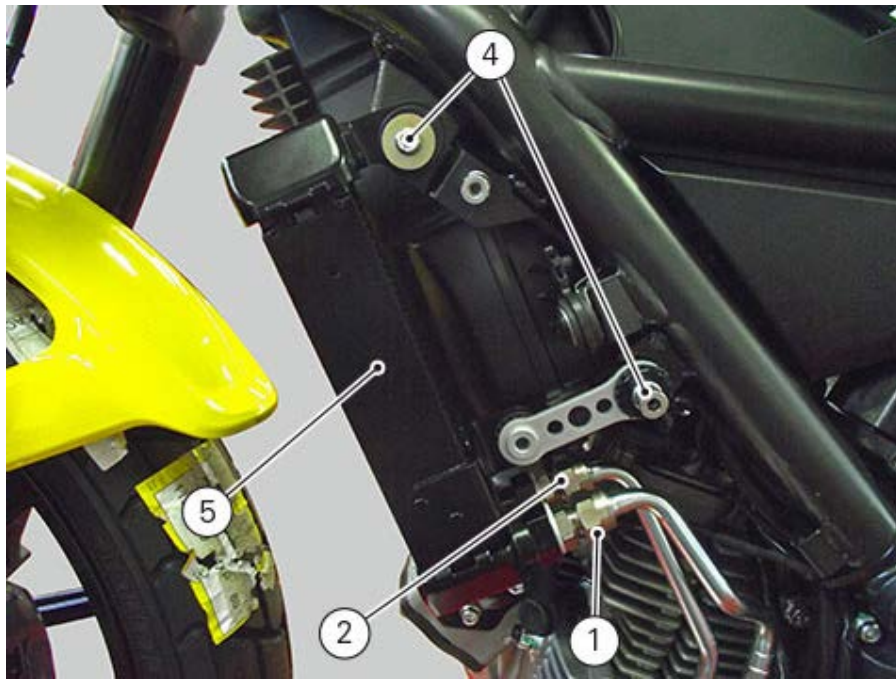

To remove the oil hoses (6) and (7), loosen the two nuts (8).
Loosen the two nipples (9) by recovering the relevant two gaskets (10).

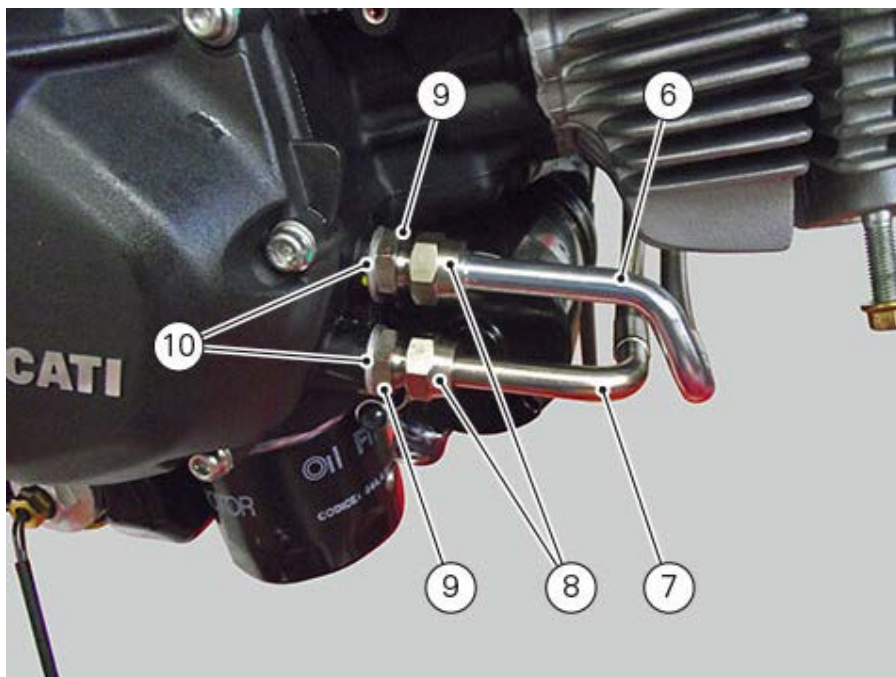

Checking the engine timing

Remove the spark plugs and install tool (A) no. **88765.1297** in the spark plug bore to determine the piston TDC, fit gauges (B) no. **88765.1581** and the timing check tool with degree wheel (C) no. **88713.0123**.

Set the opening valve clearance to zero when the camshafts are in rest position by fitting a feeler gauge, of suitable thickness, between the opening rocker arm and the opening shim.

Check that in this condition the camshaft can rotate. If it moves stiffly, use a thinner feeler gauge.

In this condition, with the piston of the horizontal cylinder at TDC with the valves fully closed as confirmed by the reading with gauge (A), set the gauges (B) to zero.

Tension the belts according to the value specified in paragraph "[Changing the timing belts](#)".

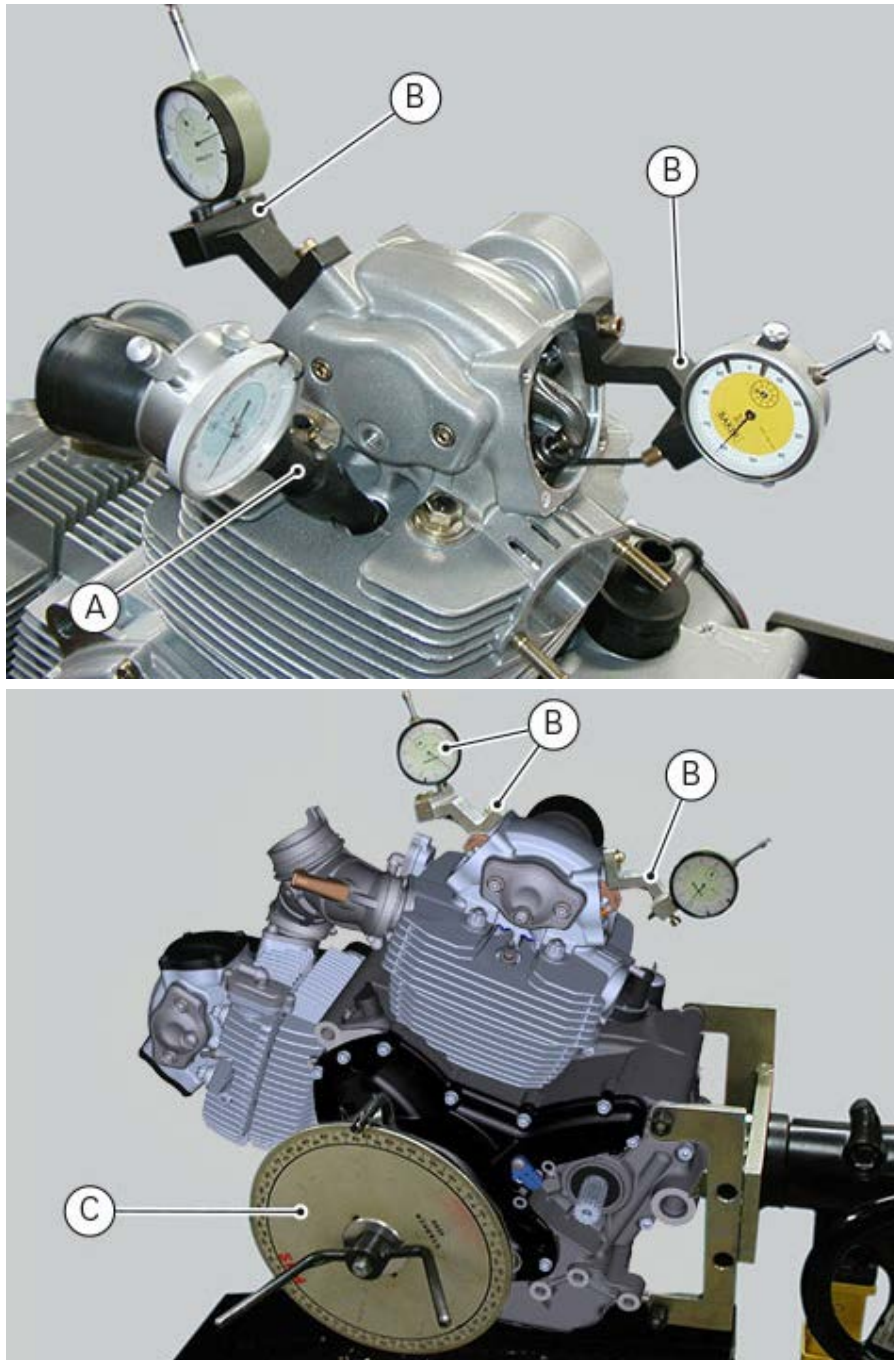

Turn the degree wheel (C) counter clockwise until the gauge dial (B), on the exhaust side, shows a lift of 1 mm.

Check that the value of the angular displacement read on the degree wheel (C) is the specified one.

Valve lift — valve clearance of 0 mm	Intake 11.20 mm Exhaust 10.80 mm
--------------------------------------	-------------------------------------

Timing diagram with valve clearance of 1 mm	Intake	Opening 4° B.T.D.C. Closing 66° A.B.D.C.
	Exhaust	Opening 61° B.T.D.C. Closing 7° A.B.D.C.
Intake valve diameter	44 mm	
Exhaust valve diameter	38.5 mm	

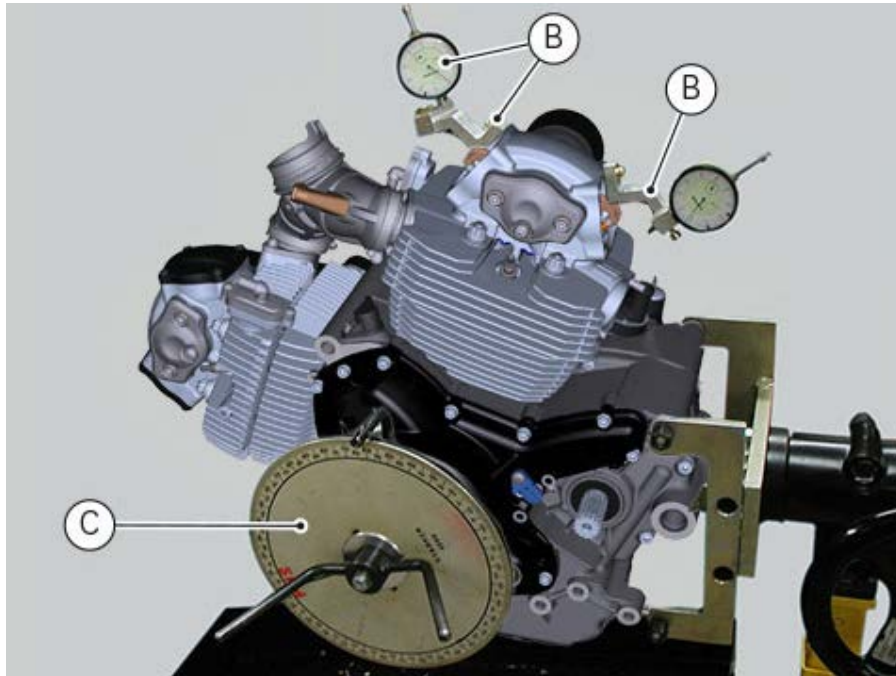

Continue to rotate in the same direction until you obtain a lift of **1 mm** on the intake side.
 Check the angular value on the degree wheel.
 Continue to rotate until you obtain an intake valve lift of **1 mm** on the gauge (B), during closure of the valve for the compression stroke.
 Check the angular displacement value with the specified one.
 Continue to rotate the degree wheel counter clockwise until you obtain a lift of **1 mm** of the exhaust valve, when opening or closing the valve.
 Check the angular displacement value against the specified value.
 Repeat the procedure for the vertical cylinder.
 A tolerance of $\pm 3^\circ$ is allowed in the values detected with the described procedure compared to the specified ones.

Checking valve lift

Fit gauge (A) part no. **88765.1581** in the hole of the removed head cover as shown in the figure. Set the opening valve clearance to zero when the camshafts are in rest position by fitting a feeler gauge, of suitable thickness, between the upper rocker arm and the opening shim.

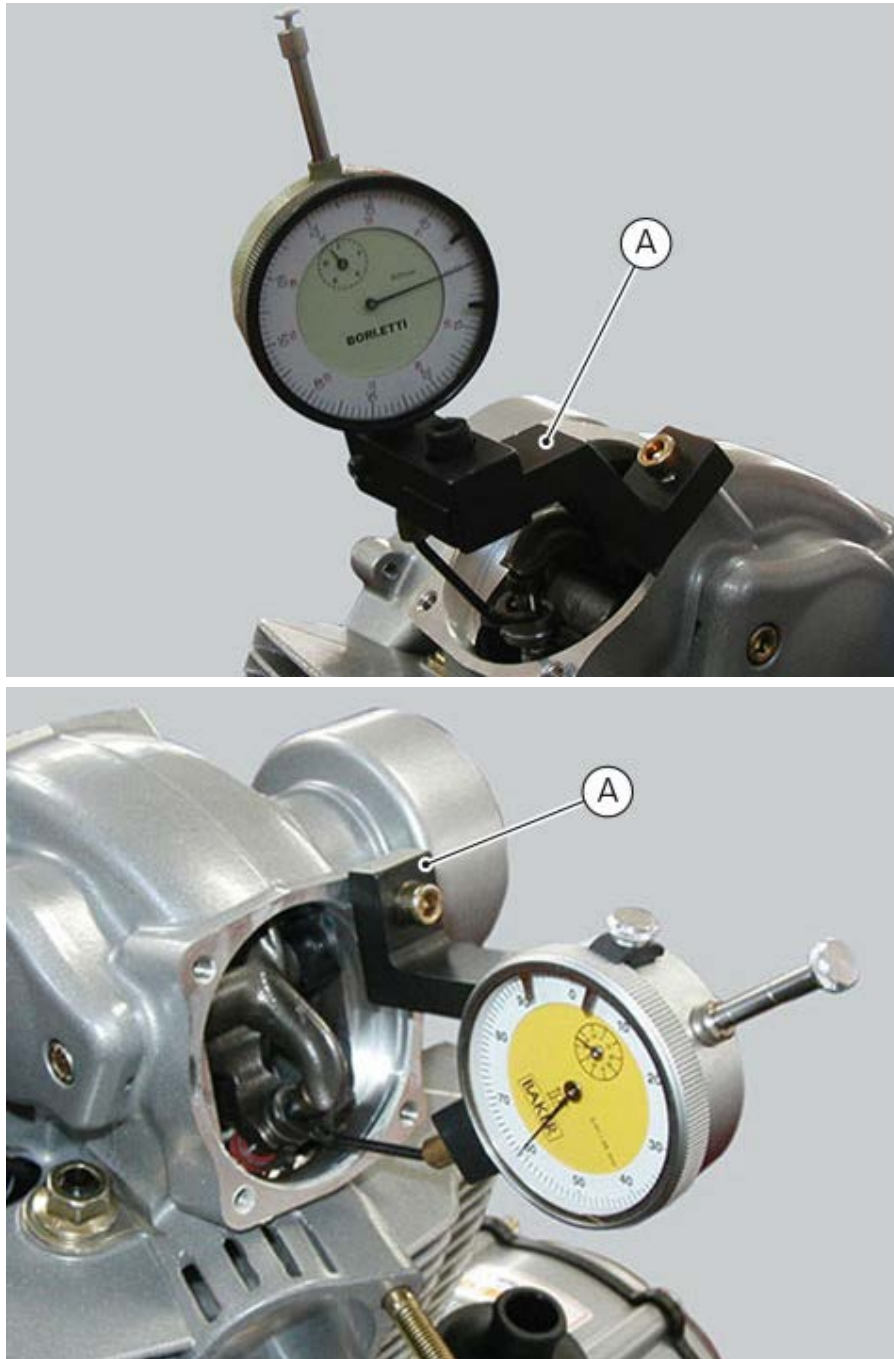

Check that the feeler gauge fork probe is centred on the valve axis and against the closing shim collar. Set the dial gauge to zero when the valve is fully closed.

Rotate the intake camshaft so as to allow the intake valves to lift fully.

Check on the dial gauge that the measured value corresponds to the prescribed one.

Perform the same operation for the exhaust valve, by fixing the support on the cylinder head opposite side.

Refit the components by carrying out the same operations indicated in paragraph "[Checking and adjusting the valves](#)" described above.

Valve lift — valve clearance of 0 mm	Intake 11.20 mm Exhaust 10.80 mm	
Timing diagram with valve clearance of 1 mm	Intake	Opening 4° B.T.D.C. Closing 66° A.B.D.C.

	Exhaust	Opening 61° B.T.D.C. Closing 7° A.B.D.C.
Intake valve diameter	44 mm	
Exhaust valve diameter	38.5 mm	

Checking and adjusting the valve clearance

Remove the seat ([Removing the seat](#)).

Remove the fuel tank ([Removing the fuel tank](#)).

Remove the blow-by ([Removing the airbox](#)).

Remove the following parts from the electrical component box:

- Battery;
- Starter relay;
- Fuse box;

Remove the cylinder head covers (1).

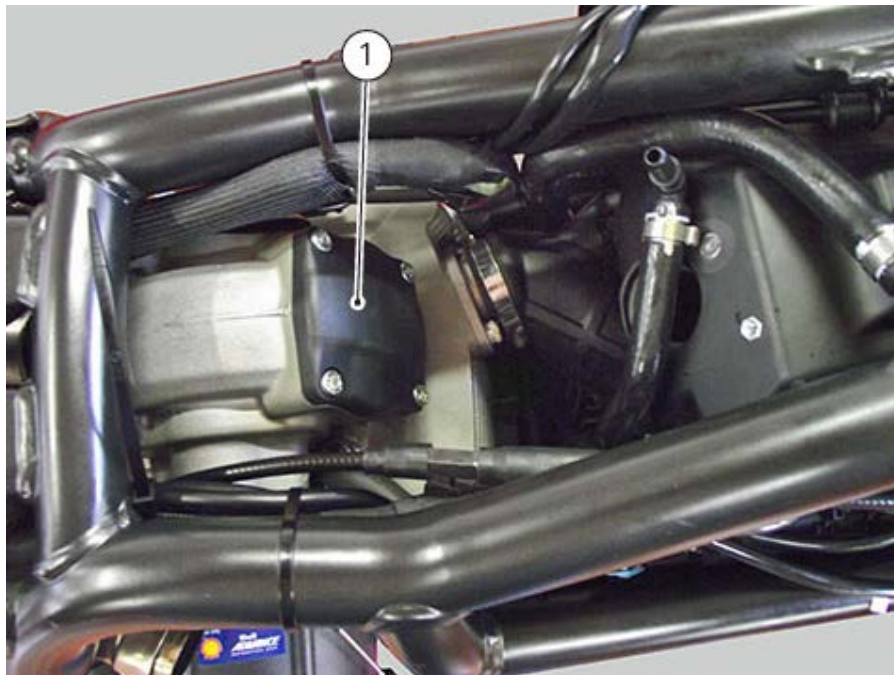
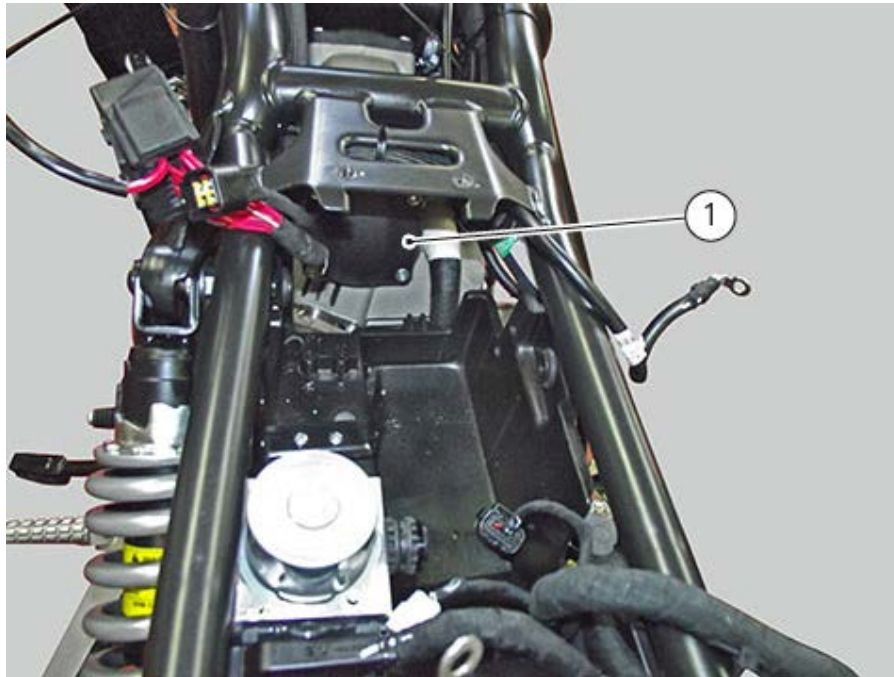

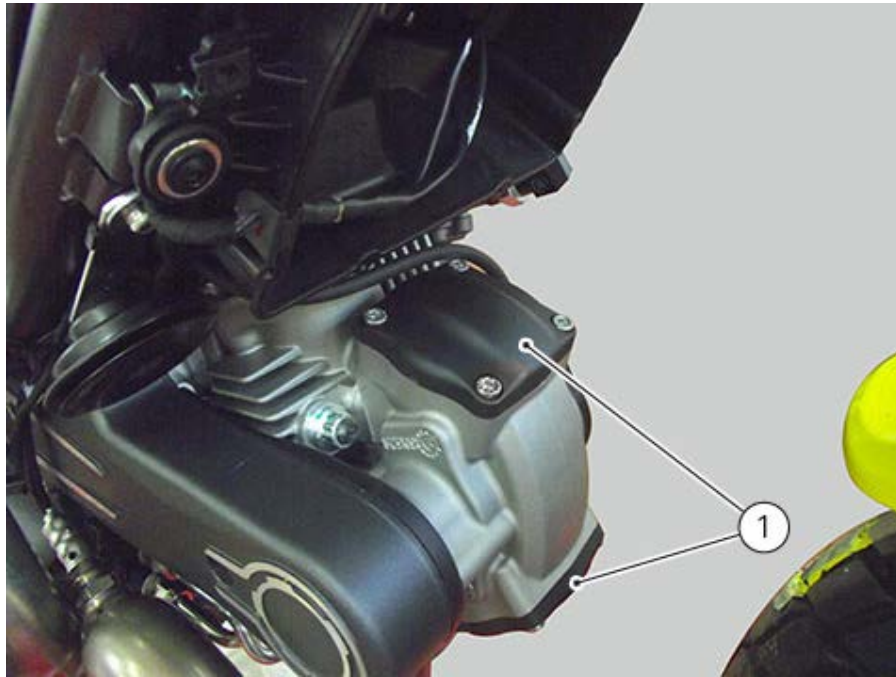

Fit tool part no. **88713.011** and ensure the two tool pins match the two slots on crankcase following the same procedure as for "[Changing the belts](#)". Turn the crankshaft so that the valve to be inspected is in rest position.

With the valve in the rest position, slide a feeler gauge between opening rocker arm and shim to measure the clearance. The clearance must be within the specified limits:

Opening rocker arm	
INTAKE	
Assembly	0.10÷0.15 mm
Inspection	0.10÷0.15 mm
EXHAUST	
Assembly	0.10÷0.15 mm
Inspection	0.10÷0.15 mm

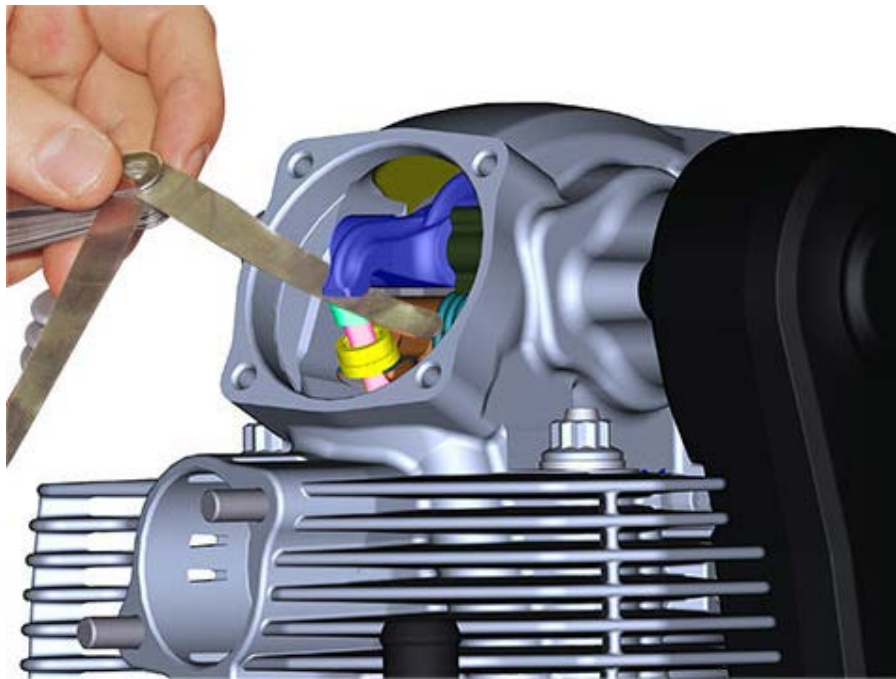

With the valve in the rest position, slide a feeler gauge between closing rocker arm and shim to measure the clearance.

Closing rocker arm	
INTAKE	
Assembly	0÷0.05 mm
Inspection	0÷0.05 mm
EXHAUST	
Assembly	0÷0.05 mm
Inspection	0÷0.05 mm

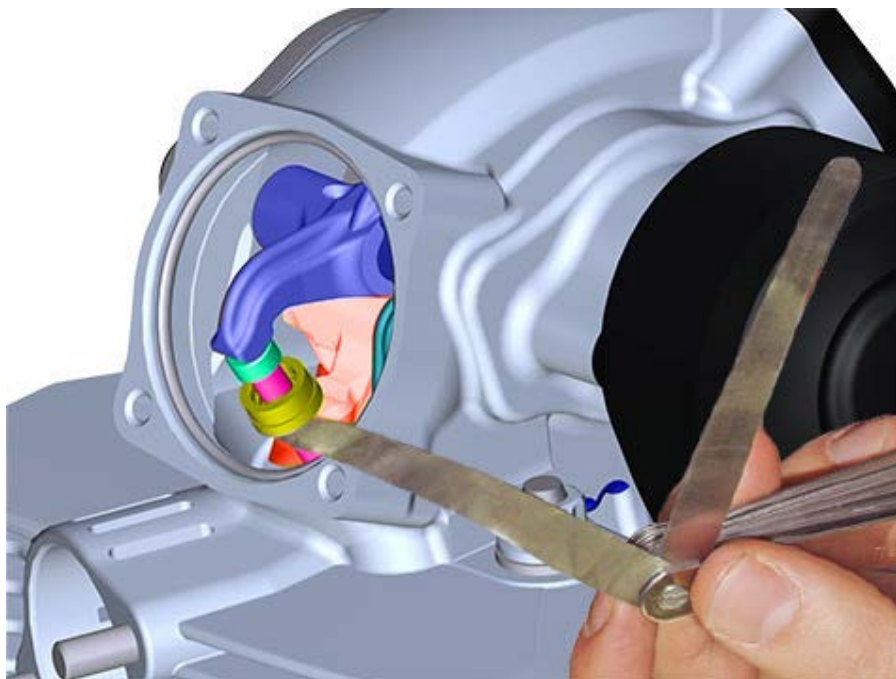

If detected values exceed the specified limits, replace opening and/or closing shims, as described in

paragraph "[Removing the valves and rocker arms](#)", with one featuring an adequate thickness to obtain the specified clearance.



Note

Opening rocker arm shims measuring from 1.8 to 3.45 and closing rocker arm shims from 2.2 to 4.5 are available as spare parts: the size is punched on the shim.

Reassemble the removed components in the removal reverse order.

Refitting the timing outer covers

Position the vertical timing belt cover (3) on the engine.

Start screw (1) on the cover.

Position the horizontal timing belt cover (2) on the engine.

Tighten the screws (1) to a torque of 10 Nm (Min. 9 Nm - Max. 11 Nm).

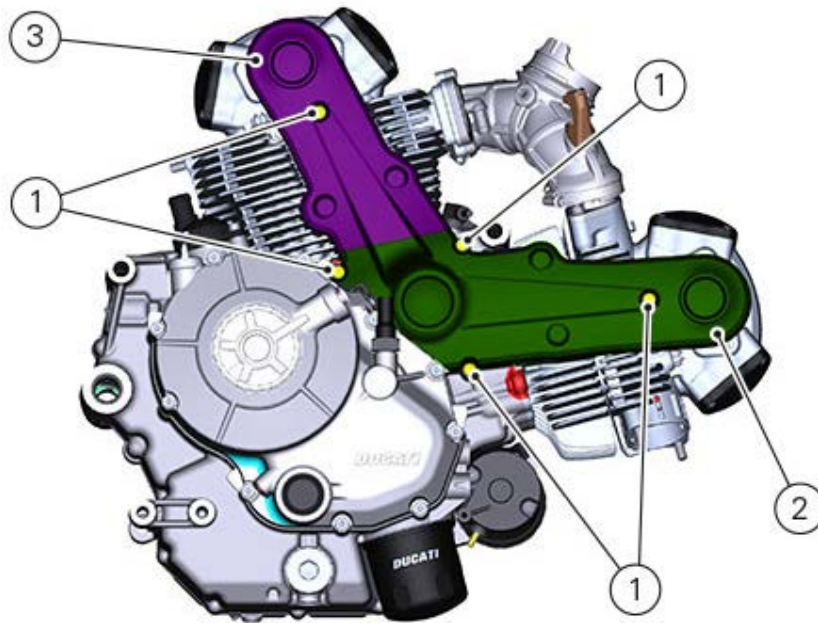

Refit the exhaust system ([Refitting the exhaust system](#)).

Refitting the timing belts

To refit the timing belts refer to paragraph "[Replacing the timing belts](#)".

Refitting the cylinder heads pulleys/idler pulleys

Fit snap ring (20) on the timing layshaft on the pulley side.
To guide it in its position, use protection cap no. **88700.5749** and the supplied drift.



Fit spacer (19) with the recess facing the casing.
Position the first keyway (18), the internal pulley (17), the guide washer (16) and the second keyway (15) on the timing layshaft.

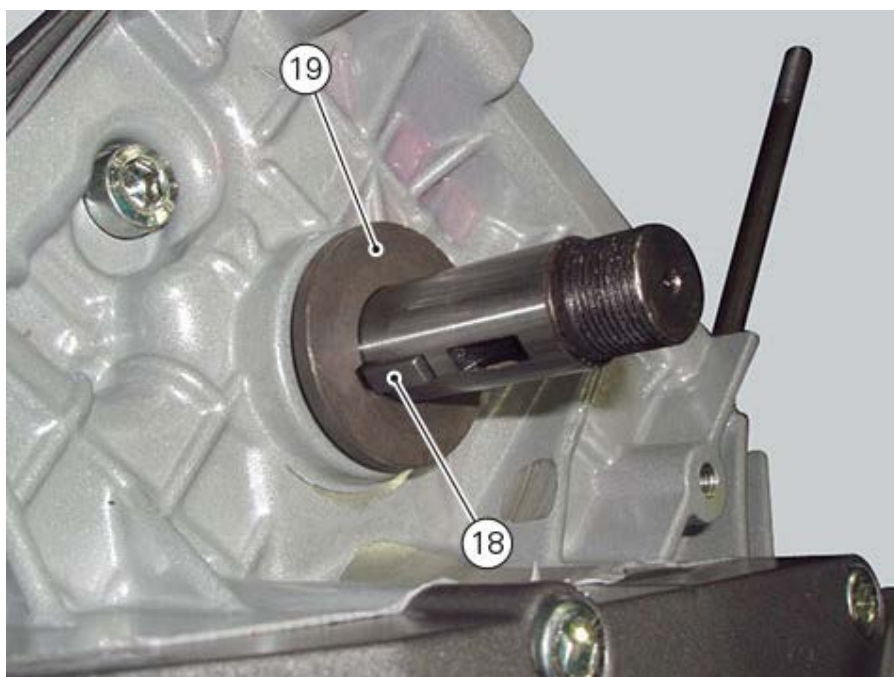

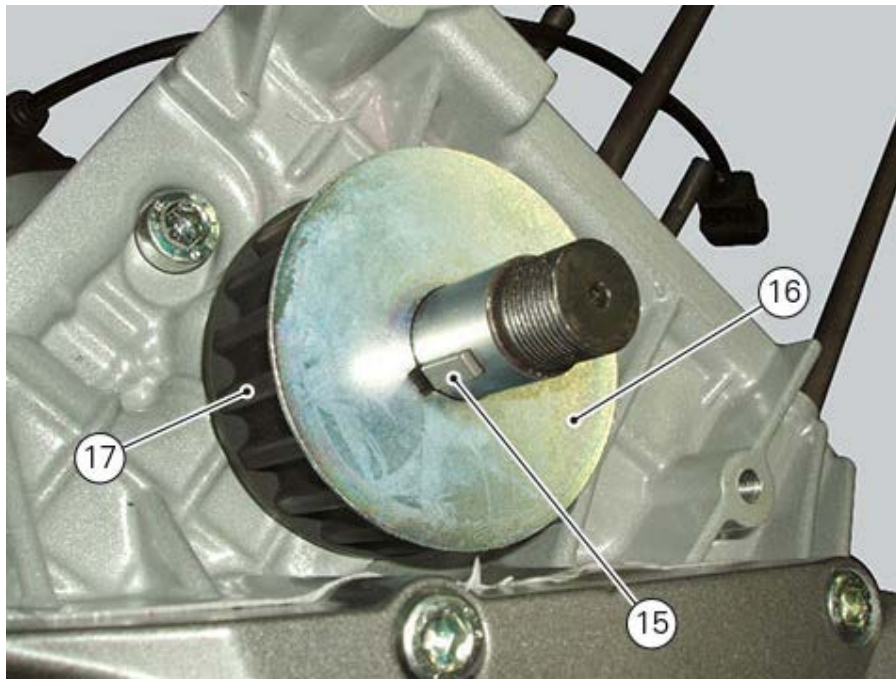

Then fit the external pulley (14) of the external spacer (13) and of the lock ring nut (12).

Important

To prevent the ring nuts from loosening and consequent serious engine damage, always use new self-locking ring nuts on all the timing pulleys.

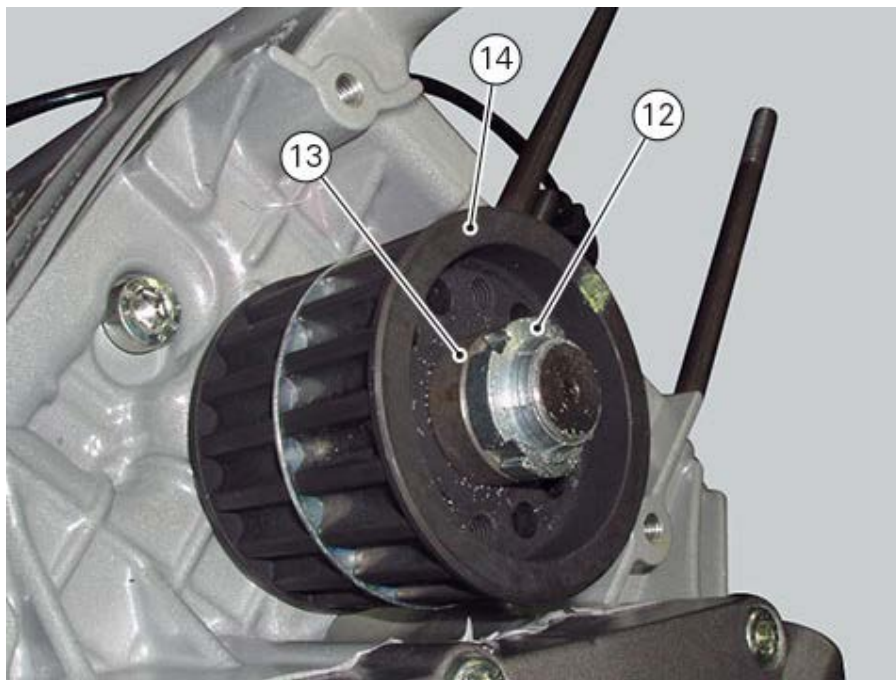

Block with the key of tool (A) no. **88700.5644** the pulley rotation and use the bush inserted in a torque wrench to tighten the self-locking ring nut to a torque of 71 Nm (Min. 64 Nm - Max. 78 Nm).

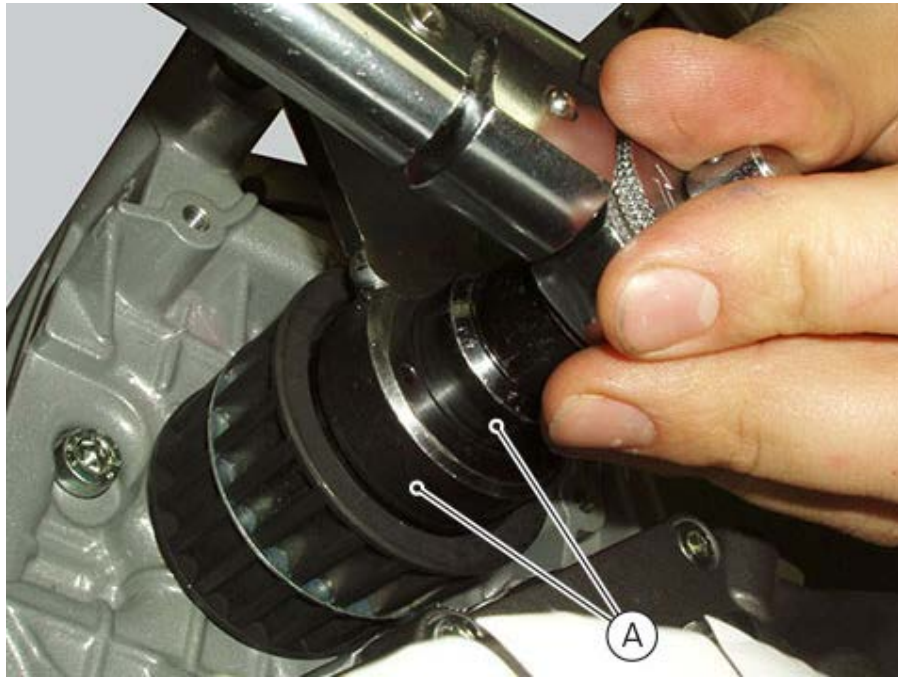

Reassembling the timing pulleys

For the reassembling operation, fit pulley (23) on hub (24), making the pulley reference point (A) coincide with the hub reference mark (B).

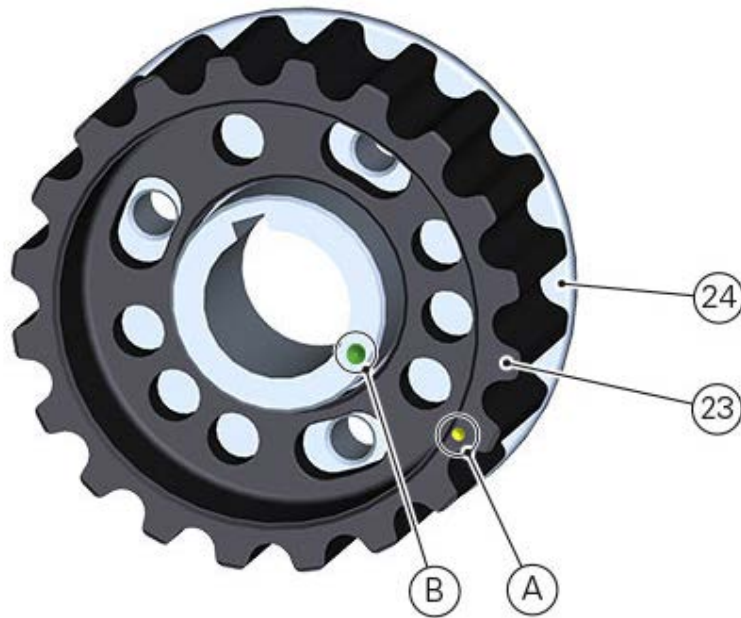

Fit washer (22) fully home on the pulley, aligning the reference notch (C) with pulley reference point (A) and hub reference mark (B).
Tighten screws (21) in the hub threaded holes.

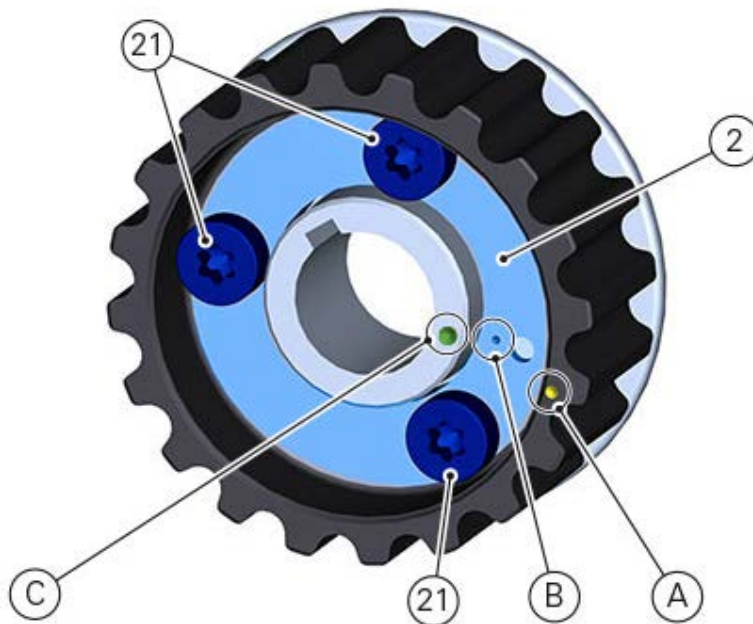

Refitting the timing layshaft pulley

If it has been removed, apply specified threadlocker to fixed tensioner (11) and tighten it to a torque of 20 Nm (Min. 18 Nm - Max. 22 Nm).

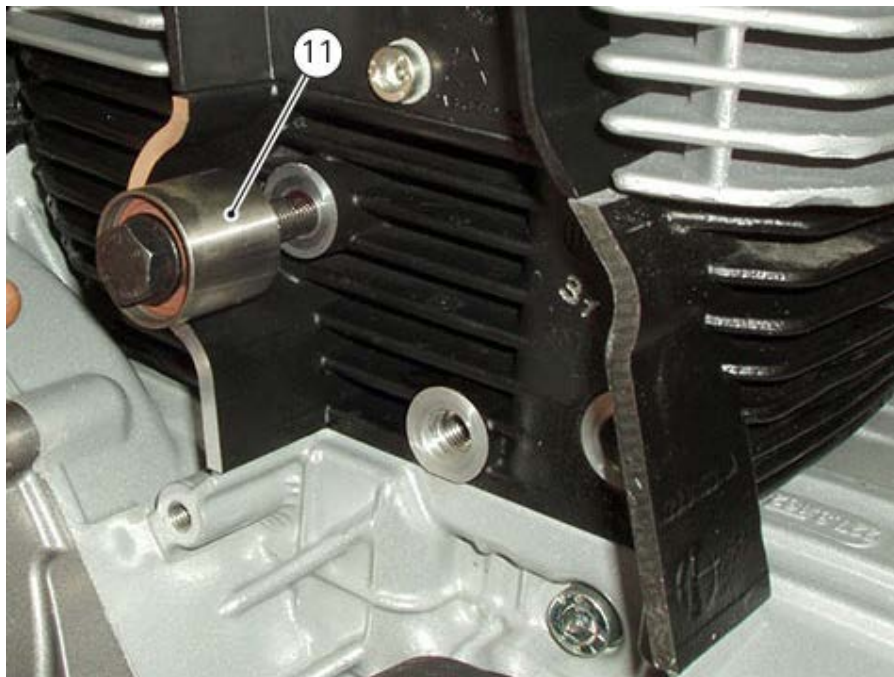

Check that the tab seat on the end of the camshaft is in good condition and without burrs. Fit a key (1) in the keyway of the camshaft.



Fit the pulley assembly (10) on the camshaft and push it fully home.



Warning

Ensure that the keyway does not accidentally slip out of its seat.

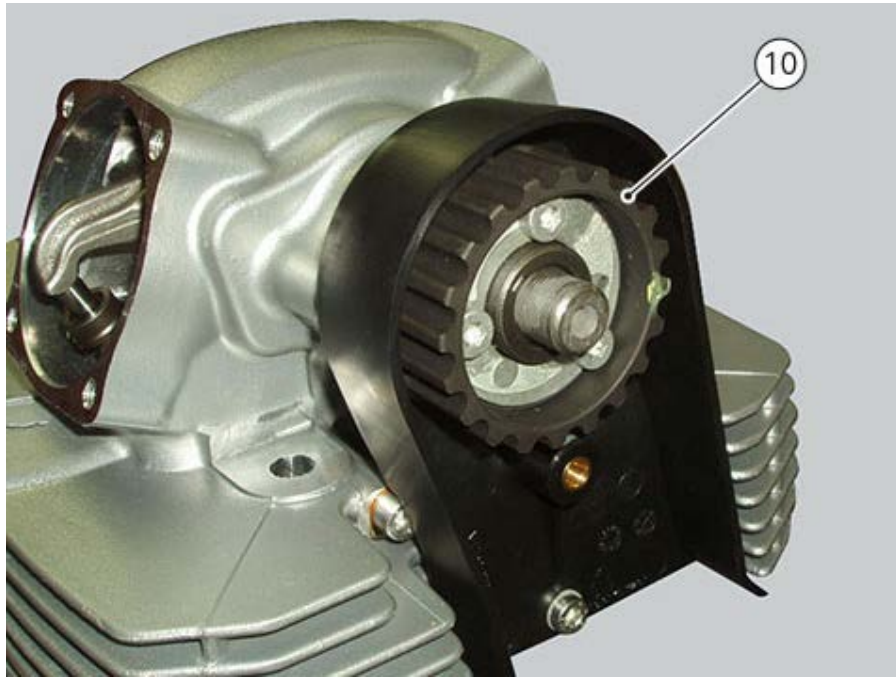

Insert tool **88713.3152** in the pulleys to block its rotation.

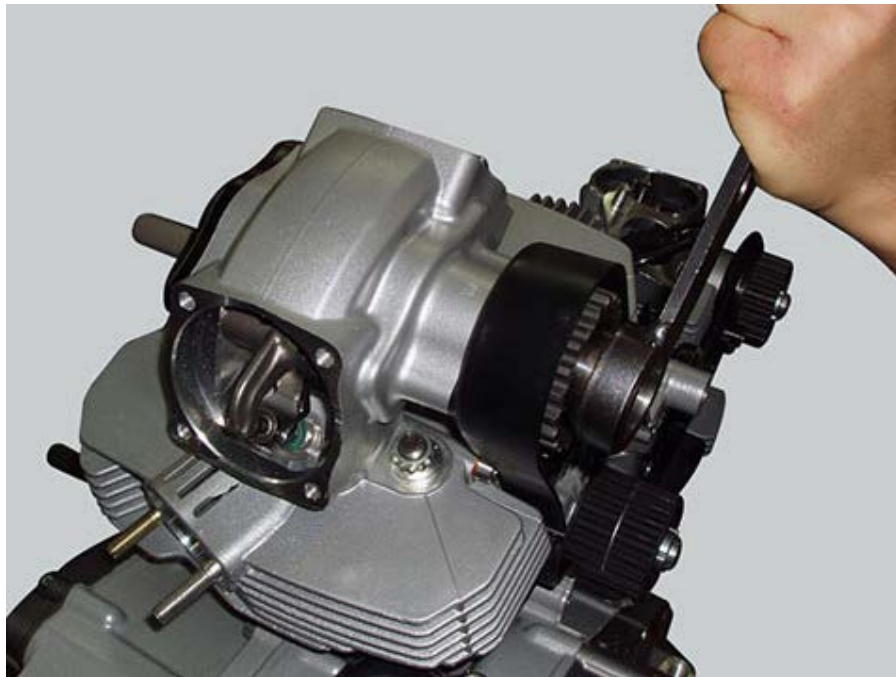

Apply a thin layer of specified grease on the thread and on the underhead of ring nut (8), fit washer (9) and the ring nut.



 **Important**

Always fit new nuts on reassembly.

Use the bush of tool no. **88700.5644** and a torque wrench to tighten ring nuts (8) to 71 Nm (Min. 64 Nm - Max. 78 Nm).

Removing the timing layshaft pulleys

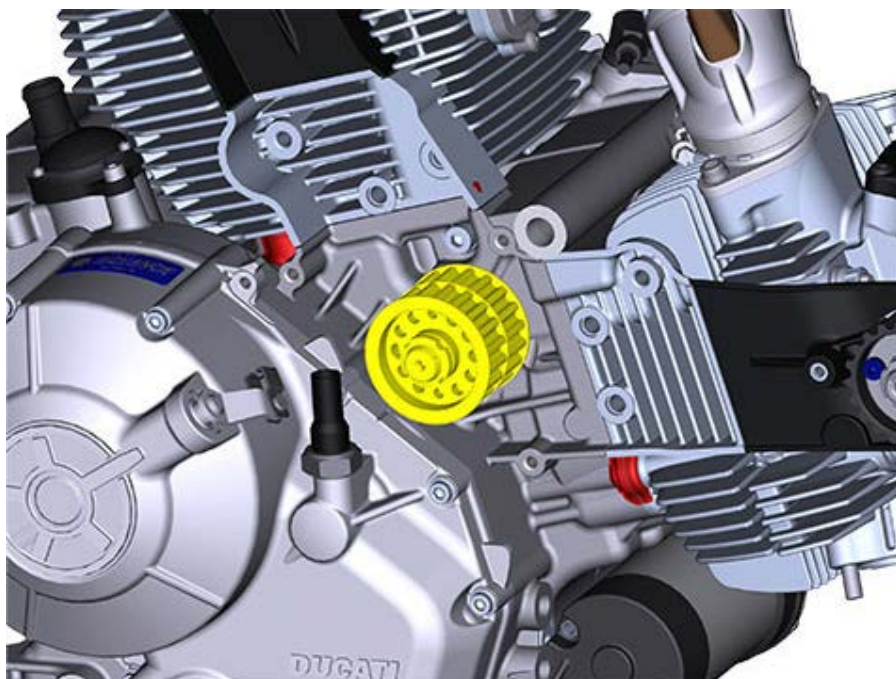

Block with the key of tool (A) no. **88700.5644** the driving pulley rotation on the crankcase and use the tool bush to loosen the retaining ring nut (12).
Remove ring nut (12), washer (13) and the outer pulley (14).



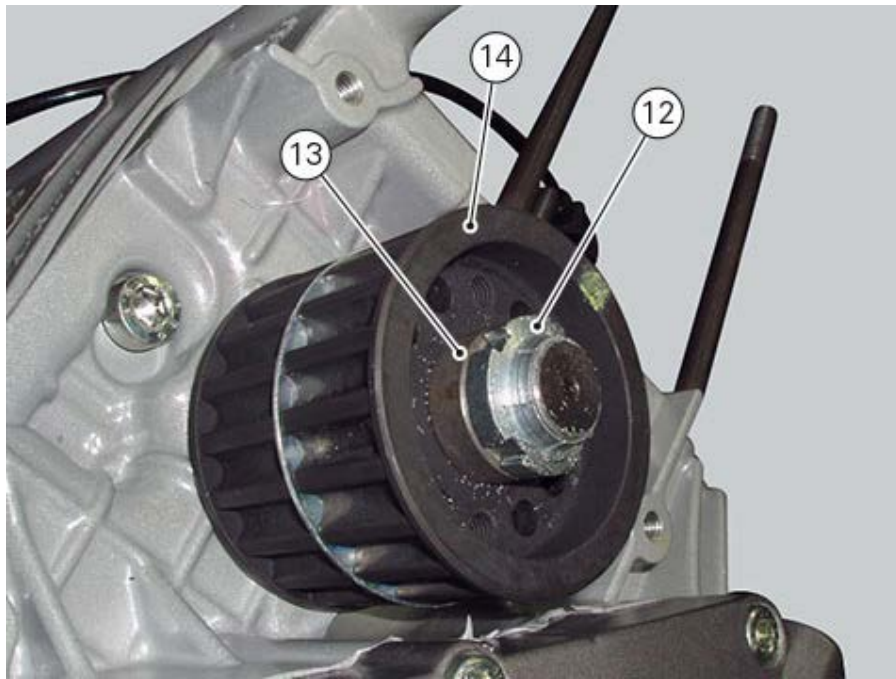

Remove the first key (15) located on the timing layshaft.
Remove the spacer (16) and the inner pulley (17).

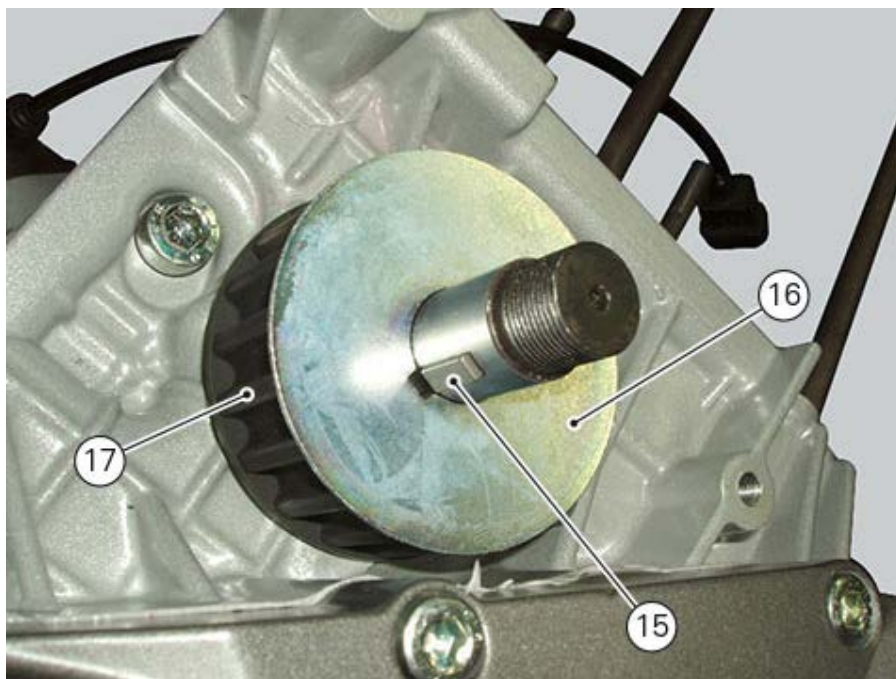

Remove the second key (18) located on the timing layshaft.
Remove spacer (19) and snap ring (20).

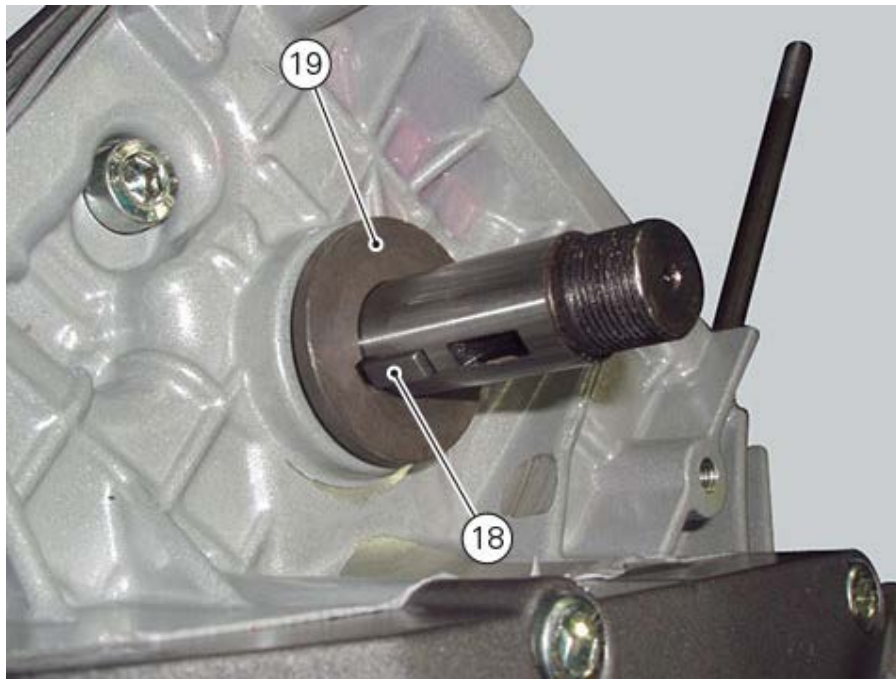

Disassembling the camshaft pulleys

To disassemble the pulley, loosen and remove the three screws (21), slide out washer (22) and pulley (23) from flange (24).

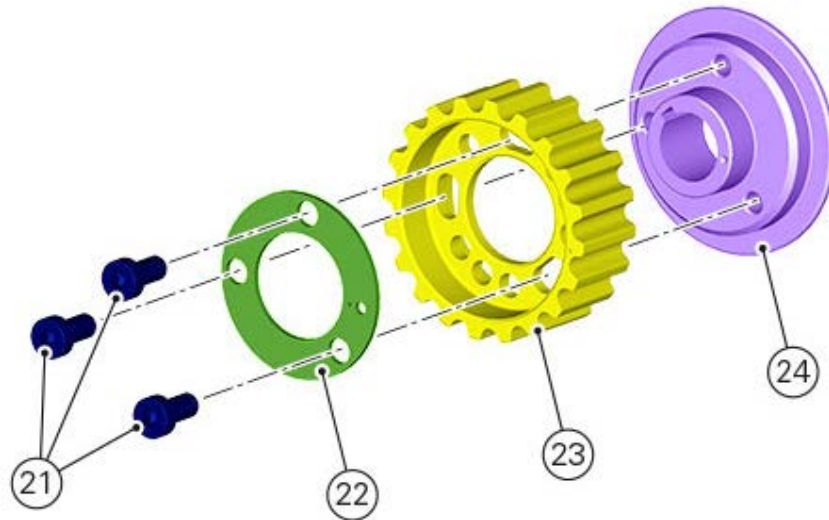

Removing the cylinder head pulley/fixed tensioner

To remove the head pulleys fit tool part no. **88713.3152** on the pulley to block its rotation and use the bush of tool part no. **88700.5644** inserted in a torque wrench or a ratchet wrench to loosen ring nut (8) that retains the pulley.



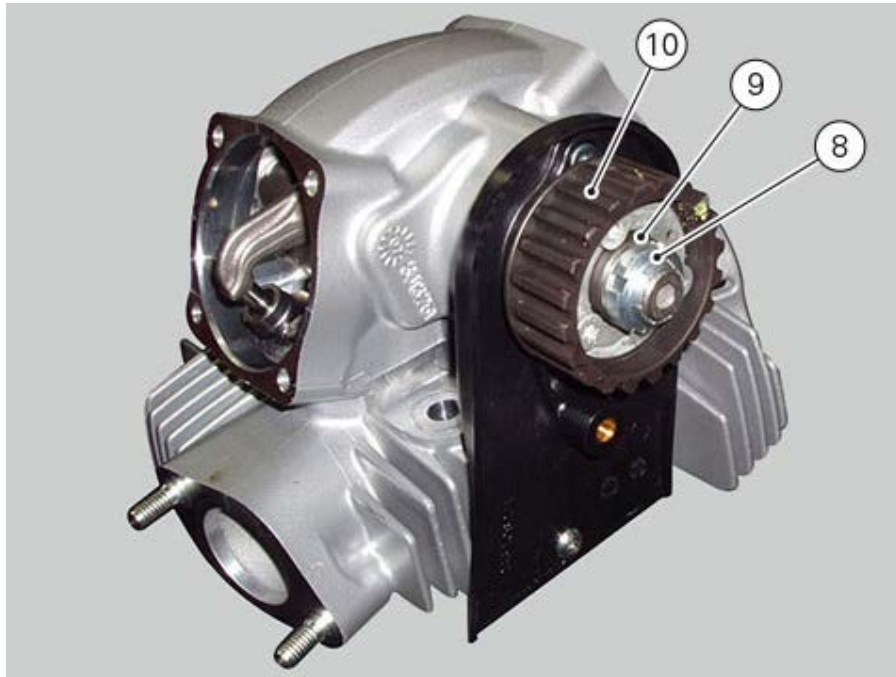

Important

Upon reassembly, always use new ring nuts.

Loosen and remove the fixed tensioners (11).

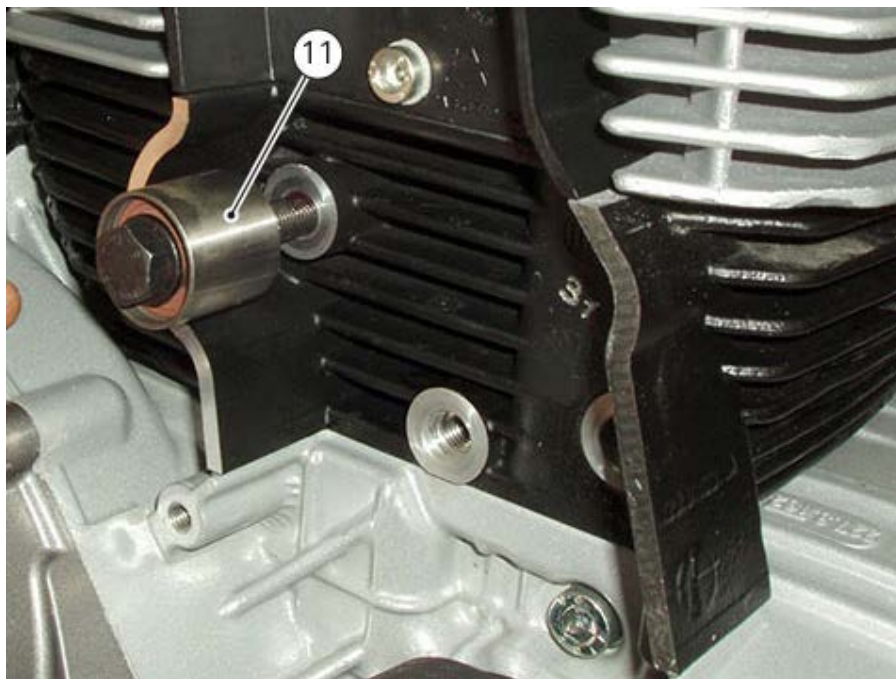

Removing the mobile tensioner/timing belt

Loosen positioning screw (4) of the horizontal cylinder belt mobile tensioner (5).
Loosen retaining screw (6) of tensioner (5) and bring it to its rest position.
Remove the timing belt (7).

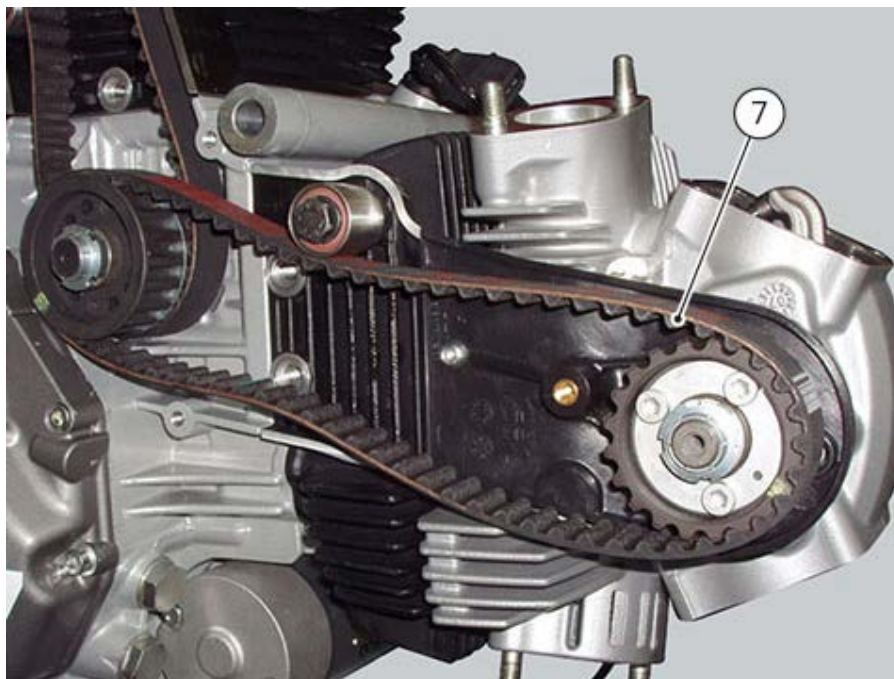
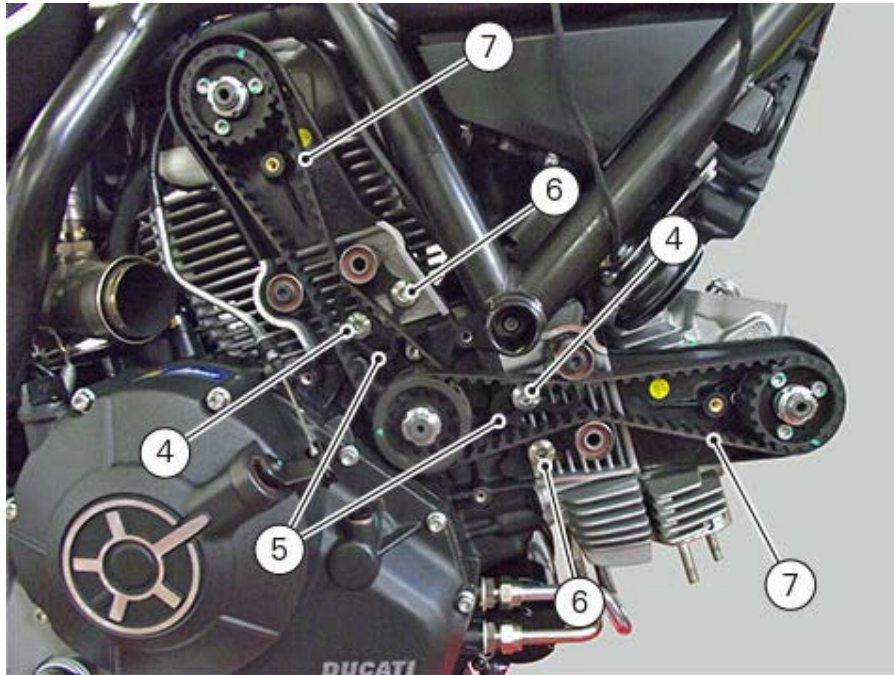

Perform the same operation sequence to remove the vertical cylinder timing belt.

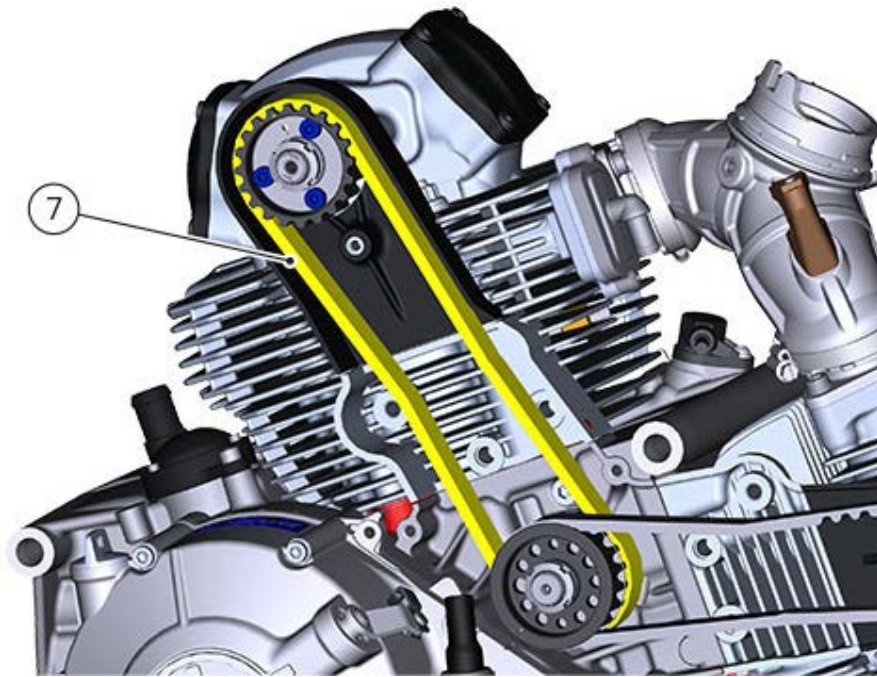
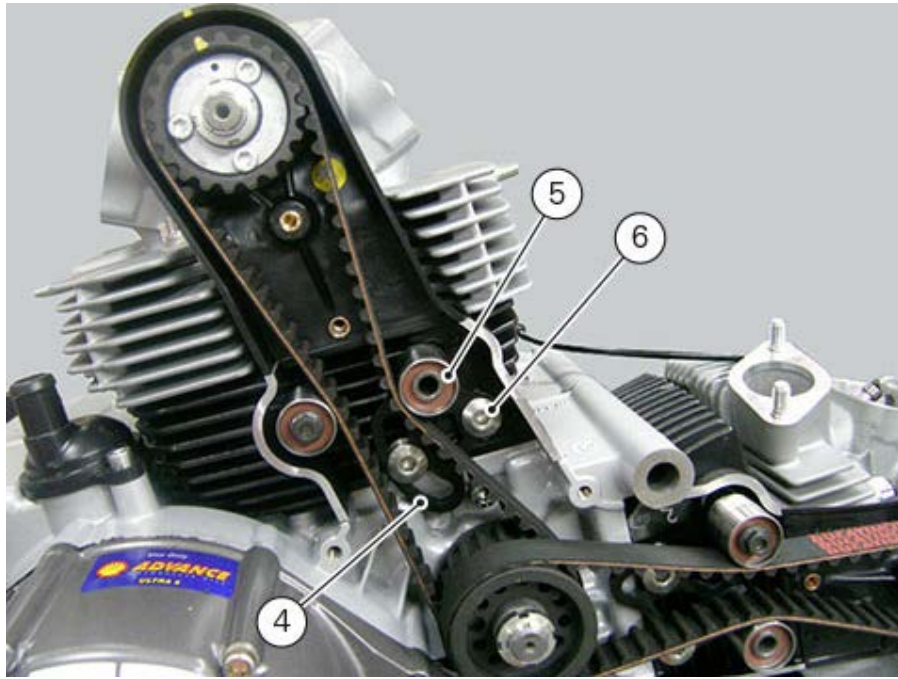

Removing the timing belt covers

Remove the seat ([Removing the seat](#)).

Remove the exhaust system ([Removing the exhaust system](#)).

Loosen screws (1) and remove the external cover (2) of the horizontal timing belt. Loosen screws (1) retaining the external cover (3) of the vertical timing belt and remove it.

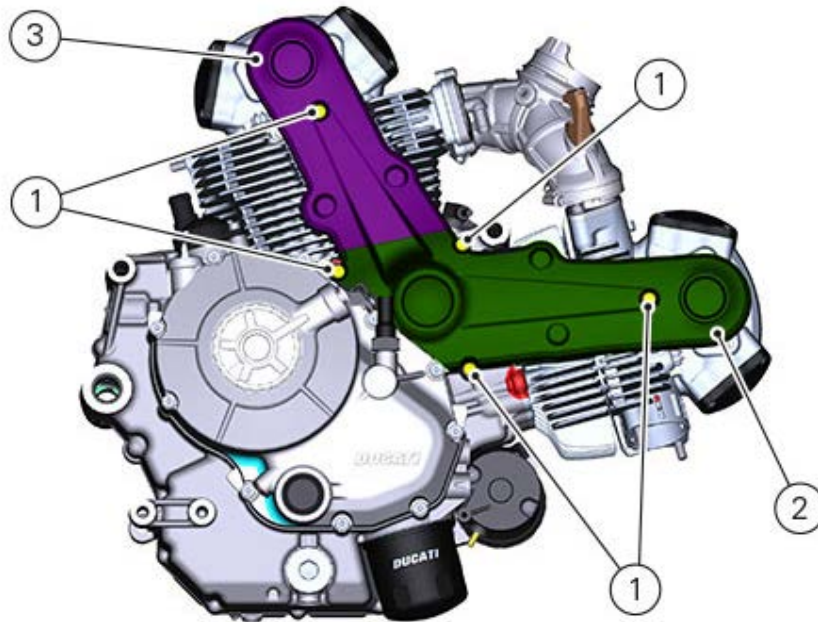

Refitting the intake manifold

Position intake manifolds (3) and fix them using nuts (2).
Tighten nuts (2) to a torque of 15Nm (Min. 13Nm - Max. 17Nm).

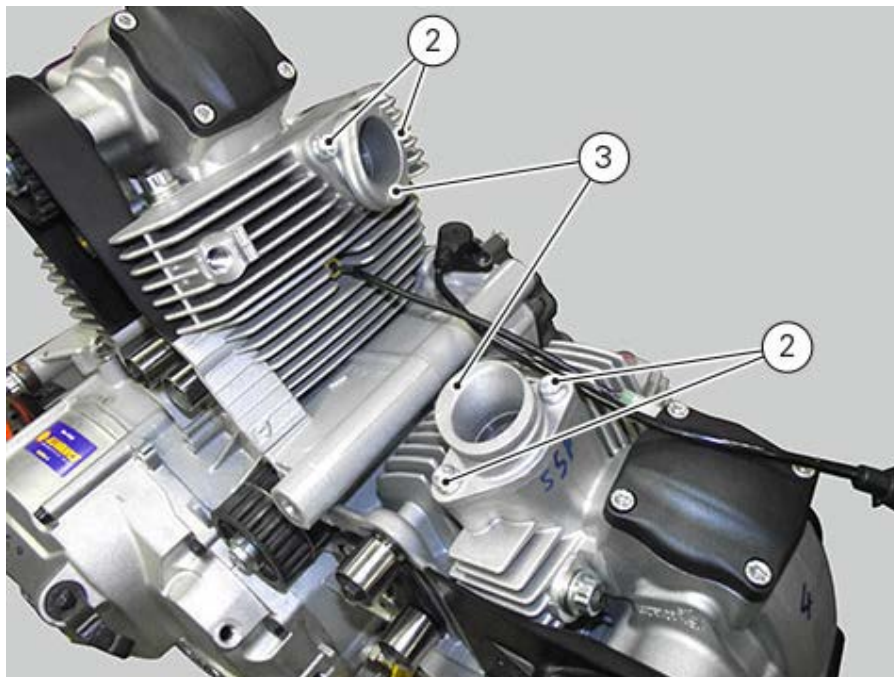

Refit the engine in the frame.

Removing the intake manifold

Remove the engine from the frame.

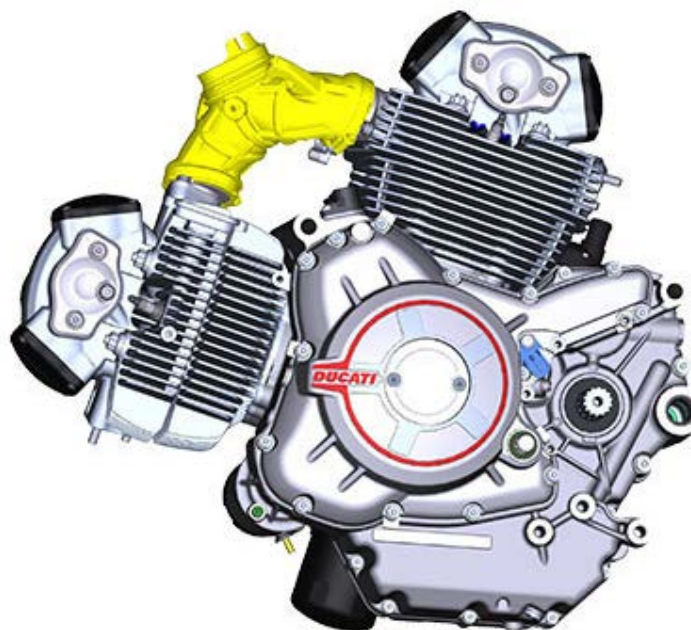

Loosen clamp (1) of the vertical head intake manifold.

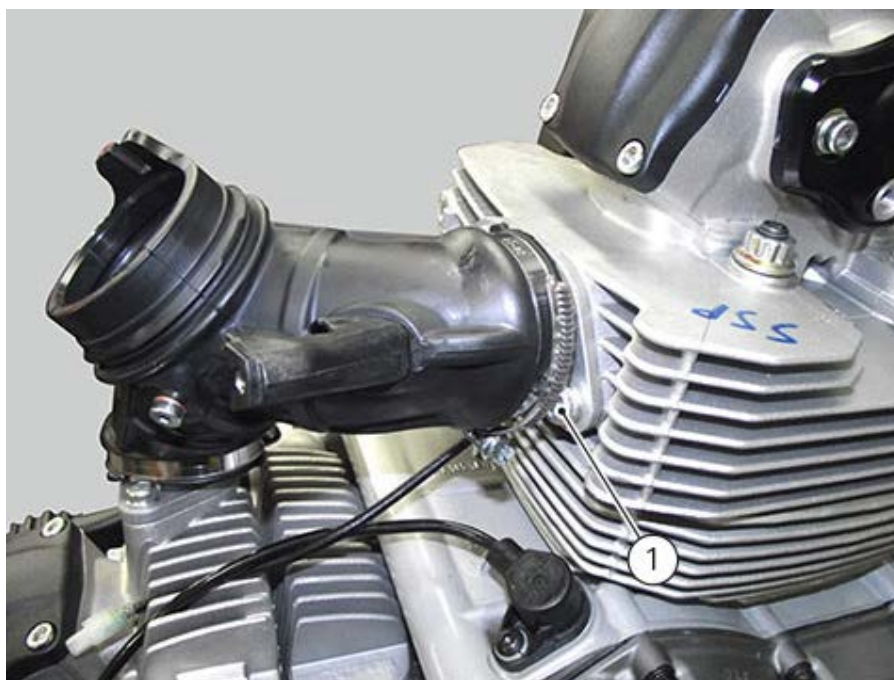

Repeat the same procedure on the horizontal head.



Remove intake manifold.



Loosen and remove nuts (2) securing the vertical and horizontal head intake manifolds.
Remove manifolds (3).

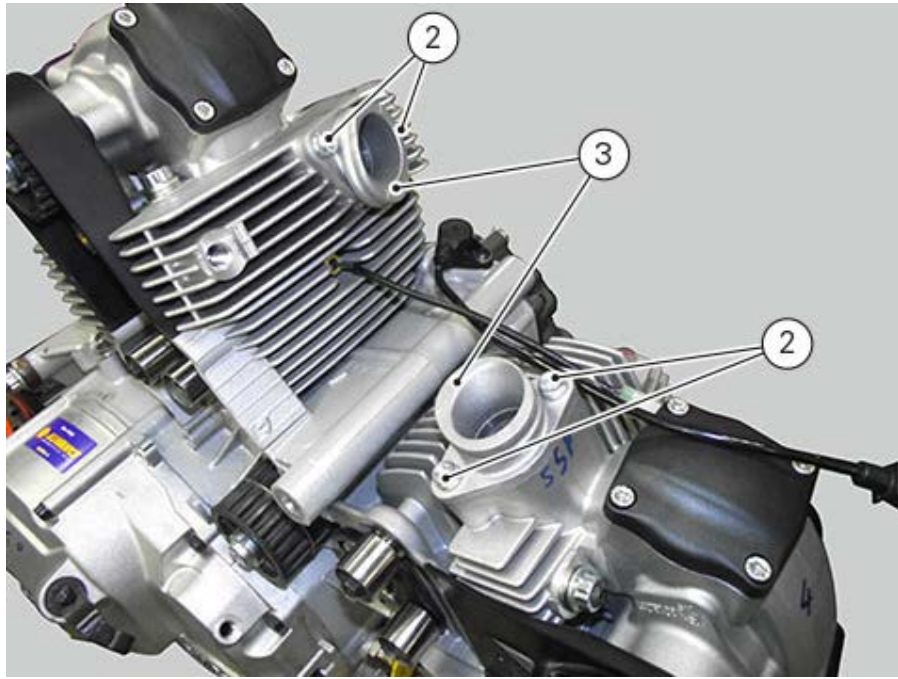

Refitting the camshafts

If previously removed, fit seal (12) in its seat on the cylinder head right side using a suitable drift.

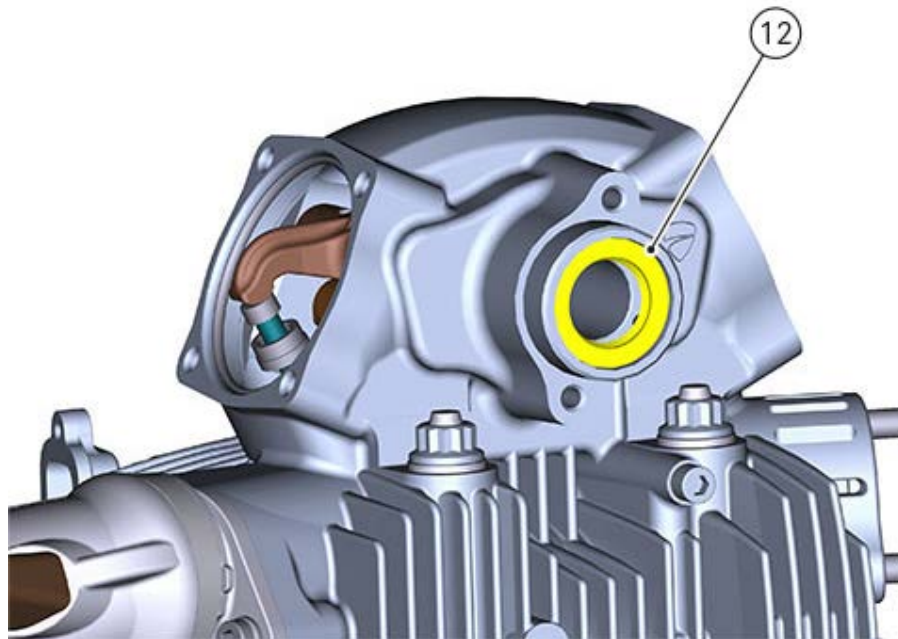

Important

If valve rocker arms are installed in the cylinder head, to insert the camshaft it is necessary to rotate the camshaft until the cams reach a position that does not interfere with the rocker arms.

Before fitting the camshaft, check the punched letter on the shaft: "V" stays for vertical whereas "O" stays for horizontal.



Lubricate the camshaft seats and "tank" (13) and (A) so that during the first engine rotations the camshaft is lubricated.

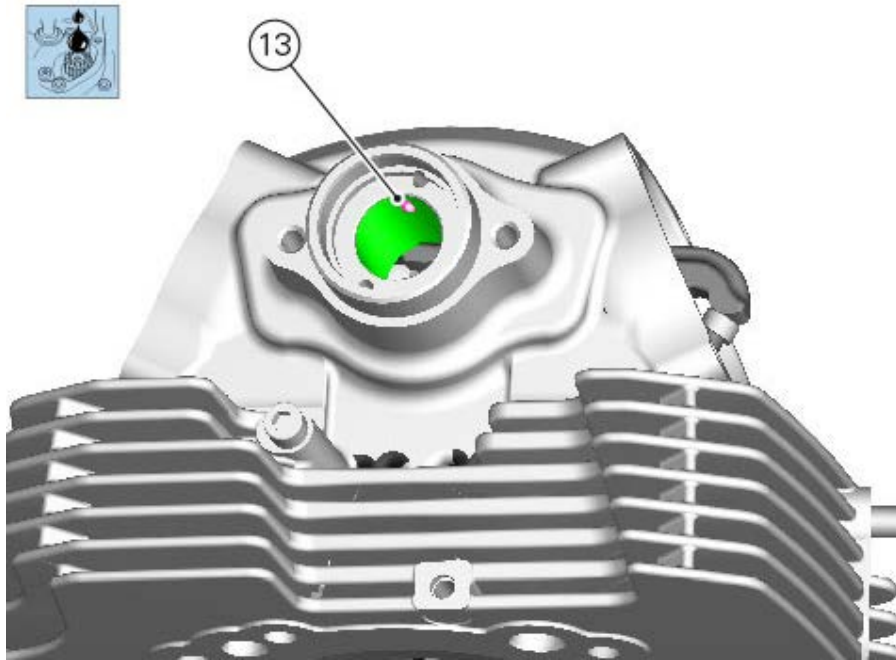

Fit the camshaft (11) from the head LH side.

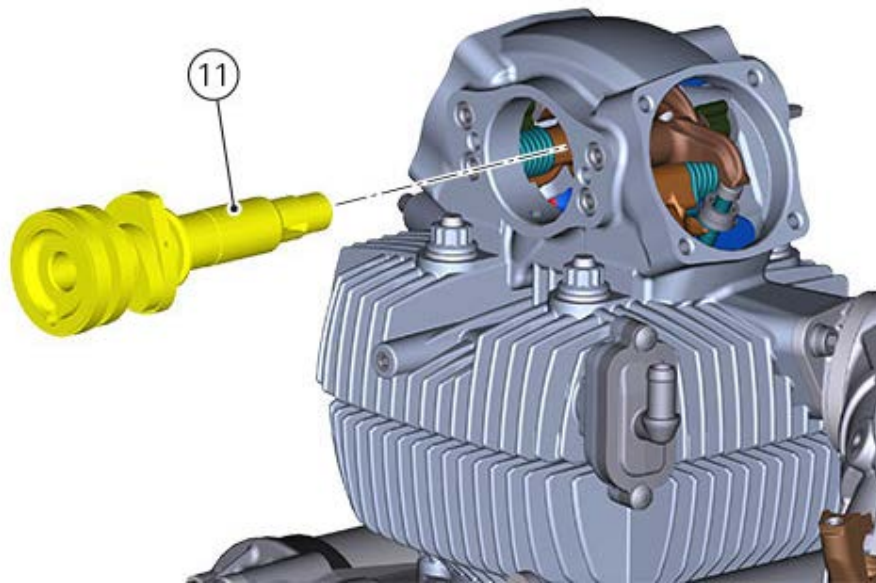

While fitting the camshaft, pay attention not to damage the seal.

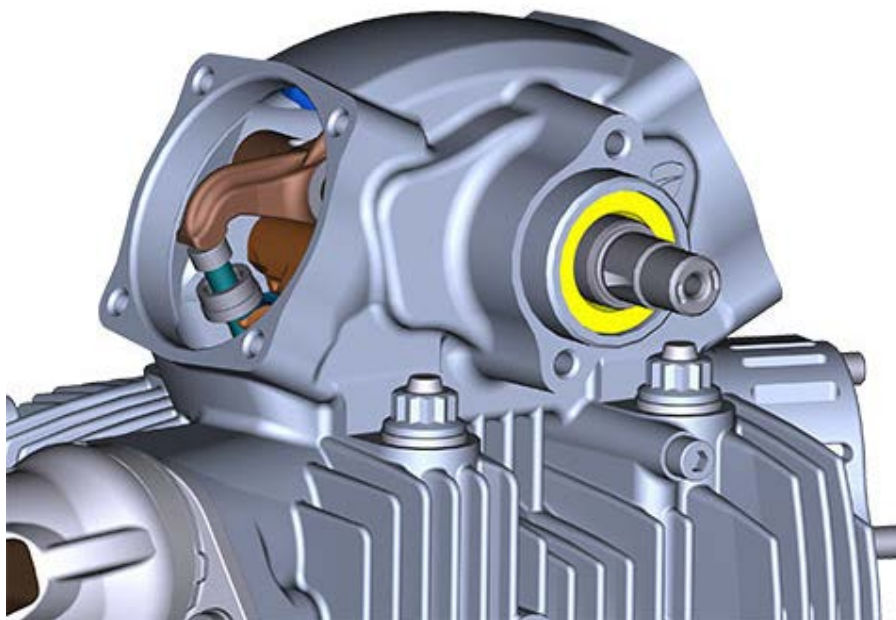

Rotate camshaft to evenly lubricate contact areas.

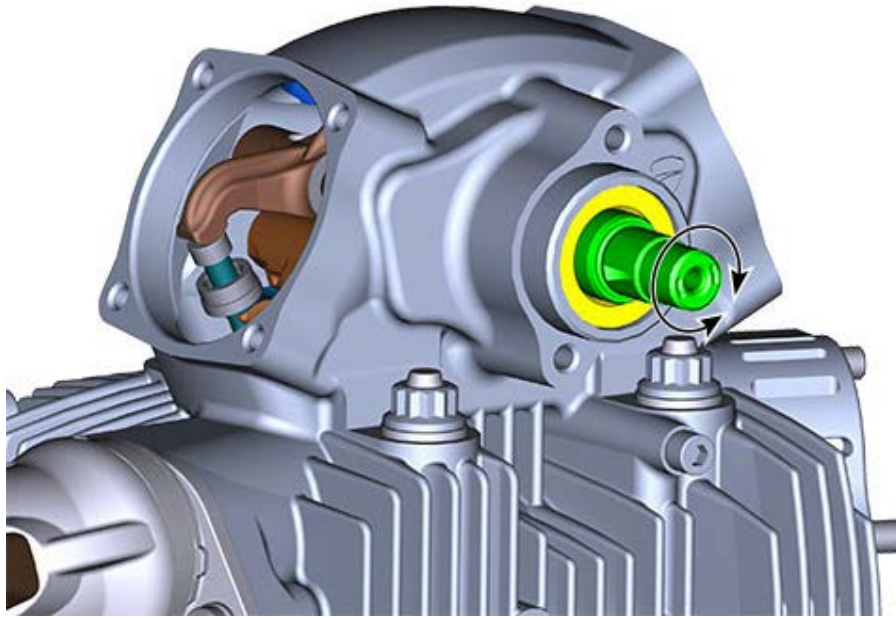

If previously removed, reposition spring (9) of the opening rocker arm (10).

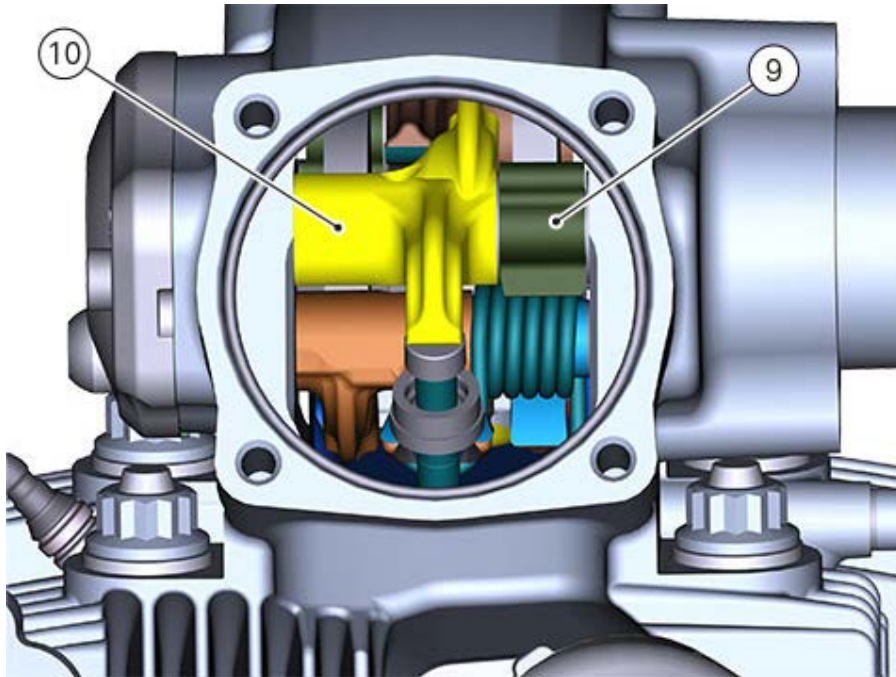

Check the key (7) and its seat conditions and then refit it.

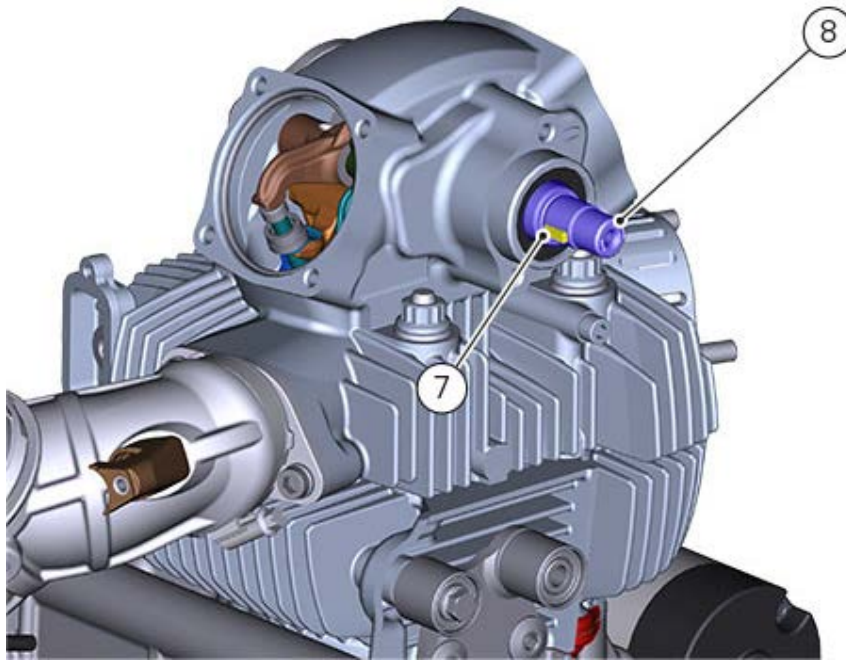

Refitting the side caps

Position cap (6) on the cylinder head LH side.

Fasten cap (6) with screws (5) after applying indicated threadlocker.

Tighten the screws (5) to a torque of 13.5 Nm (Min. 12.5 Nm - Max. 14.5 Nm) following a 1-2-1 sequence

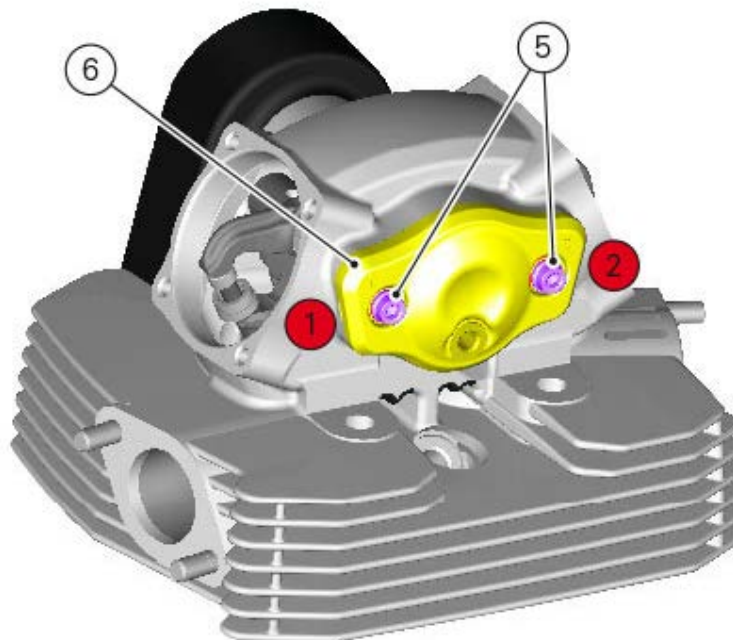

Fitting the timing internal cover

Position cover (4) and tighten screws (3) to a torque of 10 Nm (Min. 9 Nm - Max 11 Nm).

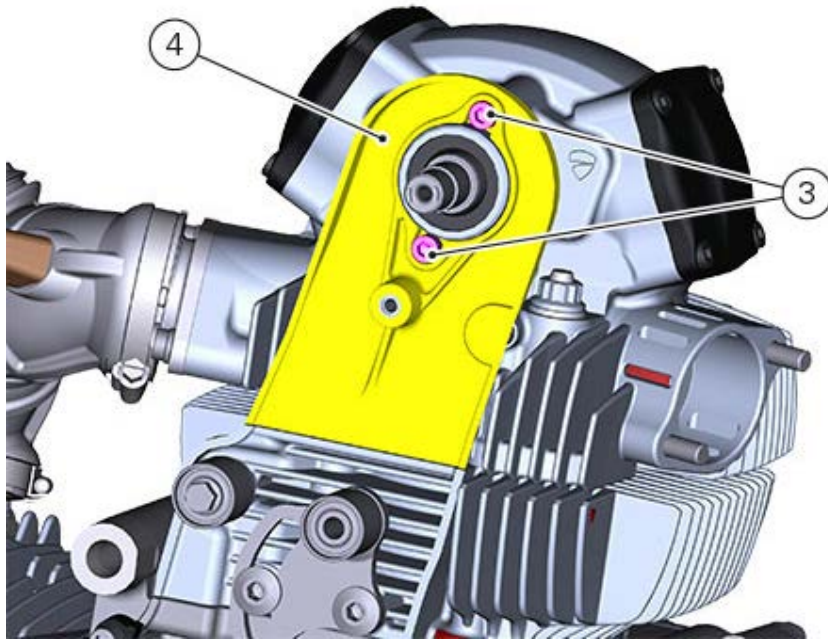

Refitting the valve covers

Fit O-ring (A) in the suitable seat on the valve cover (2).

Lubricate the O-ring with the indicated product.

Position cover (2) and start screws (1) to a torque of 10 Nm (Min. 9 Nm - Max 11 Nm).

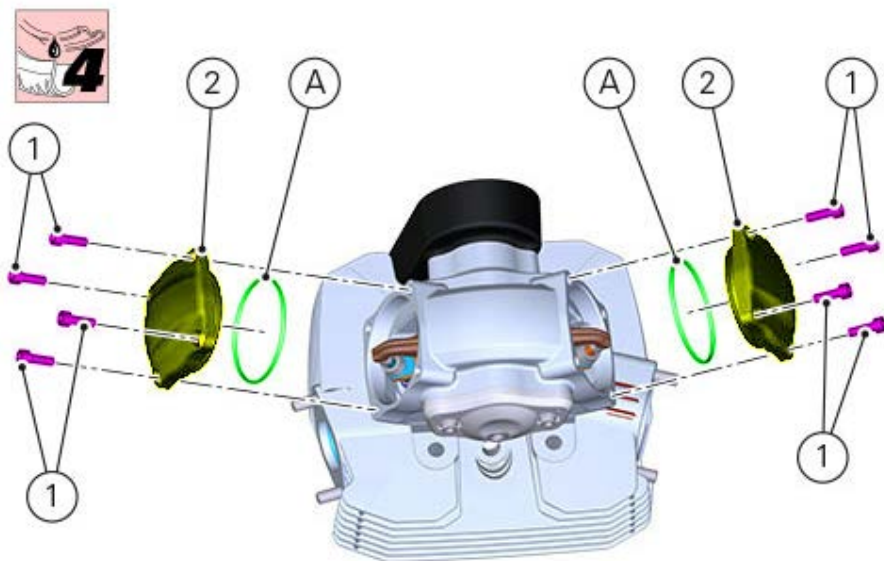

Check of the camshafts and supports

Check the cam contact surfaces for scratches, grooves, steps and waving. Worn cams are frequently the cause of poor timing, which leads to loss of engine power. Place the camshaft between two opposite centres and check the run-out using a dial gauge:
- service level: **0.1 mm**.

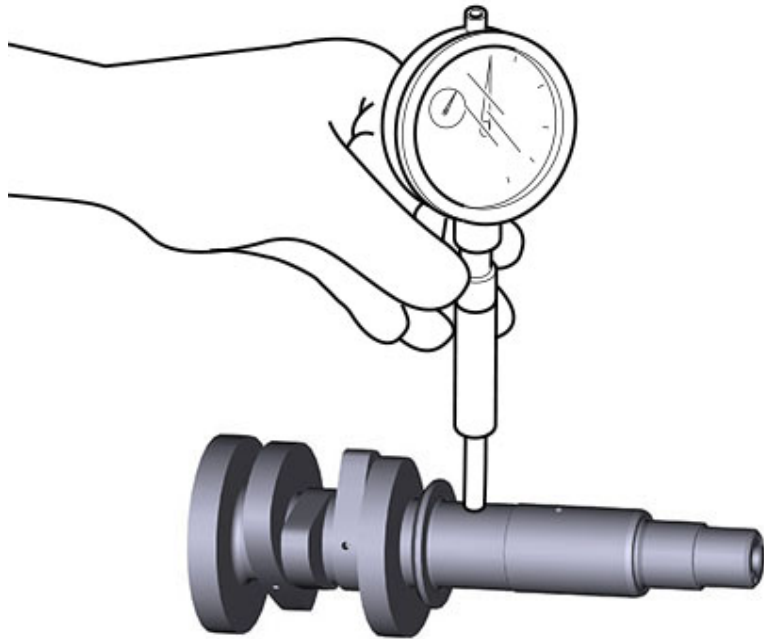

The camshaft has a punched letter:

O = horizontal;

V = vertical.



Oil seal check

Replace the seal upon every engine overhaul.

Install new oil seals keeping them square in their seats using suitable drifts.

After the assembling operations, lubricate the oil seal lip. Pay utmost attention when performing this operation.

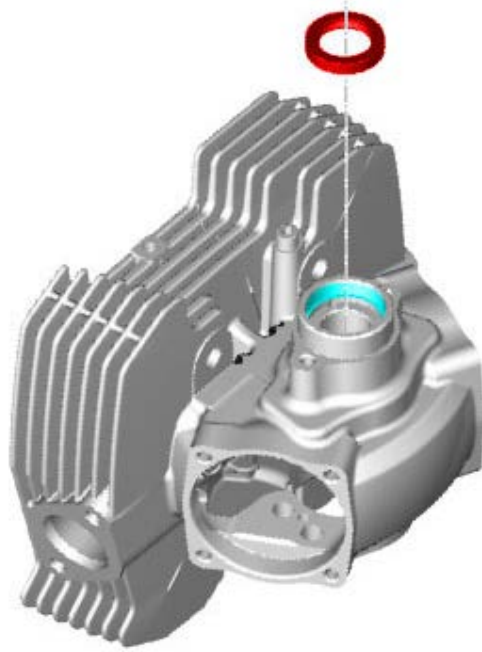

Removing the camshafts

Removing the valve covers

Loosen the screws (1) securing valve covers (2) and remove the covers.

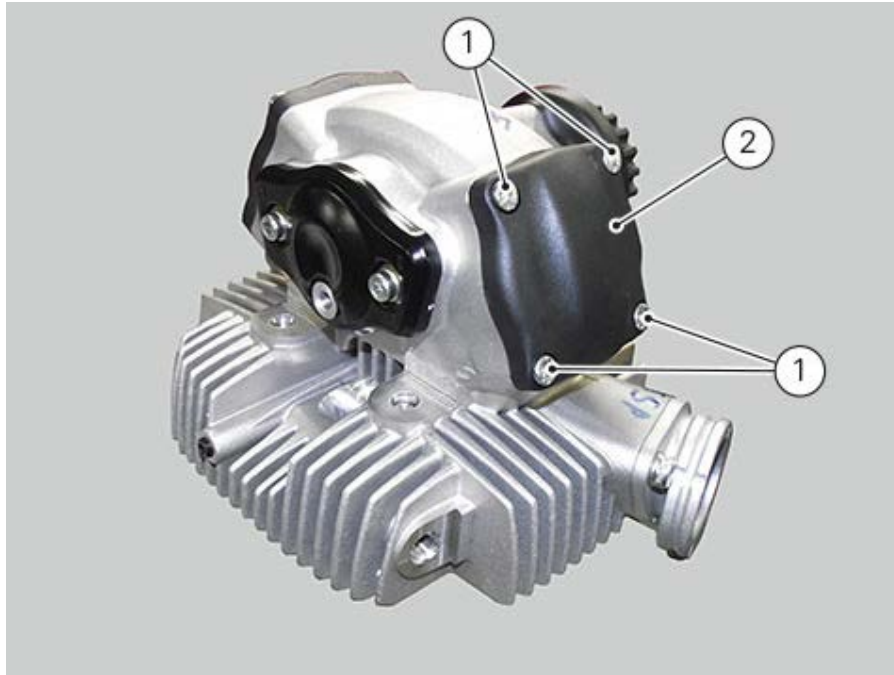

Removing the timing internal cover

Remove the head pulley ([Removing the camshaft pulleys](#))

Loosen screws (3) and remove cover (4).

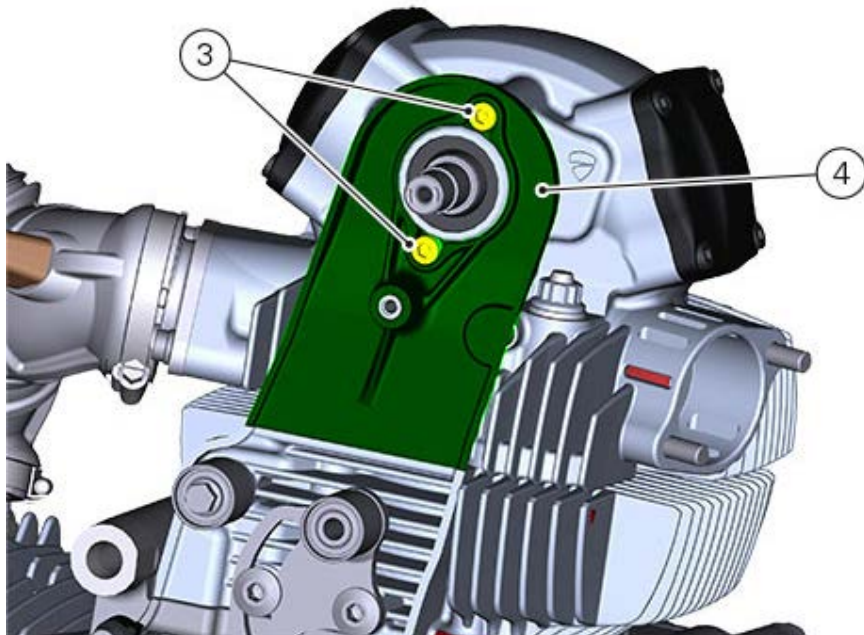

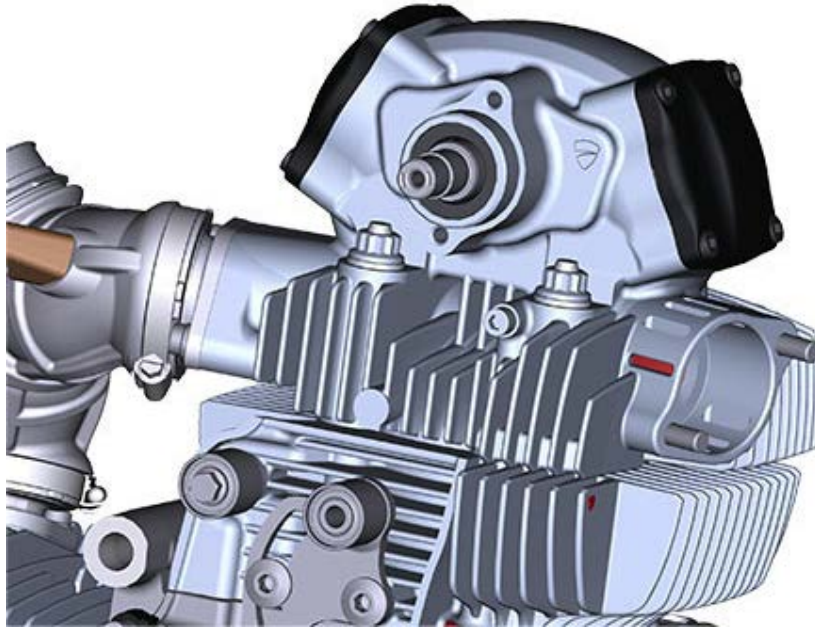

Removing the rocker arm shaft cap

Loosen screws (5) securing cap (6) and remove it.

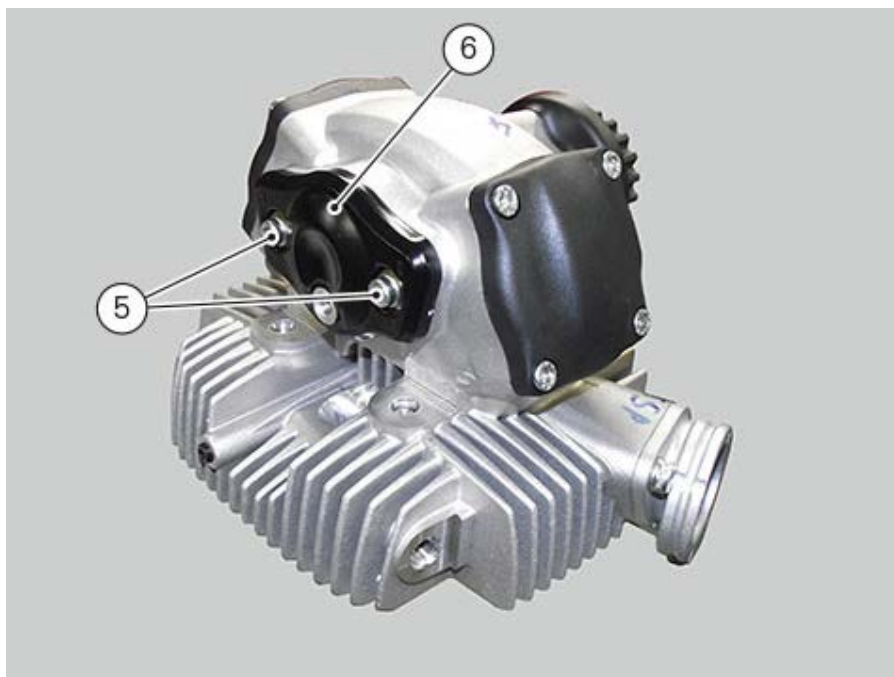

Remove keyway (7) of camshaft (8).

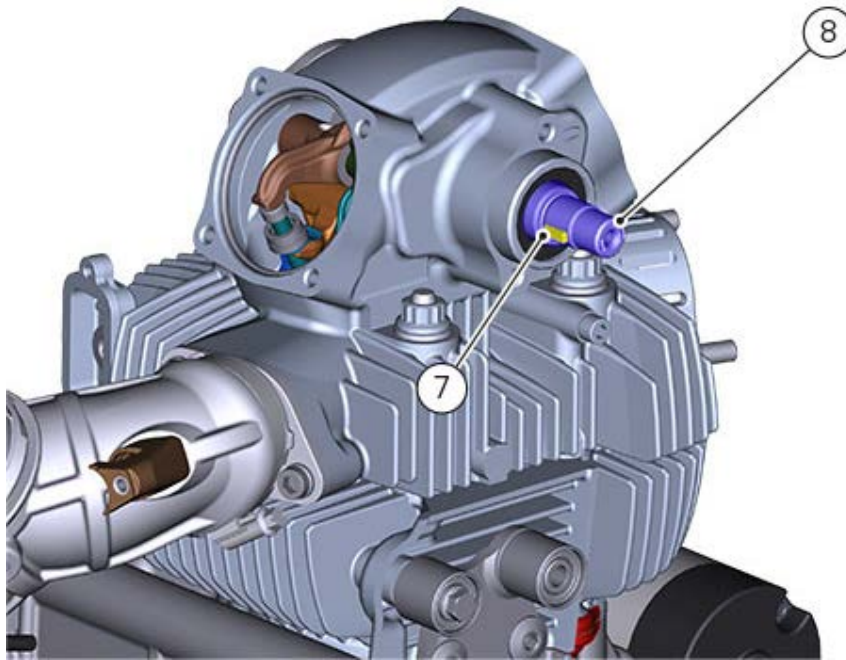

Note

Upon disassembly, to avoid damaging the components, rotate the camshaft until the cams are in a position that does not interfere with the rocker arms.

To facilitate the operations with installed rocker arms, remove spring (9) of the opening rocker arm (10).

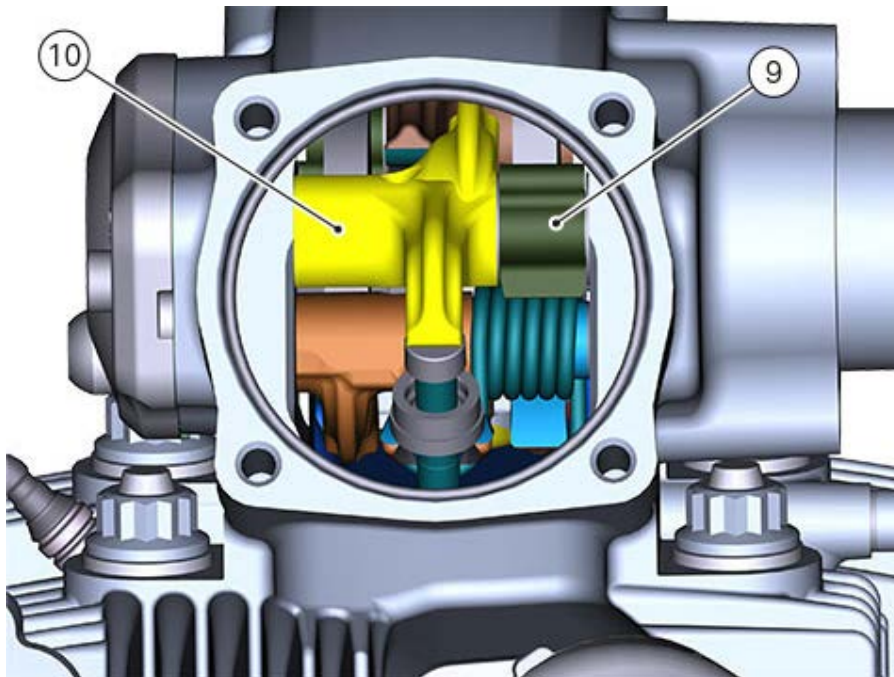

Slide cylinder head camshaft (11) out of its seat.
Remove the snap ring (12) from the cylinder head.

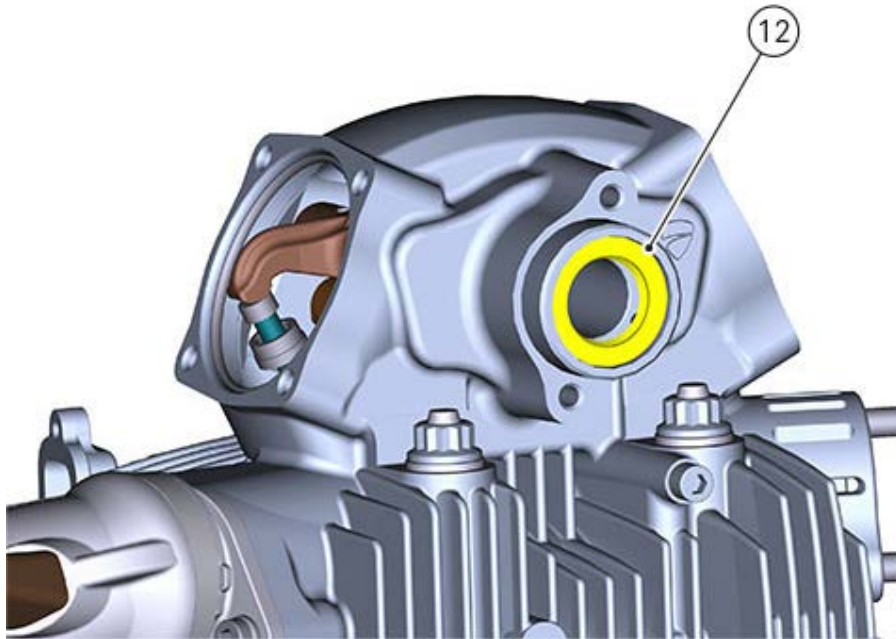
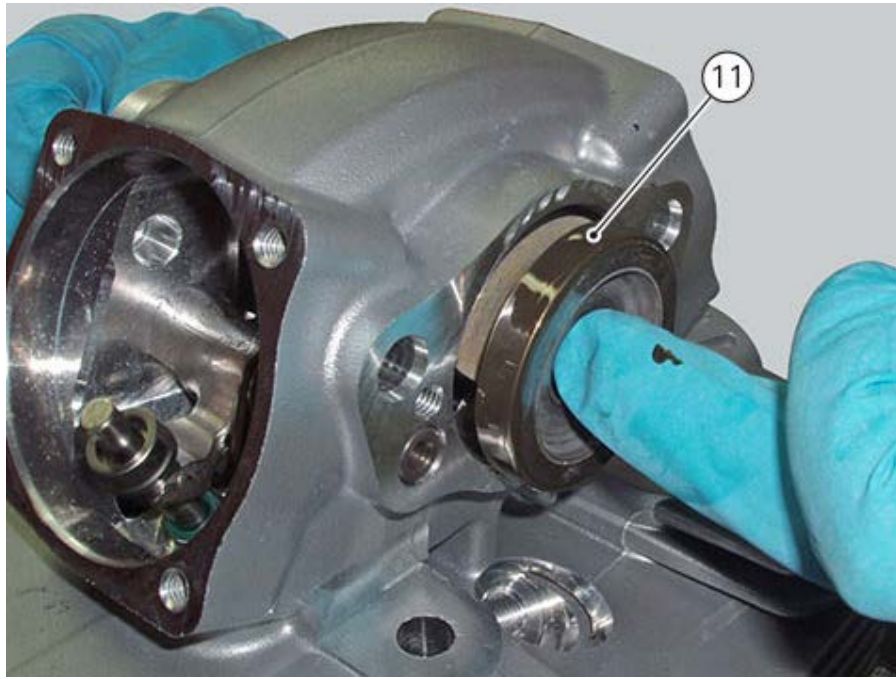

Refitting the cylinder heads

Warning

To prevent oil leaks in the contact area between cylinders and crankcase, each time the head is removed, cylinder and piston must be removed as well to clean the mating surfaces of crankcase and cylinder and restore the worn gaskets and O-rings and apply again sealing compound.

Before fitting the complete heads replace the head gasket (3) and check that there are the reference pins (C) and bushings (D).

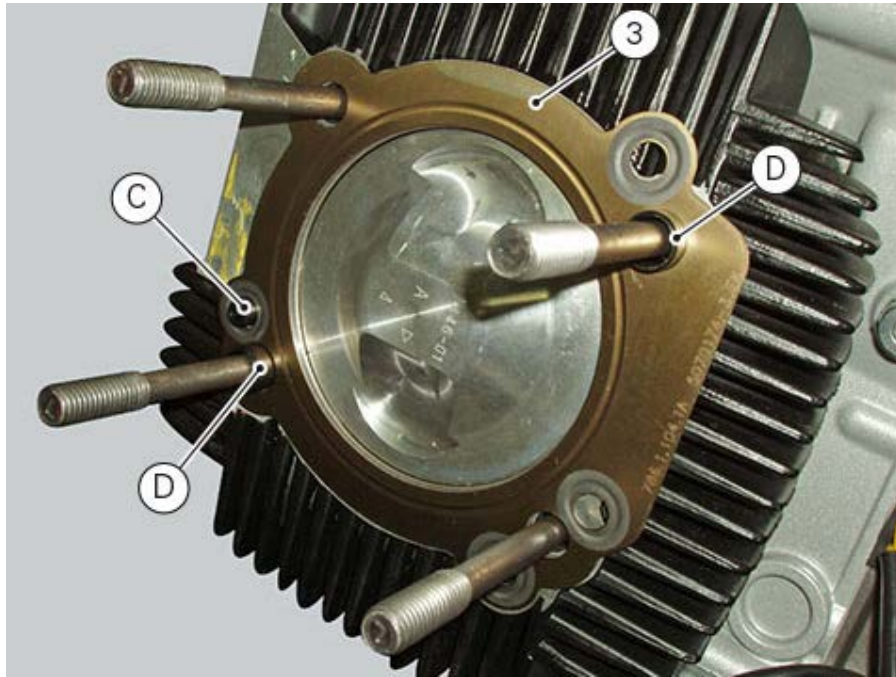

Fit the complete head on the casing stud bolts and bring it fully home on the cylinder.

Fit the special washers (2) in the stud bolts with the sharp edge facing the head and the flat side facing inside.

Grease the nut (1) underneath and the stud bolt thread with specified grease.

Use tool no. **88713.2676** with a torque wrench to tighten the retaining nuts, following a cross pattern, first to a snug torque of 15 Nm (Min. 13 Nm - Max. 17 Nm), then to a pre-load torque of 30 Nm (Min. 28 Nm - Max. 32 Nm), then to a final tightening torque of 48 Nm (Min. 46 Nm - Max. 50 Nm)

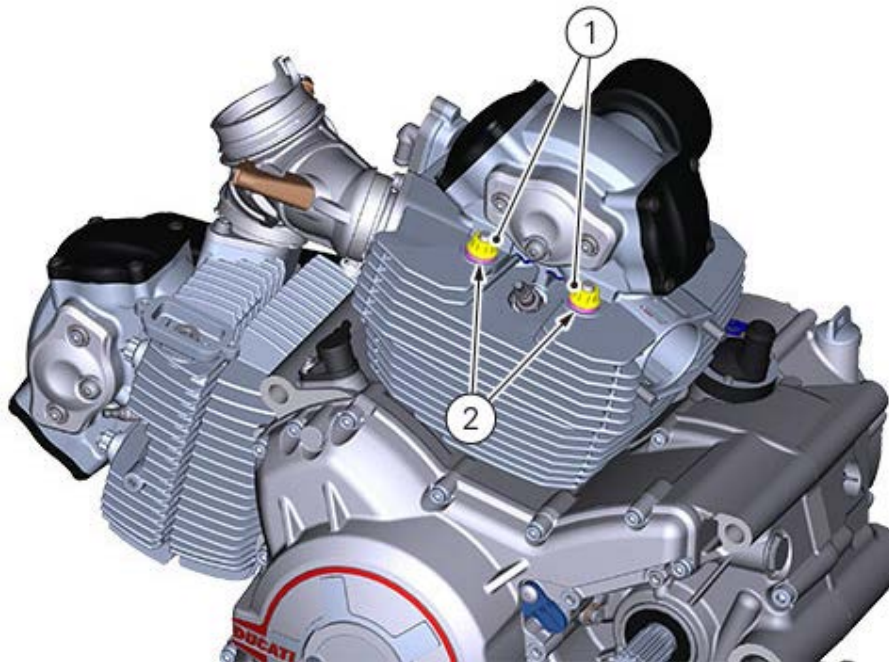

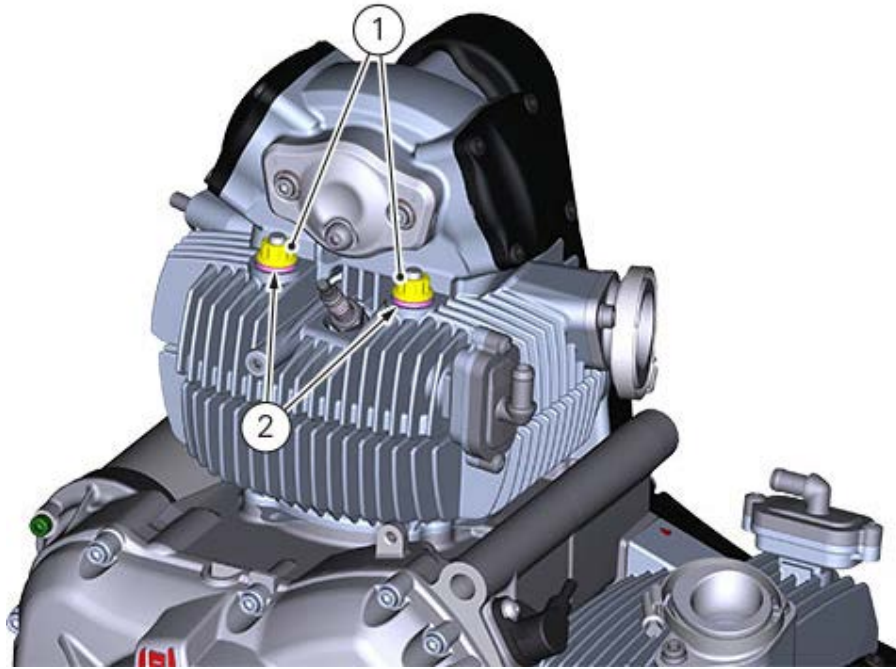

Important

Failure to follow the described procedure may cause an abnormal stretch of the stud bolts and serious damages to the engine.

Refit the engine in the frame.

Refitting the valves and rocker arms

To refit them follow the removal reverse procedure, paying attention to the operations that are specifically indicated.

It is extremely important to thoroughly clean all components.

If seal rings (17) of the valve guides have been removed, fit new ones after lubricating them with engine oil and fit them on the side with spring on tool no. **88713.2442**.

Fit the end of the tool into the valve guide and use a hammer to tap the sealing rings (17) home into the valve guides.

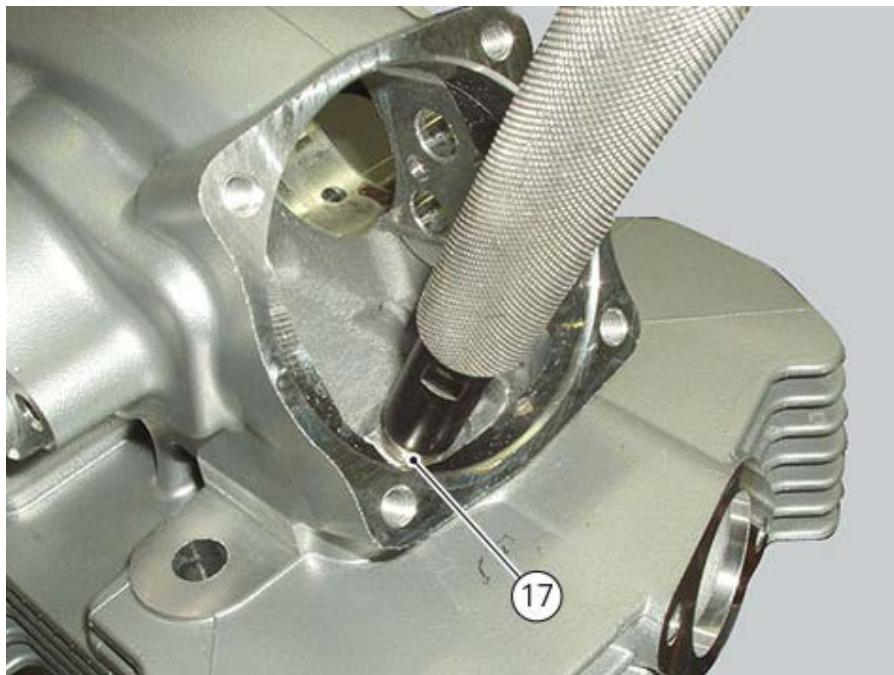
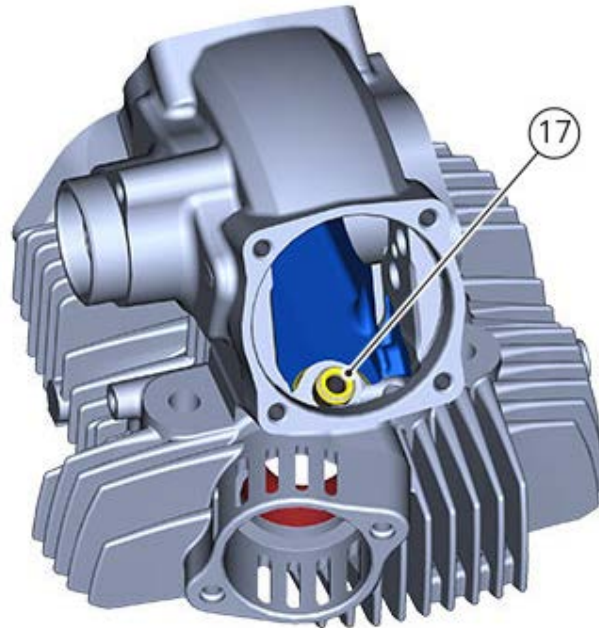

Refitting rocker arms, shims and valves

Closing rocker arm

Fit on tool (A) no. **88713.2783** the closing rocker arm (10) and the relevant spring (15).
Fit the tool-rocker arm-head spring assembly and shaft (14) with a new lubricated seal.

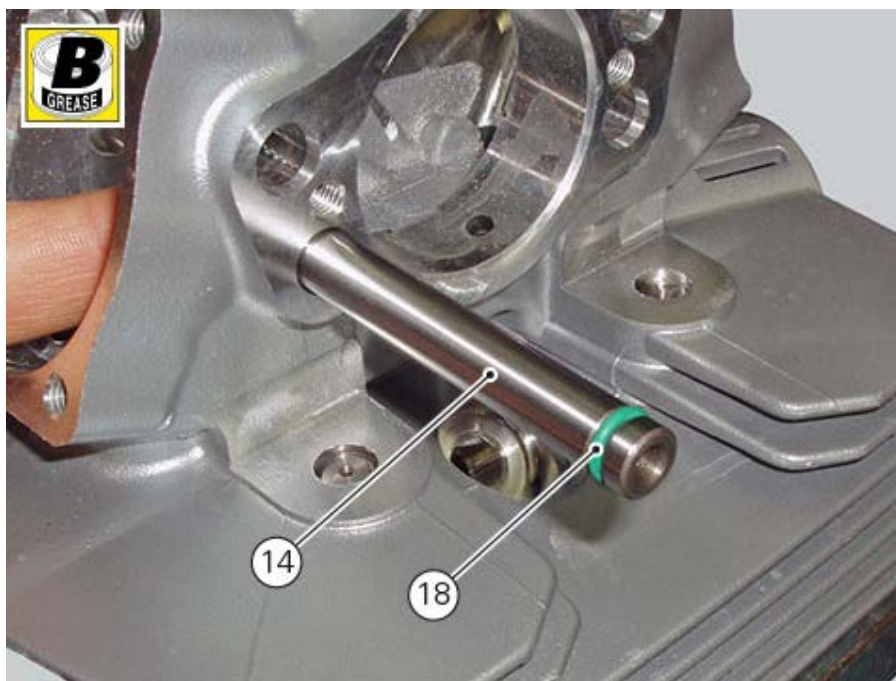
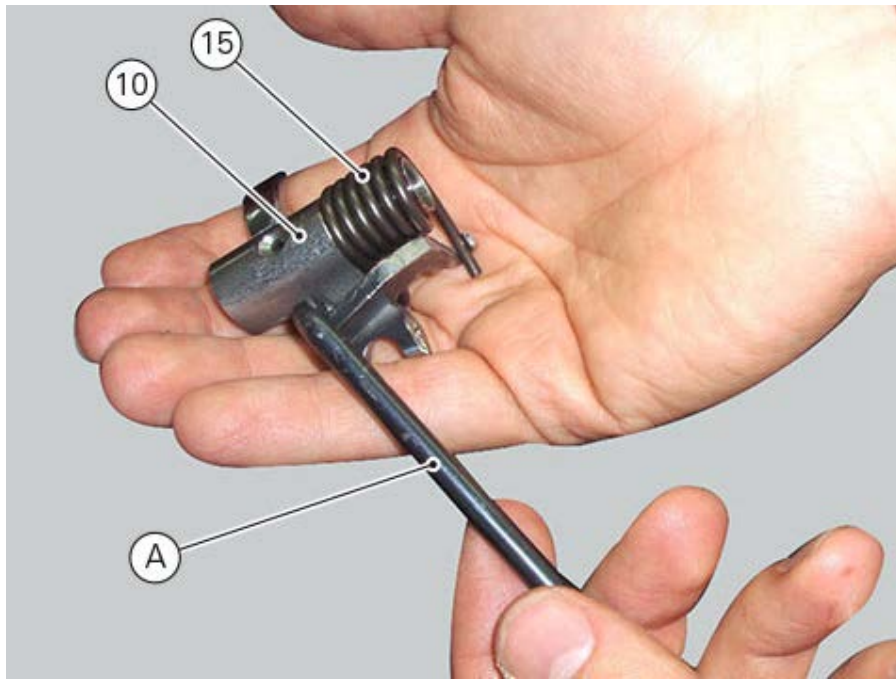

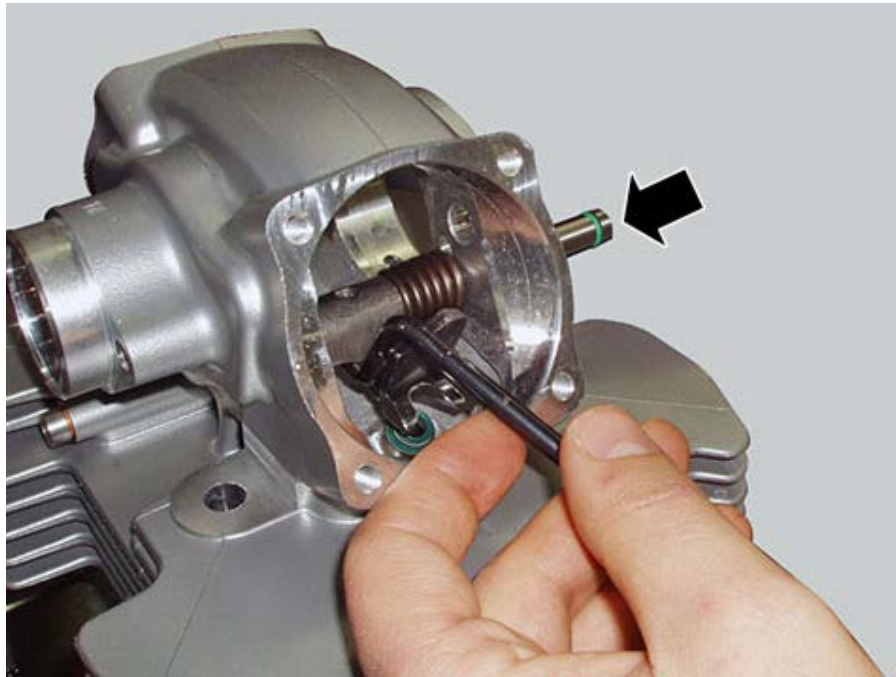

Important

When refitting the rocker arm shafts, make sure that the threaded hole is on the head outer side.

Release spring (15) and remove tool (A) no. **88713.2783**.

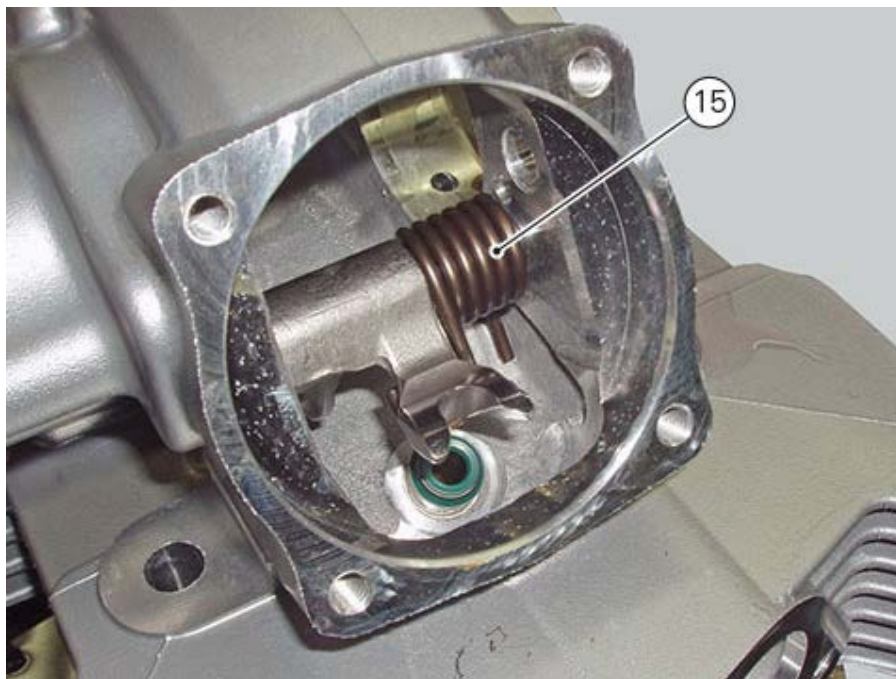

Follow the same procedure on the exhaust side.

Lubricate valves (19) with engine oil and fit them.

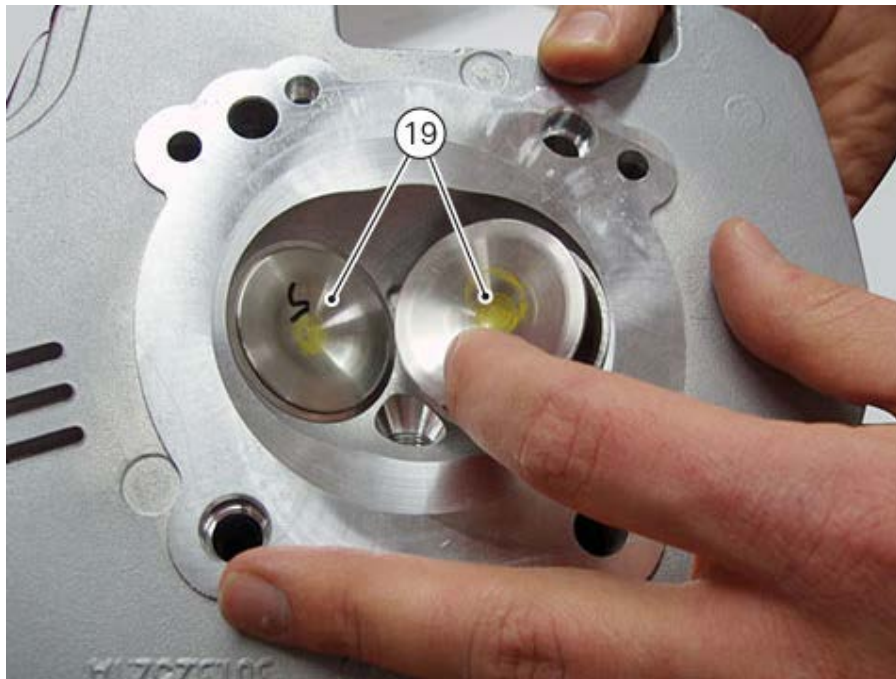

Temporarily fit the camshaft.

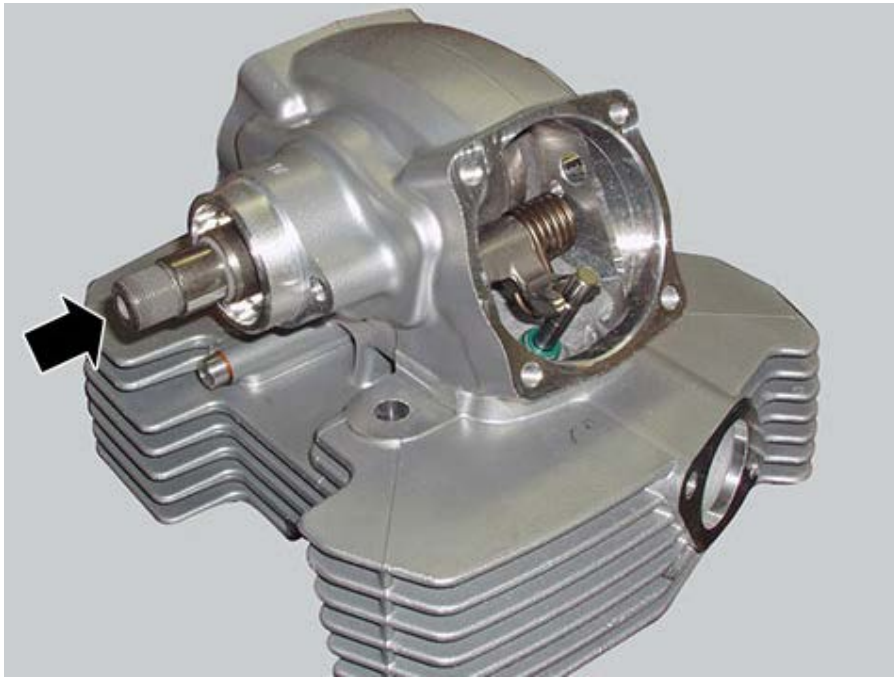

Use a suitable tool to block the closing rocker arm (10) in the position with valve open.

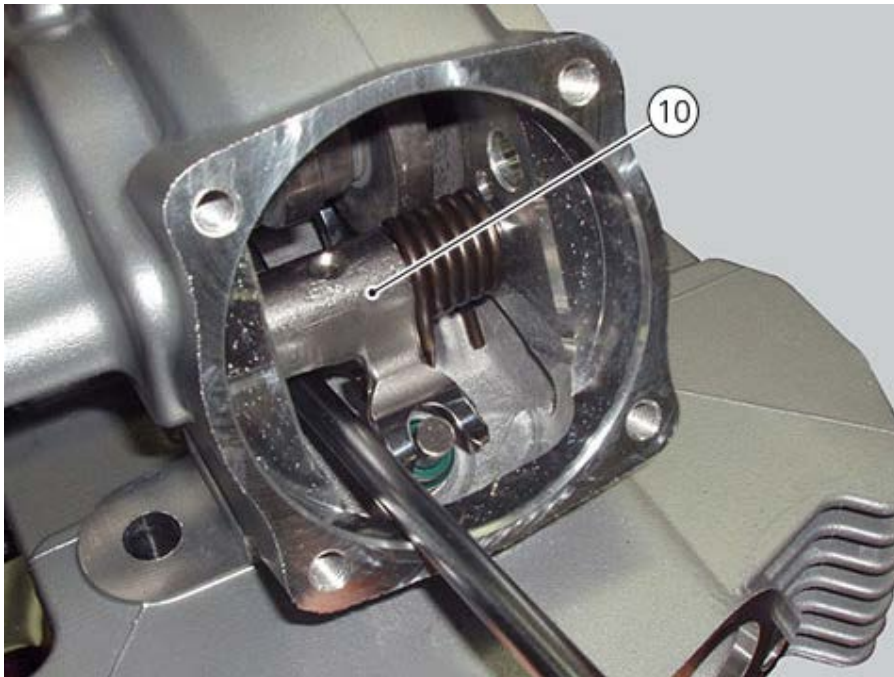

Fit the closing shim (11) with the bigger diameter side facing down in the valve stem (12).

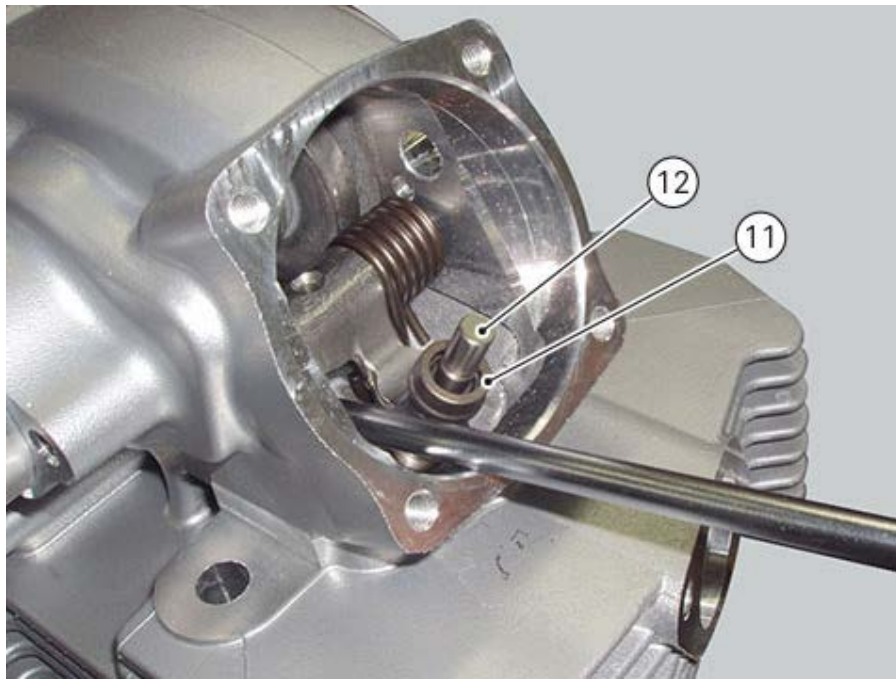

Position the two split rings (13) on the valve stem.
Remove the screwdriver and position the closing rocker arm (10) in its rest position.

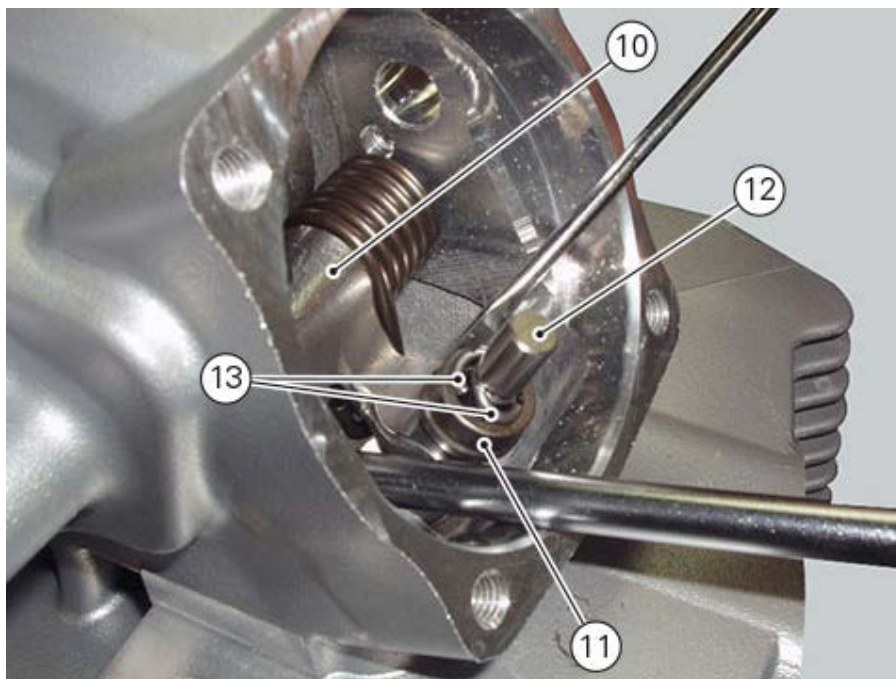

Use a suitable tool to compress the spring as much as possible while holding valve, shim and split rings in the valve closed position.
Release the closing rocker arm (10) with a quick movement, so that the split rings seat in the shim.

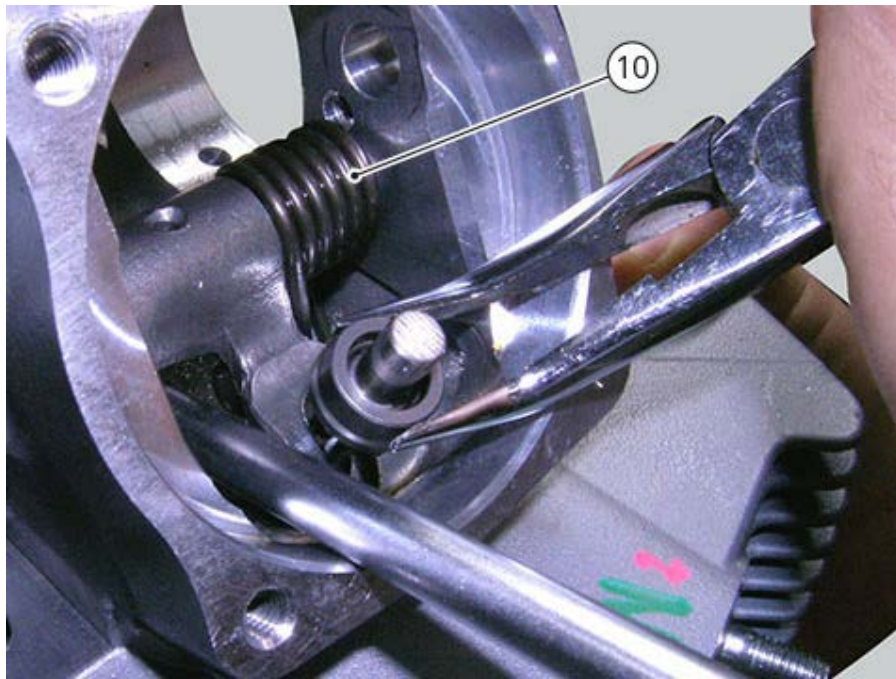

With the valve in rest position and by counter-holding the return spring, push on the rocker arm and check that the clearance between the rocker arm sliding shoe and the closing shim is the specified one. If this is not the case, adjust the valve clearance.

Once the specified clearance is reached, remove the temporarily-fitted camshaft, lubricate it with oil and reposition it on the cylinder head.

Opening rocker arm

Insert rocker arm shaft (7) with the threaded hole on the head external hole: seal (20) must be replaced upon every reassembly operation and the new one must be duly lubricated.

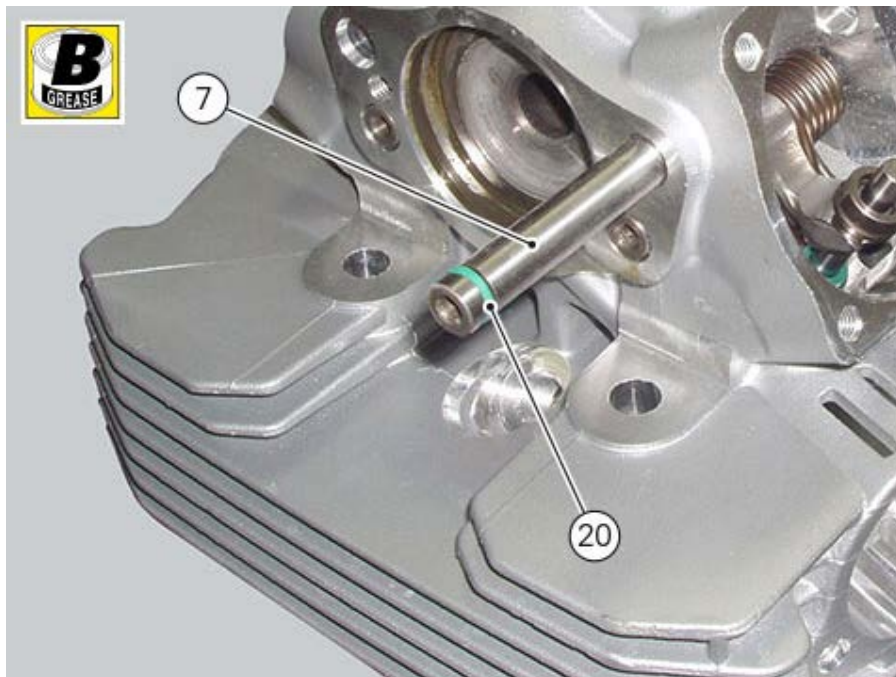

Position the opening rocker arm (5) and two shims (8) on shaft (7).

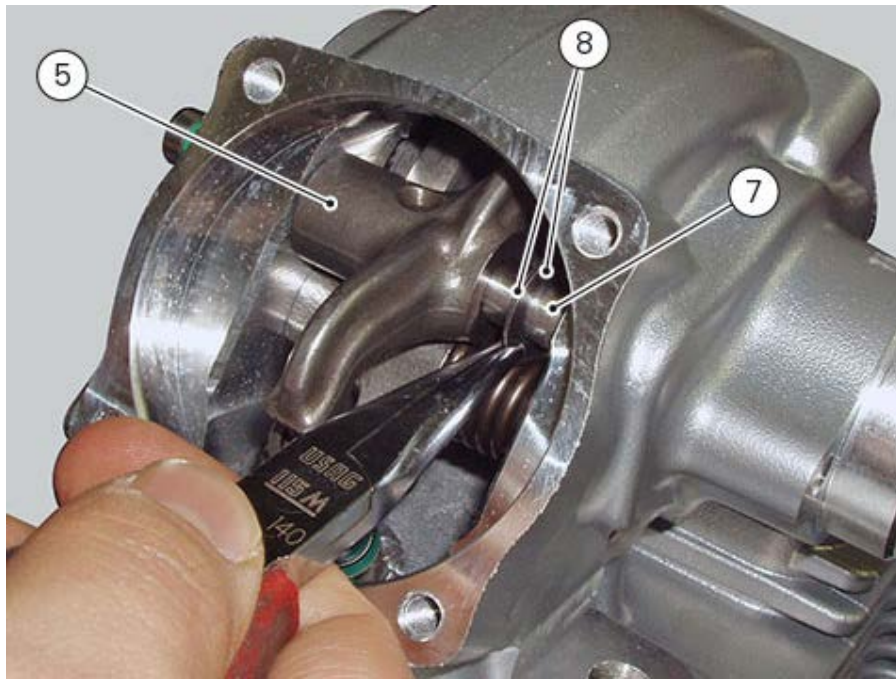

Refit the timing side cap ([Refitting the camshafts](#)).

Refit the timing pulleys ([Refitting the cylinder head pulleys](#)).

Position the valve opening shim.

With the valve in rest position, check that the clearance between rocker arm and the relevant adjuster is the specified one.

If this is not the case, adjust the valve clearance.

Fit the lateral spring (4) on shaft (7) of the opening rocker arm (5) between the two spacers (8).

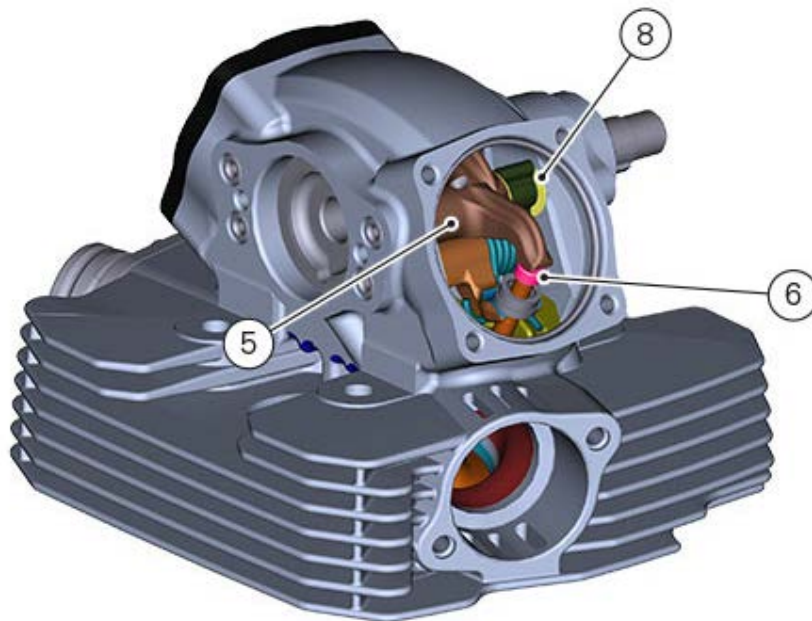

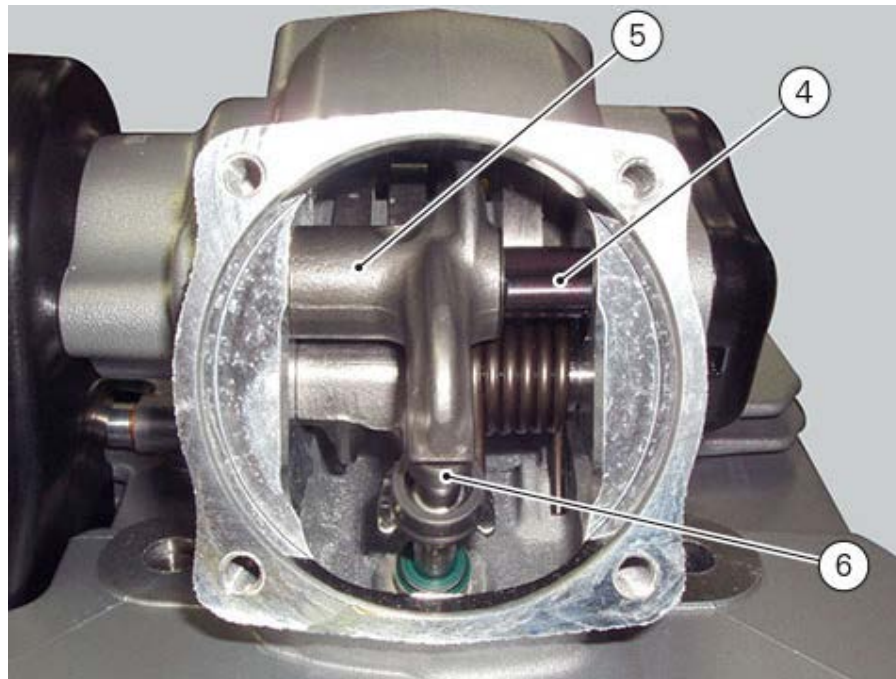
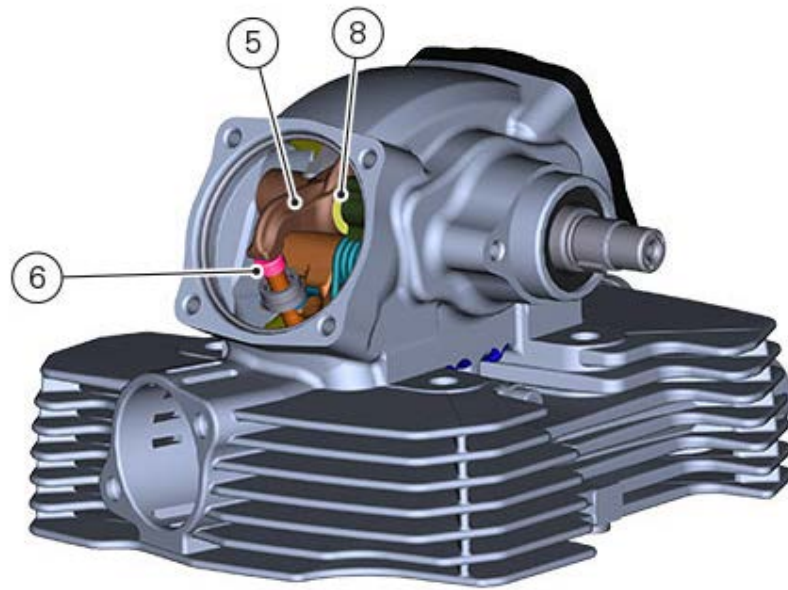

Refit the caps, the camshafts and the valve covers ([Refitting the camshafts](#)).

Overhauling the cylinder head components

Overhauling the heads

Remove any carbon deposits from the combustion chamber and its ducts.
Check for cracking and inspect the sealing surfaces for scoring, steps or other damage.

Make sure the coupling surface with the cylinder must be perfectly flat. If this is not the case, spread diamond lapping paste ($6 \div 12$ micron thickness) on a reference surface and slide the cylinder head with circular movements on the surface until a flat surface is obtained.

Checking the valves

Check that the stem and the valve seat contact surface are in good condition.
There must be no pitting, cracks, deformations or signs of wear.



Warning

The valves cannot be ground.

Perform the following checks: measure the diameter of the valve stem at various points along the section that runs in the valve guide.



Check the valve stem for buckling. Place the valve on a "V" reference block, set a dial gauge perpendicular to head and measure concentricity of valve face at 45° :
- Service level: 0.03 mm

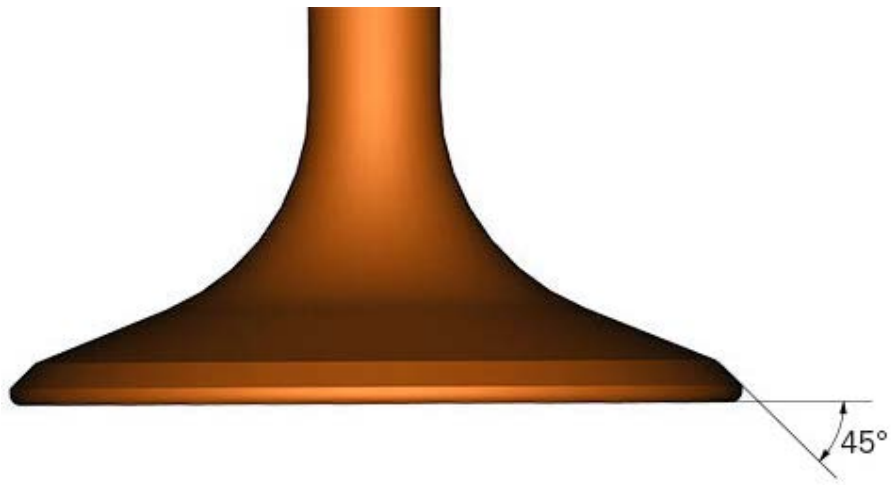

Checking the valve seats

Visually check the seats: they do not have to be excessively recessed or feature pitting or cracks. In case the seat is slightly damaged, grind it using suitable 45° grinders and then lap the valves and check for any leakage. If the valve seats are excessively damaged, fit oversized seats. Spare seats are available with 0.03 and 0.06 mm oversized outside diameters.

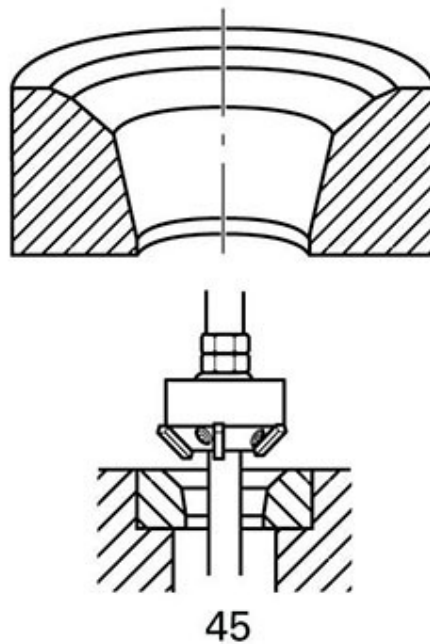

Valve guide

Check the internal surface of the valve guides: there should be no signs of deformation or cracking.

Thoroughly check the dimensions of the valve guide.
 Measure the inside diameter with a suitable gauge.
 Measure the diameter at different positions of the valve guide.

Check the diameter of head housings and choose the oversized valve seat that will give an interference fit of **0.11 ÷ 0.16** mm.

The valve seats are available as spare parts with outer diameter oversized by **0.03** and **0.06** mm.

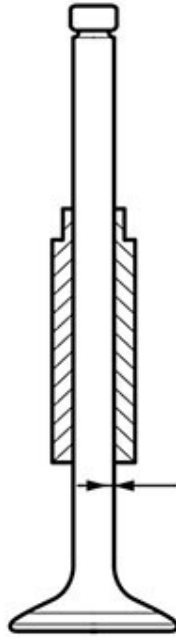

Heat the cylinder head gradually and evenly to 200 °C and chill the valve seats in dry ice. Drive the seats keeping perfectly square in their housing using the suitable drift.



Leave them cool down and grind them, the union of the ducts with the new seats and lap the valves.

Coupling valve seat and valve

Use Prussian blue or a mixture of minium and oil to check that the contact surface (A) between valve and seat is **1.0 ÷ 1.5** mm.

Maximum allowed limit: **2.0** mm.

Grind the seat if the dimension measured is greater than the above limit.

Fill the fuel intake and discharge ducts to check for any leakage; in case of leakage, check that there are no burrs on the concerned seal surface.

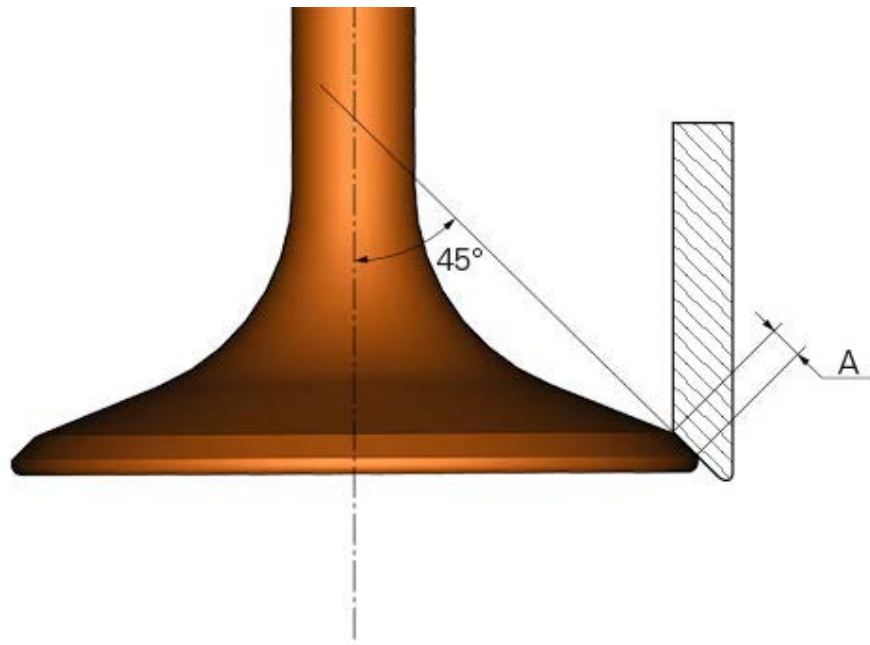

Checking the valve – valve guide coupling

Clearance upon fitting: **0.03 ÷ 0.06** mm.
 Maximum allowed wear limit: **0.08** mm.

Replacing the valve guide

To replace the guide valve (16) it is necessary to perform the following operations.

Heat up the cylinder head gradually and evenly in an oven up to **200 °C**.

Slide out the valve guide using a suitable drift.

Leave it cool and check the seat conditions and dimensions.

Choose a suitable valve guide to obtain an interference fit in the cylinder head of **0.022 ÷ 0.051** mm; they are available as spare parts with outer diameter oversized by **0.03**, **0.06** and **0.09** mm provided with stop ring.

Heat up the cylinder head again and chill the new valve guide in dry ice.

Install the valve guides after lubricating their seat, bring the stop ring fully home in the cylinder head using the drift suitable for its removal.

Leave the cylinder head cool and bore the internal hole.

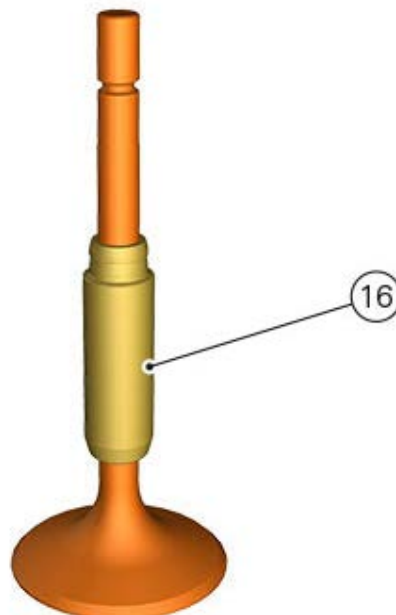

Overhauling the rocker arms

Check for signs of wear, grooves or chrome flaking off.

Check the conditions and the diameter of rocker arm bore and shaft:

- rocker arm internal hole nominal diameter: **10.040 ÷ 10.062** mm;

- shaft nominal diameter: **10 ÷ 0.005** mm.

Check that the work surfaces of the adjusters and the valve return shim caps are perfectly flat and do not feature wear signs.



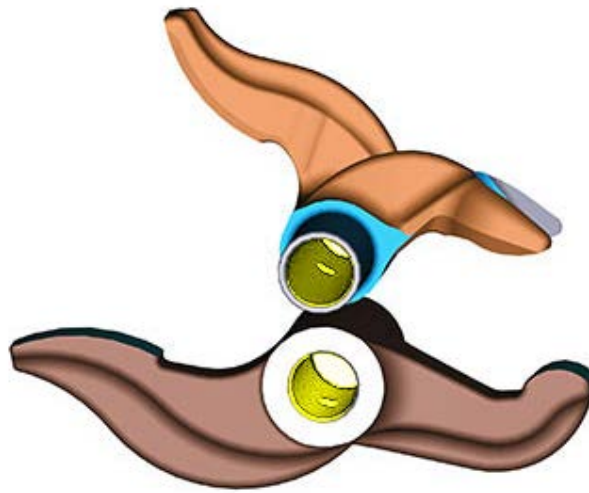

Rocker arm-rocker arm shaft coupling

The clearance upon fitting must be **0.03÷0.06** mm.

Maximum allowed wear limit: **0.08** mm.

The rocker arms must be slightly forced on the cylinder head.

If the clearance is excessive, fit the shafts oversized by **0.02** mm.

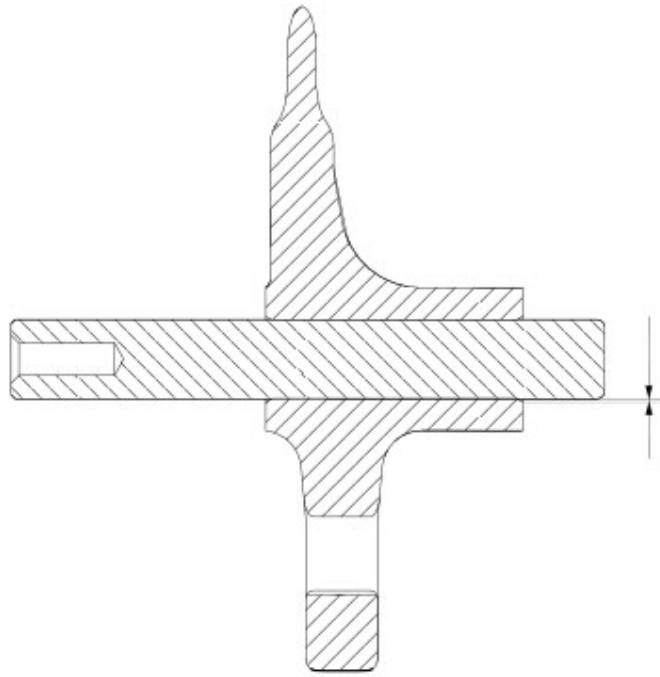

Checking the rocker arm springs

Thoroughly check the springs (15) of the closing rocker arms (10). No cracks, deformations or failure must be present.

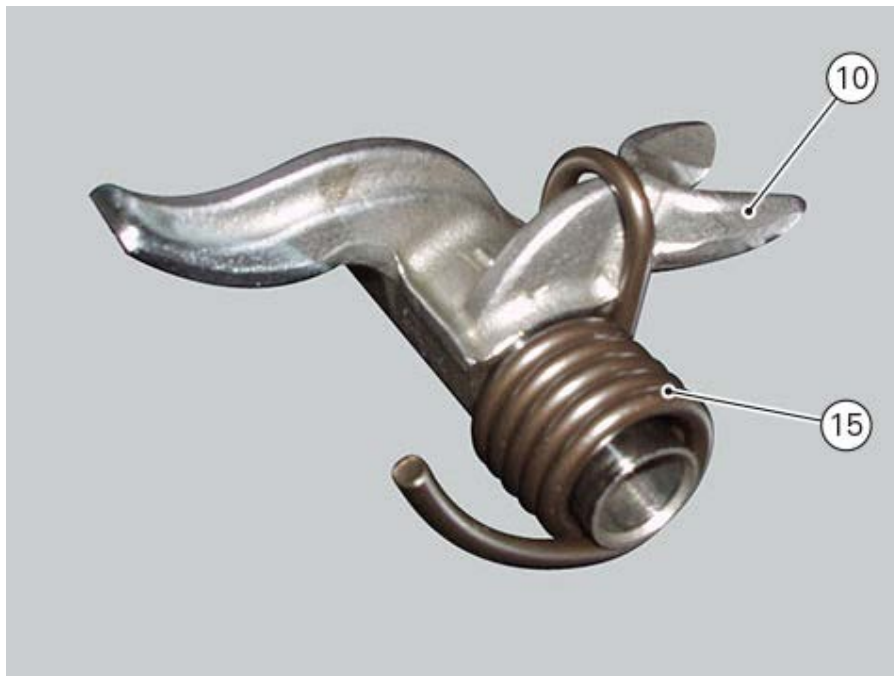

Removing the valves and rocker arms

Remove the valve covers, the camshafts and the relevant caps ([Removing the camshafts](#)).

Slide out spring (4) of the opening rocker arm (5).
Move rocker arm (5) to free the opening shim (6).

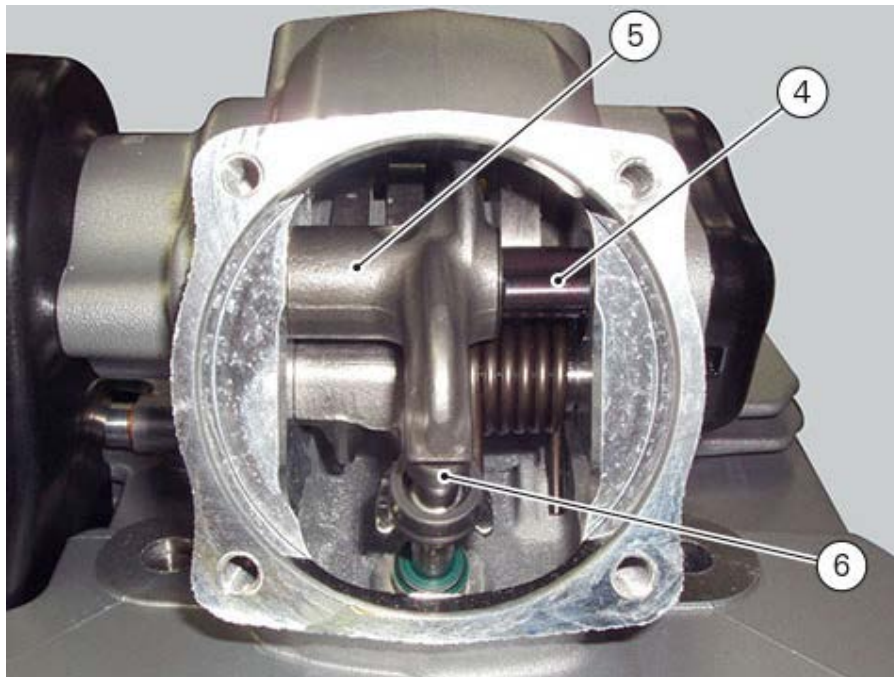

Screw tool no. **88713.2837** on the threaded end of the opening rocker arm shaft (7).
Slide out rocker arm shaft (7) and recover opening rocker arm (5) and the two shims (8) and (9).

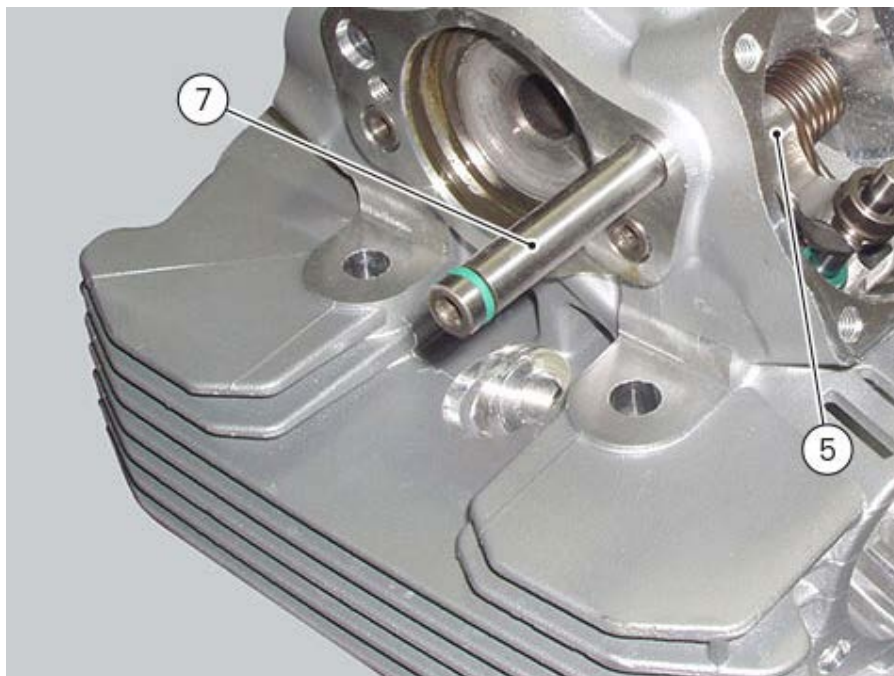

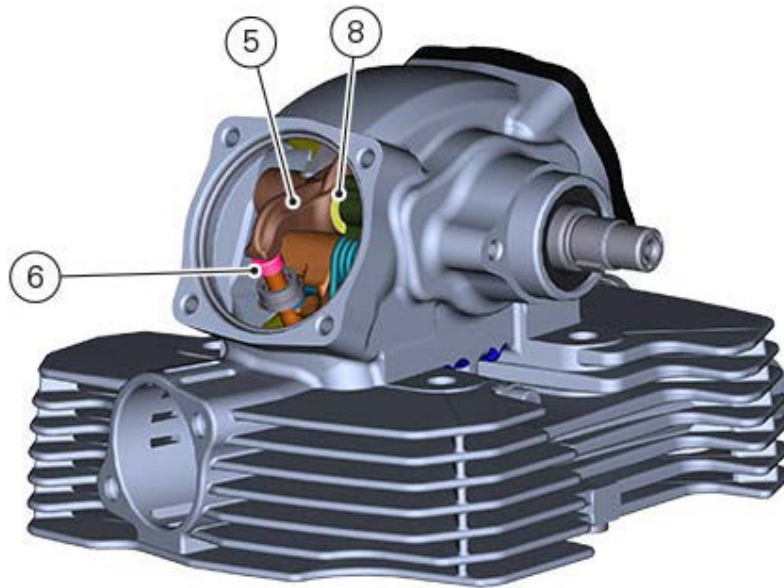
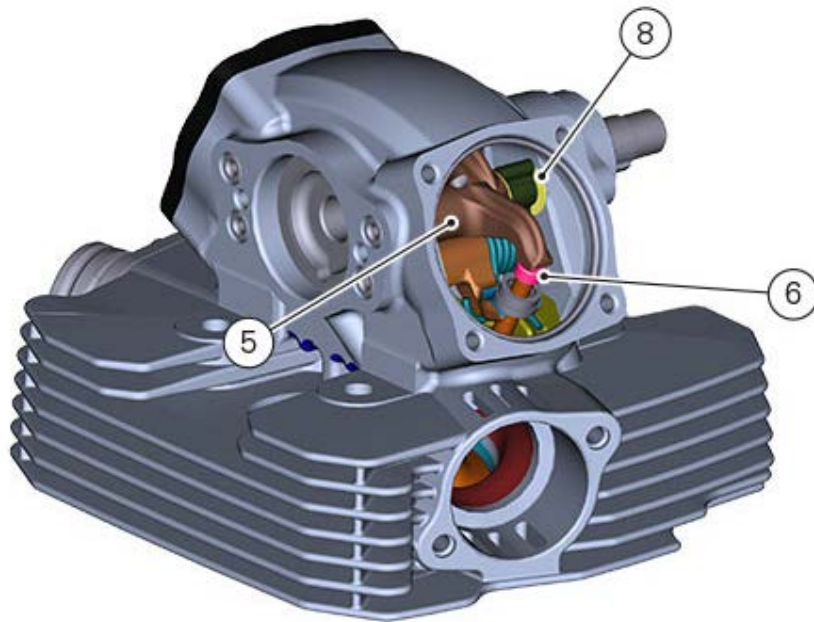

Use a suitable tool to block the closing rocker arm (10) in the position with valve open.
Slide the valve closing shim (11) on the intake valve stem (12) to allow the removal of the two split rings (13) that retain the valve.
Use small-tip pliers or a magnet screwdriver to remove the split rings (13) from the valve stem.

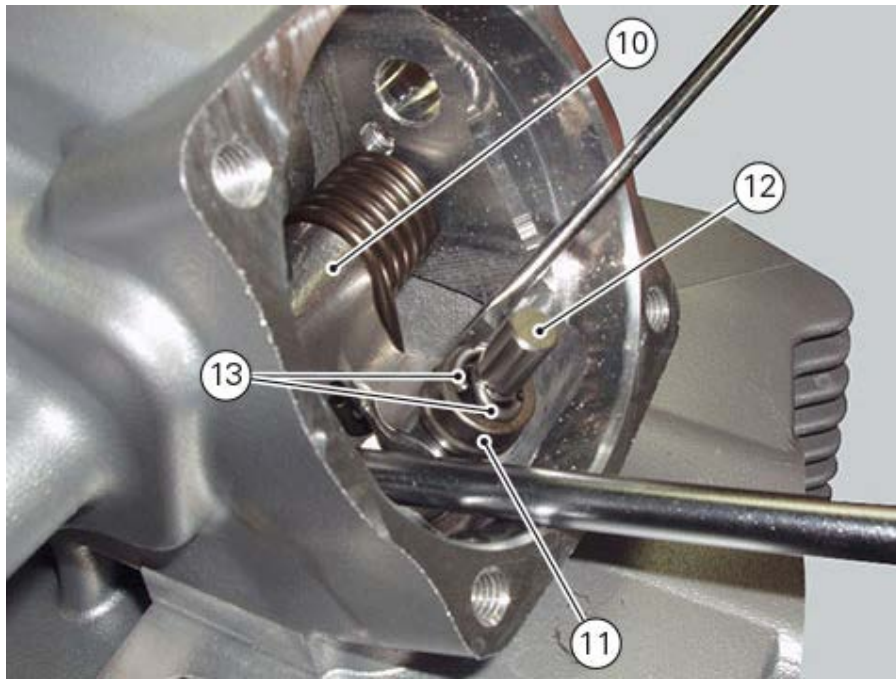

Slide out valve closing shim (11) from the valve (12).
Withdraw valve (12) from the lower side of the cylinder head.

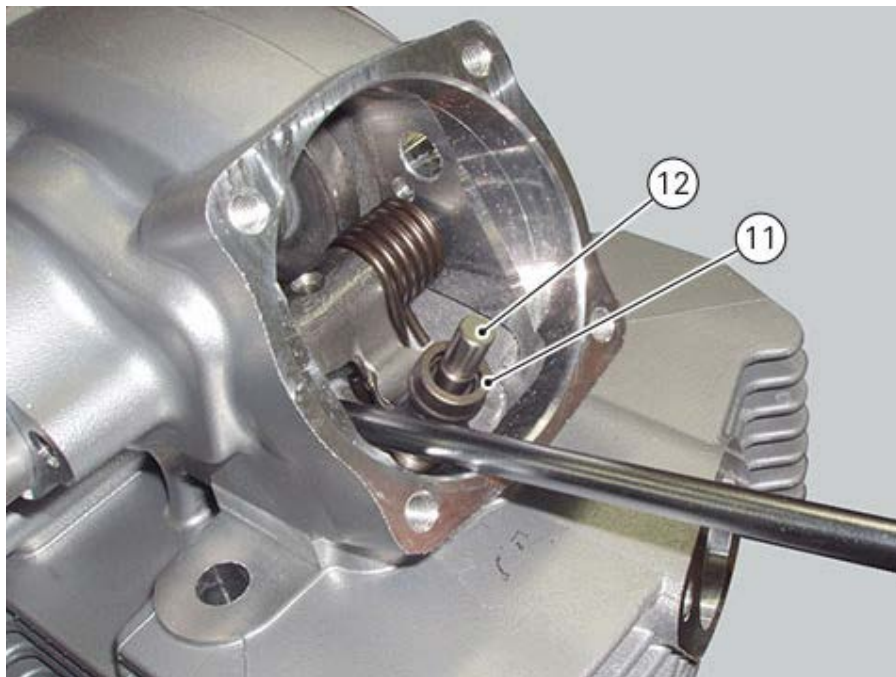

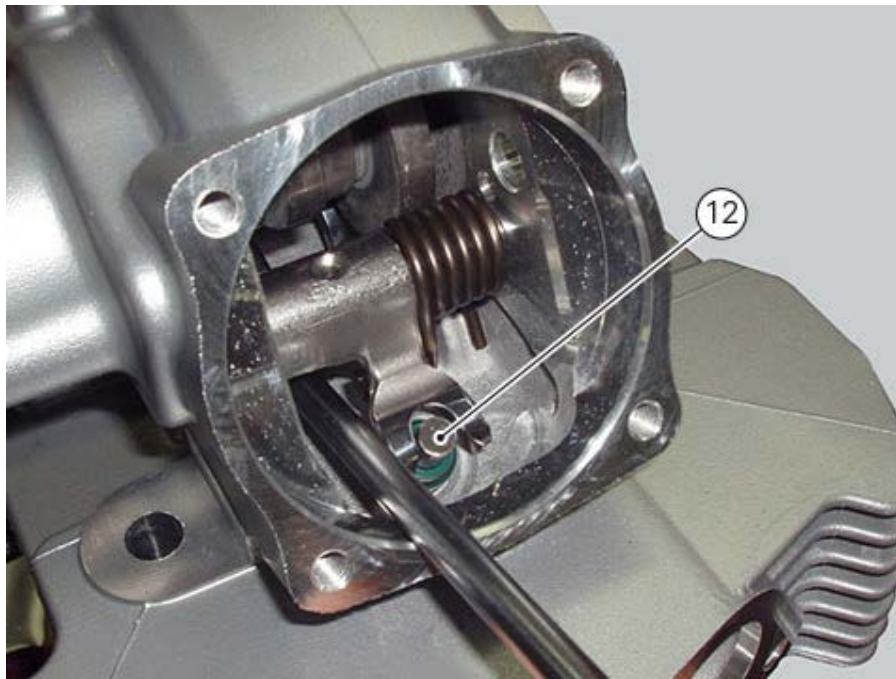

Repeat the same operations for the exhaust side.
Slide out closing rocker arm shaft (14) using tool no. **88713.2837**.
Slide out rocker arm (10) and spring (15).

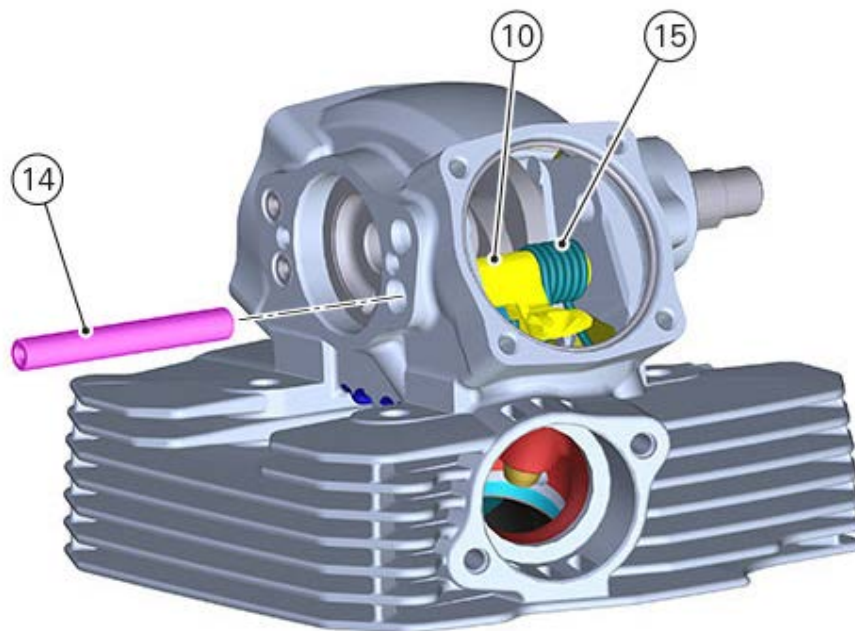

Removing the cylinder heads

Using tool no. **88713.2676**, undo nuts (1) on the cylinder head stud bolts.
Remove nuts (1) and collect the special washers (2) located between nut and head.

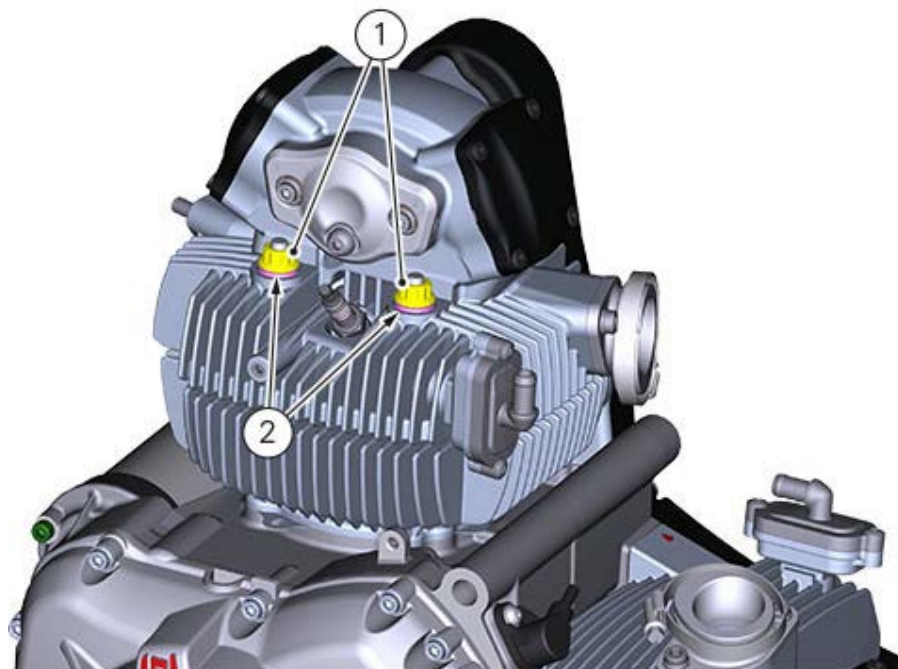
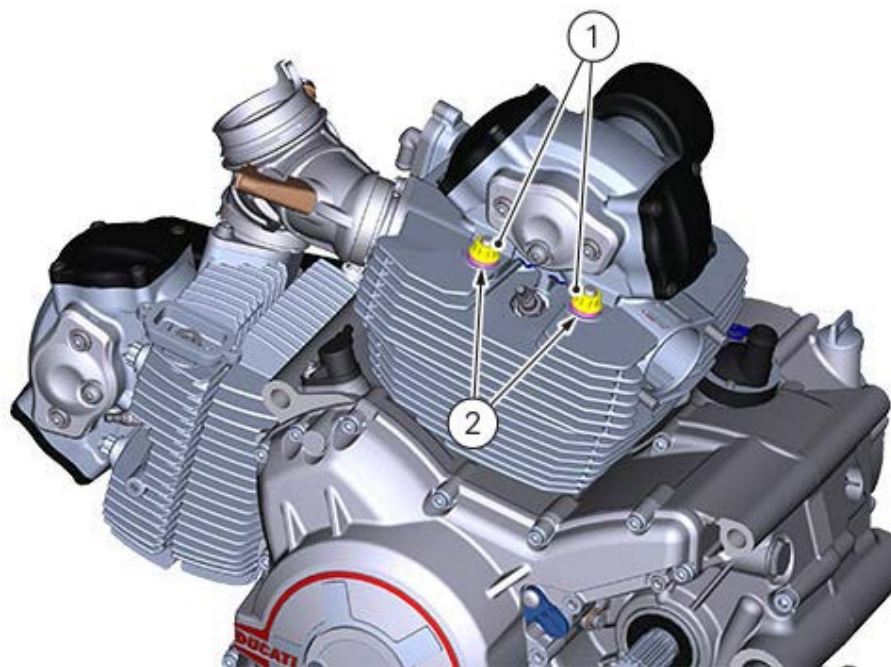

Remove the complete head from the engine by sliding it out of the stud bolts.
Remove the cylinder head gaskets (3).



Refitting the cylinder/piston assembly

If new parts are used, it is necessary to match cylinders and pistons of the same selection. The letter that indicates the cylinder selection is punched on its upper side, in the cylinder-head coupling surface; the letter that indicates the piston selection is punched on its crown, between the two valve recesses.



If the pistons have been separated from their cylinders, before reassembling these components, position the piston ring gaps at 120° from one another (the markings must always face the piston crown). Using a universal tool, gently insert the piston in the cylinder (lubricate the cylinder inner side with engine oil before inserting the piston).



Remove any deposits and degrease the contact surfaces of the crankcase half and the cylinders. Check that pin (1) is installed on the engine block.

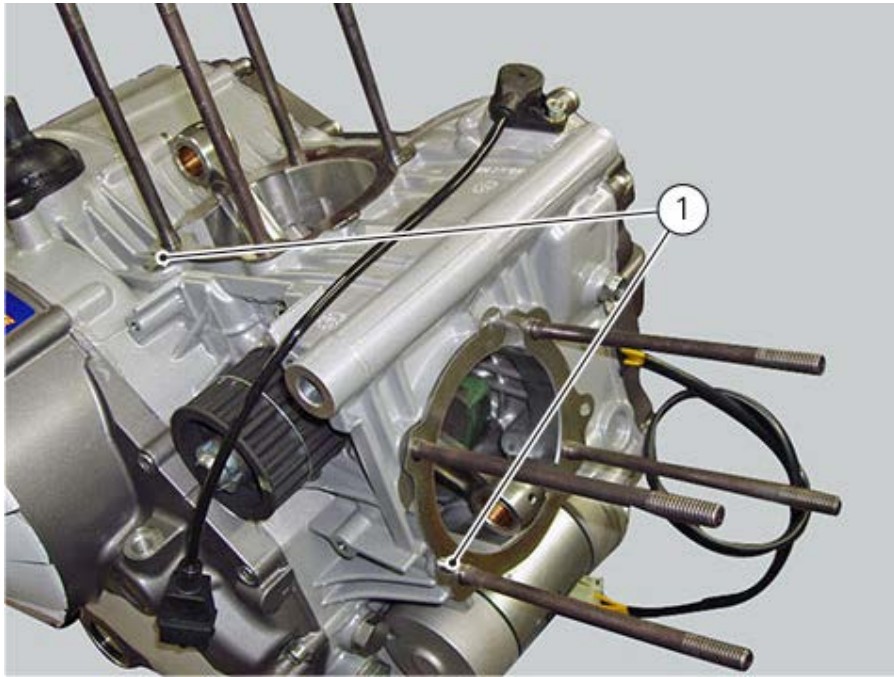

Apply a layer of sealing compound on the gasket (8) contact surface, as required for the vertical cylinder (V) and the horizontal cylinder (O).

The sides touching gasket (6) are:

Side touching the vertical cylinder.

Side touching the casing near the vertical cylinder.

Side touching the horizontal cylinder.

Side touching the casing near the horizontal cylinder.

Position gasket (8) on the casing with the "TOP" wiring facing up.



Overhauling the cylinder/piston components

Overhauling the cylinder

Check that the walls of the cylinder are perfectly smooth. Measure the cylinder diameter at three different heights and in two directions at 90° between them to obtain the coupling, taper and ovality value.



In the event of damage or excessive wear the cylinder must be replaced as it has a silicon carbide coating (which provides the cylinder walls with excellent anti-friction and anti-wear properties) and therefore cannot be ground.

The cylinders are marked with a letter (stamped in a specific area on the cylinder side) indicating their size class.

Always match cylinders with pistons from the same size class.





Overhauling the piston



Clean the piston crown and piston ring grooves, removing any carbon deposits.
Visually inspect the piston and check its dimensions carefully: there must be no signs of scuffing, scoring, cracks, or other damage.
Check the piston diameter.



The pistons must always be replaced as a pair.

Piston - cylinder coupling

The pistons are marked with a letter (punched into the piston crown) that indicates the size class to which they belong.

Always match cylinders with pistons from the same size class.



Overhauling the gudgeon pins

Gudgeon pins must be perfectly smooth without signs of scoring, steps, or blueing due to overheating.

The well-lubricated gudgeon pin must slide smoothly inside the piston without stiffness.

The clearance upon fitting must be **0.002 ÷ 0.008** mm.

The maximum permissible wear limit is **0.035** mm.

If a new gudgeon pin is fitted, you must also change the connecting rod small end bush.

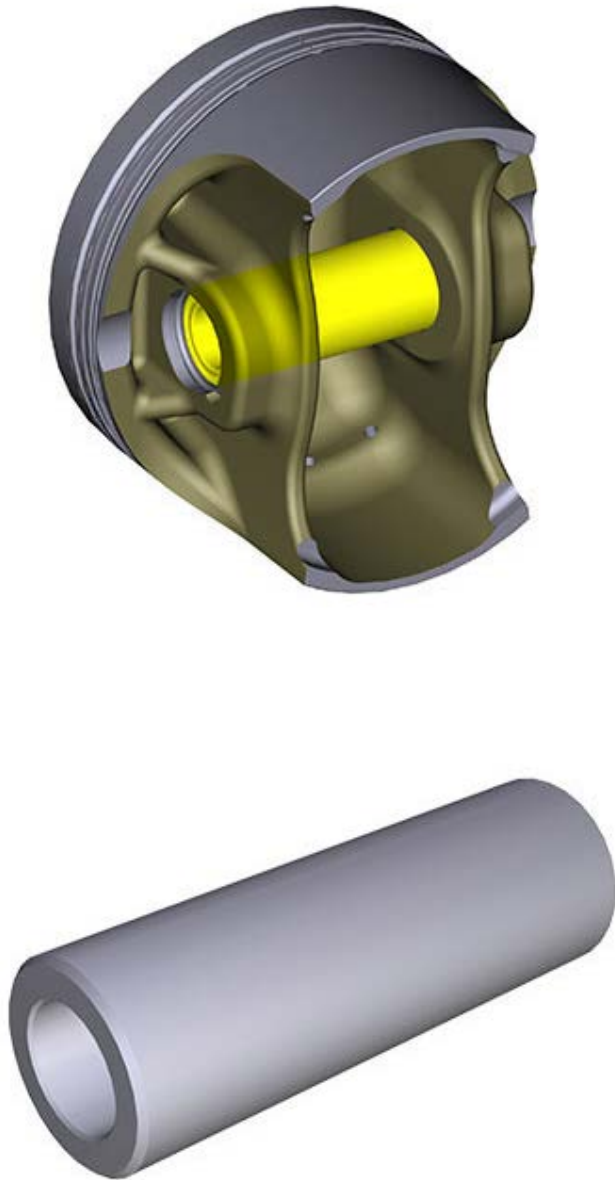

Overhauling the piston rings

The piston rings must not show any signs of scuffing or scoring. Spare pistons are supplied complete with piston rings and gudgeon pin.

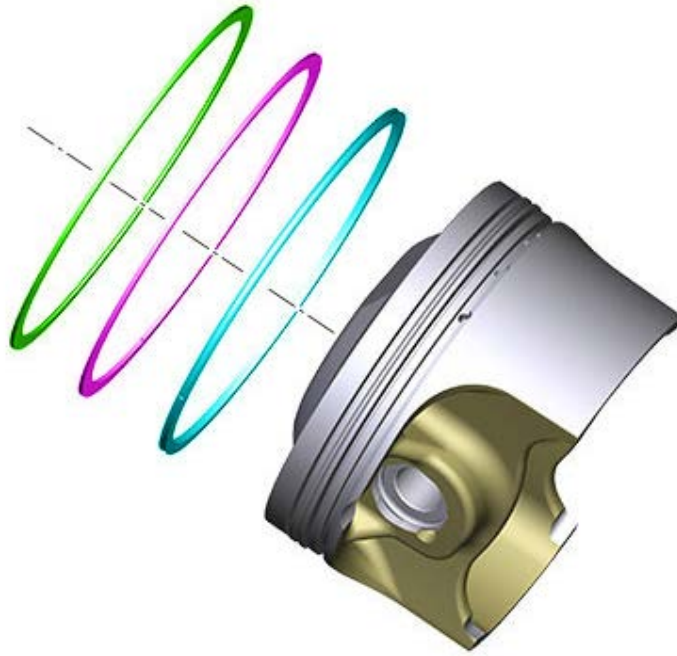

Piston ring-grooves coupling

The maximum permissible wear limit is **0.15 mm** for the upper ring (1st) and **0.10 mm** for the others (2nd and oil scraper ring).



Note

The piston rings must always be fitted with markings facing upwards.

Piston-gudgeon pin coupling

Measure the piston ring gap.

Upper and intermediate ring (nominal): **0.20÷0.40 mm**.

Wear limit: **0.80 mm**.

Oil scraper ring (nominal): **0.30÷0.60 mm**.

Wear limit: **1.0 mm**.

Removing the cylinder/piston assembly

Remove the engine from the frame ([Removing the engine](#)).

Remove the heads ([Removing the engine heads](#))

Slide out of the cylinder surface the pin (1), bushings (2) and head gasket (3).

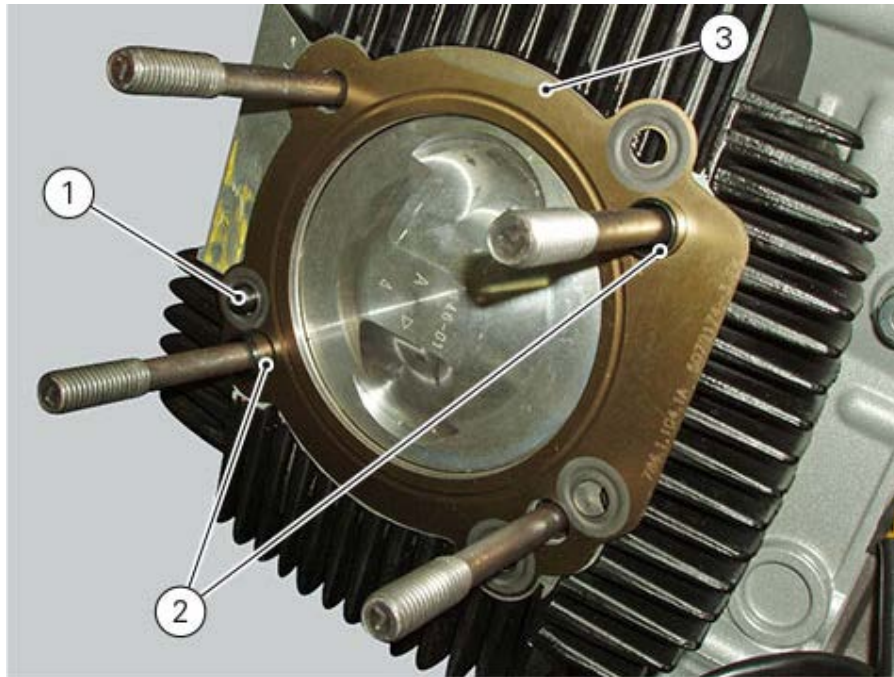

Use tool (A) no. **88700.5644** to bring the piston (4) of the horizontal cylinder (5) near the TDC. Carefully lift the cylinder (4) off the crankcase, keeping it vertical.



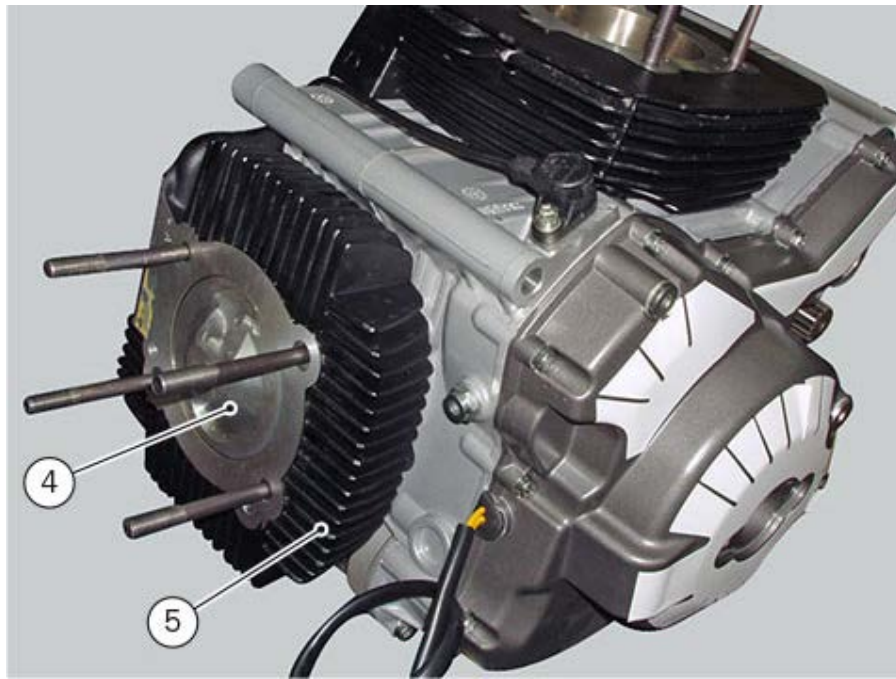

If necessary, rock the cylinder slightly using both hands or tap its base gently with a rubber mallet. Continue to lift the cylinder until you can access the gudgeon pin (6).

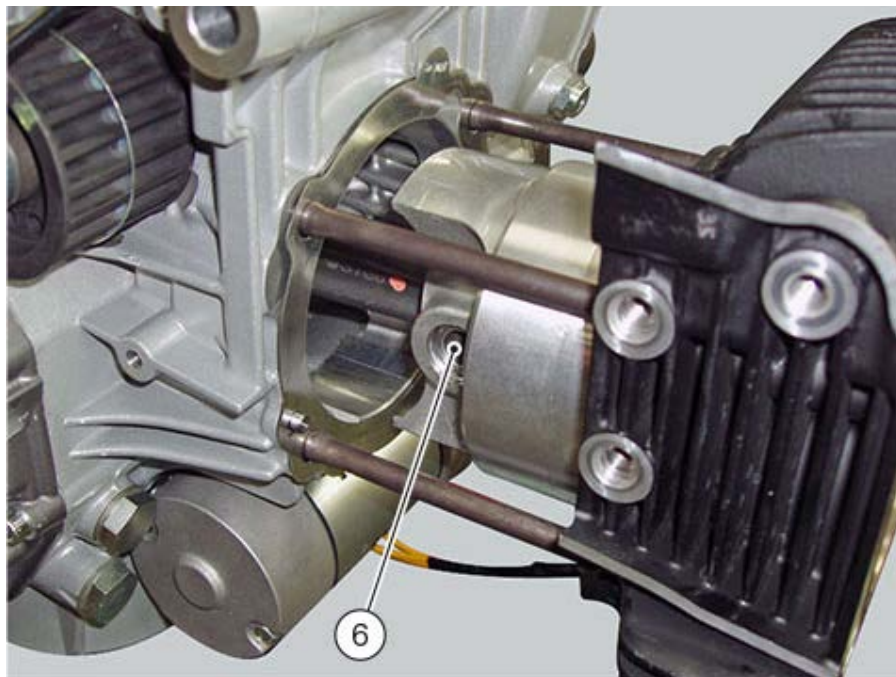

Since insertion of piston in the cylinder is a difficult operation to perform at the time of reassembly, remove the cylinder together with the piston as described below. Block the crankcase opening with a rag or soft paper to prevent foreign material from falling inside. Remove the snap ring (7) from the gudgeon pin (6) on the clutch side.

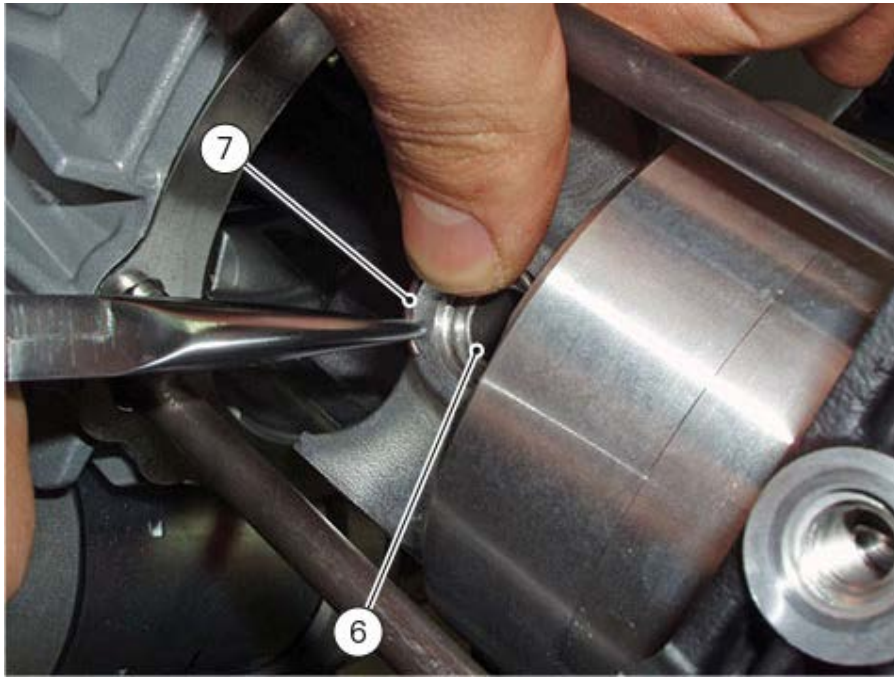

Working from the opposite side, drive out the gudgeon pin (6) sufficiently to release the connecting rod of the crankshaft.
Lift the cylinder-piston assembly clear of the engine block stud bolts.

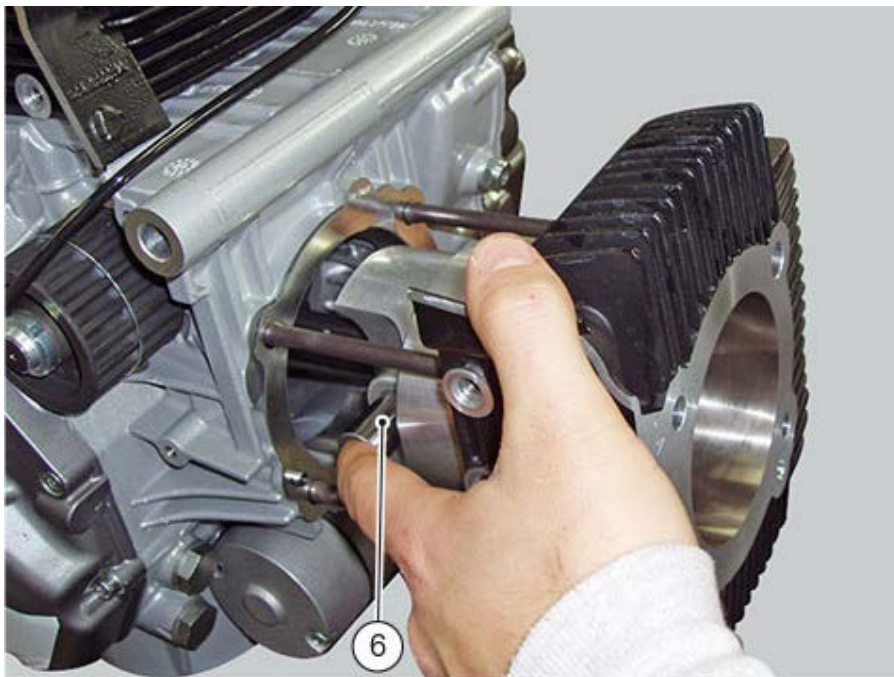

If work is to be carried out on the piston, carefully withdraw it from the cylinder.



To remove the vertical cylinder-piston assembly follow the procedure performed on the horizontal cylinder. Remove gaskets (8) between cylinder and casing.

Important

Mark the pistons to show from which cylinder they were removed:
V= Vertical - O= Horizontal.

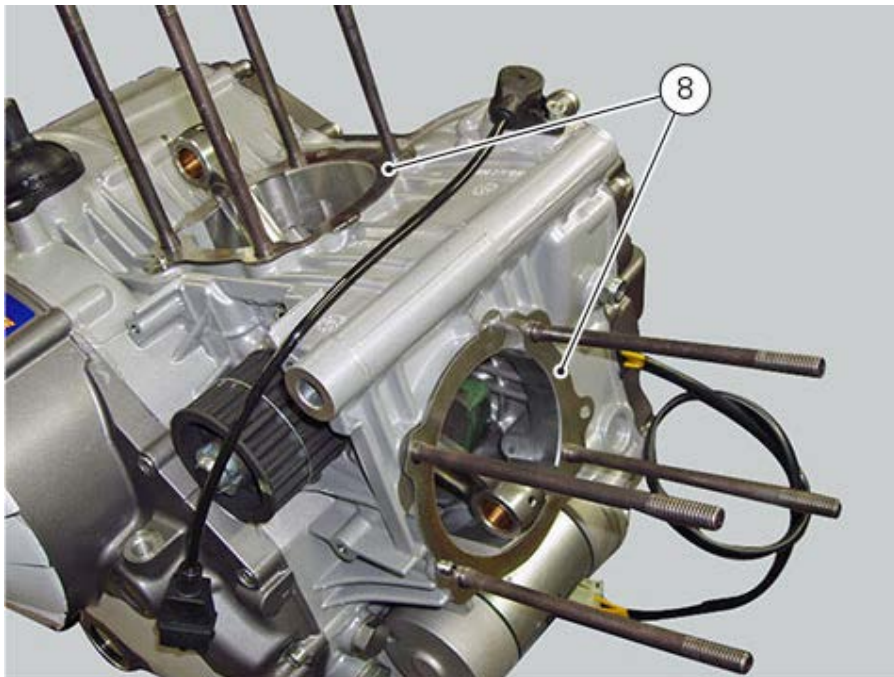

Refitting the clutch

If the hub - plates - drum assy (9) was disassembled, take special care to clutch plate positioning upon reassembling.

Insert the clutch plate pack on hub:

The plate pack (9) consists of:

- 11 driving plates (A) with 2.8 mm thickness;
- 6 driven plates (B) with 2 mm thickness;
- 1 convex driven plate (C) with 1.5 mm thickness;
- 3 driven plates (D) with 2.5 mm thickness.

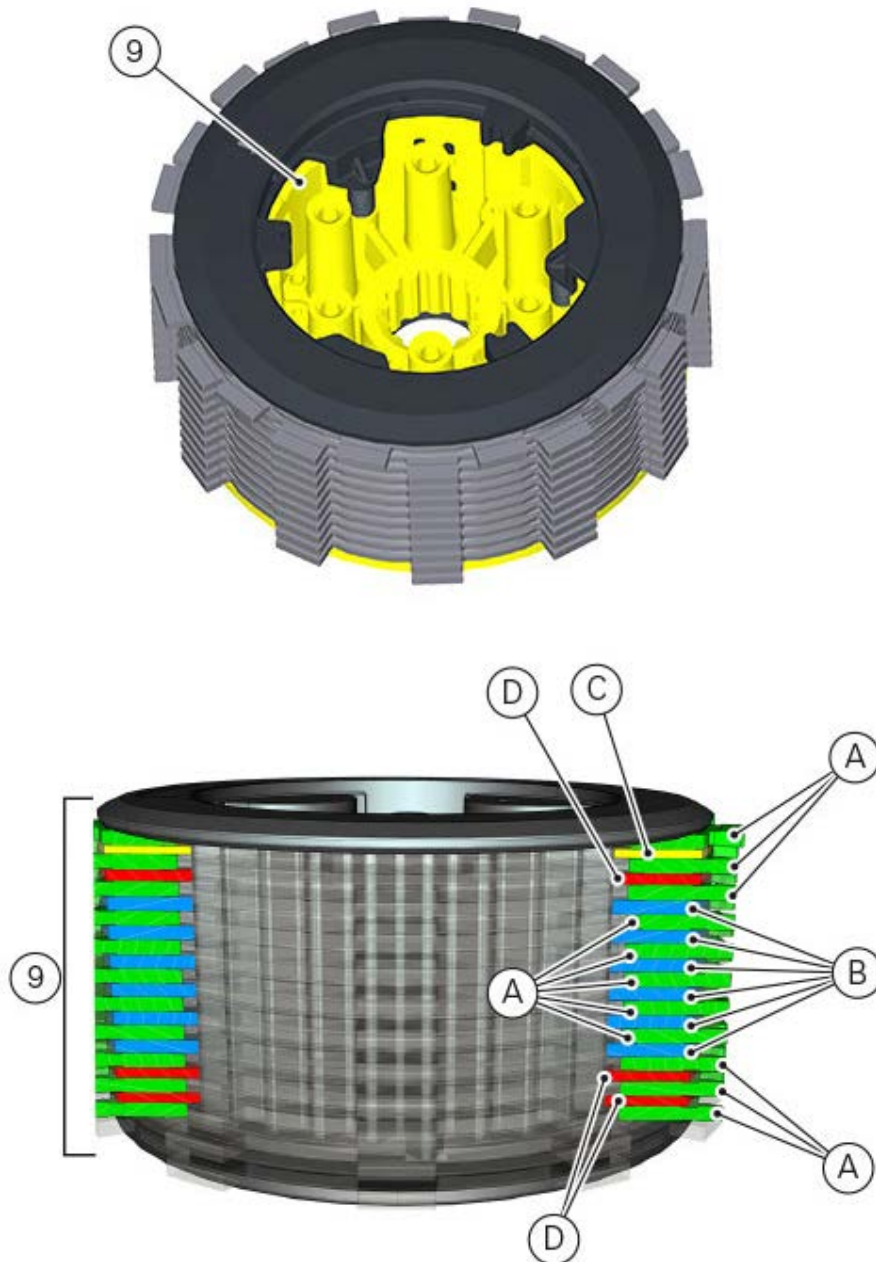

Fit the clutch plate pack with hub inside drum.
Fit the two service pins.

Fit the spacer (11) to the clutch housing (10).

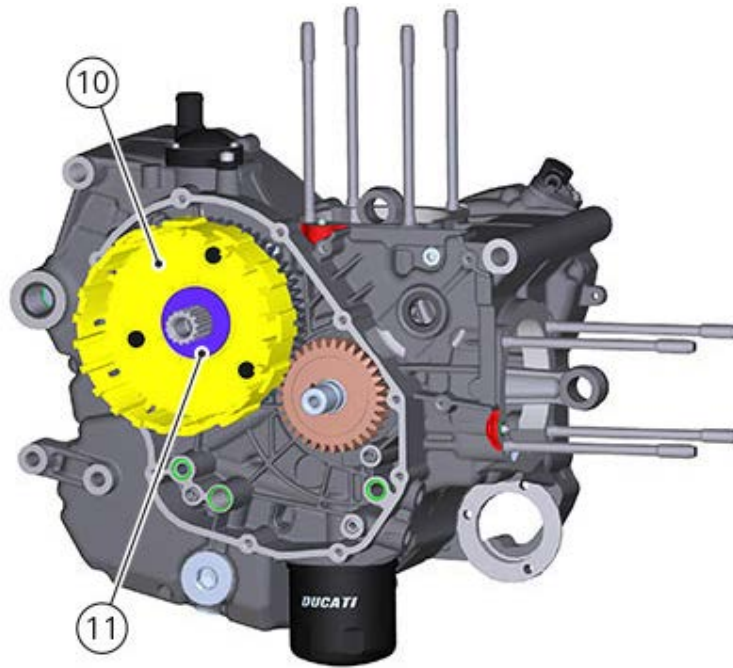

Fit the hub-plates-drum assy (9) to the clutch housing (10).

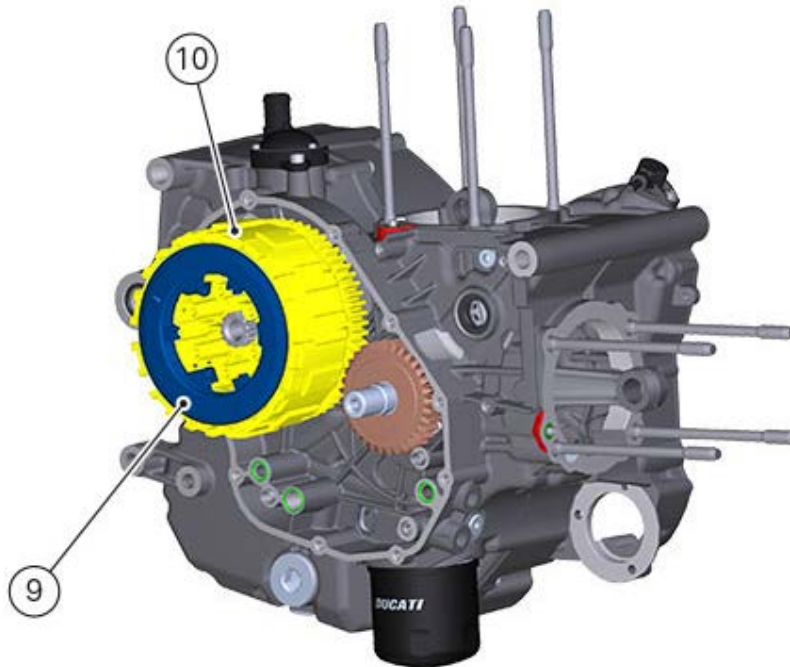

Fit lock washer (8) on primary shaft, driving it fully home inside clutch unit.

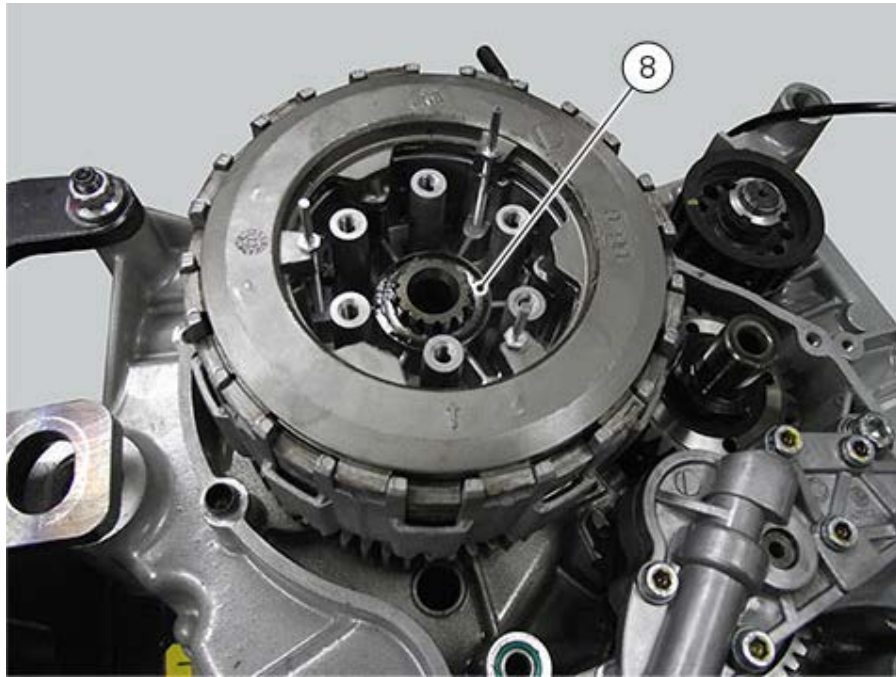

Apply the specified grease on nut (7) mating surface and on primary shaft thread, then insert nut driving it fully home by hand inside primary shaft.
Lock clutch housing with tool (T) no. **88713.2556**, so as to hold it when tightening nut (7).
Tighten nut (7) to a torque of 190 Nm (Min. 180 Nm - Max. 200 Nm).
Remove tool (T) no. **88713.2556**.





Position pusher plate (5) with the clutch control pin (6).

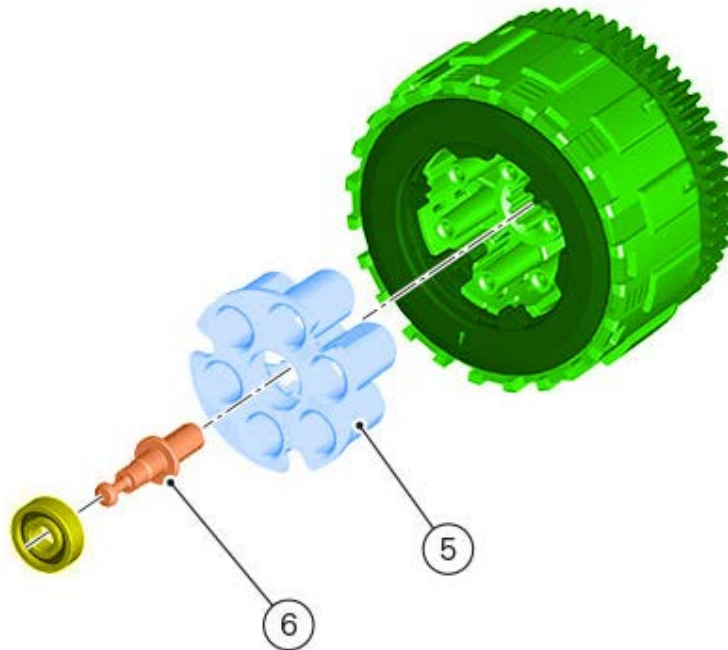

Fit springs (4) and ring (3) on pusher plate (5). Start screws (2) and tighten them to a torque of 5 Nm (Min. 4.5 Nm - Max. 5.5 Nm).

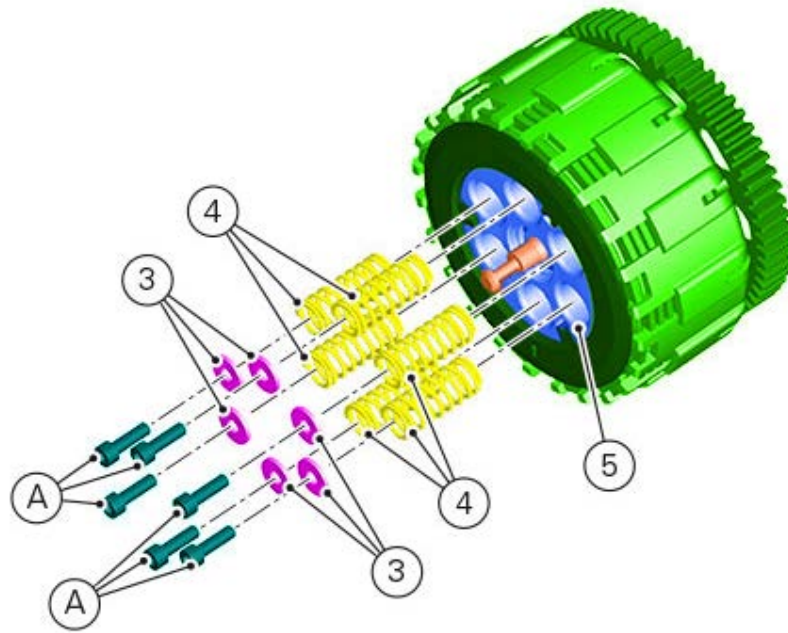

Remove the two service pins (1).

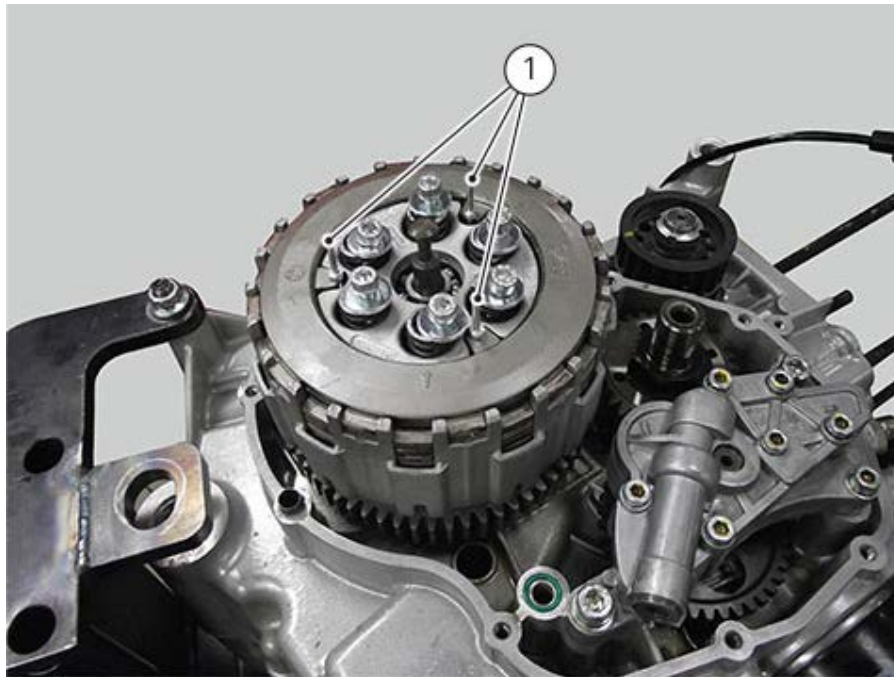

Refit the clutch cover ([Refitting the clutch cover](#)).
Fill the engine with oil ([Changing the engine oil and filter cartridge](#)).

Checking and overhauling the components

Clearance between the clutch housing and friction plate

Insert a friction plate (E) in the clutch housing (F) and measure the clearance (S) with a feeler gauge. Clearance "S" must not exceed 0.6 mm.

If it does, replace the plates and, if necessary, the clutch housing.

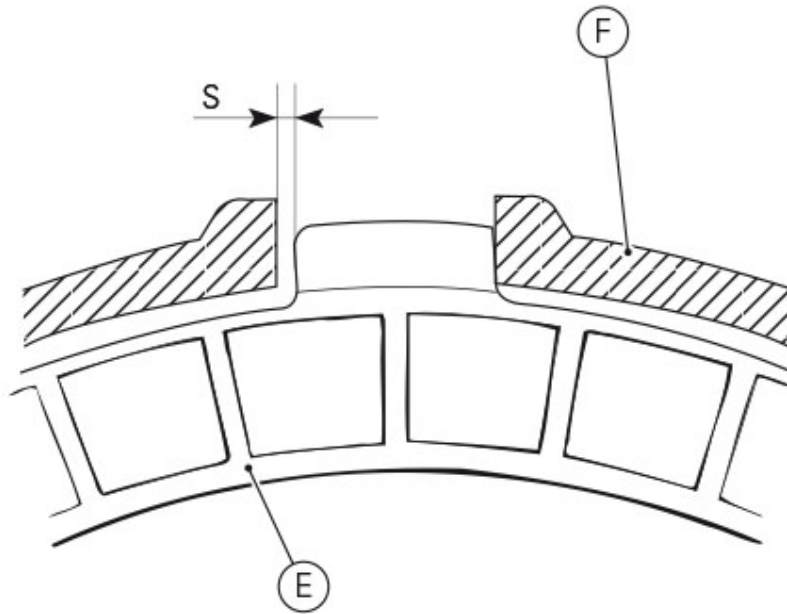

Overhauling the clutch plates

The clutch plates must not show any signs of blackening, grooves or deformation. Measure the thickness of the friction plates; it should not be less than 2.6 mm.

Important

The total thickness of the plates pack must not be less than 46.1 mm.

Place the plate on a flat surface and check the amount of deformation with a feeler gauge. Max. flatness error: 0.2 mm.

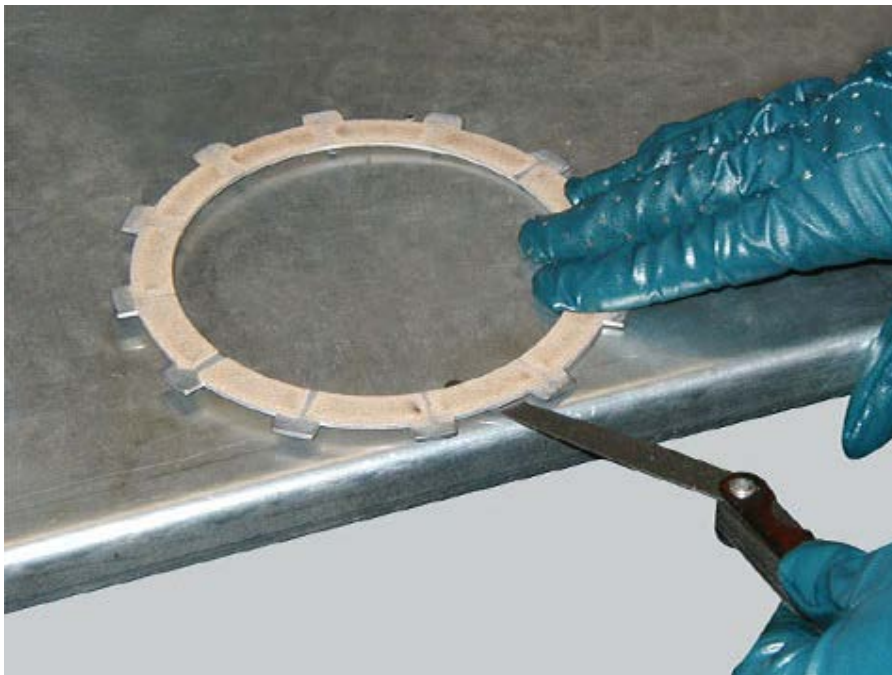

Overhauling the pressure plate

Check bearing (12) conditions: replace the bearing if the play is excessive.
Check the contact surface of the last friction plate; if extremely scored, polish it in the same manner as described previously for the cylinder head surface ([Overhauling the cylinder head components](#)).
Check the condition of the spring guide seats (13) of pusher plate (5).

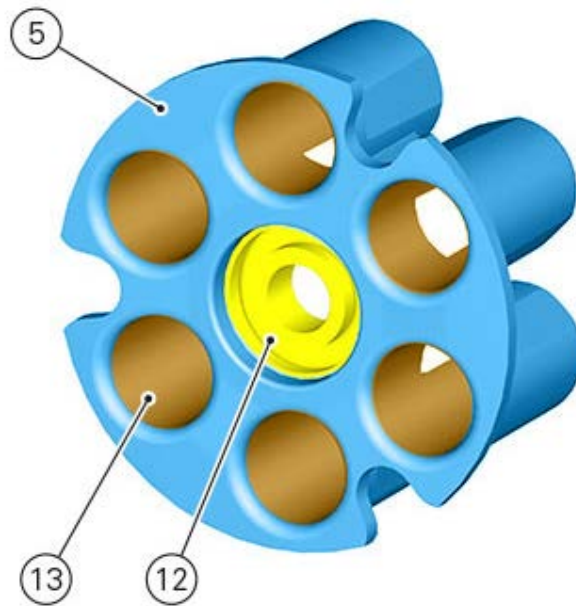

Pusher plate springs

(L) can indicate two lengths:

- uncompressed length = 56.19;
- working length = 42.6.

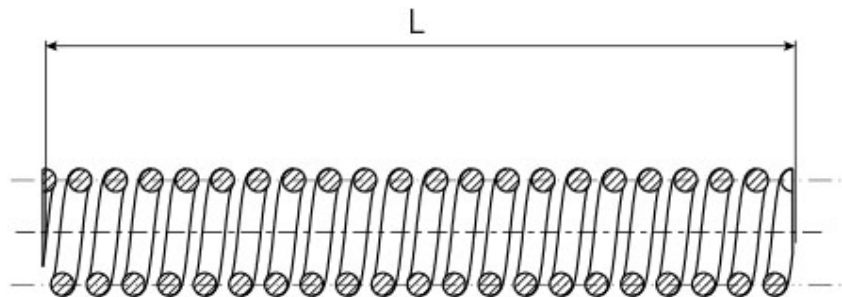

Removing the clutch

Drain the engine oil ([Changing the engine oil and filter cartridge](#)).

Remove the clutch cover ([Removing the clutch cover](#)).

Fit the two service pins (1) inside their seats on hub.

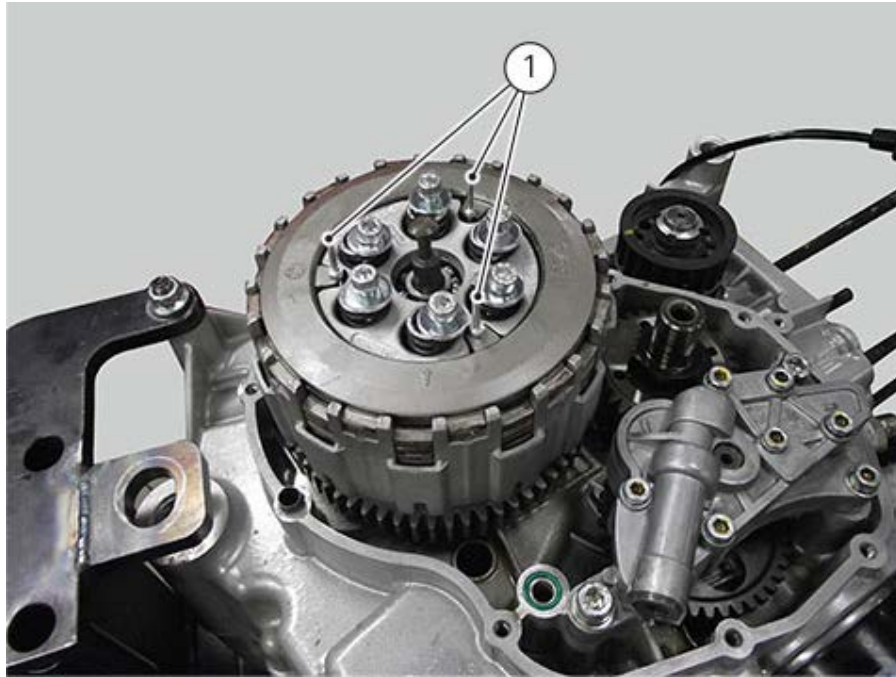

Undo the fixing screws (2) and remove the ring (3) and the springs (4) from the pusher plate (5).

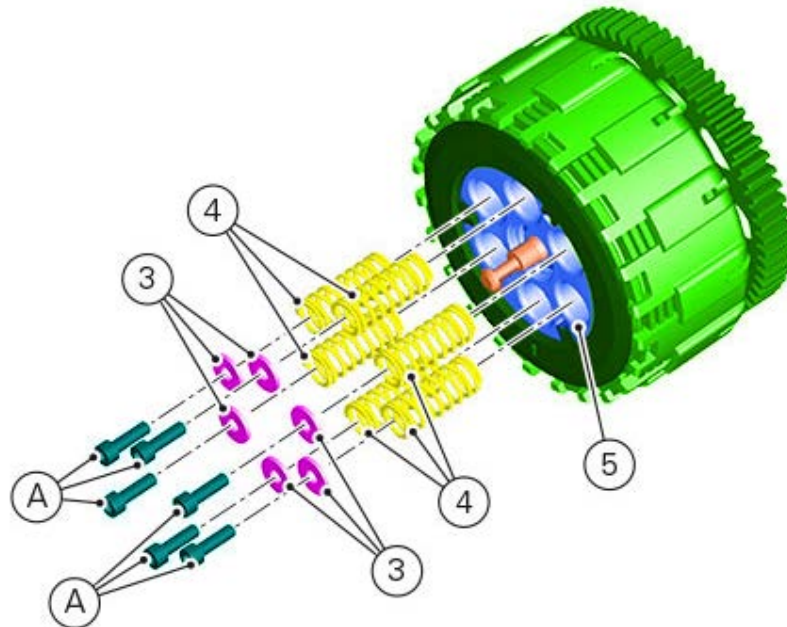

Slide out the pusher plate (5) with the clutch control pin (6).

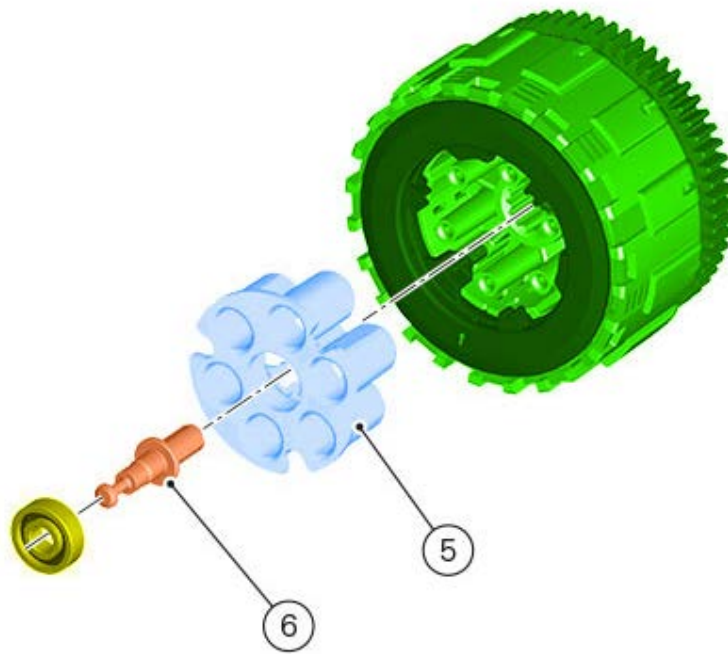

Lock clutch housing with tool (T) no. **88713.2556** and loosen retaining nut (7).



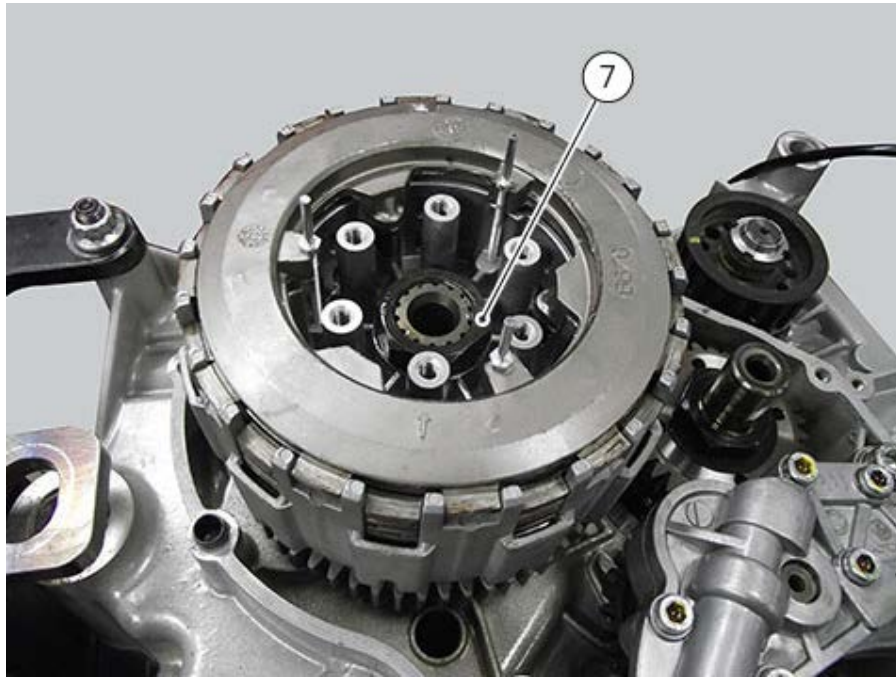

Remove the lock washer (8).

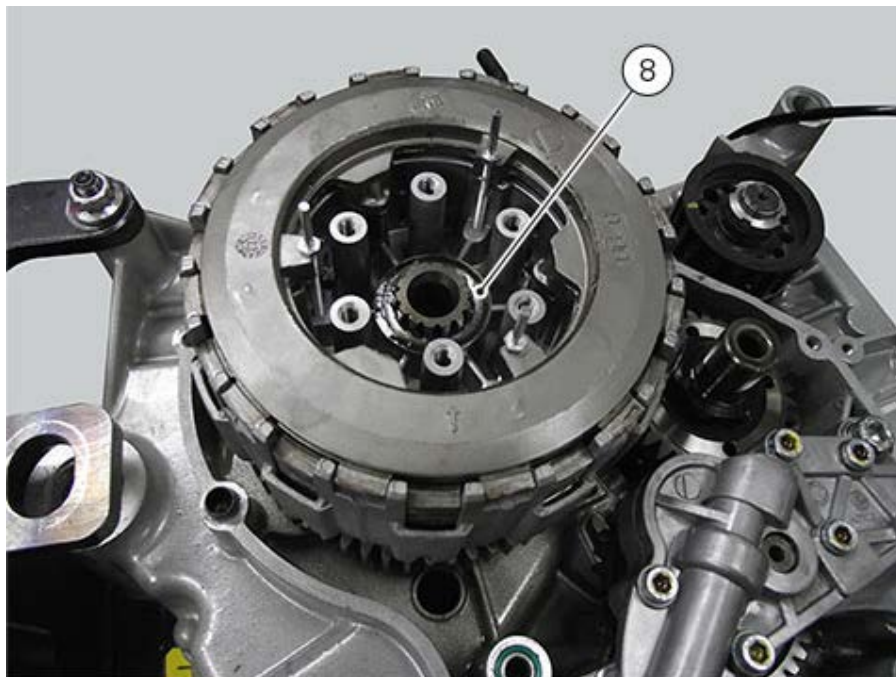

Slide the hub-plates-drum assy (9) out of clutch housing (10), marking them so as to refit them in the same position in which they were removed.

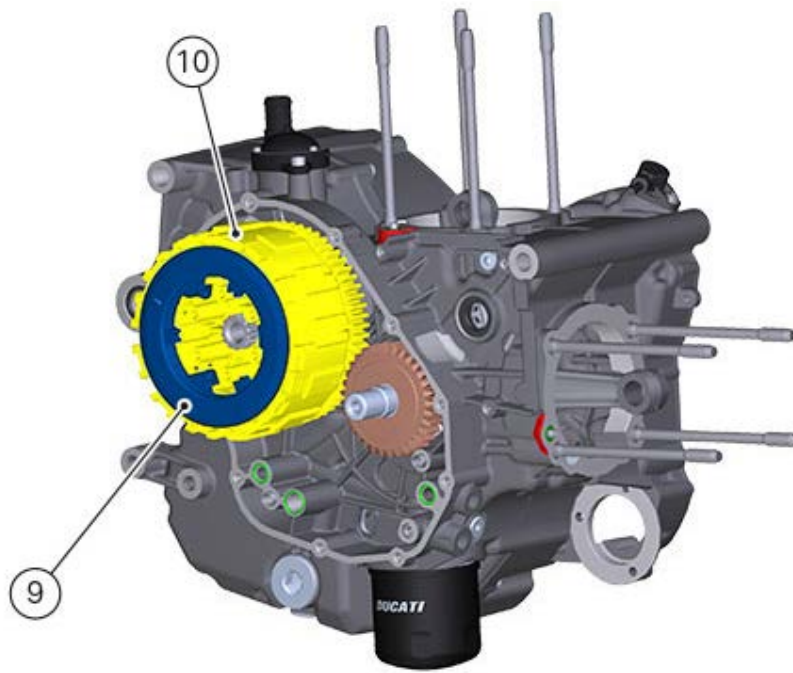

Remove the spacer (11) from the clutch housing (10).

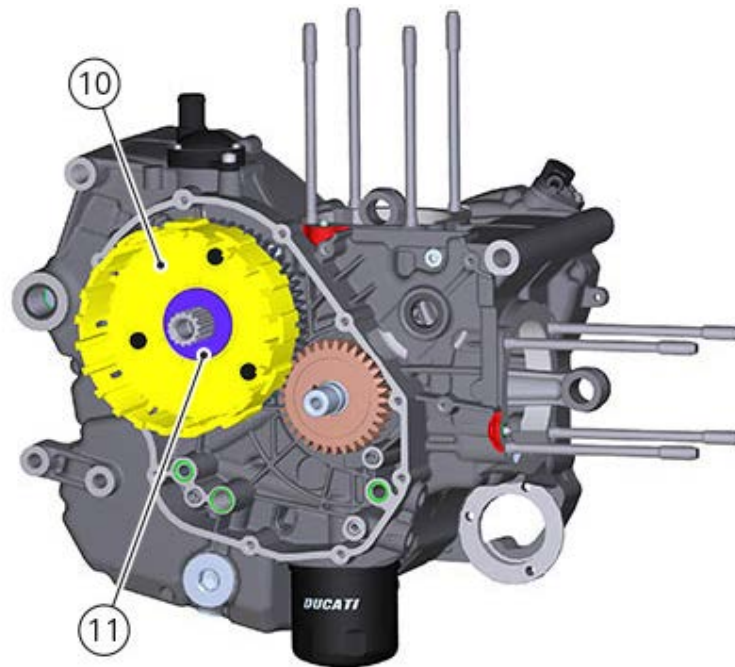

Description of the clutch assembly

The clutch is disengaged by a drive unit (lever (A) and spring) positioned on clutch cover. The drive unit directly operates on clutch control pin (B) that, in its turn, operates the pressure plate (C) positioned at the top of plate pack (D).

Drive is transmitted from the crankshaft to the gearbox primary shaft by a gear integrated with the clutch housing/primary drive gear pair (A).

Accommodated in the clutch housing is a set of driving and driven plate pack (D). When the clutch is operated, the driven plates push away a drum (3) which is splined onto the gearbox primary shaft.

Before working on the internal clutch parts, check that the clutch operates correctly. Then deal with the problem in a systematic manner.

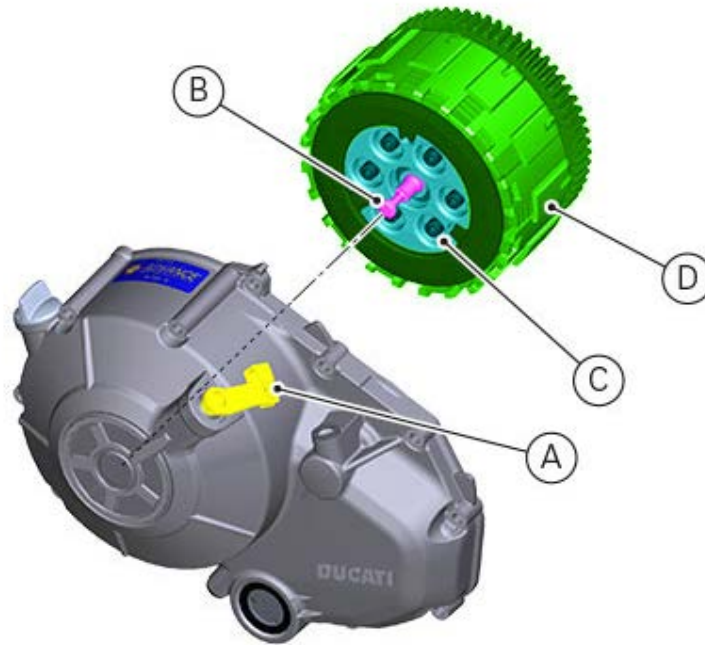

The following is a list of possible causes of clutch malfunction.

A clutch which does not disengage may be caused by:

- excessive play of the control lever;
- distorted clutch plates;
- incorrect spring tension;
- faulty clutch release mechanism;
- excessive wear of the hub or clutch housing.

A clutch which slips may be caused by:

- no backlash of the control lever;
- worn clutch plates;
- weakened springs;
- faulty clutch release mechanism;
- excessive wear of the hub or clutch housing.

A noisy clutch may be caused by:

- excessive backlash between the primary drive gears;
- damaged primary drive gear teeth;
- excessive housing between driving plate tabs and the clutch housing;
- worn gear/clutch housing bearings;
- the presence of metal particles (filings) on the gear teeth.

Refitting the clutch cover

Clean and degrease cover and casing mating surfaces. Check that the casing features the centring bushing (7).

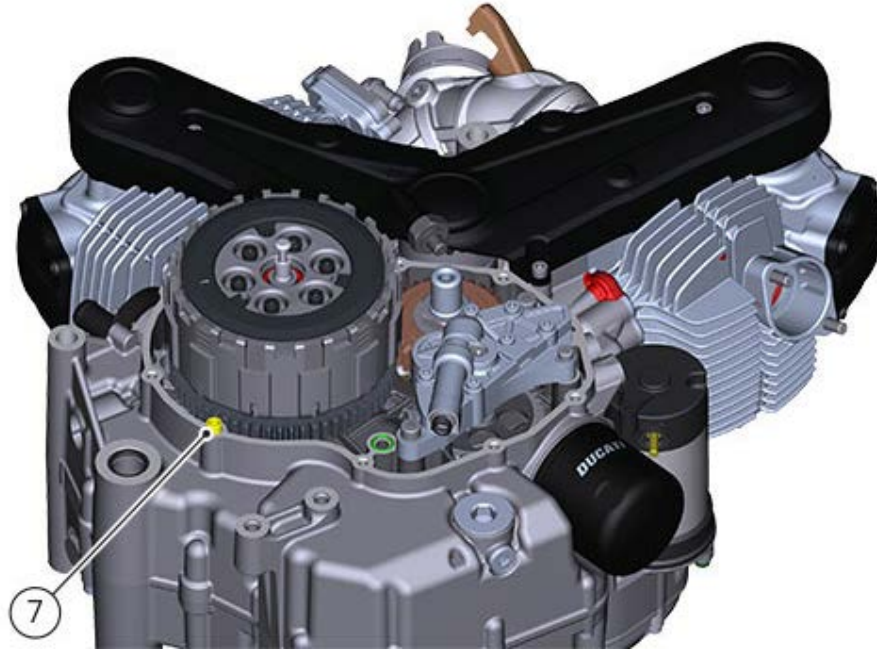

Apply an even, regular bead of DUCATI sealing compound (A) on the mating surface of the crankcase half and around all holes.

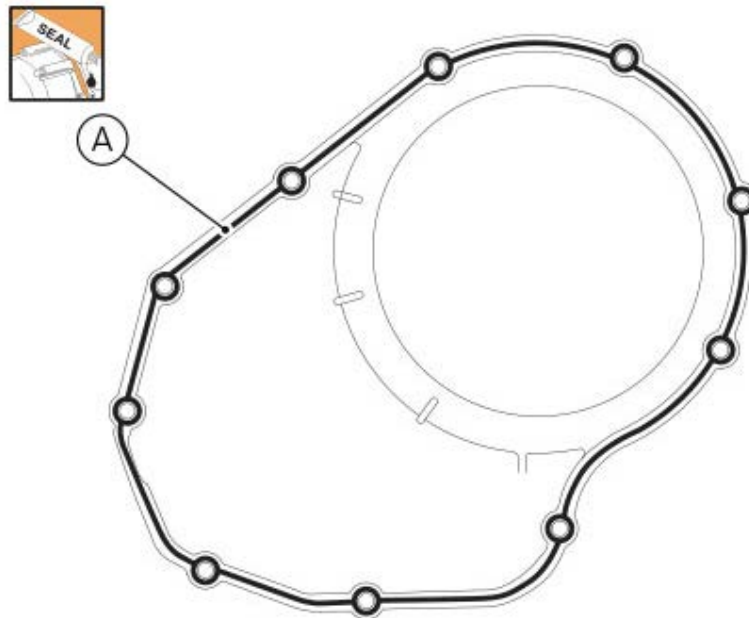

Bring cover near the crankcase half and, operating on clutch cover lever, make sure that clutch control pin is duly inserted inside its seat on cover.

Start the fastening screws (2), (3) and (4) inside the clutch cover.

Ref.	Quantity	Description
2	3	M 6 x 80
3	1	M 6 x 90

Tighten the screws to a torque of 13.5 Nm (Min. 12.5 - Max. 14.5).

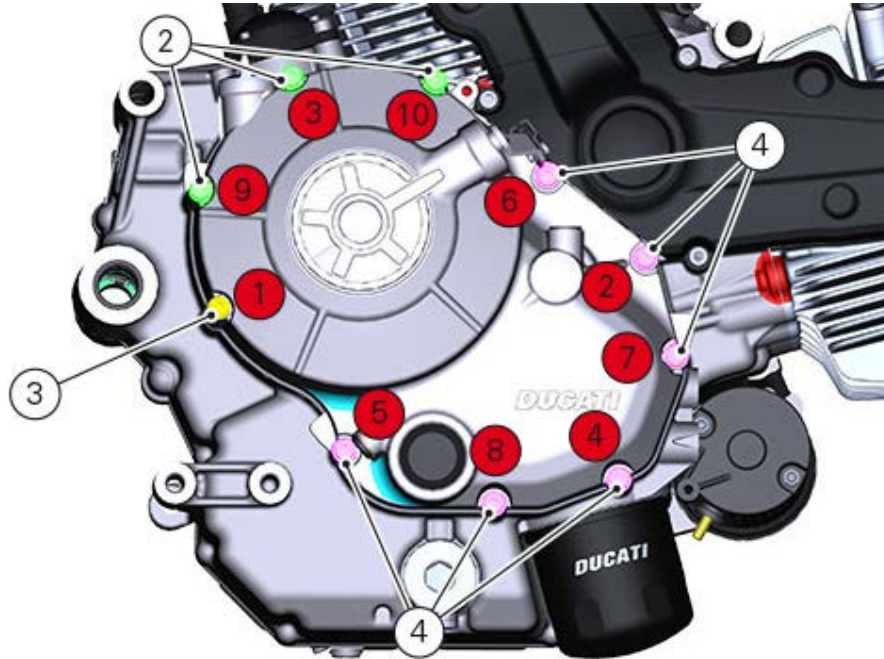

Refit the clutch cable on the clutch cover.

Turn adjuster (6) to tension clutch cable (5) on handlebar.
Screw adjuster (5).

Adjuster (6) standard adjustment is 5 mm from the fully home position.
The maximum adjustment is of 11 mm.

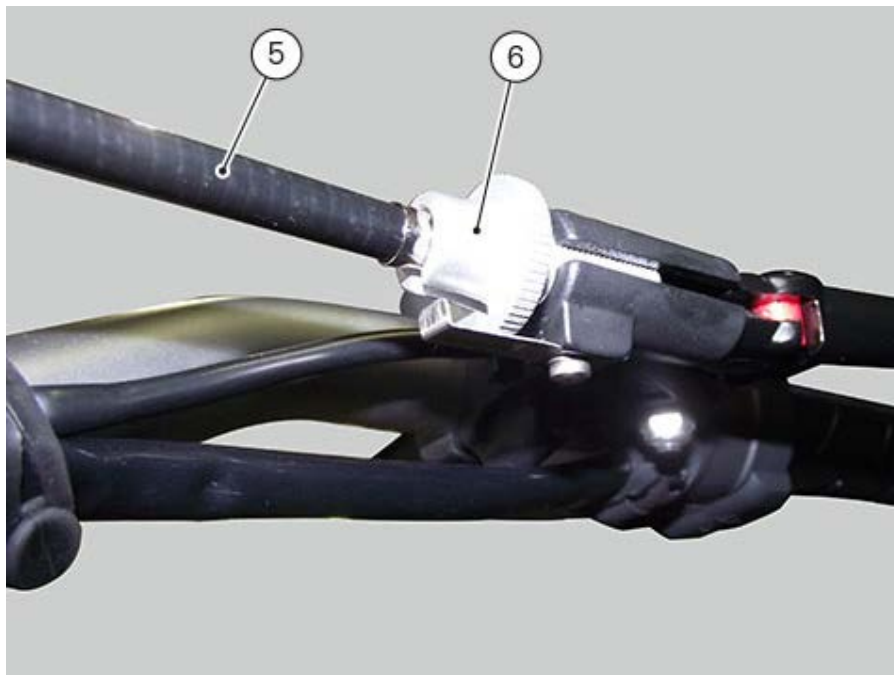

Reposition cable (5) on the clutch cover.

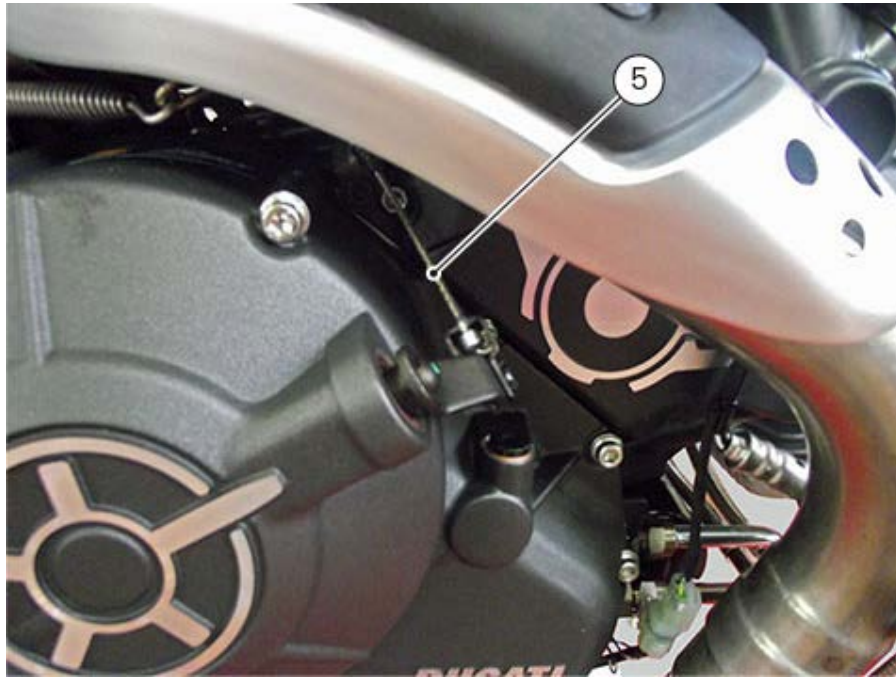

Fill the engine with oil (Changing the engine oil and filter cartridge).

Reassembling the clutch cover

Clutch layshaft

Use the indicated product to lubricate the clutch layshaft (9) in the points indicated in the figure.

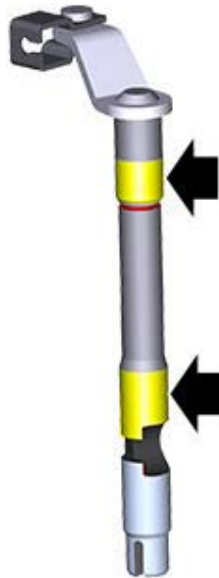

Lubricate seal (10) using the specified product.
Using a suitable tool, drive ring (10) in the clutch cover seat.

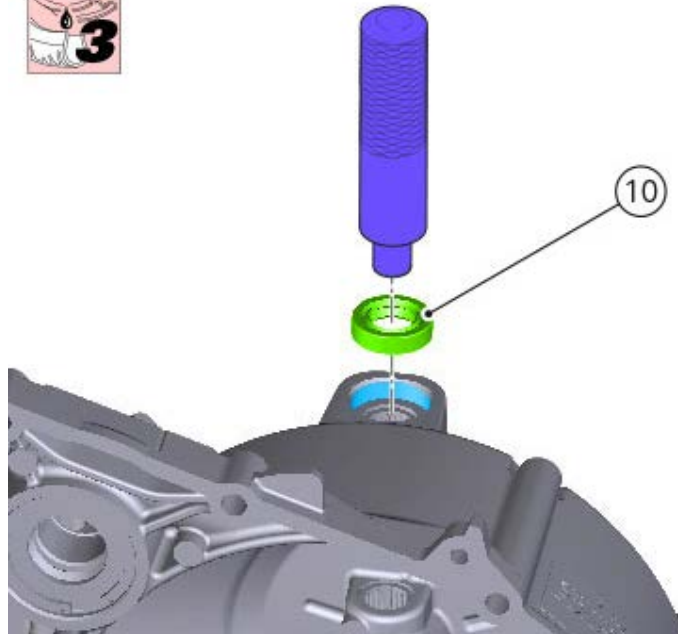

Insert clutch layshaft (9) in seal ring (10) having care not to damage it.
Position spring (11). Part (12) must be engaged in recess (13) of shaft (9).

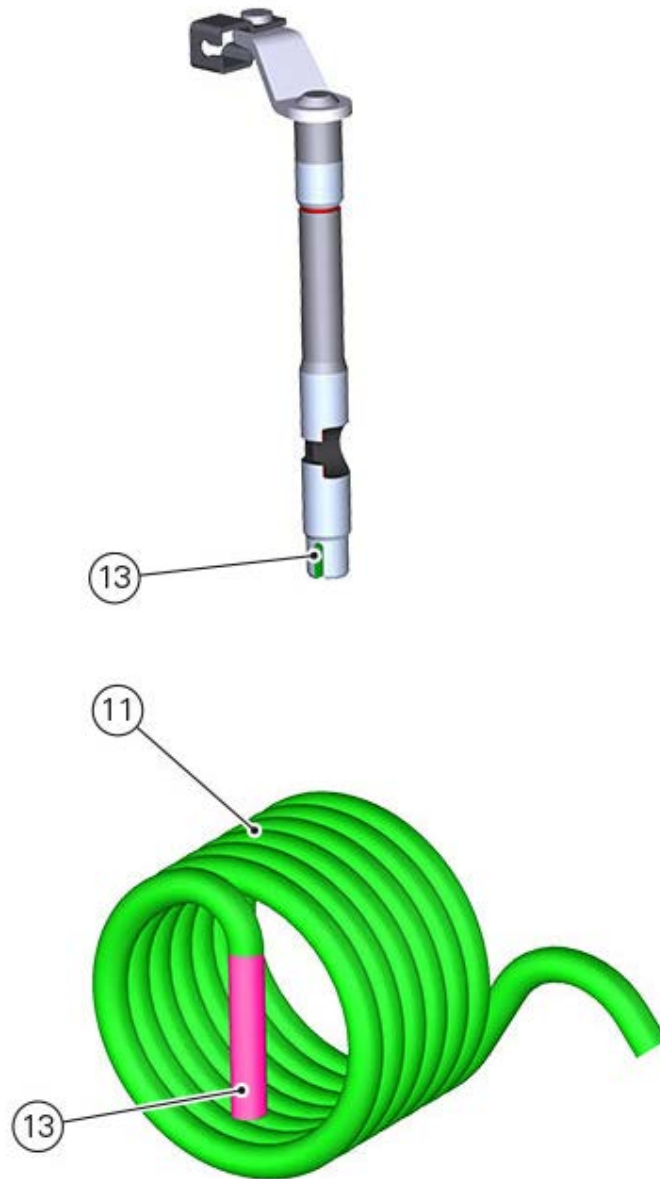

Bring shaft (9) fully against clutch cover (2).
Rotate shaft (9) counter clockwise until part (14) touches mating surface (15).

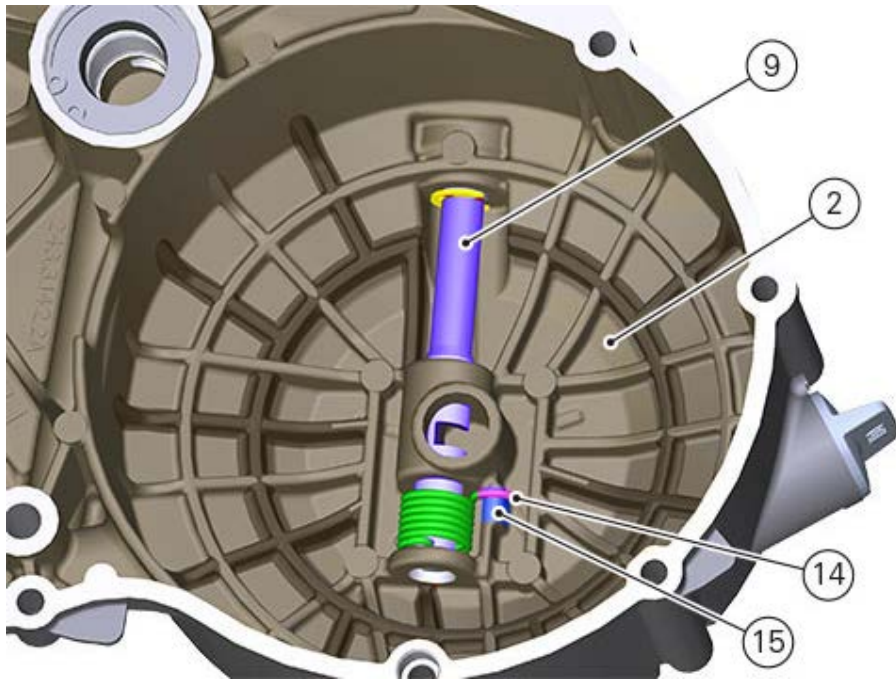

Fit snap ring (8) on pin (9) and perform a functional test.

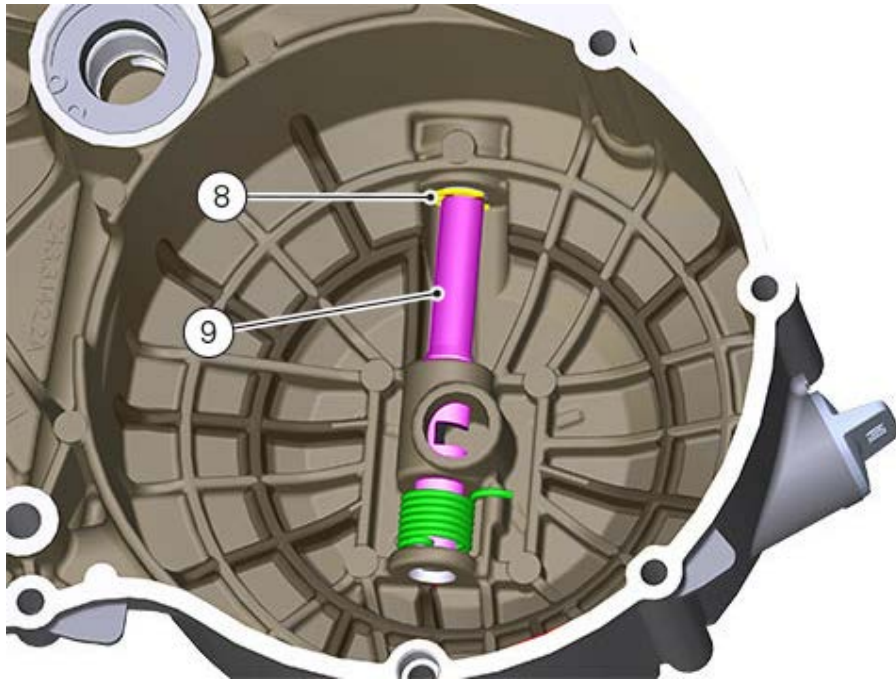

Oil filler cap

Make sure that the oil filler cap (6) has O-ring (7).
Position plug (6) on cover (2) and tighten it to a torque of 5 Nm (Min. 4.5 Nm - Max 5.5 Nm).

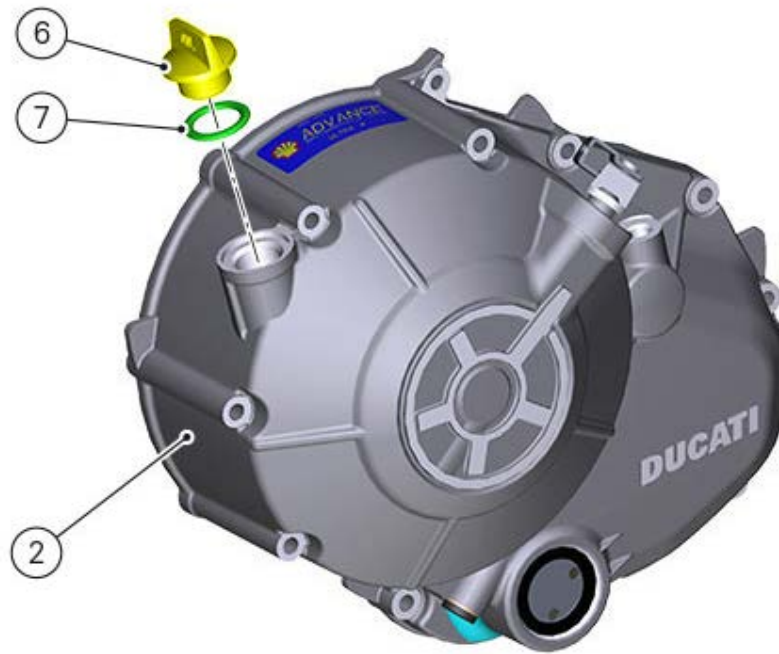

Use the indicated product to lubricate the seal ring (18) and fit it into seat with a suitable tool. Fit spacer (17) and snap ring (16).

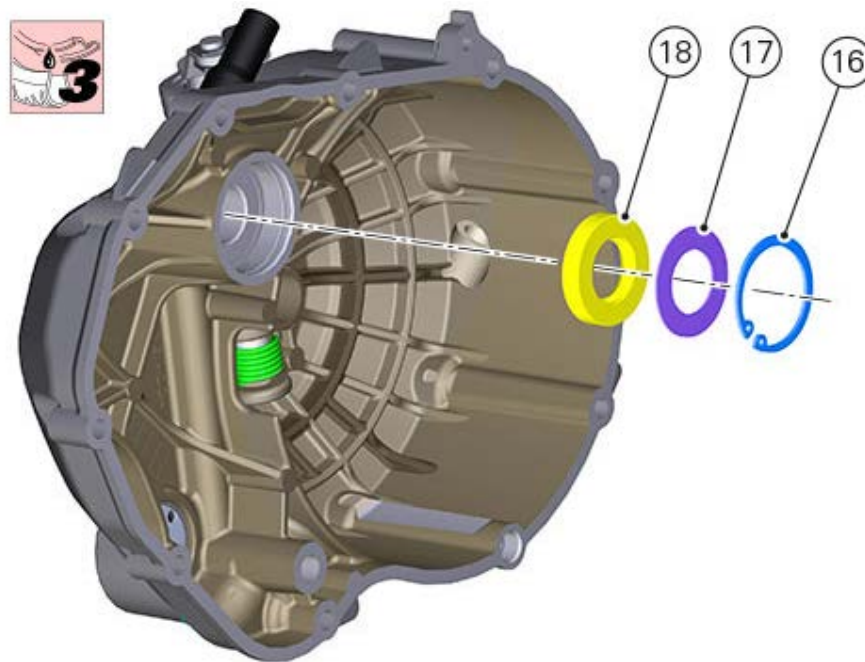

Oil sight glass

If previously removed, refit the sight glass:
 Lubricate sight glass (19) with specified product.
 Using a suitable drift, fit the sight glass to the value indicated in the figure.
 Make sure that two of the four holes (20) are parallel with the cover bottom (21).

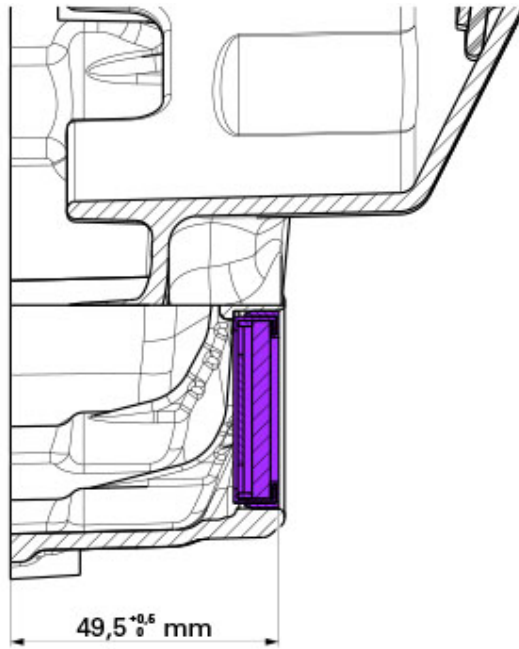
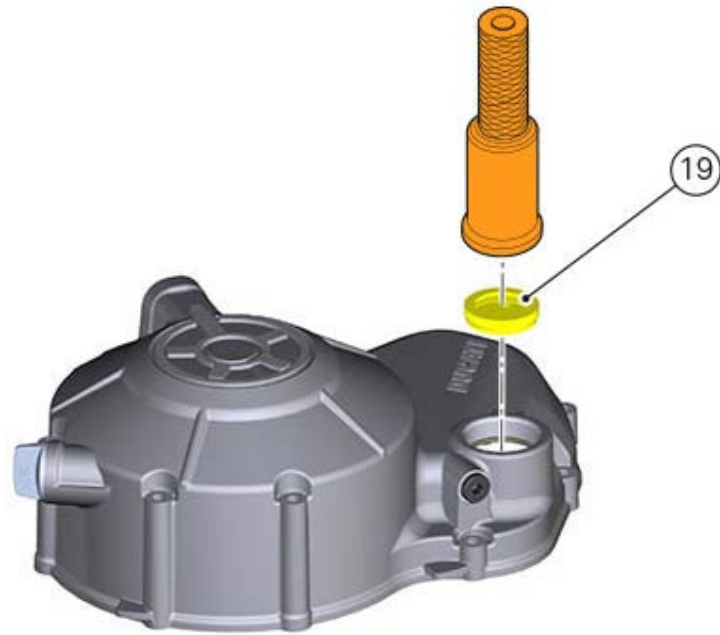

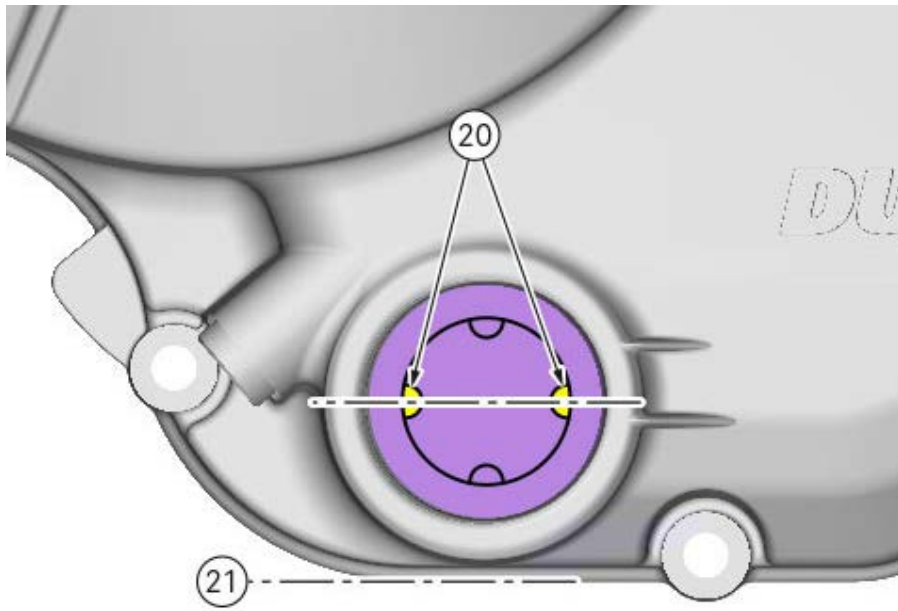

Disassembling the clutch cover

Oil filler cap

Remove the plug (6) with its O-ring (7) from cover (2).

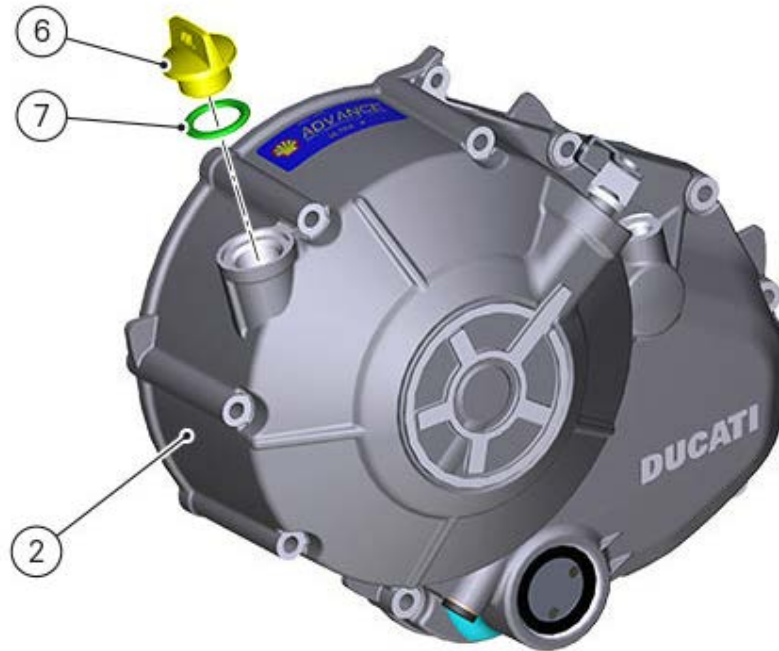

Clutch layshaft

Remove snap ring (8) from clutch layshaft (9).

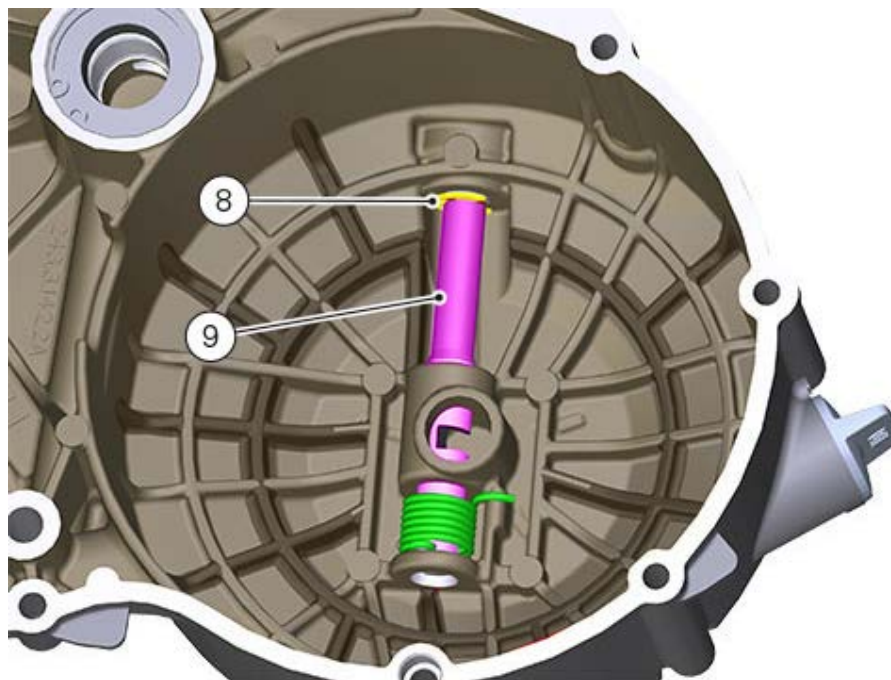

Remove the clutch layshaft (9).

Removing the clutch cover

Drain the engine oil ([Changing the engine oil and filter cartridge](#)).

Loosen the fastening screws (2), (3) and (4) on the clutch cover (1).

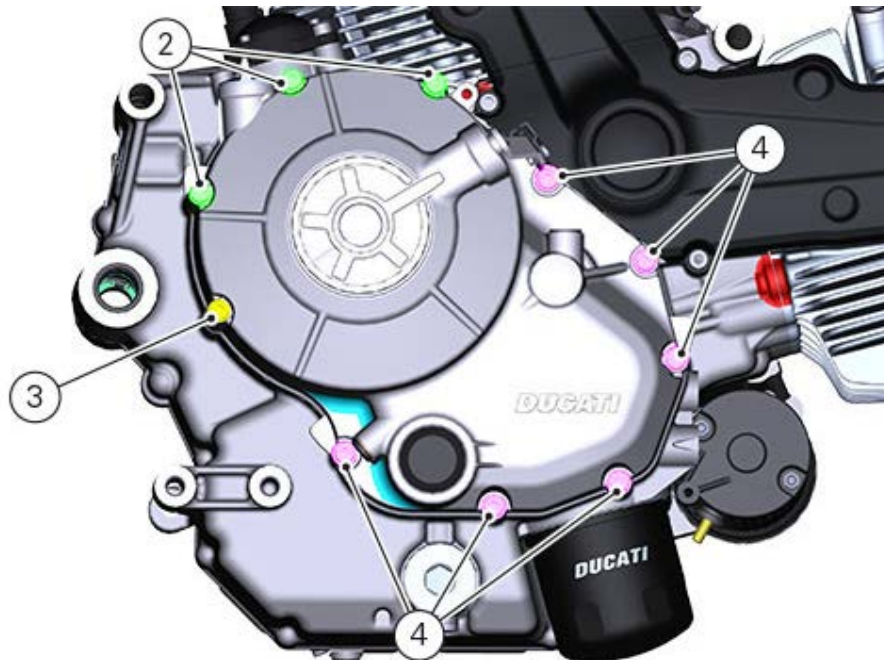

Screw clutch cable (5) fully home on clutch lever on handlebar, working adjuster (6).

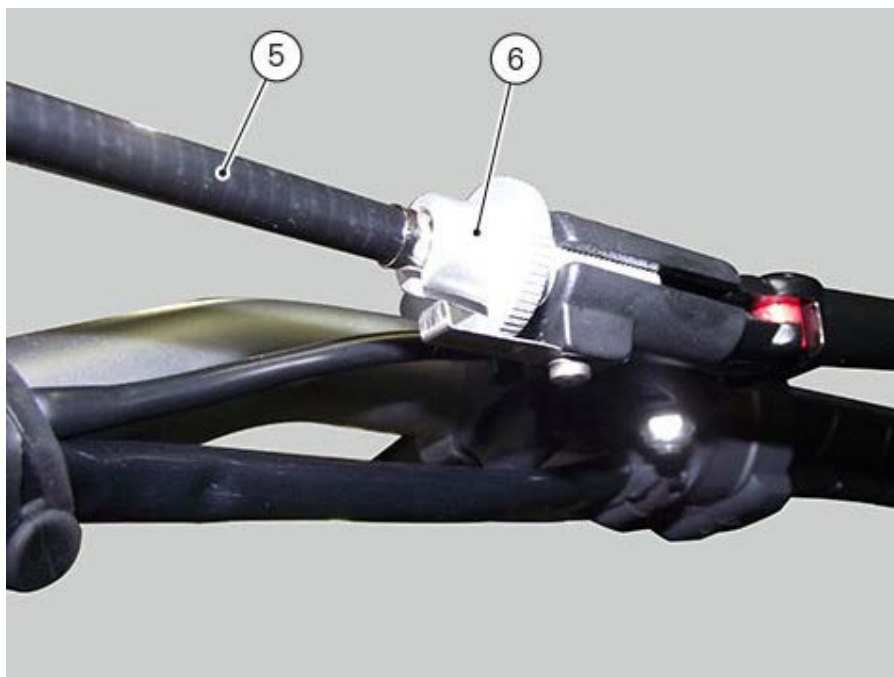

Remove the clutch cable (5) from the clutch cover.

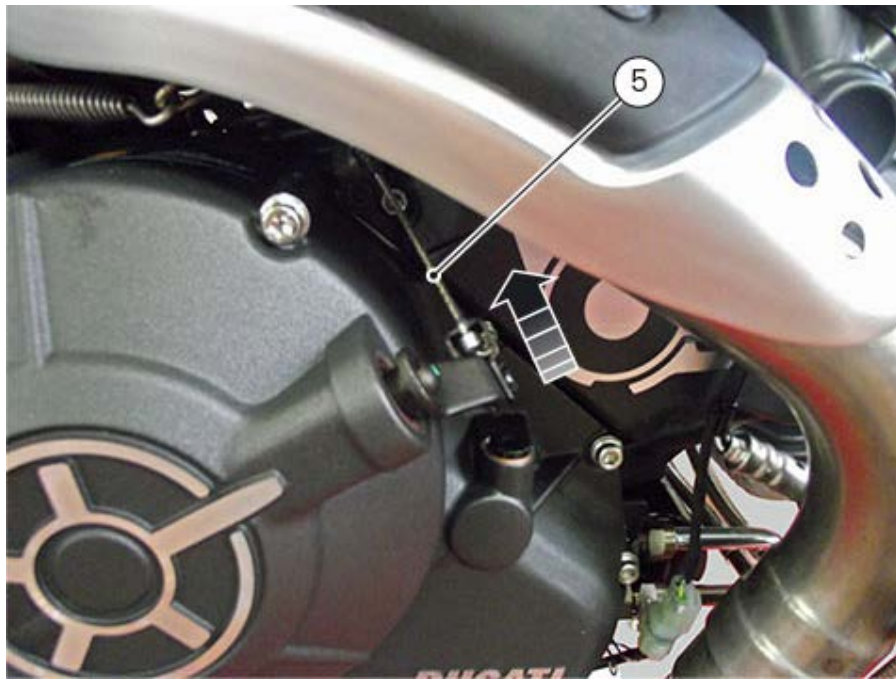

Working on clutch cover lever, slowly remove cover to release it from clutch control pin.

Refitting the primary drive gears and checking backlash

Fully degrease the crankshaft splined end and the corresponding spline on the primary drive gear. Check that tab and inner spacer are positioned on the crankshaft.

Fit the driving gear onto the crankshaft with the oil pump drive sprocket facing the crankcase. Temporarily secure the gear with the washer (6) and ring nut (7).

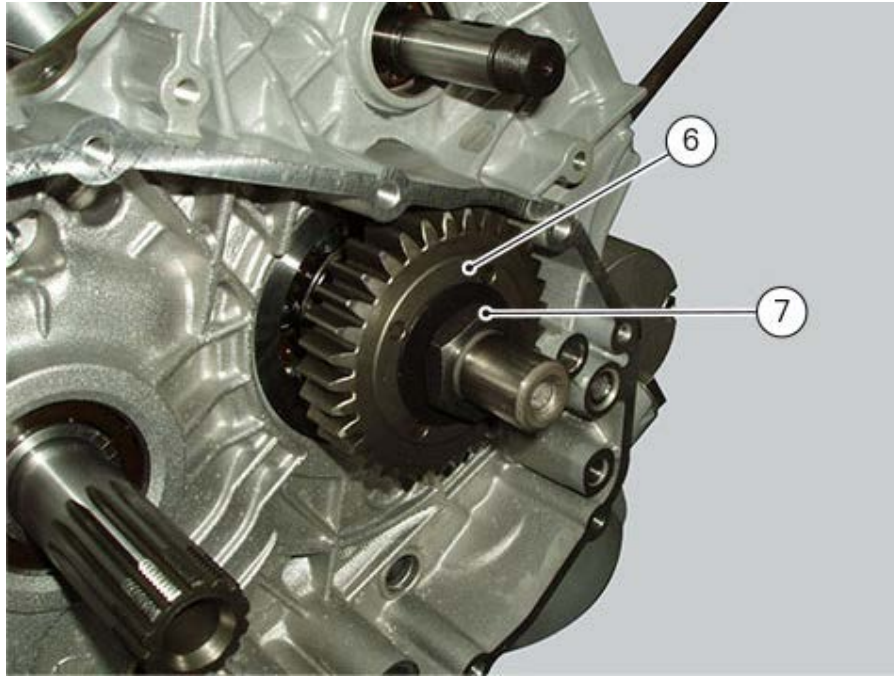

To check the backlash, temporarily fit the clutch housing (1) complete with inner spacer (4), the driven gear (2), the roller bearing (3) and the inner race on the gearbox primary shaft.

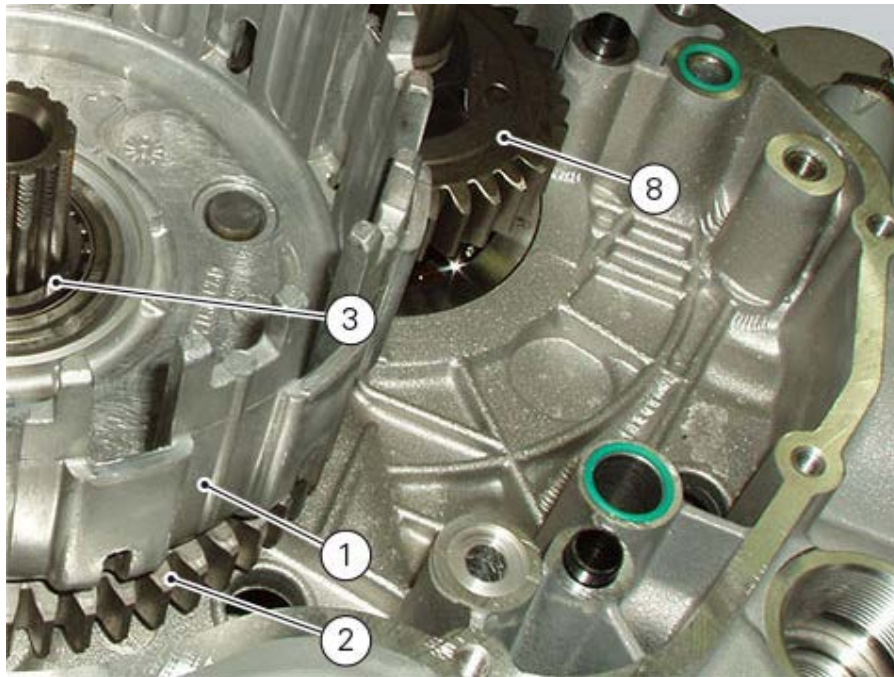

Warning

If fitting a new primary driving gear, check the backlash.

Fix a dial gauge to the crankcase, positioning the stylus against a gear tooth. Turn the driven gear (2) to mesh the teeth and check that backlash ranges between **0.05** and **0.07** mm. Repeat the check at 16 different points of the driven gear.

If the measured values are outside the tolerance limits, try changing the position of driven gear (2) on the primary shaft, leaving the driving gear (8) on the crankshaft in the same position.

If the backlash is still outside the tolerance limits, replace the complete primary drive gear (1).

After having checked the backlash, lock gear (8) using reaction tool no. **88713.2423**, apply the specified grease on ring nut (7), and tighten it to a torque of 190 Nm (Min. 171 Nm - Max. 209 Nm). Bend the washer (6) over ring nut (7).

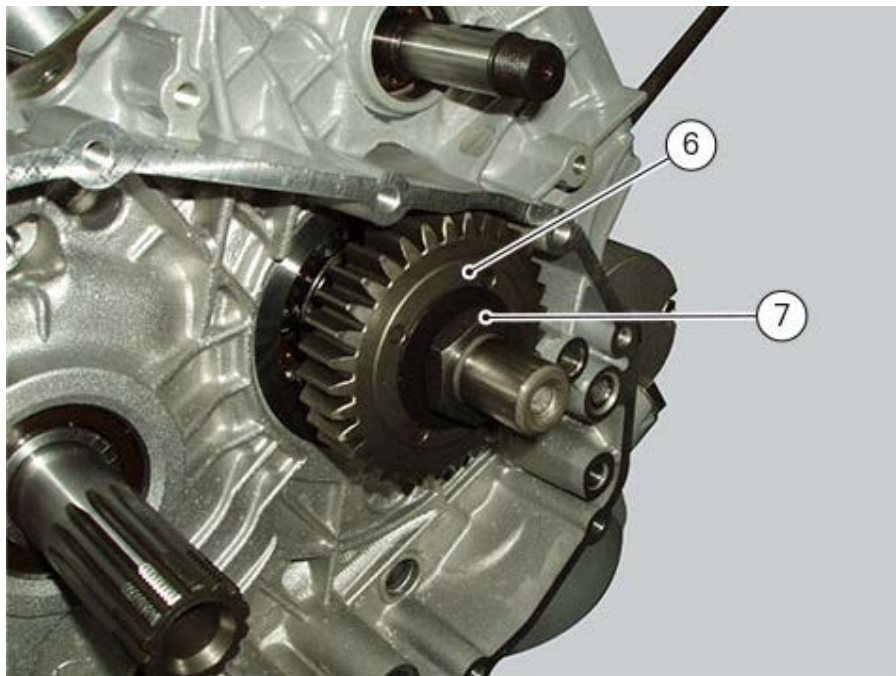

Refit the oil pump and check the backlash between the oil pump gear and the primary drive gear on the crankshaft.

Thoroughly degrease the mating surfaces of the clutch housing (1) of internal bearing (3).

Insert inner spacer (4) inside primary shaft, with the flat side facing outside.

Fit the inner ring (5), the clutch housing (1) along with the driven gear (8) with needle bearing (3).

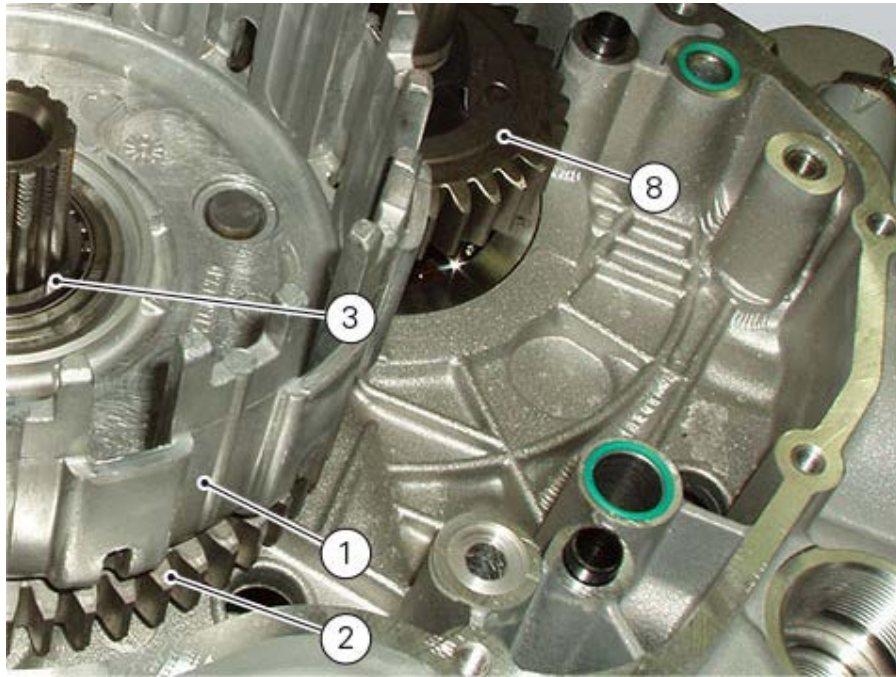

Refit the clutch unit ([Refitting the clutch](#)).

Refit the clutch cover ([Refitting the clutch cover](#)).

Fill the engine with oil ([Changing the engine oil and filter cartridge](#)).

Removing the primary drive gears

Drain the engine oil ([Changing the engine oil and filter cartridge](#)).

Remove the clutch cover ([Removing the clutch cover](#)).

Remove the clutch unit ([Removing the clutch](#)).

Remove the oil pump ([Removing the oil pump](#)).

Remove the clutch housing (1) complete with needle bearing (3) and primary driven gear (2).

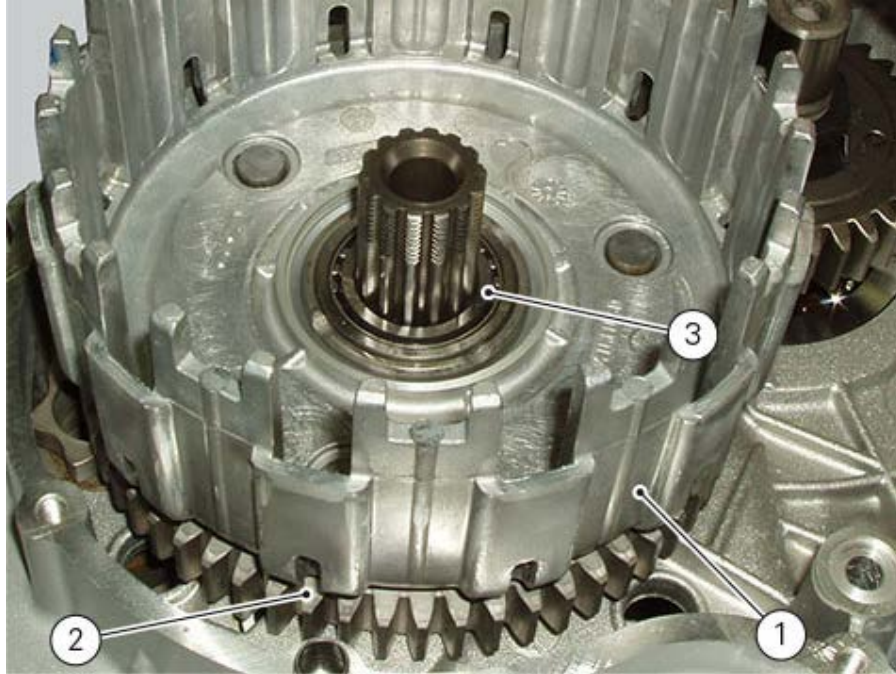

Remove inner ring (5) and spacer (4).

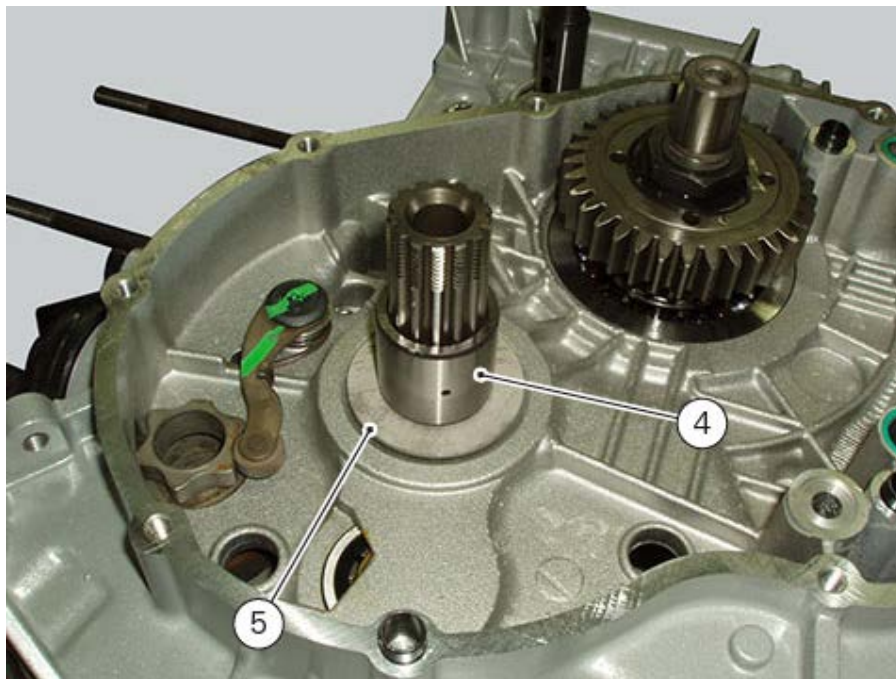

Straighten out lock washer (6) on primary drive driving gear (8) fastening nut (7).

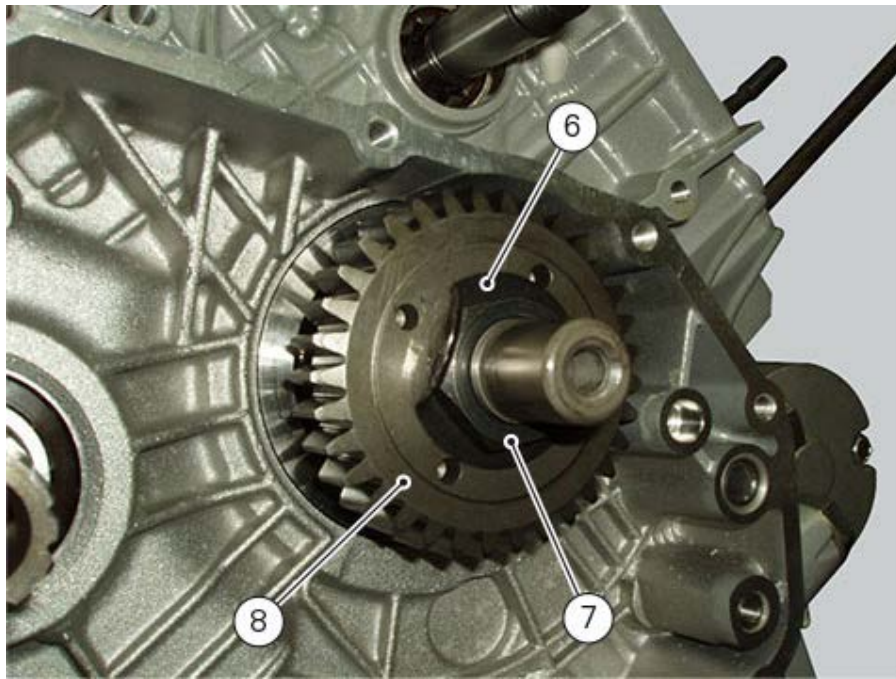

Lock the primary drive gear (8) with holding tool (A) no. **88713.2423** and loosen sprocket threaded ring nut (7).



Remove the nut (7) and the lockwasher (6).

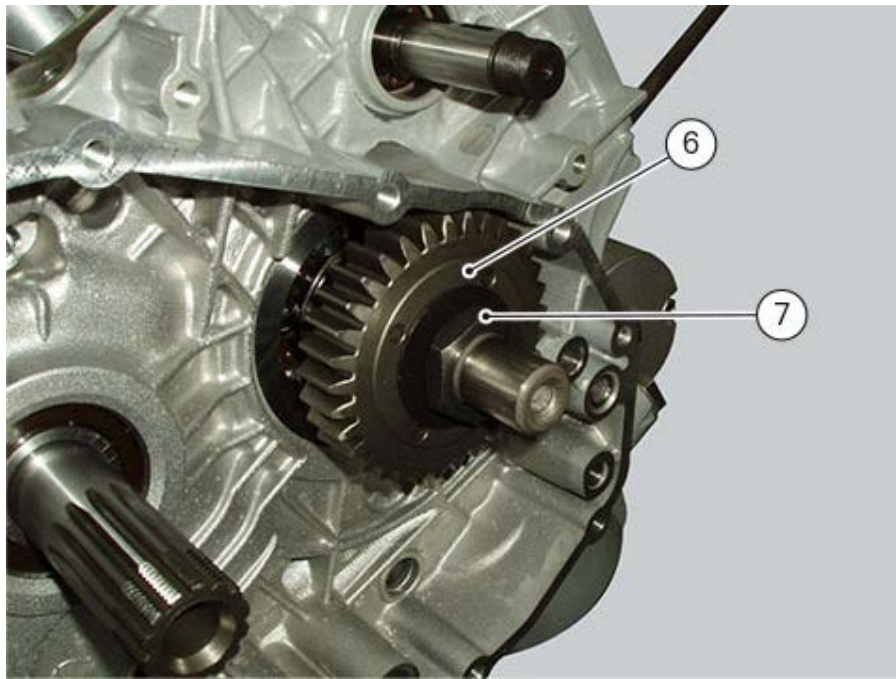

Remove the primary drive driving gear (8) using puller (B) no. **88713.2092** and place between crankshaft and puller screw an aluminium or brass pad.



Pay attention to tab (9) positioned on the crankshaft and to the internal spacer.

Refitting the gearchange mechanism

Position the gearbox drum selector fork in the centre of the gear rollers.

Position the complete gearchange mechanism (3) in the chain-side crankcase half.

Insert the screws (1) and (2) with the spacer (4).

Temporarily fit gearchange lever (or a service lever) and sprocket and shift to neutral gear.

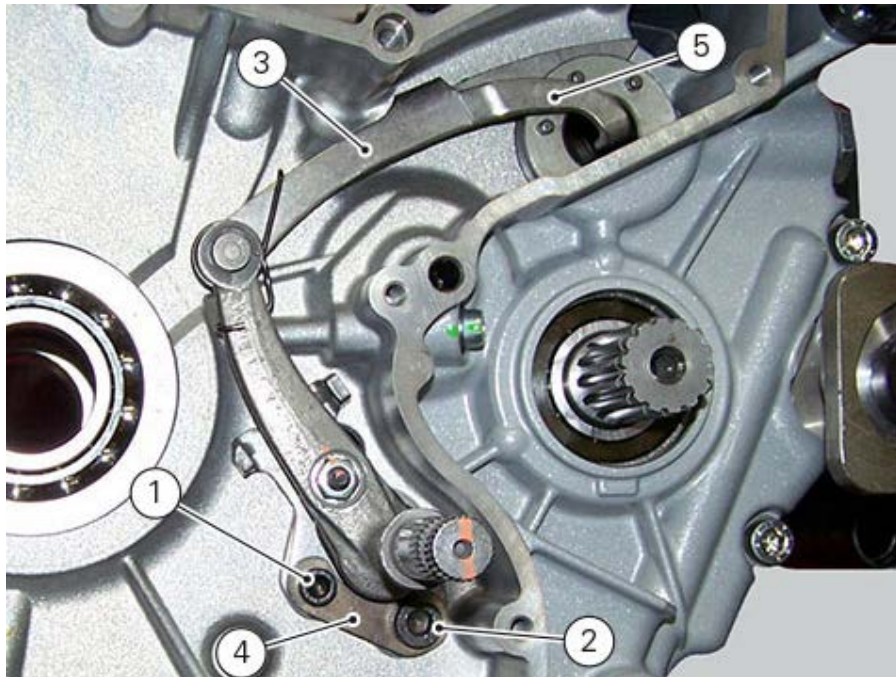

Set tool (A) part no. **88713.3334** on the gearbox pawl.

Position the tool by inserting the engine pin (25) inside the tool hole; engage tool pin (26) in the gearbox pawl by pressing with your hand in the indicated point.

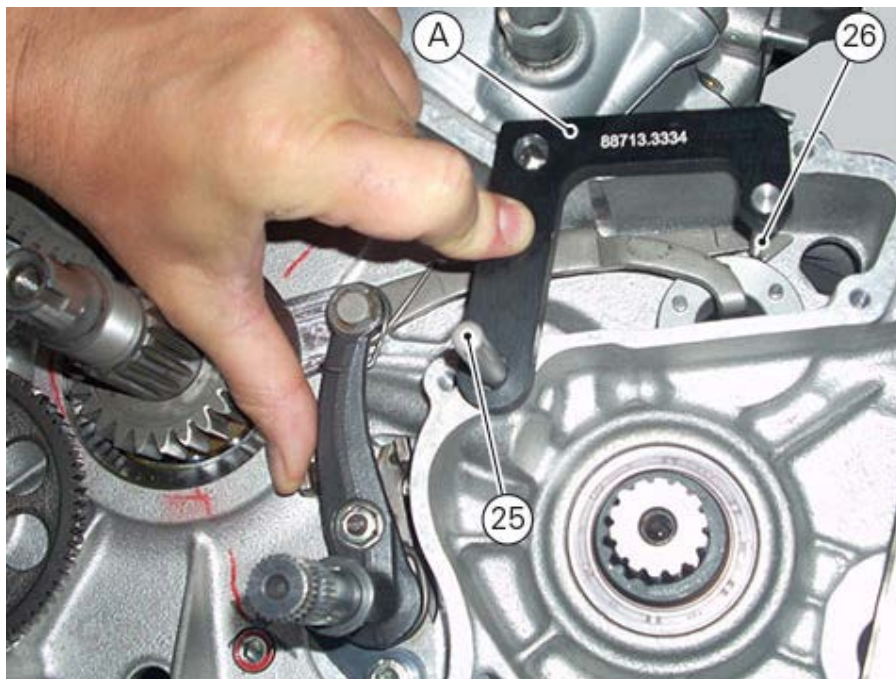

In this position first tighten the screw (2) to a torque of 36 Nm (Min. 34 Nm - Max. 38 Nm) and then the screw (1) to a torque of 16 Nm (Min. 15 Nm - Max. 17 Nm).

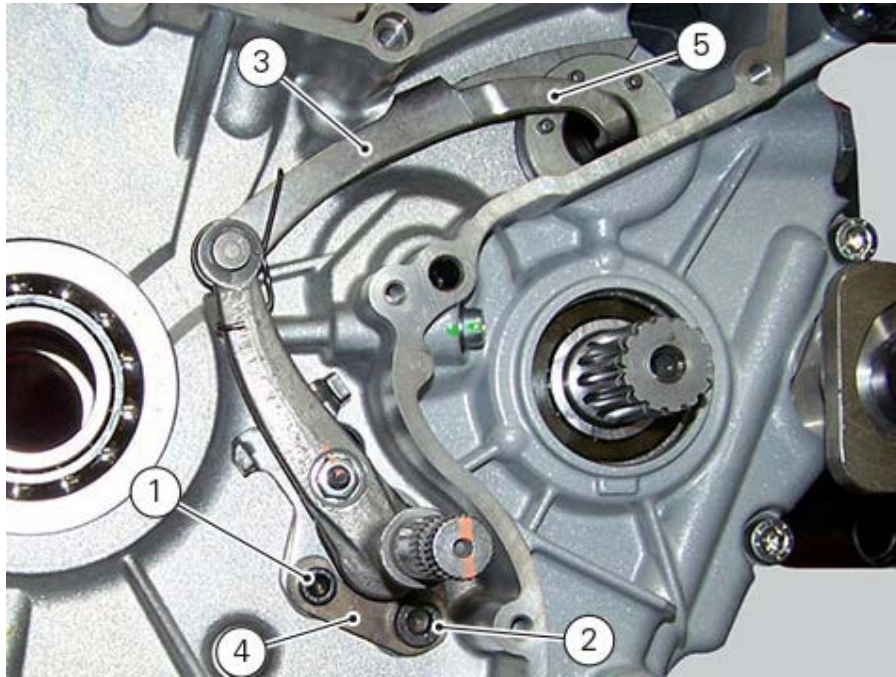

Remove the tool and check that pin (28) on the gearbox drum is aligned with notch (29) on the gearchange pawl.
 With the gearbox in neutral, check that the lever travel is the same when shifting up and down.
 The same should apply when a gear is engaged.
 Operate the gearchange lever and turn the front sprocket at the same time to check that all the gears engage when shifting up and down.
 Remove the gearchange lever.

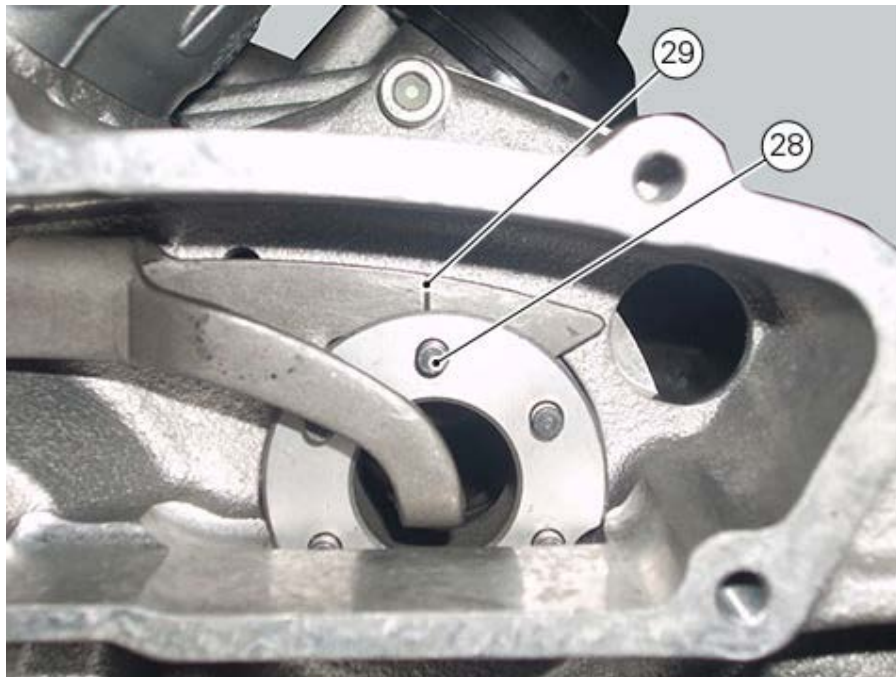

Reassembling the gearchange mechanism

If during the removal procedure the gearchange mechanism has been removed, it is necessary to engage the spring (10) on shaft (12) in the position indicated in the picture.
 Use the specified product to grease the threaded end of the eccentric pin (12) and fit it from the upper side of the gearchange lever and fix it with nut (13).
 Screw the nut fully home (without tightening).

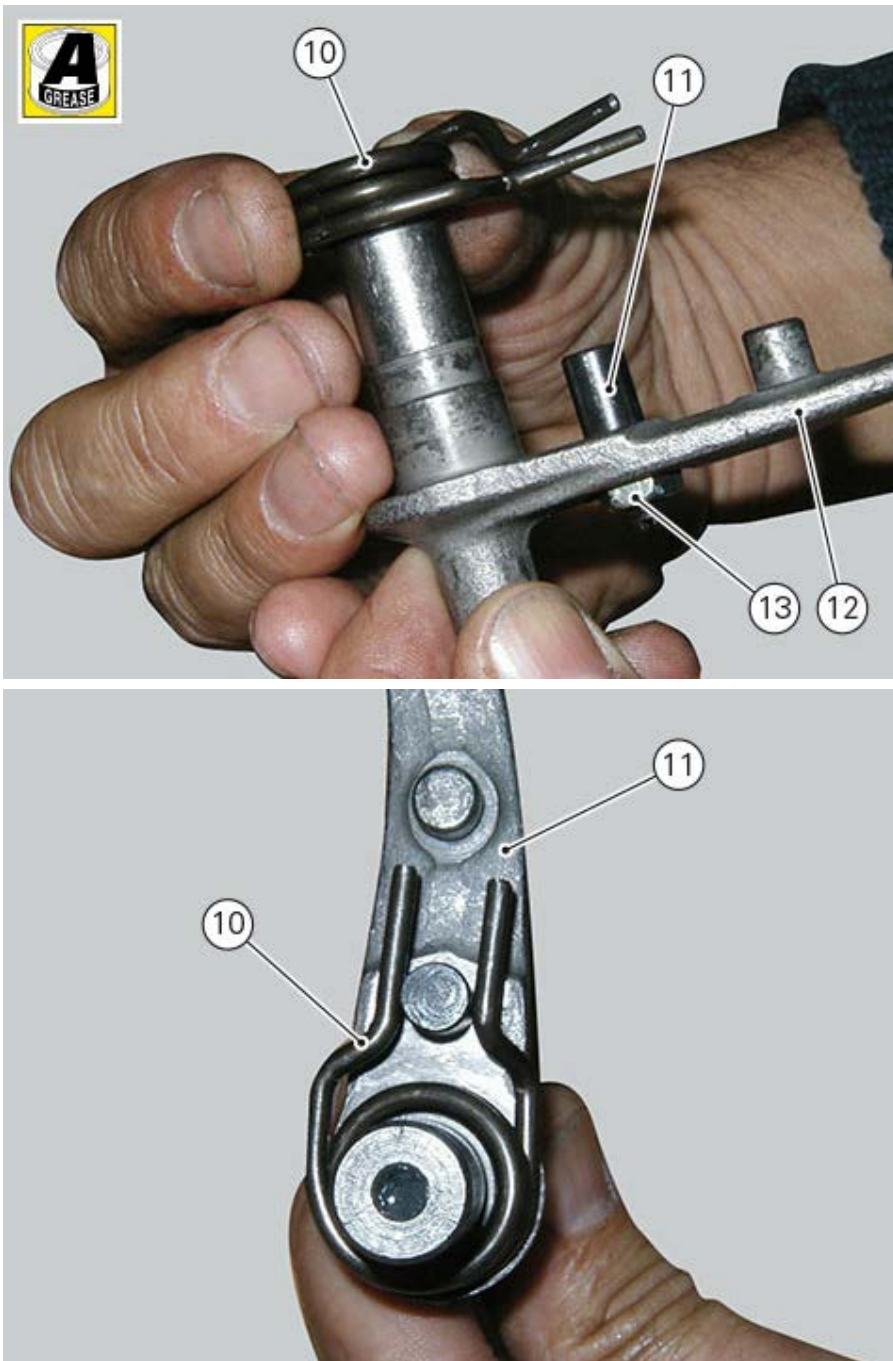

Insert shaft (12) in plate (9), position washer (7) and block with the snap ring (6).

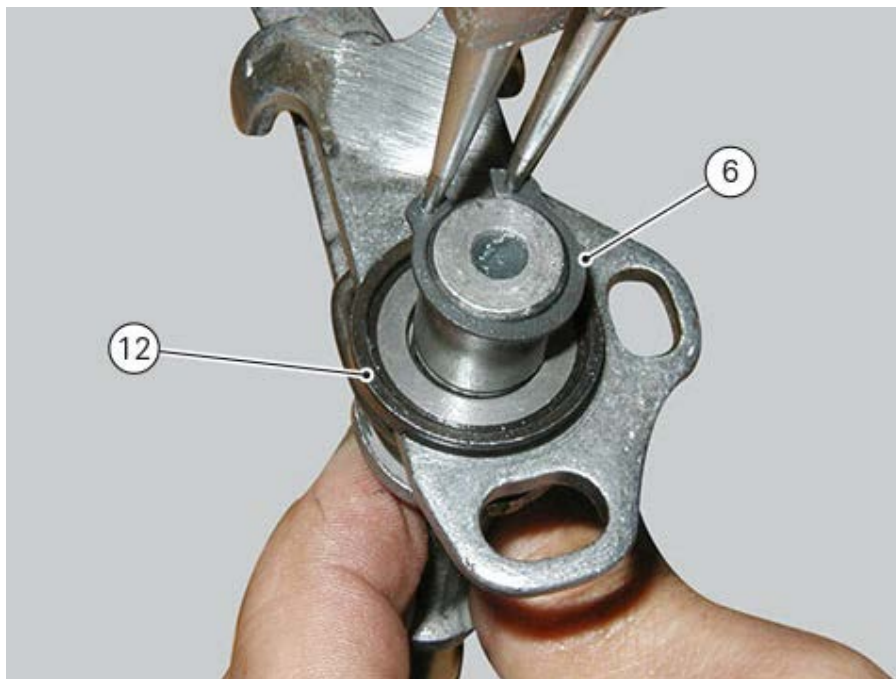
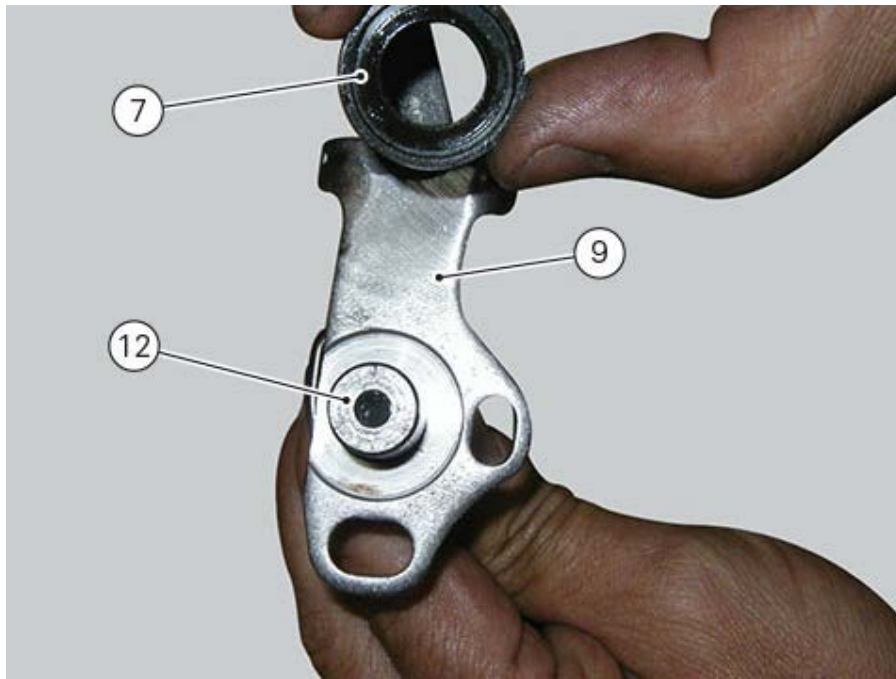

Position lever (12) correctly according to the plate (9) position.
The lever pin must be equidistant from the plate edges; to modify its position, work on the suitable eccentric pin (11) after loosening lock nut (13).

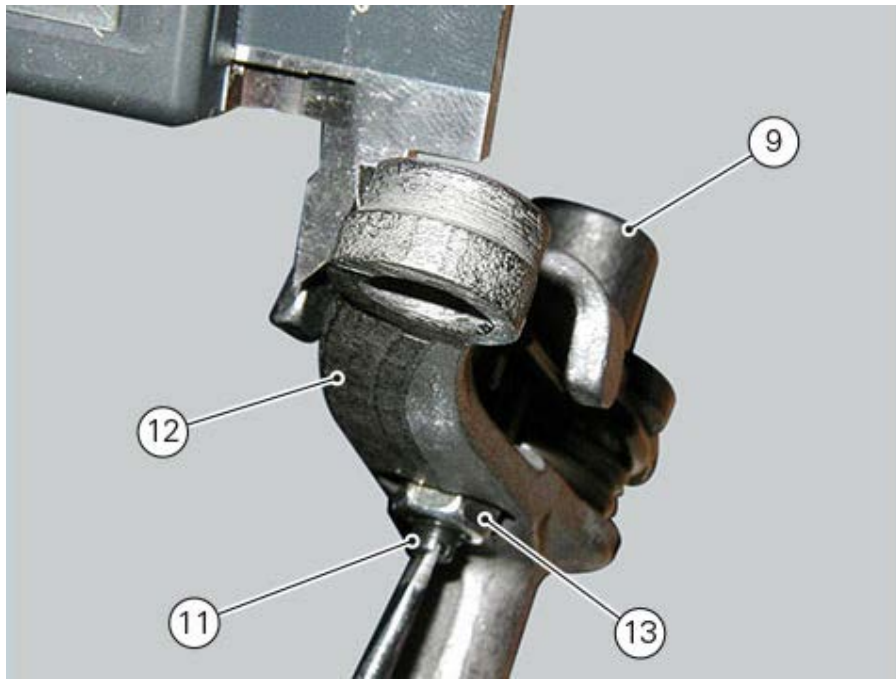

Position spring (16) between shaft (12) and fork (5).
Fit ring (14) to block the coupled elements.
Check that the spring (16) is installed correctly as shown in the figure.
Then tighten nut (13) to a torque of 10 Nm (Min. 9 Nm - Max. 11 Nm)

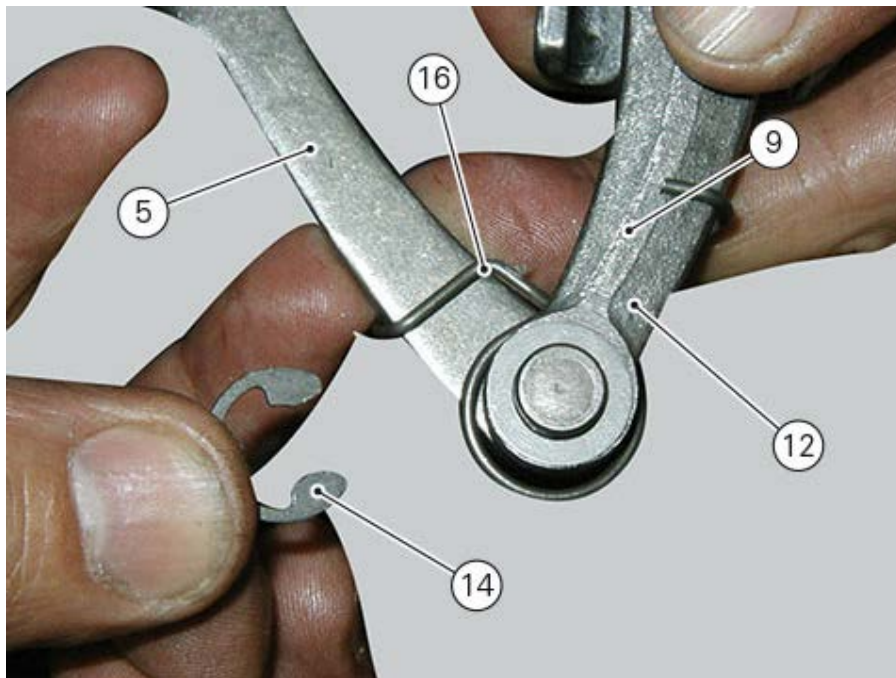

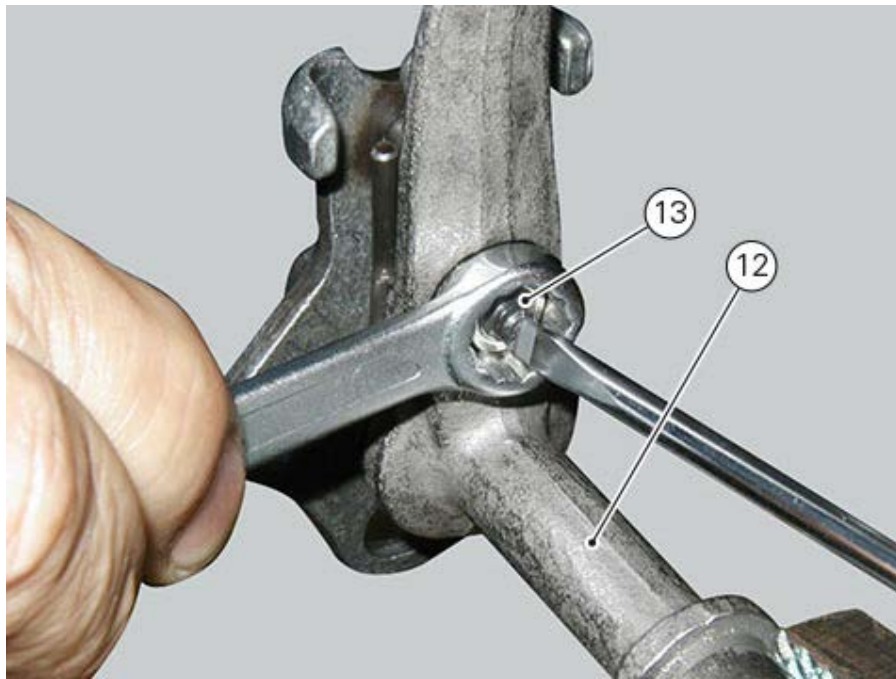

Refit the flywheel/generator assembly and the generator cover ([Refitting the flywheel/generator assembly](#)).

Refit the gear shift ([Refitting the gear shift](#)).

Refit the front sprocket ([Refitting the front sprocket](#)).

Fill with engine oil ([Changing the engine oil and filter cartridge](#)).

Refitting the gear interlock plunger and ratchet

On the retaining screw (21), fit the gear ratchet (22), orienting it as shown in the figure, the washer (23) with the sharp edge side facing the clutch-side crankcase half, and the spring (24), positioning it so that the hook end is facing the gear ratchet.

Apply threadlocker on screw thread.

Start the screw in the crankcase half. Position spring end against the crankcase half rib.

Tighten screw (21) to a torque of 18 Nm (Min. 16 Nm - Max. 20 Nm).

Manually move the gear ratchet to check for proper spring operation.

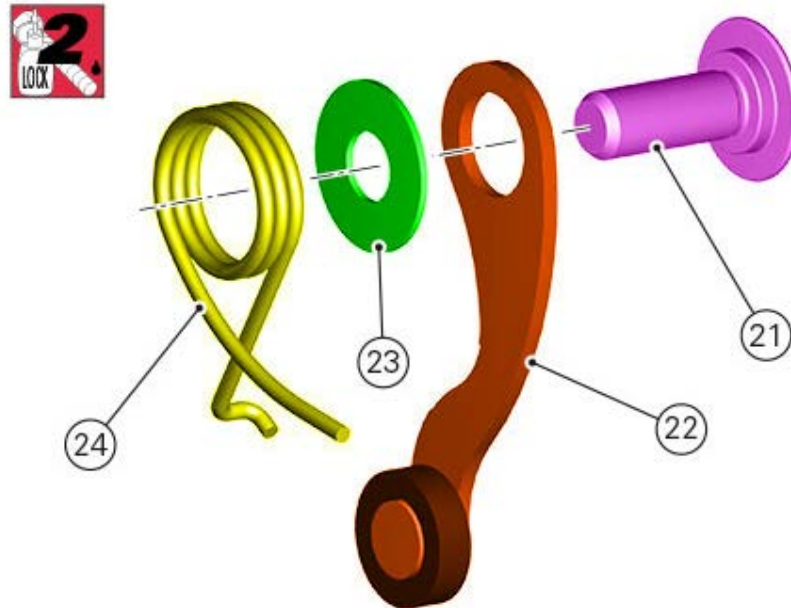

Grease and then fit the ball (20), spring (19) and seal (18) to the gear interlock plunger (17) and screw the plunger on the casing.

Tighten the gear interlock plunger to a torque of 30 Nm (Min. 27 Nm - Max. 33 Nm)



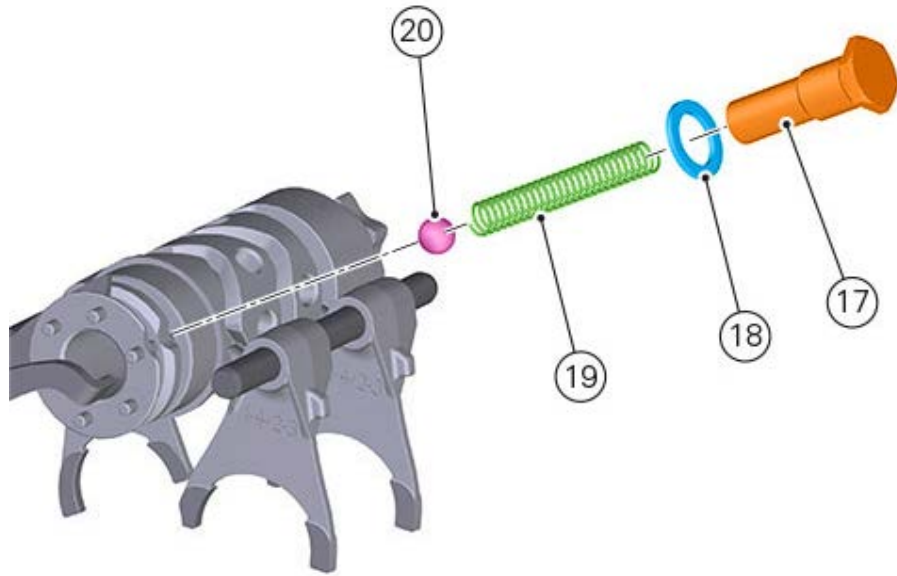

Refit the clutch unit ([Refitting the clutch](#)).

Reconnect the oil pressure sensor.

Fill the engine with oil ([Changing the engine oil and filter cartridge](#)).

Disassembling gear interlock plunger and ratchet

Drain the engine oil ([Changing the engine oil and filter cartridge](#)).

Disconnect the oil pressure sensor.

Remove the clutch cover ([Removing the clutch cover](#)).

Remove the clutch unit ([Removing the clutch](#)).

Undo the interlock plunger screw (17) and remove the seal (18), the spring (19) and the ball (20).

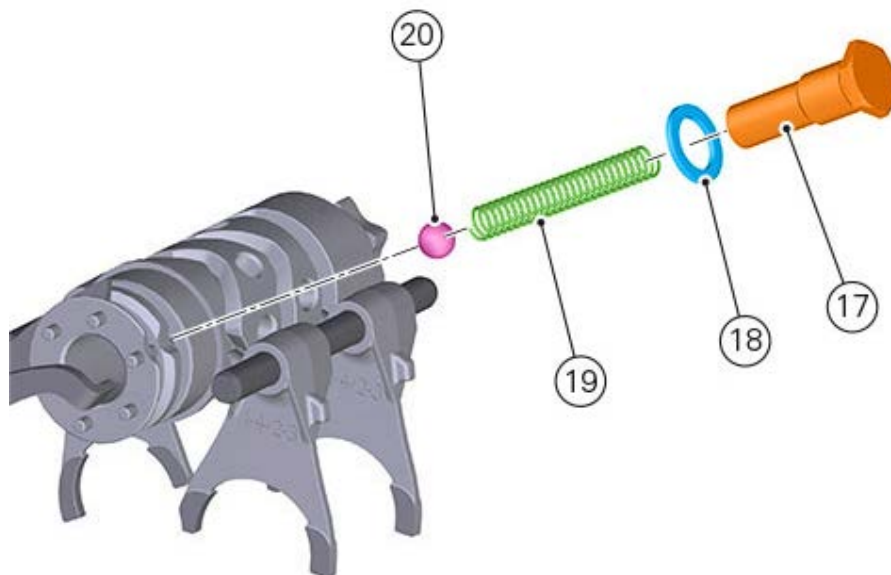

Undo the clutch-side crankcase half screw (21) and remove the ratchet (22), the washer and the spring.

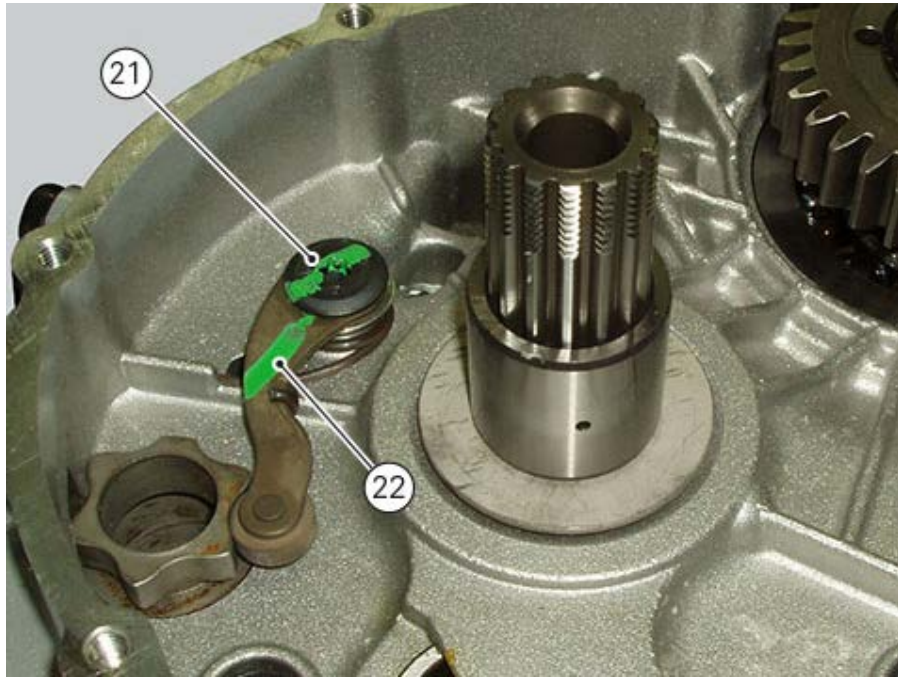

Removing the gearchange mechanism

Drain the engine oil ([Changing the engine oil and filter cartridge](#)).

Remove the gear shift ([Removing the gear shift](#)).

Remove the front sprocket ([Removing the front sprocket](#)).

Remove the generator cover ([Removing the generator cover](#)).

Undo the fixing screws (1) and (2) of the complete gearchange mechanism (3).

Remove screws (1) and (2), plate (4) and slide out the gearchange mechanism with control shaft, spring and plate.

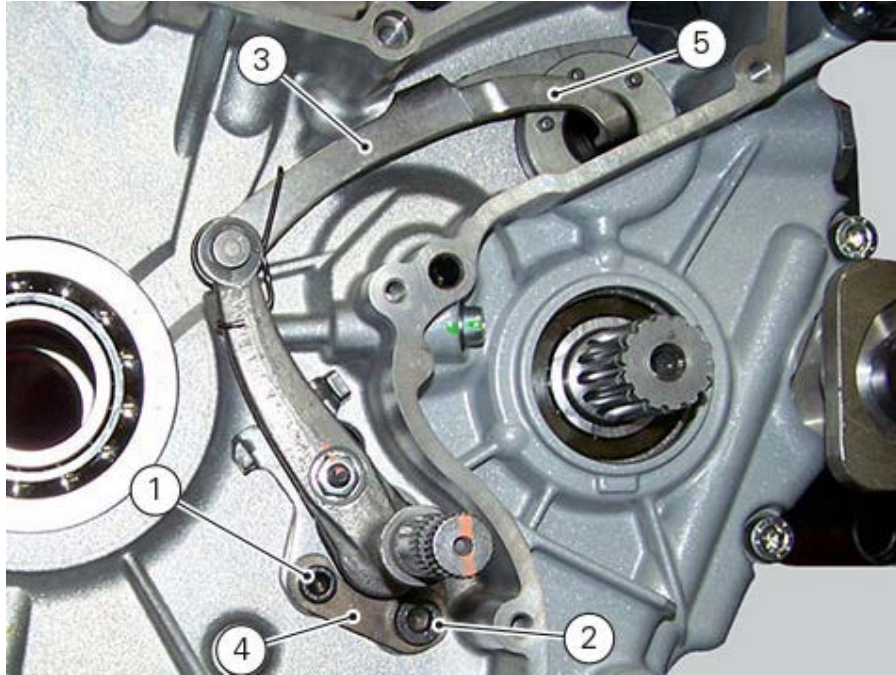

Disassembling the gearchange mechanism

If it proves necessary to change components, disassemble the gearchange mechanism as shown in the picture.

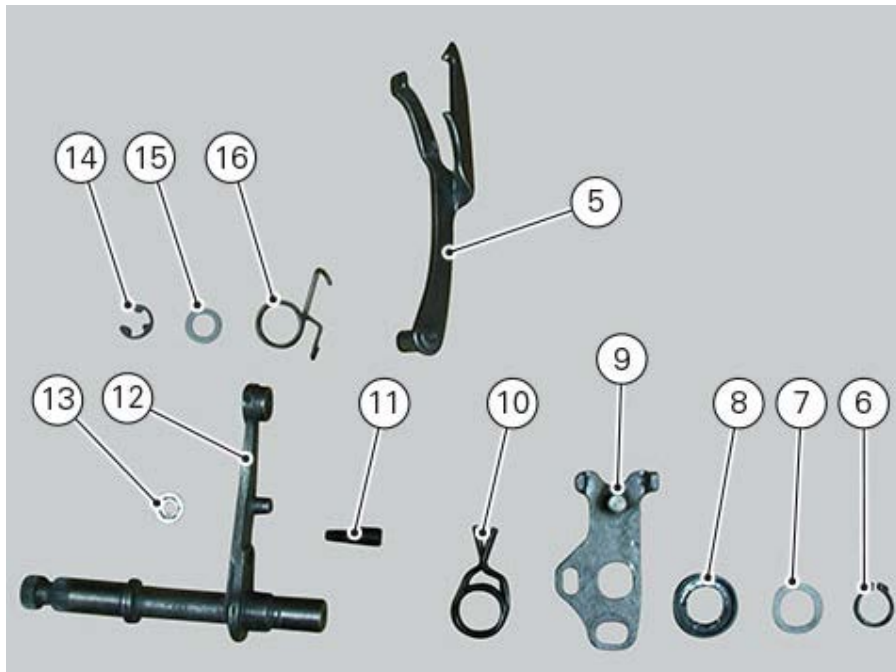

Reassembling the gearbox assembly

To refit the gearbox components follow the procedure under chapter "[Closing the crankcase](#)" relating to the reassembly of the crankcase.

As a final practical test, ensure that with the gearbox in neutral the front coupling dogs (A) of sliding gears (B) are equidistant on both sides with respect to the corresponding coupling dogs on the fixed gears (C). Check also that there is always a small amount of clearance between fork (D) and relative groove (E) on sliding gear (B) when engaging the gears.

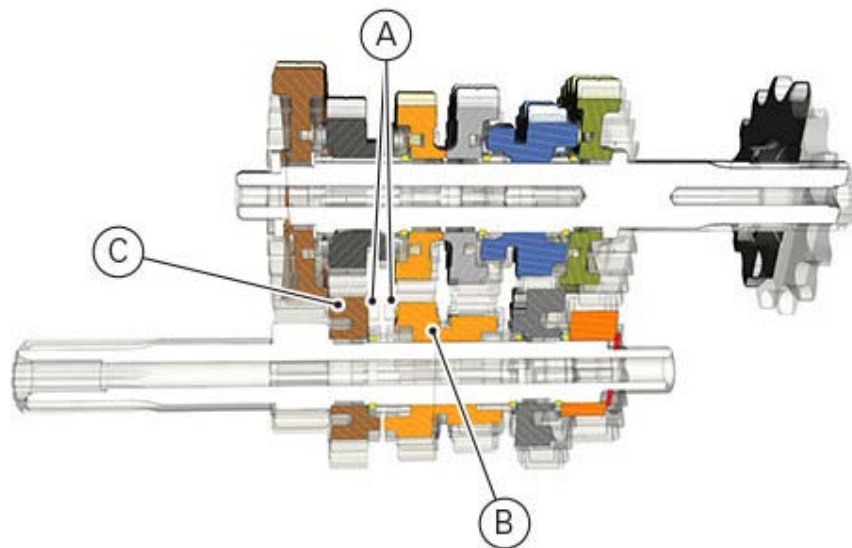
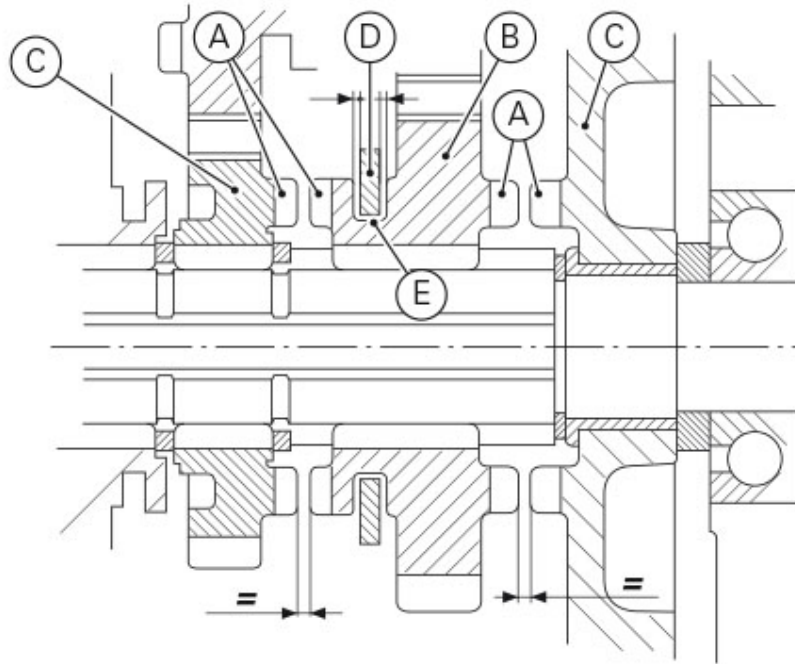

Refit the engine in the frame ([Refitting the engine](#)).

Reassembling the gearbox shafts

Reassemble the gears on the gearbox shafts by reversing the disassembly procedure.

Take particular care when installing the idler gears.

The assembly of the 3rd and 4th speed gears and the relative fixing components on the secondary shaft is given as an example.

Fit the snap ring (17), checking that it is fully inserted into its groove on the shaft.

Push the snap ring into position with a suitable size tubular drift.

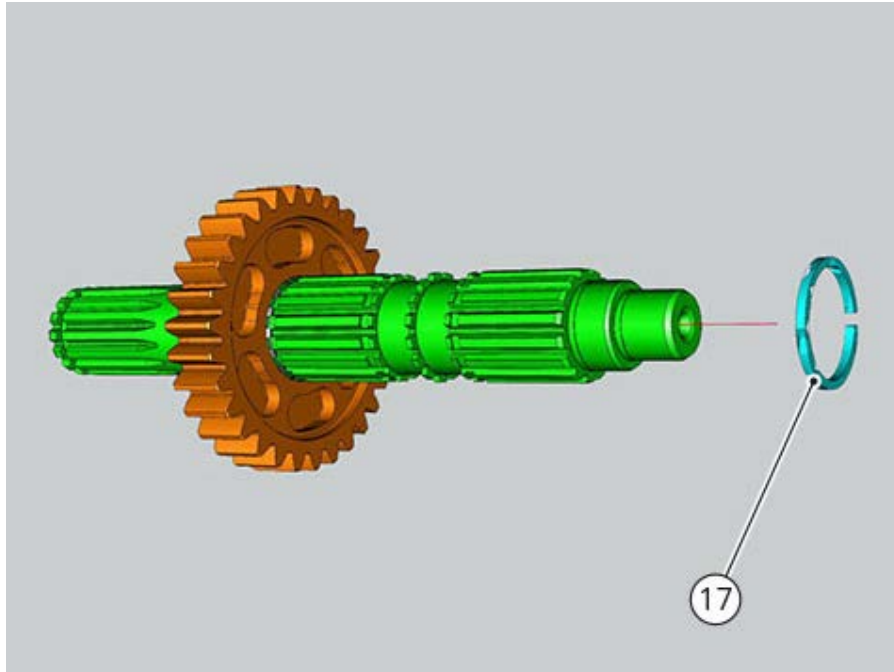

Slide the three-pointed washer (18) over the shaft until it locates against the snap ring you have just fitted.

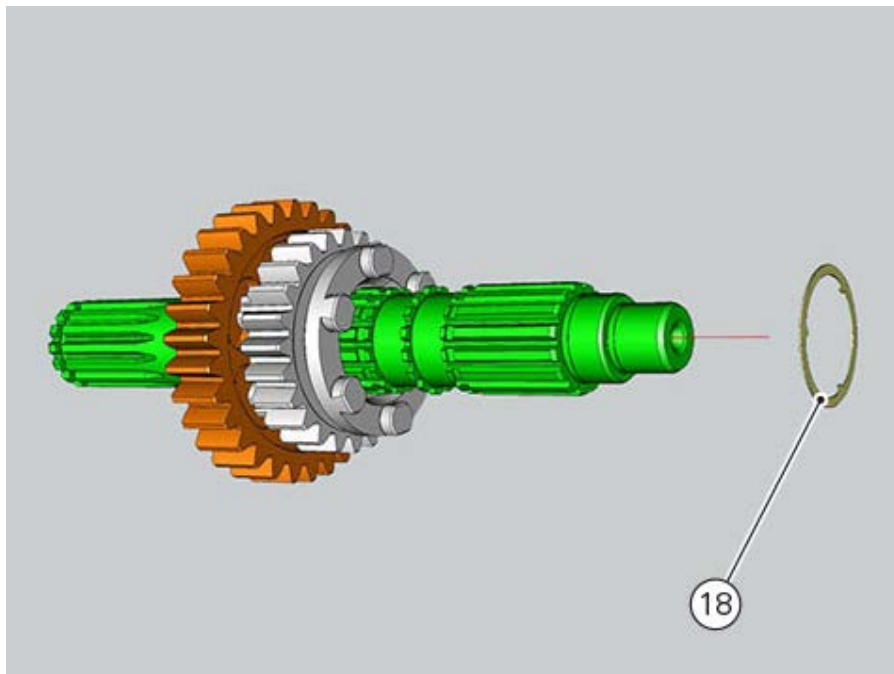

To fit the roller bearing cage (21) onto the shaft, first lubricate it with plenty of grease (of recommended type) and then open it slightly to make it easier to slide on to the shaft.

Fit the 3rd speed gear (22).

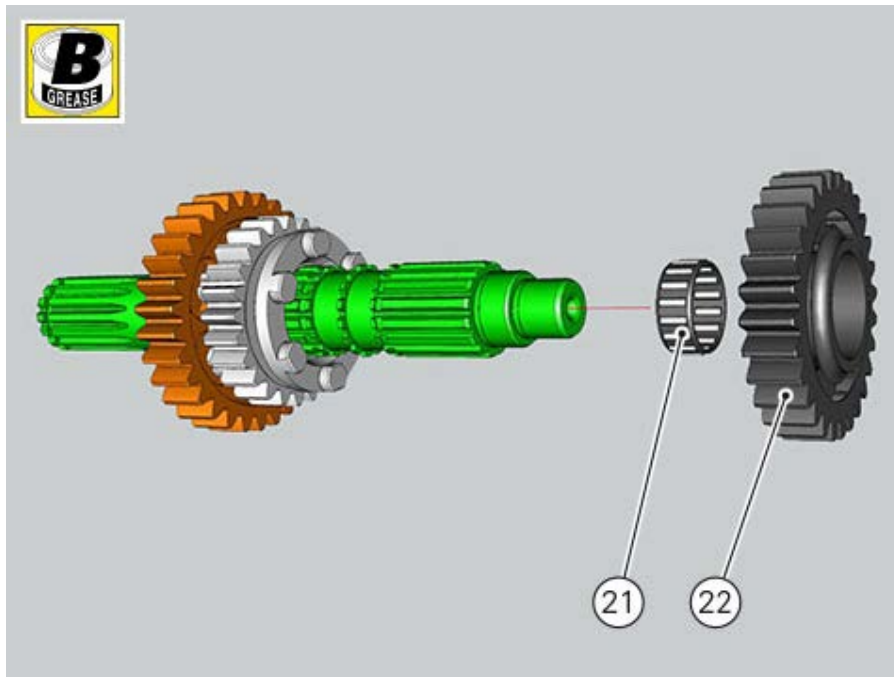

Fit the three-pointed washer (21), which has a bigger outer diameter than the other one (18), in the gear.

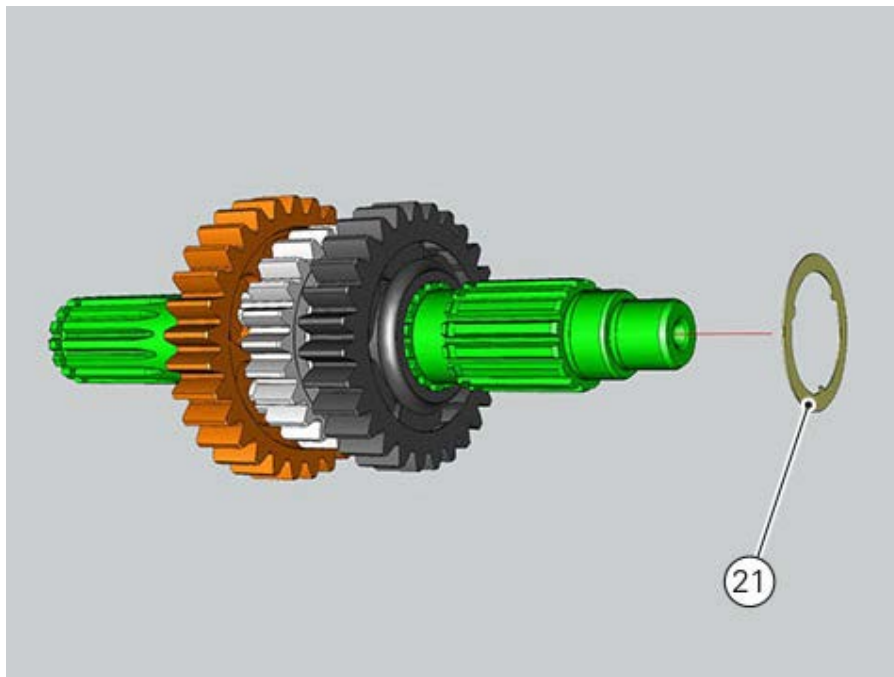

Fit another roller bearing cage (20) using the method already described.
Fit the 4th speed gear (19).

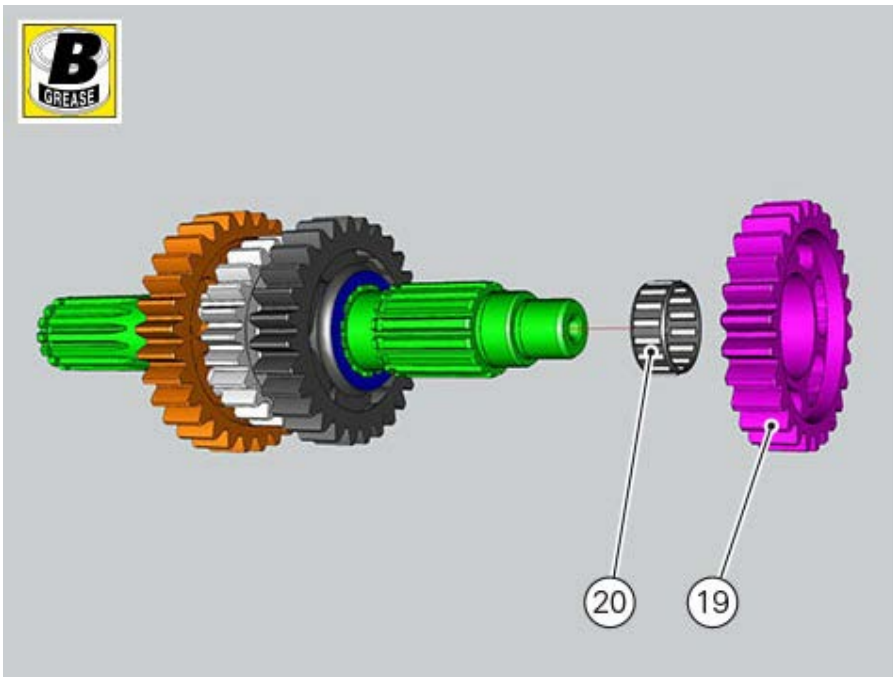

Fit another three-pointed washer (18) and another snap ring (17) into the shaft. Push it inside its seat using the previously used drift.

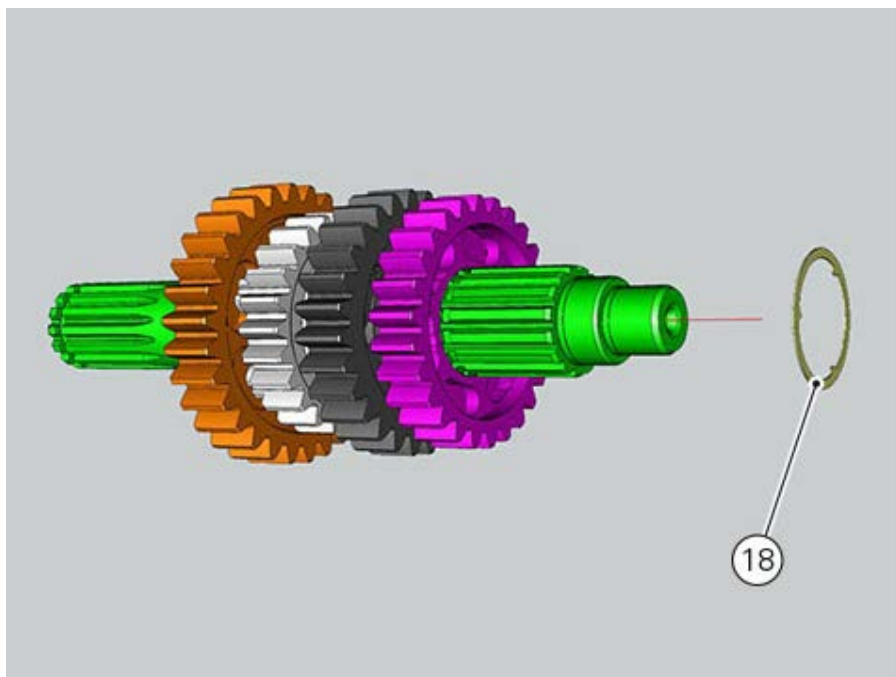

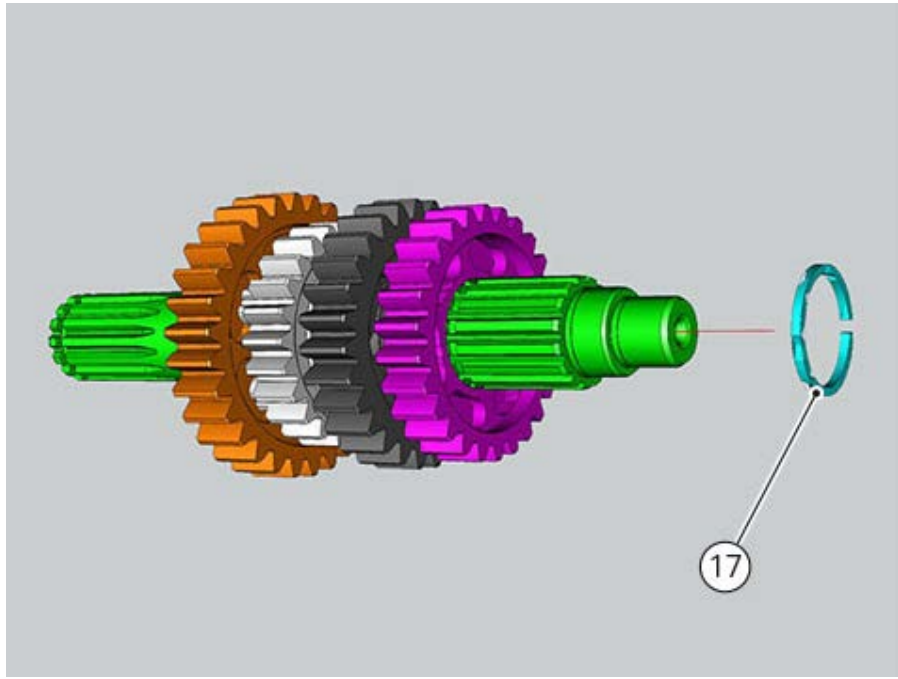

Inspecting the fork selector drum

Use a gauge to measure the clearance between fork pin and the groove on the selector drum.
If the service limit has been exceeded, determine which part must be replaced by comparing these dimensions with those of new components.

Also check the wear on the drum support pins; these must not show any signs of scoring, burrs, or deformation.

Turn the drum in the crankcase to establish the extent of radial play.

If play is excessive, change whichever part is most worn.

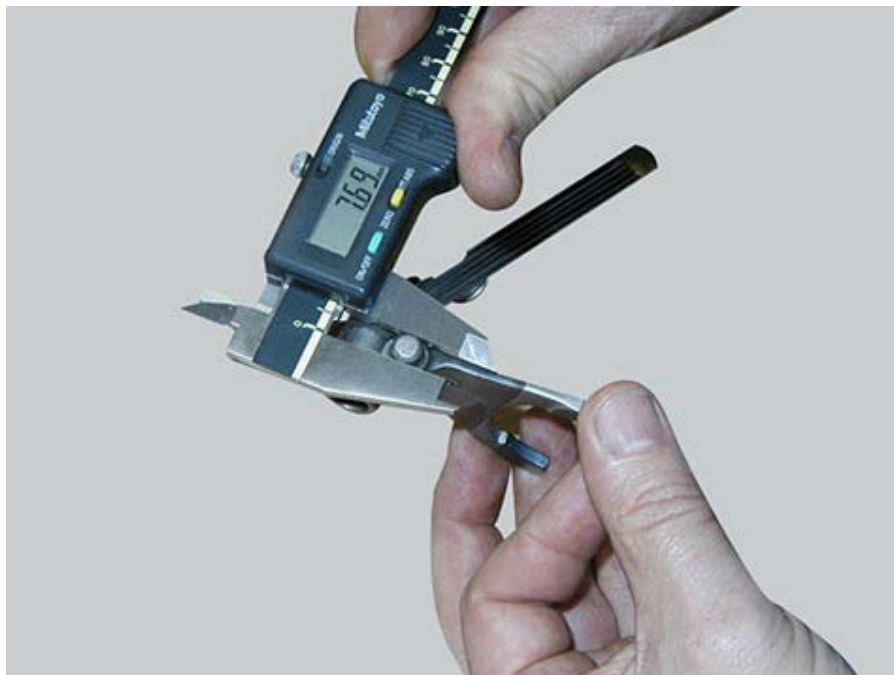

Inspecting the gear selector forks

Visually inspect the gear selector forks. Bent forks must be replaced as they may lead to difficulties in gear changing or may suddenly disengage when under load.

Use a feeler gauge to check the clearance of each fork in its gear groove.

If the service limit has been exceeded, check whether or not it is necessary to replace the gear or the fork by referring to the limits specified for each part.

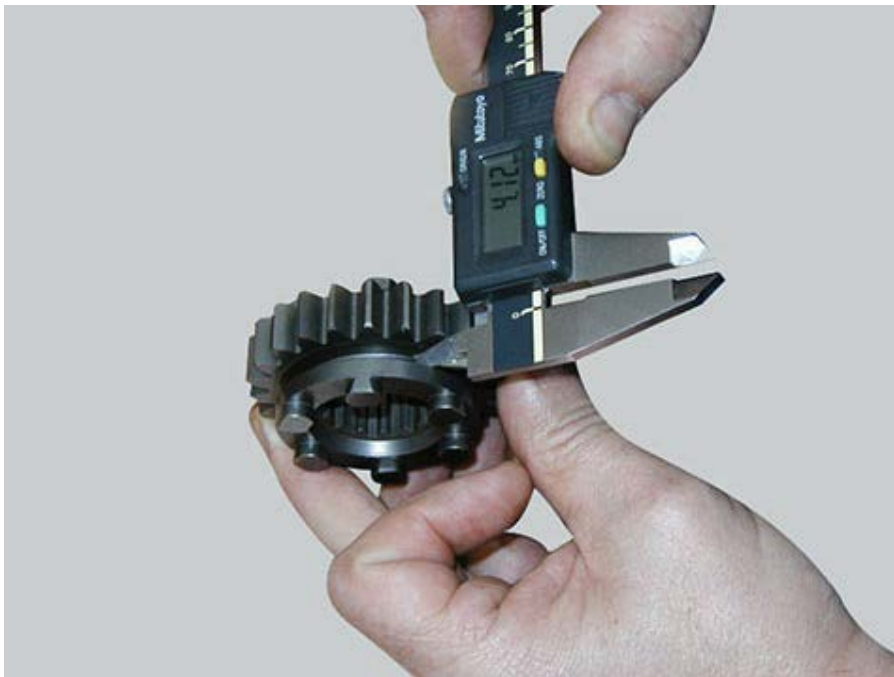
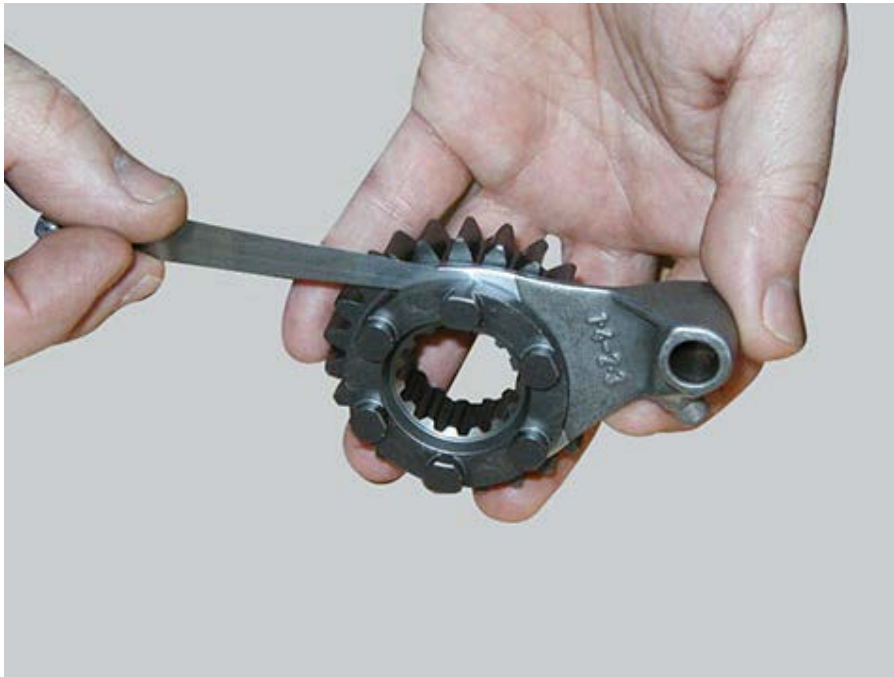



Overhauling the gearbox

Check the condition of the front coupling dogs of the gears. They must be in perfect condition and with no sign of wear on the edges of the teeth.

The idler gears must rotate freely on their shafts.

When refitting, make sure the circlips are correctly positioned.

Check the needle roller bearings for wear.

The threads and splines of the shafts must be in perfect condition.

Also check that the component parts of the gear selector mechanism are in good condition.

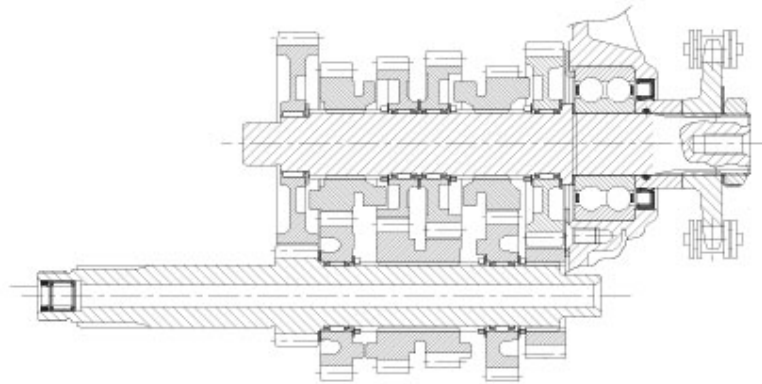

Engage the gears and check that the gearchange mechanism does not stick (selector fork-gear groove, and fork pin-desmodromic drum groove) due to incorrect end float.

Restore the correct end float by shimming the gearbox shafts and the selector drum with suitable shims.

Disassembling the gearbox shafts

Important

Take care not to invert the shim position upon reassembly: this would potentially lead to jamming when using the gear selector control, making it necessary to reopen the crankcase.

Disassembling the gearbox secondary shaft

Remove the chain-side washer (11) and the clutch shim washer (12) from the secondary shaft.



Withdraw the first speed driven gear (13) with the roller cage (14) and the shim (15).

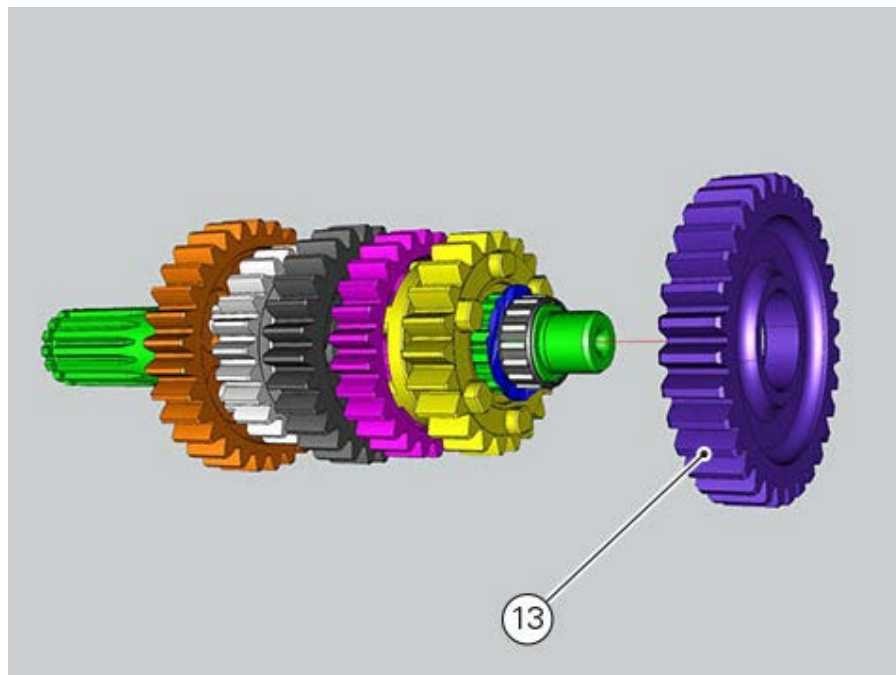

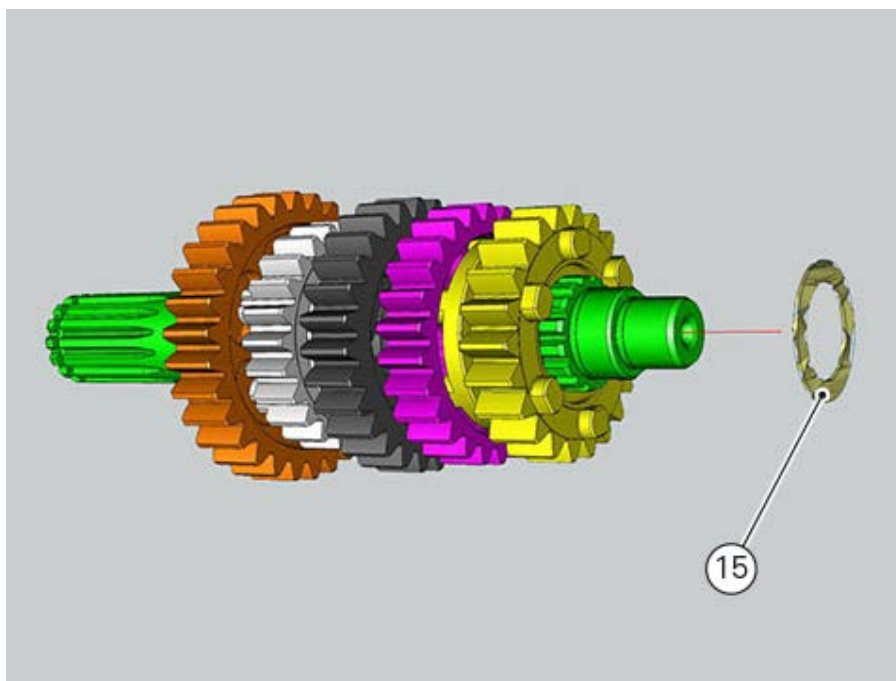
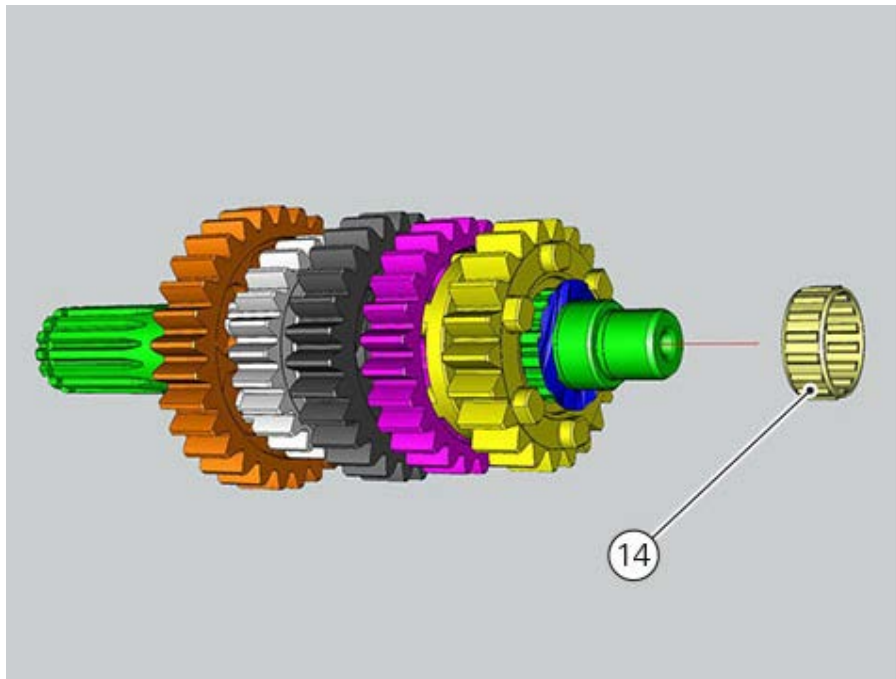

Remove the fifth speed driven gear (16).

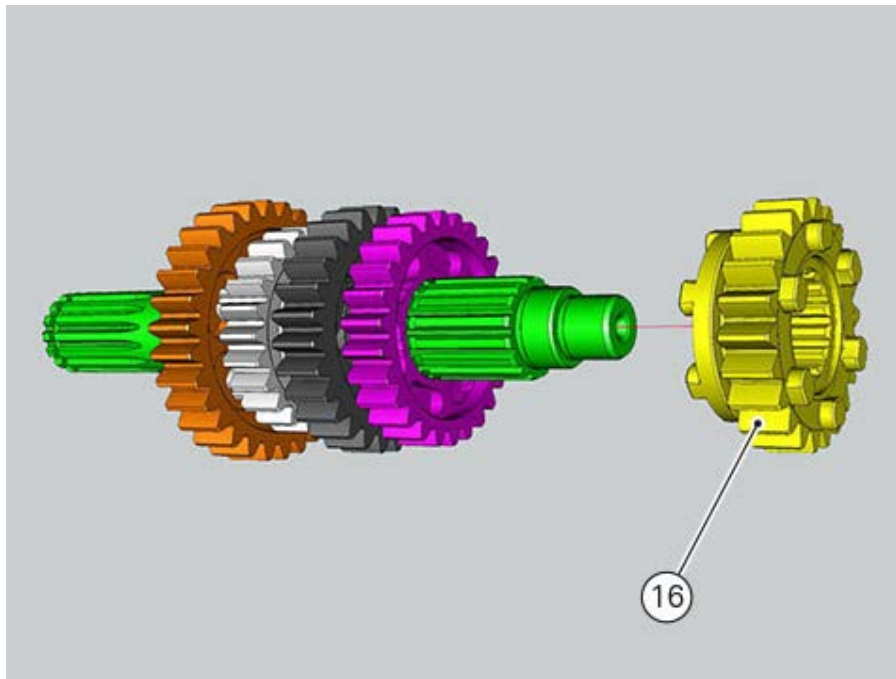

Use two flat blade screwdrivers to remove the snap ring (17) from its seat, taking care not to damage the shaft surface.
Remove the snap ring (17) and the splined washer (18).

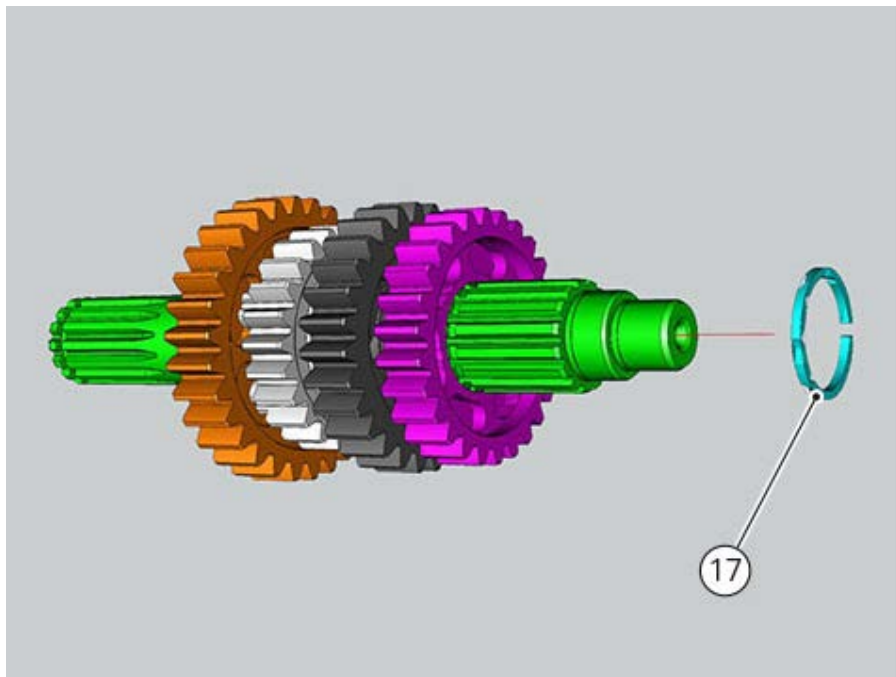

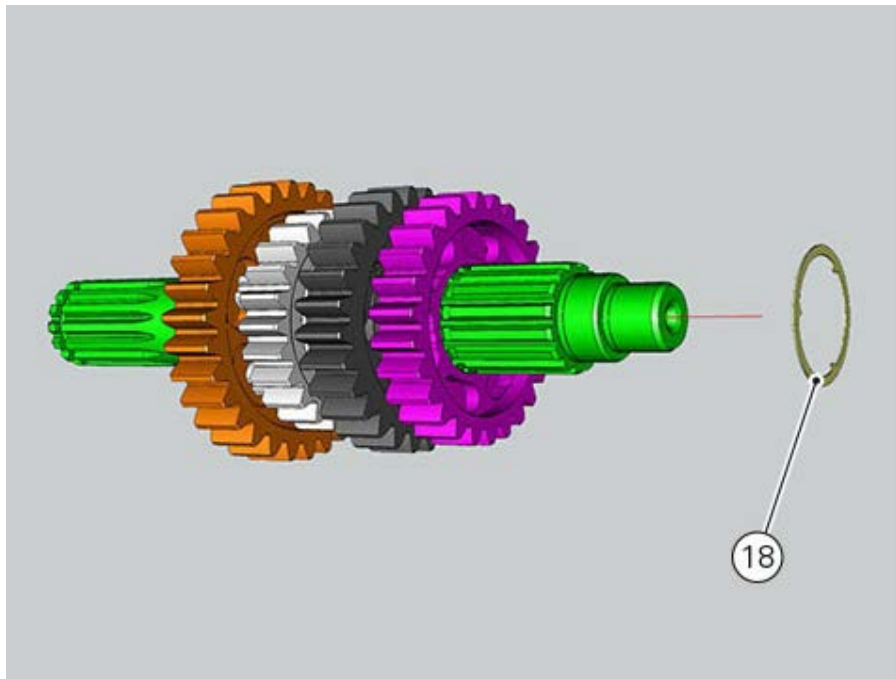

Remove the fourth speed driven gear (19) with its roller bearing cage (20) and splined washer (21).

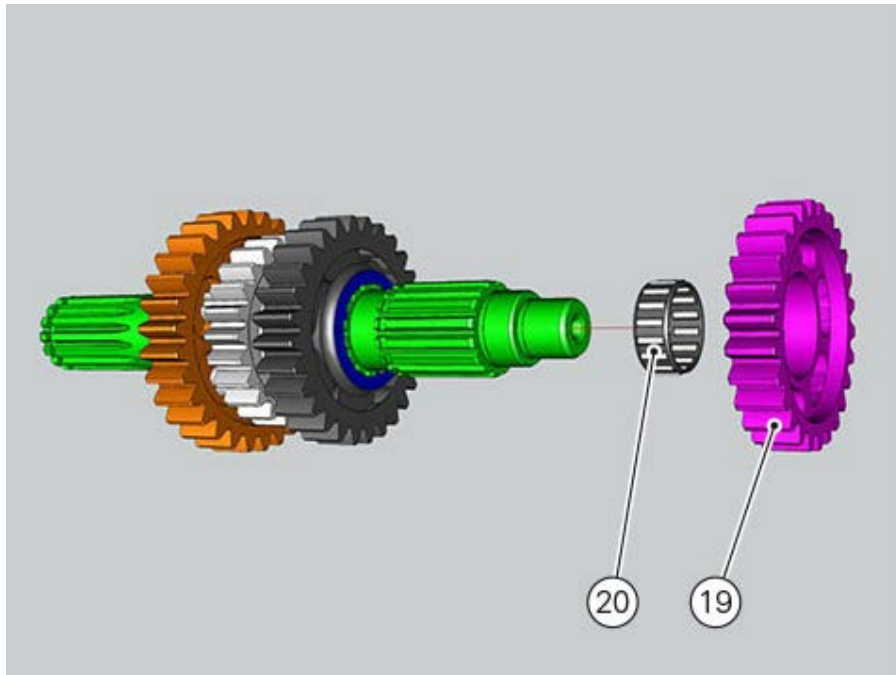

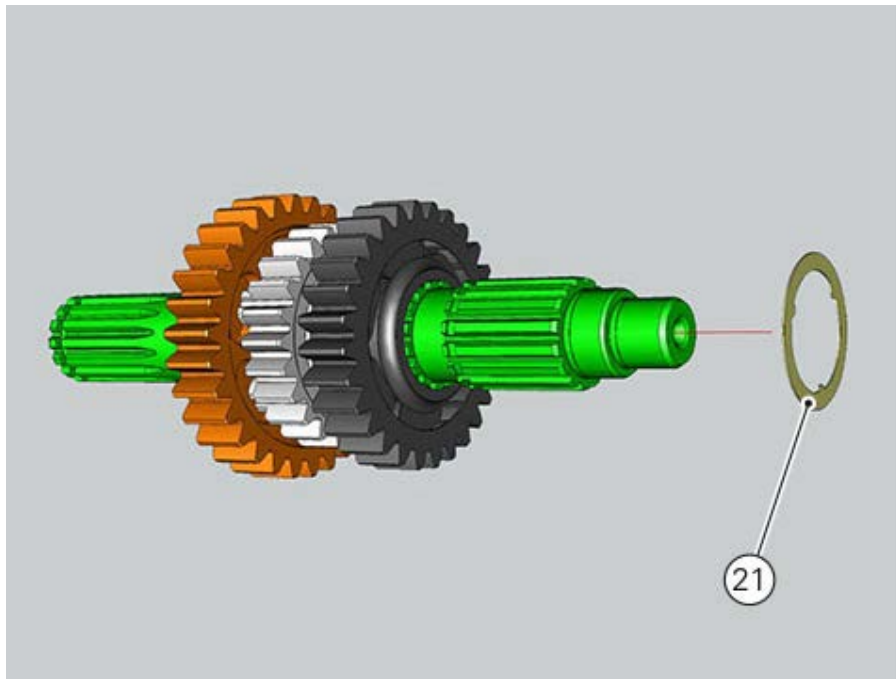

Remove the third speed driven gear (22) with its roller bearing cage (20) and splined washer (18).

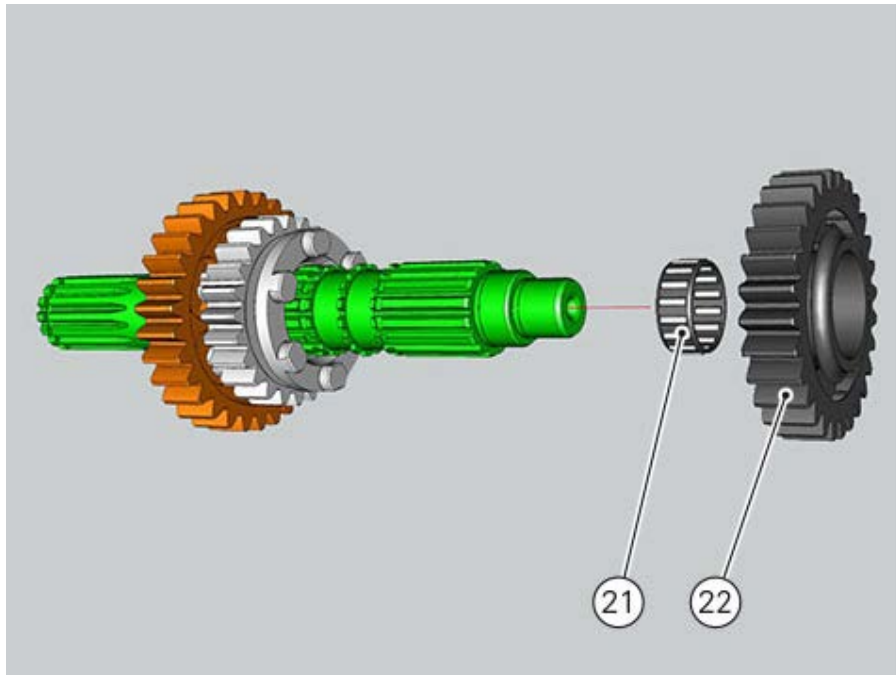

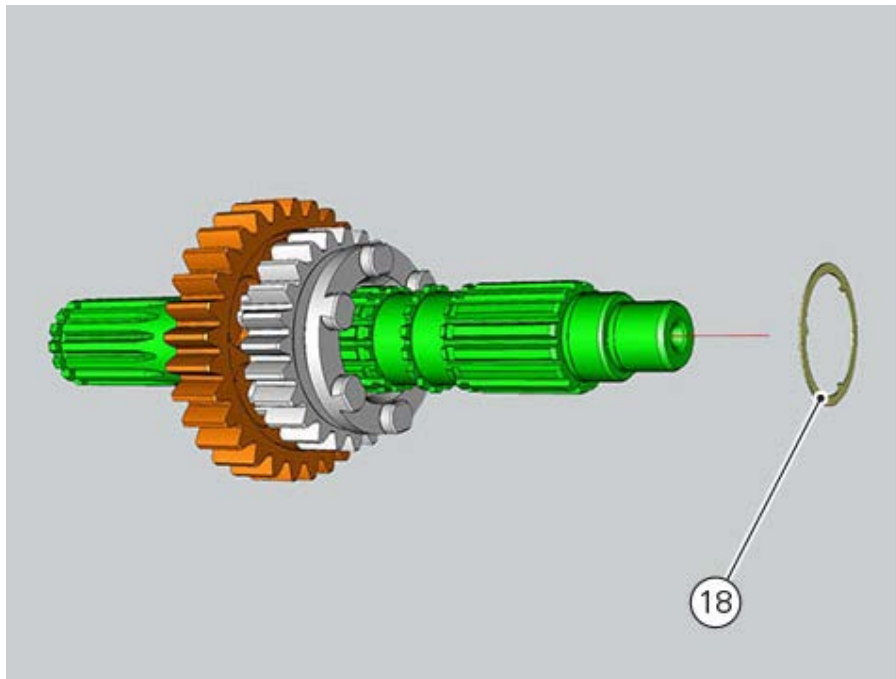

Remove snap ring (17) and slide out the sixth speed driven gear (23).

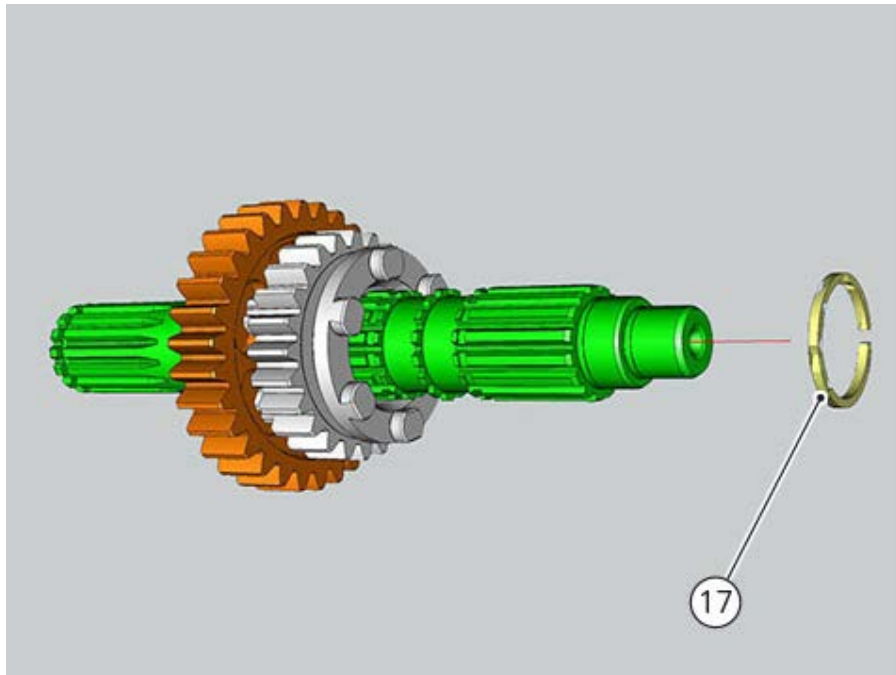

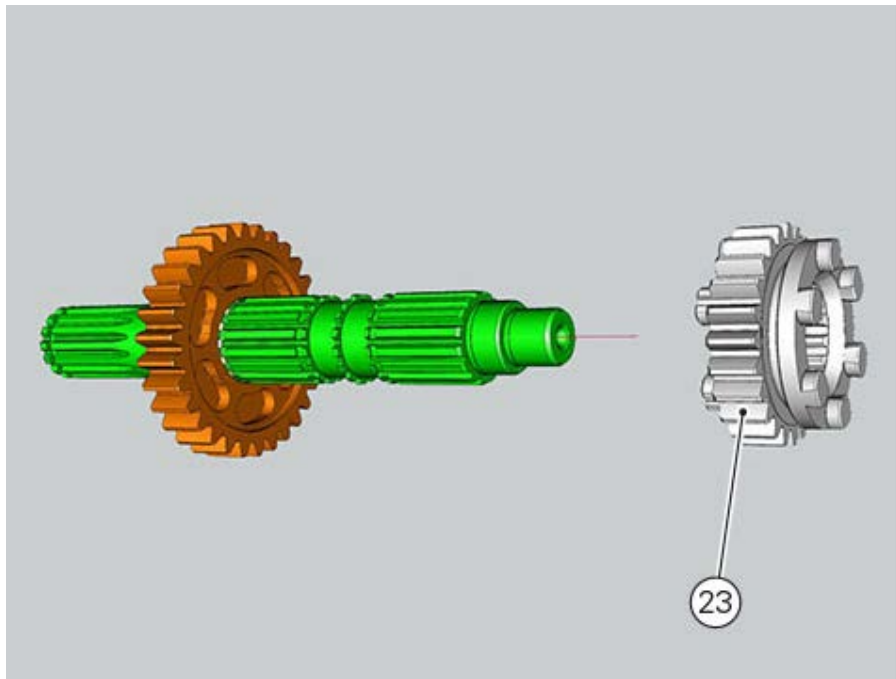

Remove the snap ring (17) and withdraw the splined washer (18) and the second speed driven gear (24).

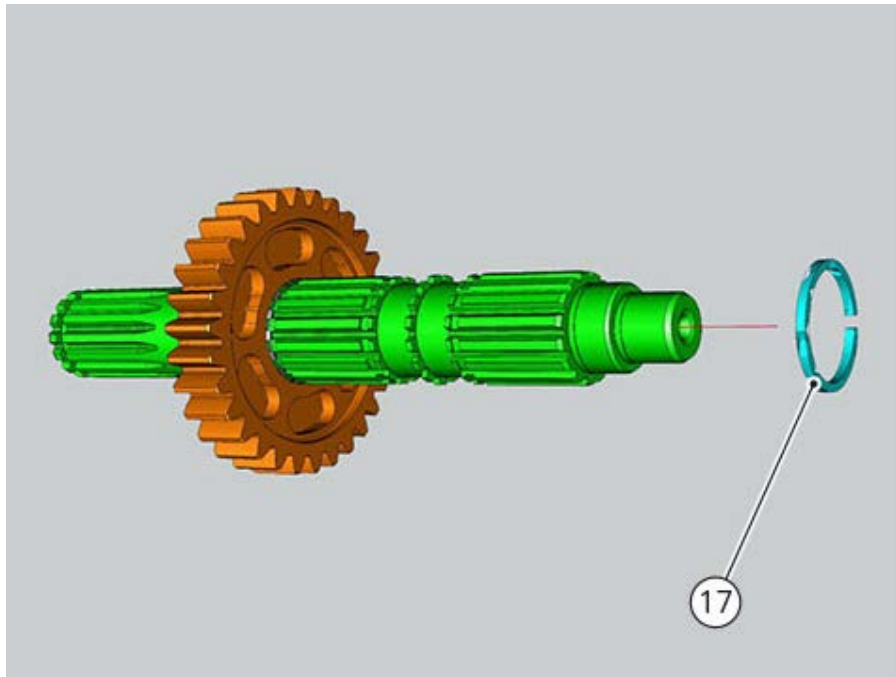

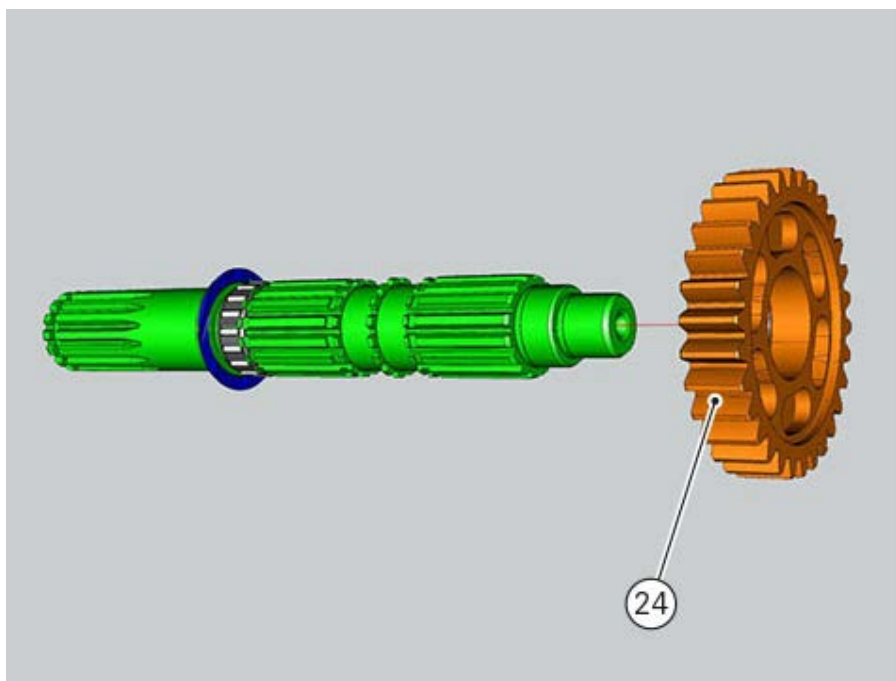
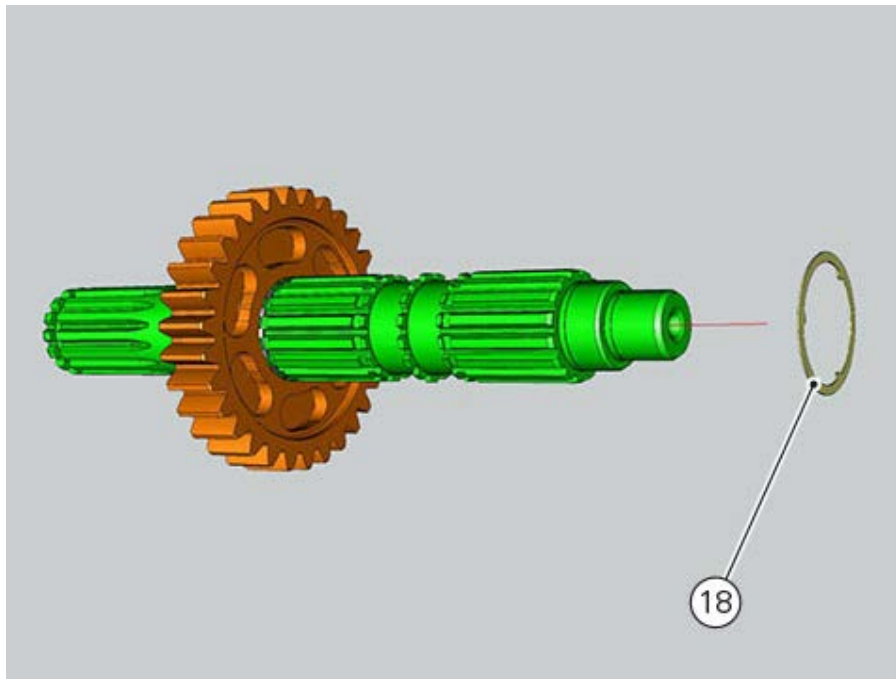

Withdraw the roller bearing cage (20) and the shim (25). All the components have thus been removed from gearbox secondary shaft (10).

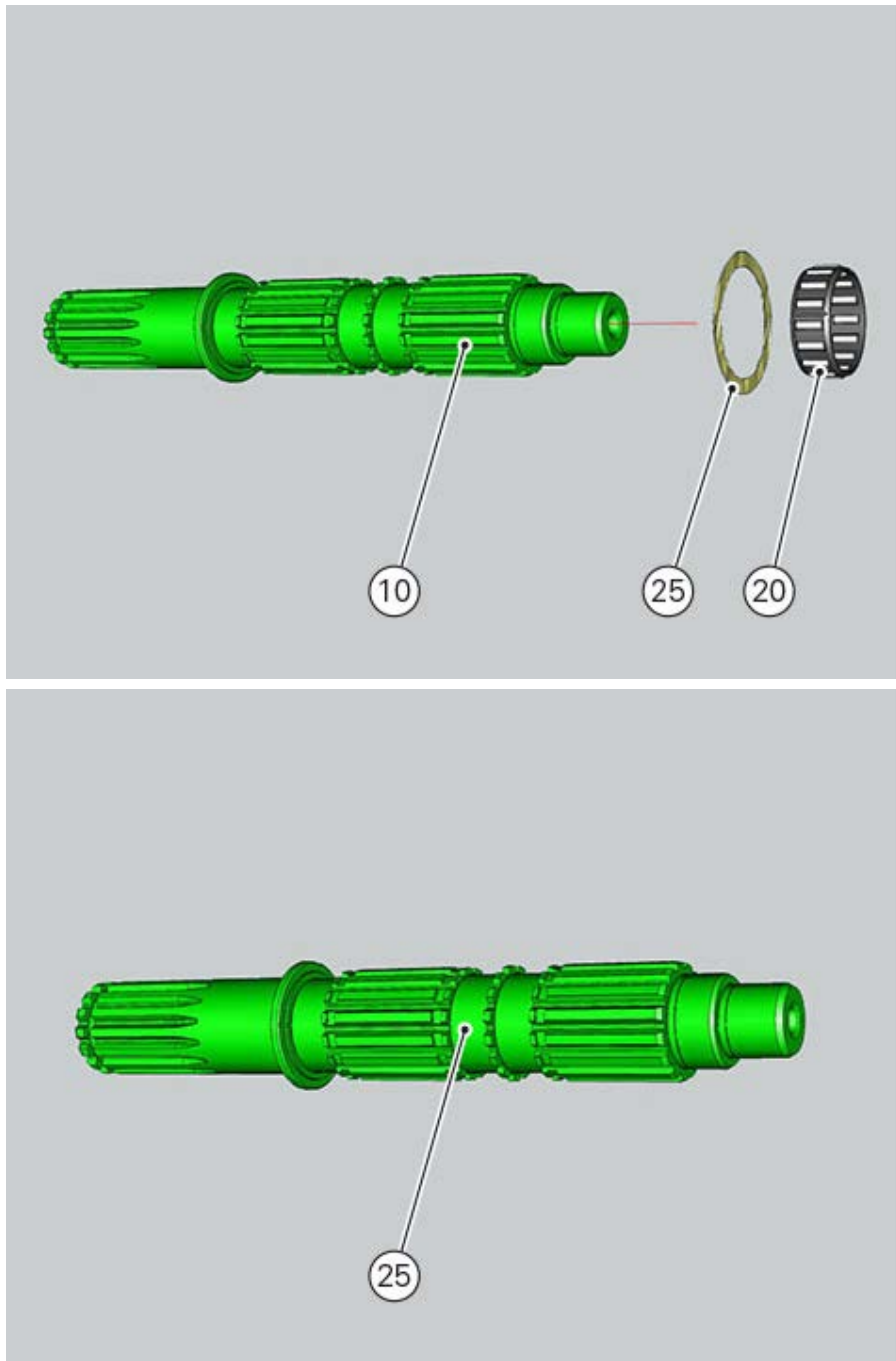

Disassembling the gearbox primary shaft

Remove washer (26) from the primary shaft.



Remove the second speed driving gear (28). Use two screwdrivers to prise out the snap ring (17) and the splined washer (18).

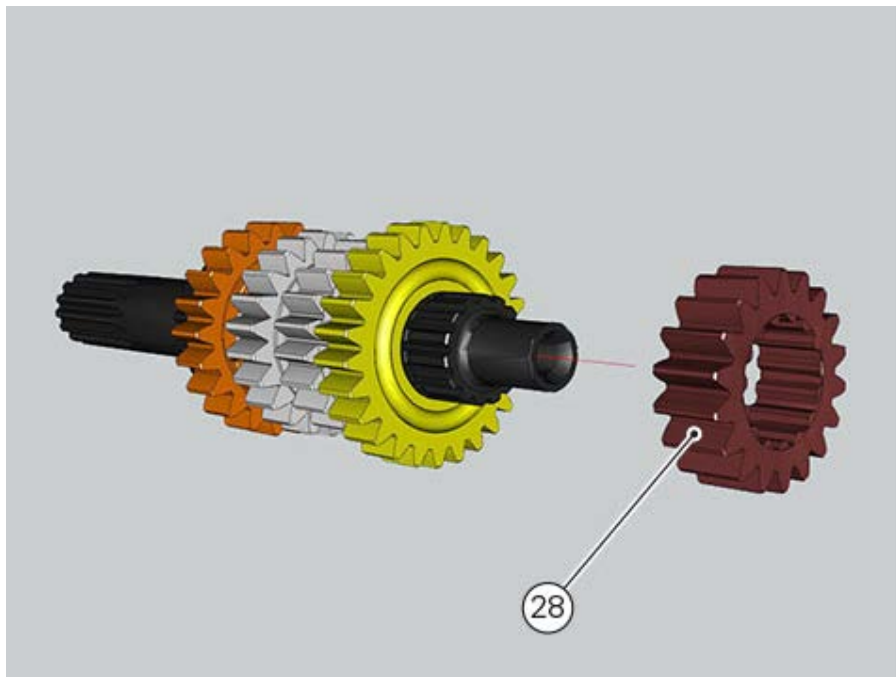

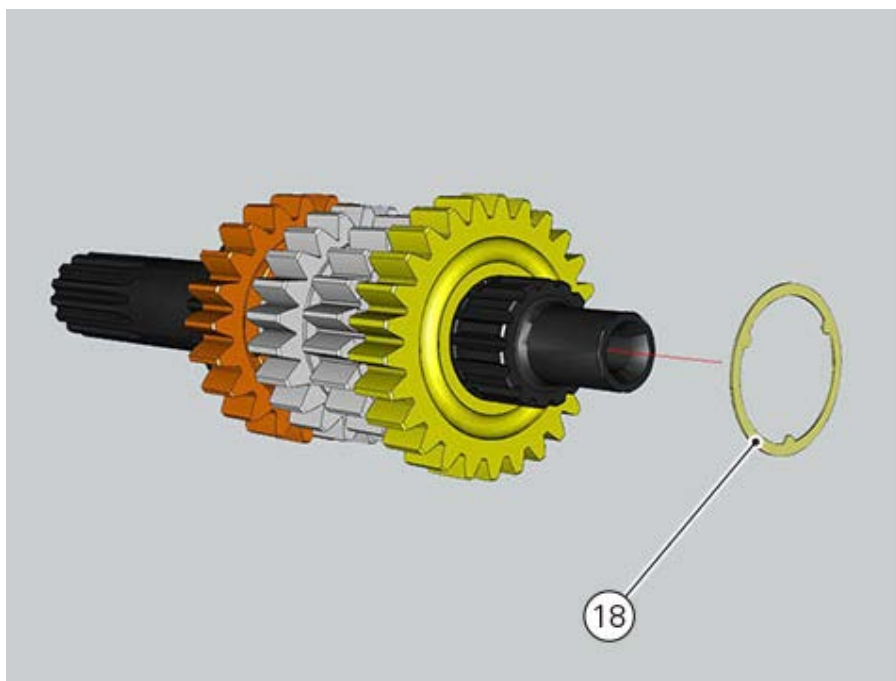
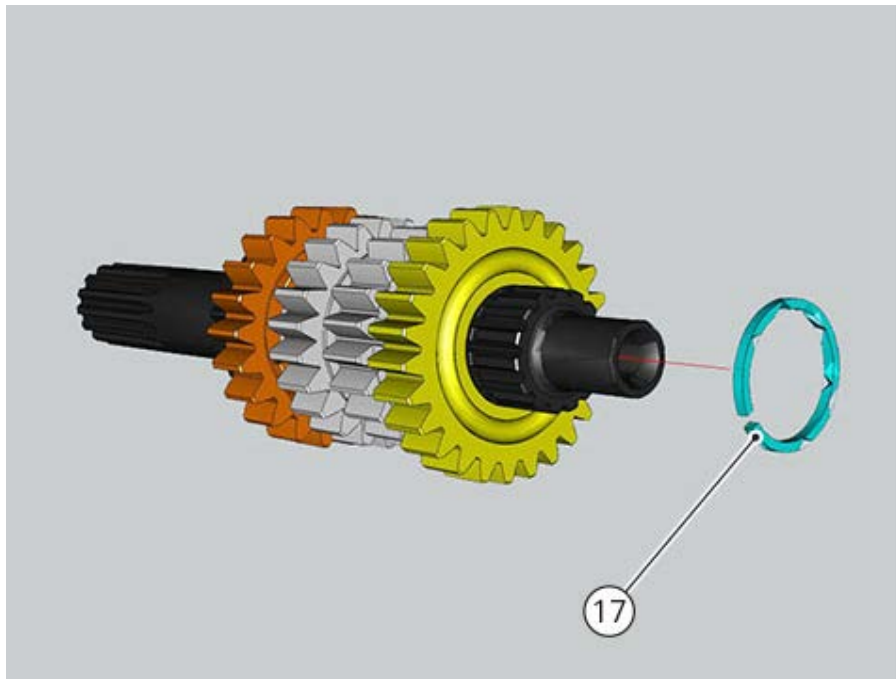

Important

Take care to avoid damaging the surface of the shaft while removing the snap ring.

Remove the sixth speed driving gear (29) with its roller cage (20).
Then remove the splined washer (18) and the snap ring (17).

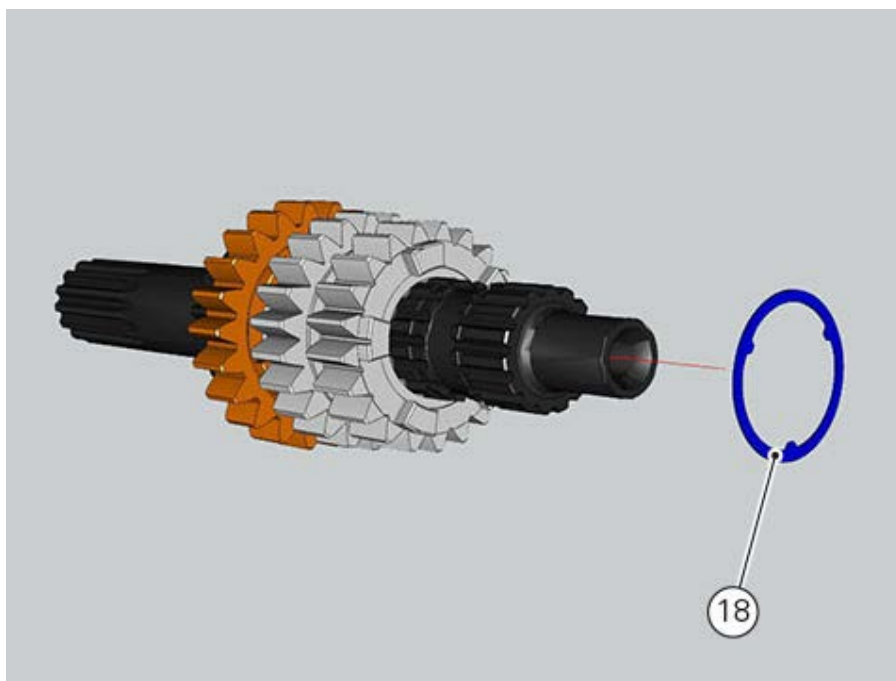
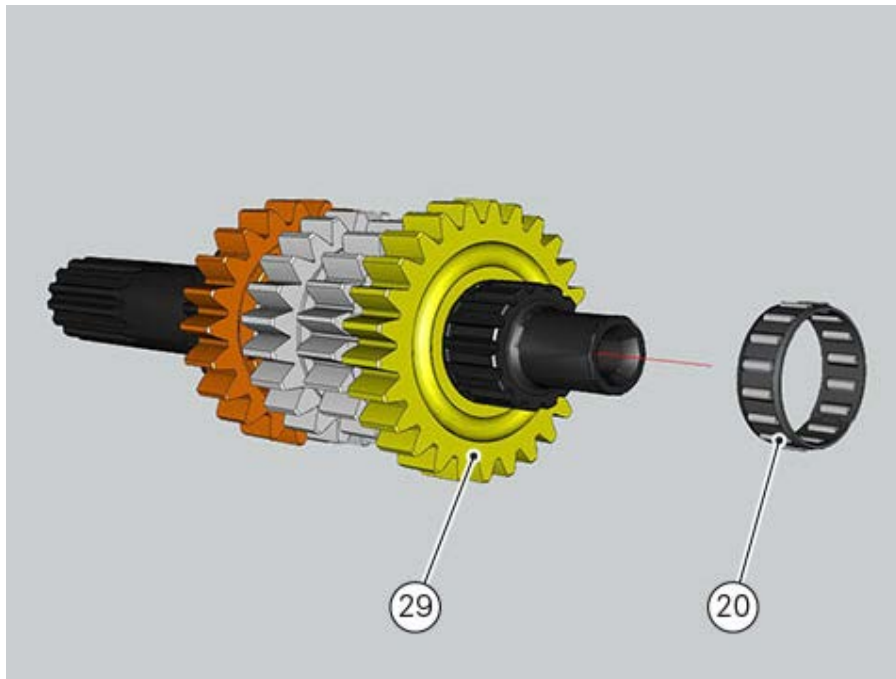

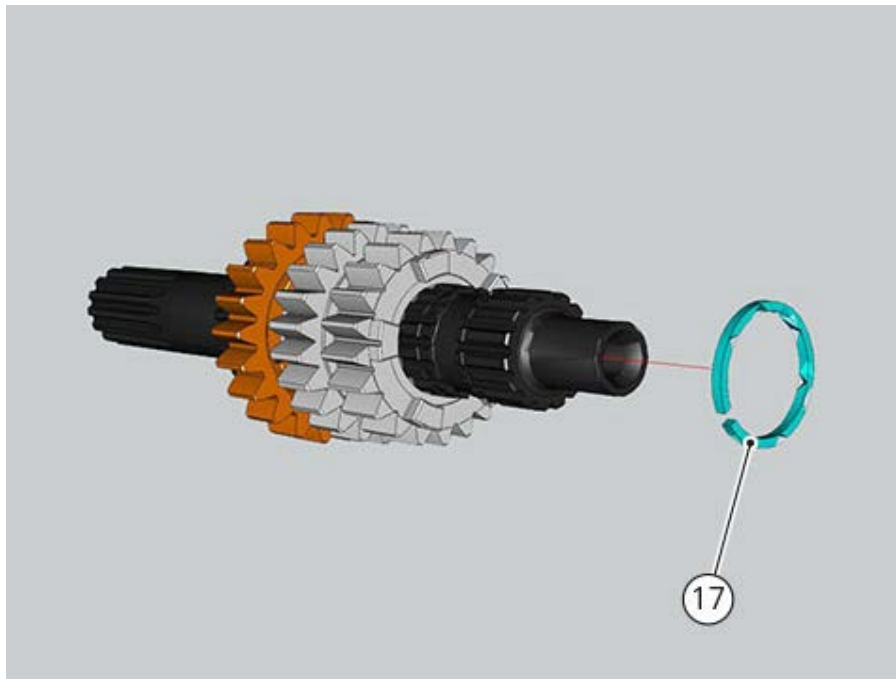

Withdraw the third and fourth speed driving gear (30).

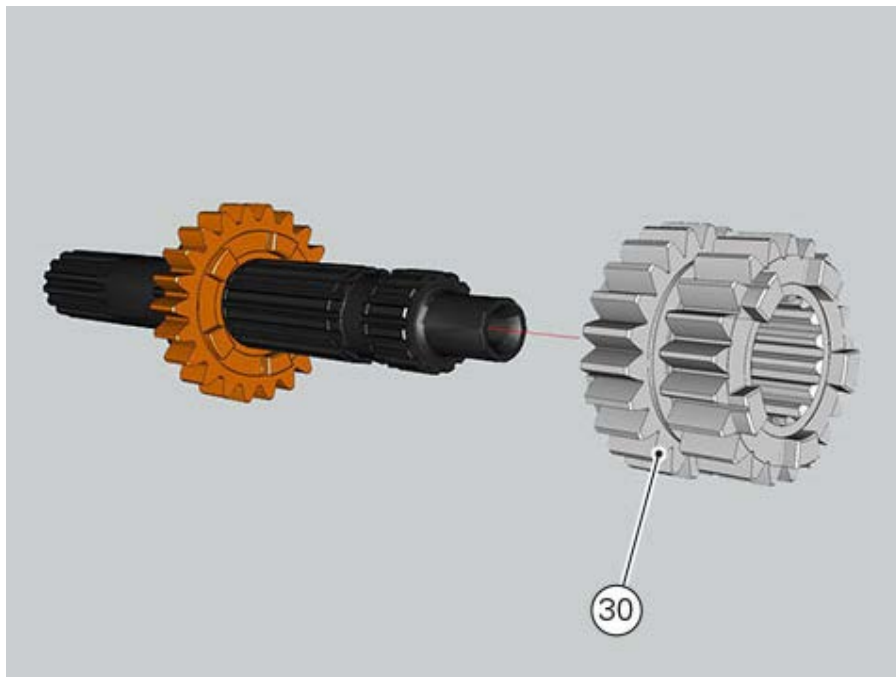

Remove the snap ring (17) and the splined washer (18).

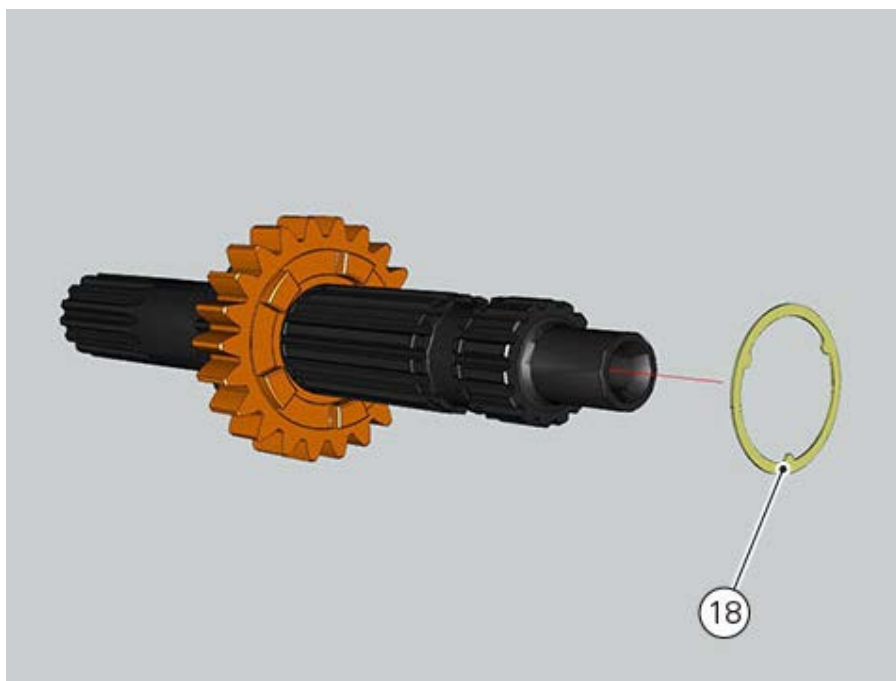
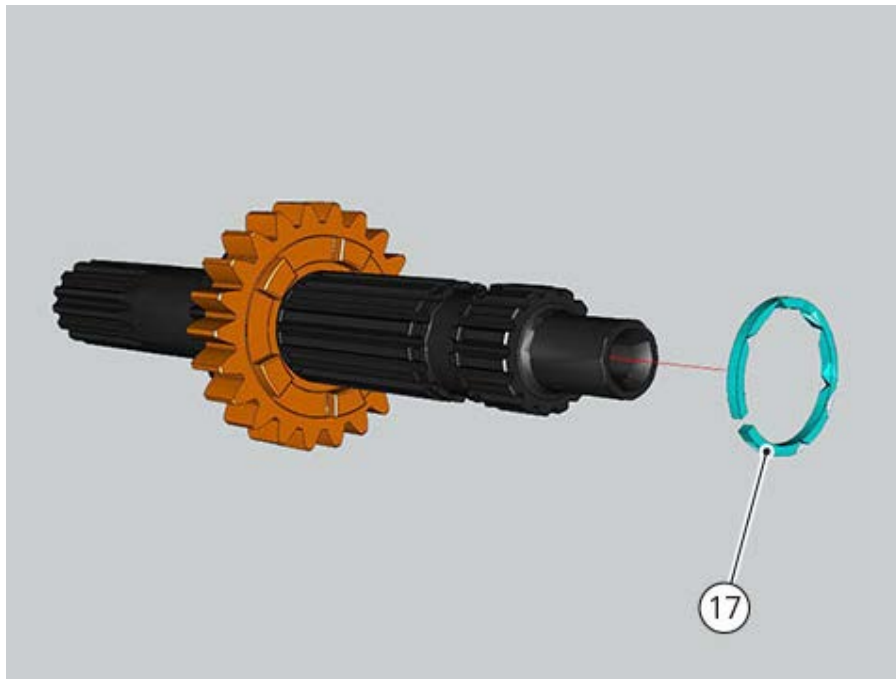

Remove the fifth speed driving gear (31) with its roller cage (20).

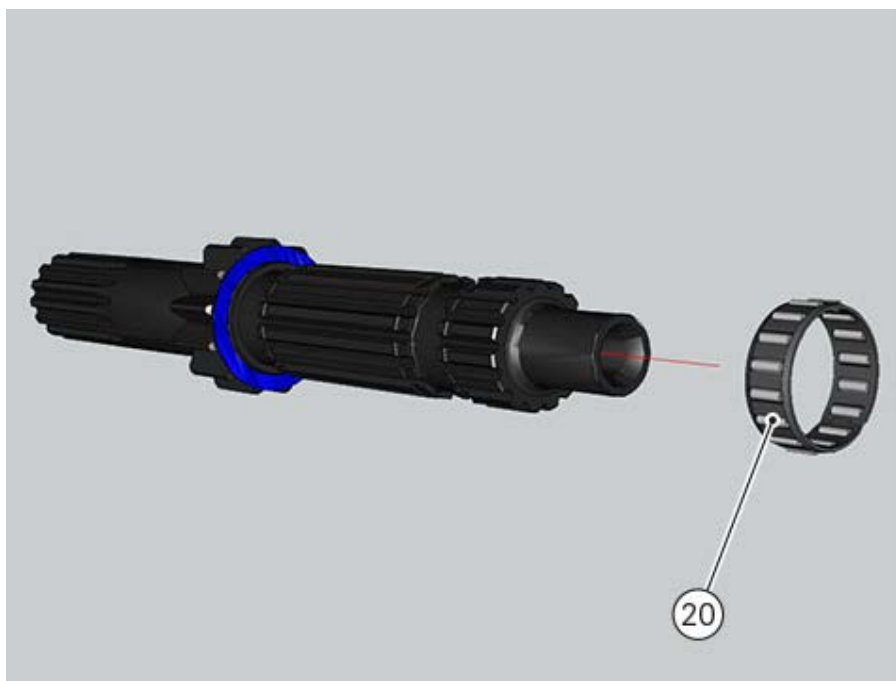
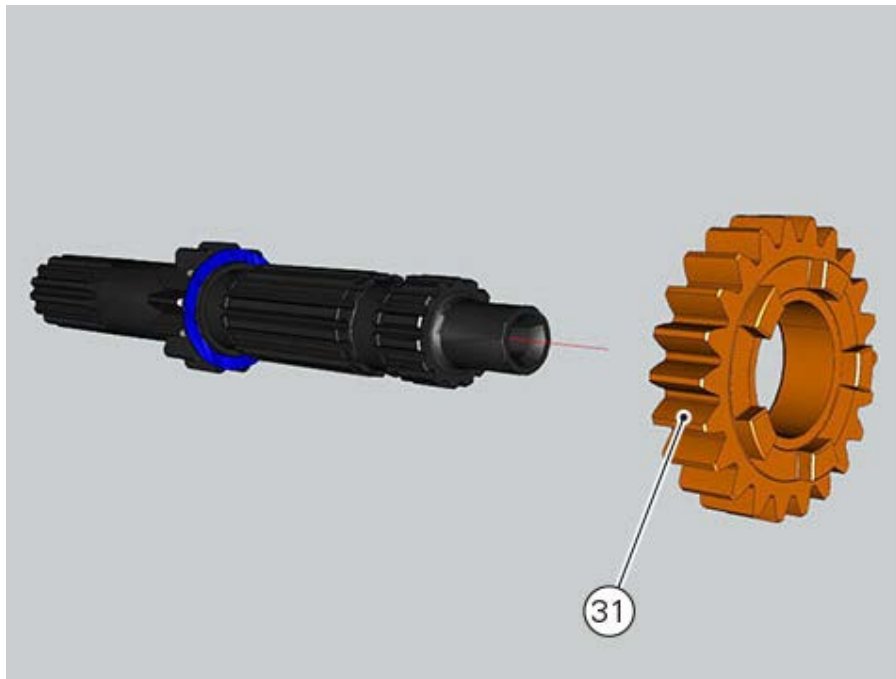

Slide out washer (25) from the primary shaft (9).

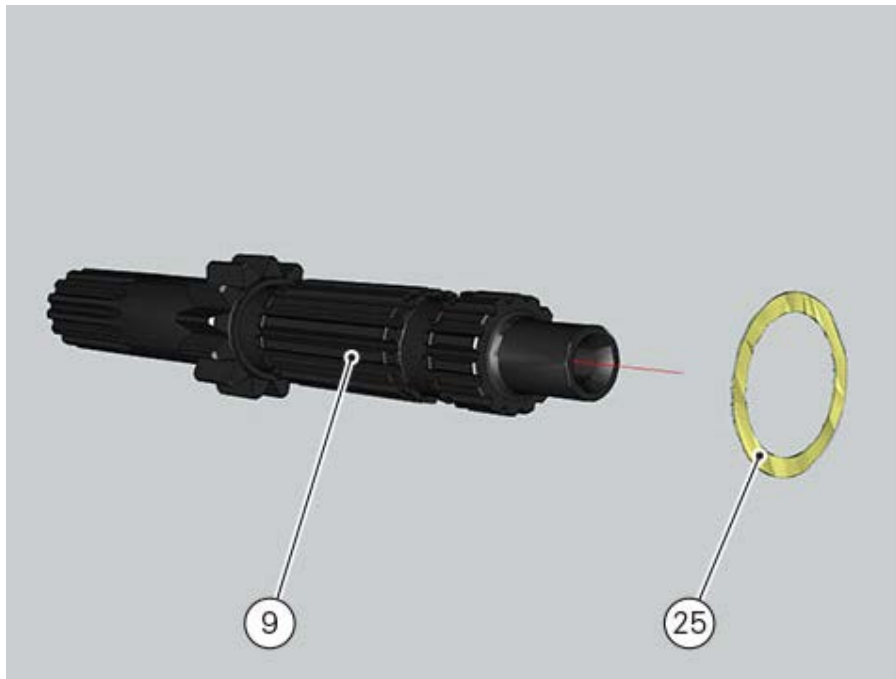

Removing the gearbox assembly

Withdraw the selector fork shafts (1).

Move the forks (2) and (3) to disengage them from the slots in the selector drum.

Remove fork selector drum (4) paying attention not to invert the shims (5) and (6) fitted on the shaft.

Once removed, it is possible to replace block ring (7) and special needles (8).

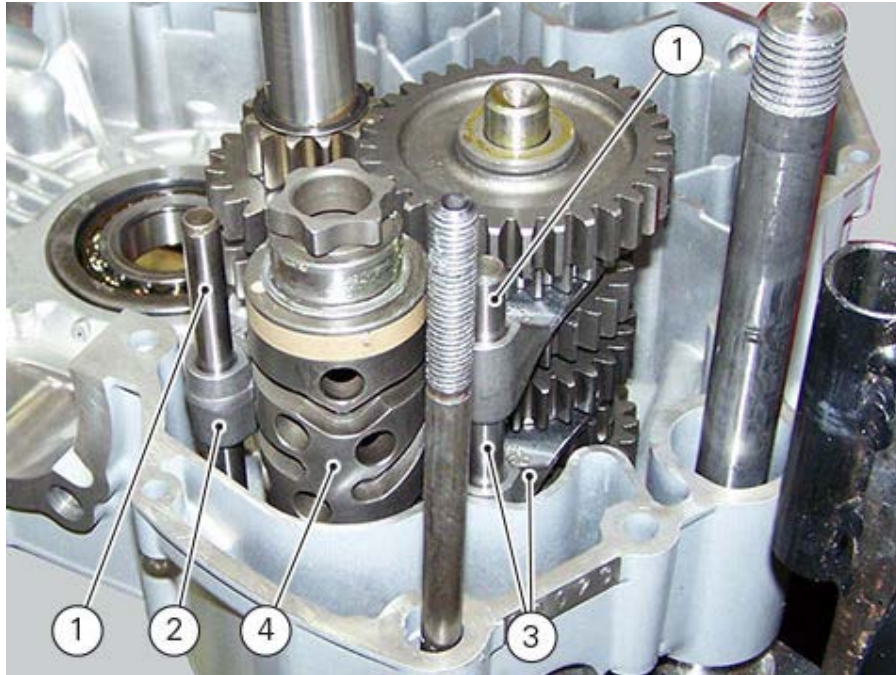

Remove gear selector forks (2) and (3).

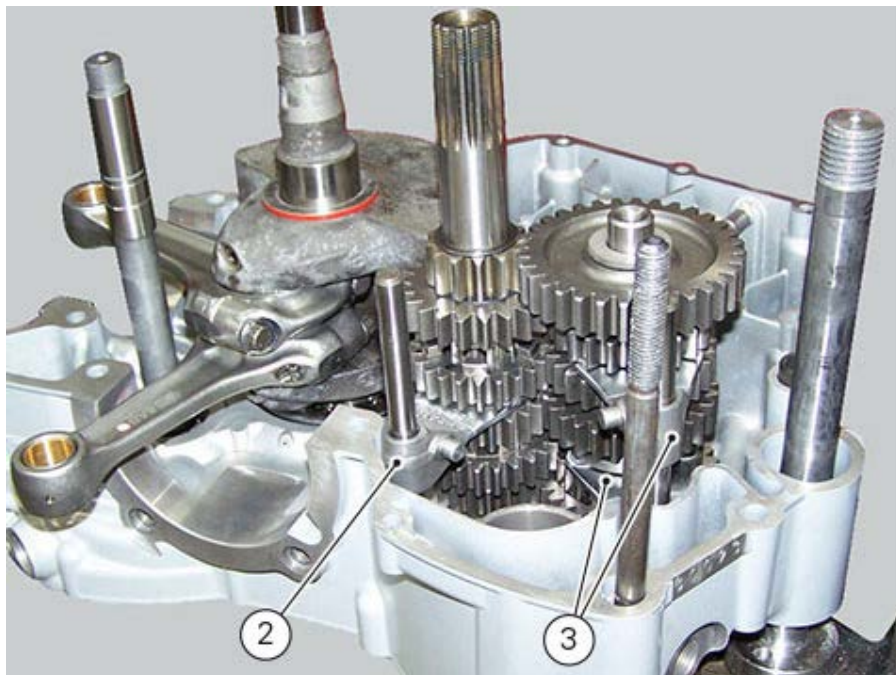

Remove the gearbox primary (9) and secondary (10) shafts complete with gears, taking care to recover the shim washers on the ends of the shafts.

If the bearing inner rings are left on the shafts, slide them off the ends of the gearbox primary (9) and secondary (10) shafts.

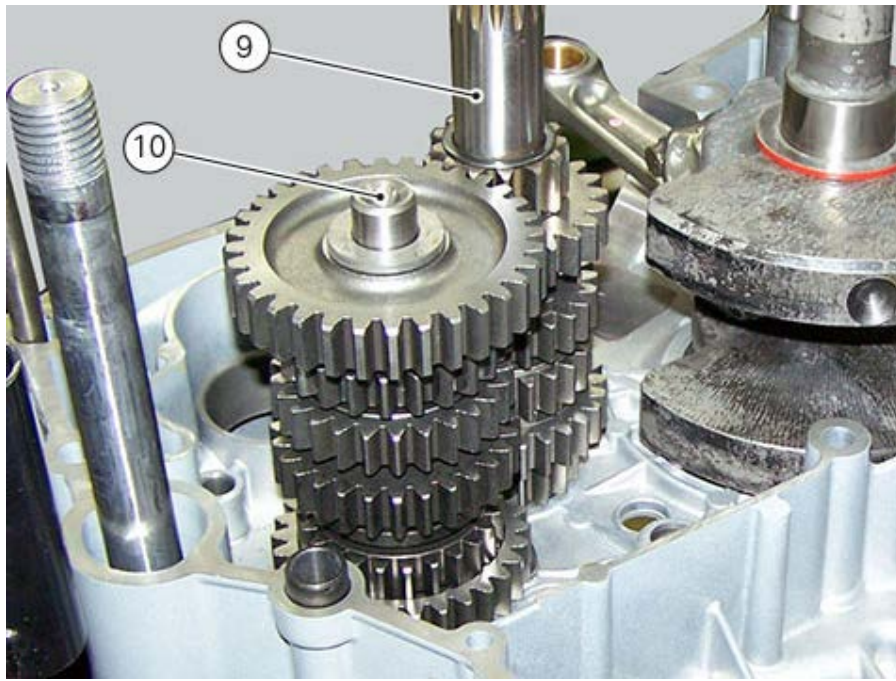

Remove them from the shaft ends and fit them in the relevant bearings on the crankcase half.

Refitting the flywheel/generator assembly

If previously disassembled, reassemble the flywheel following the indications described below.

Fit starter clutch (27) on flywheel (23).
Bring the starter clutch edge (B) fully home on the flywheel.
Position flange (28) on the flywheel and start screws (24).
Tighten screws (24).

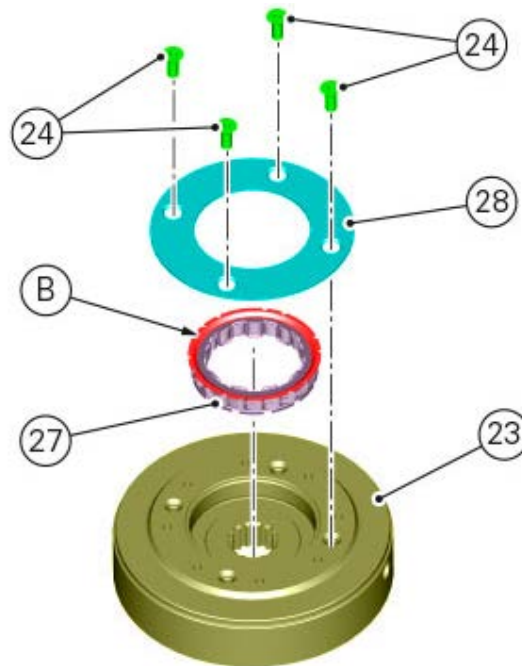

Position rotor (26) on flywheel (23).
Apply the indicated threadlocker and start screws (22).
Tighten screws (22) respecting the indicated sequence to a torque of 13 Nm (Min 11 Nm Max 15 Nm).

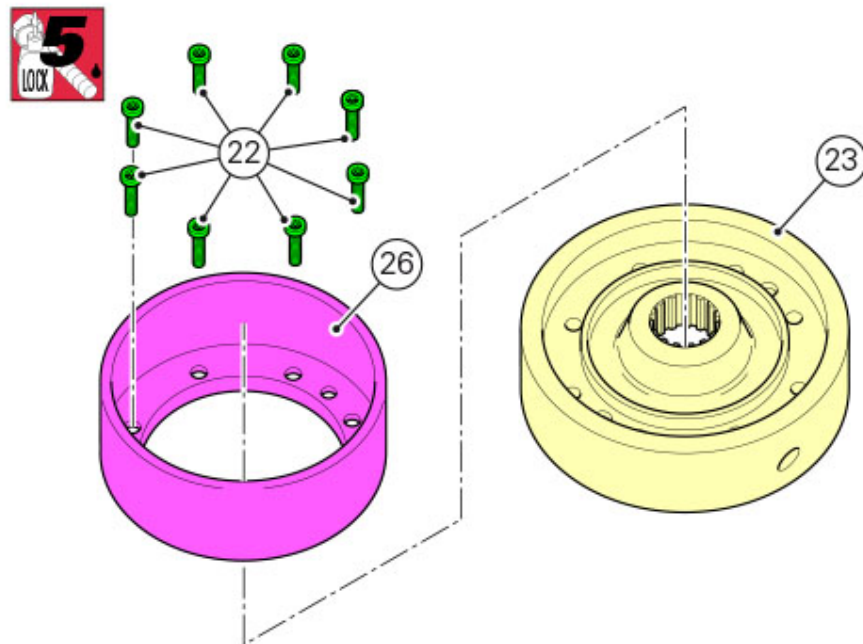

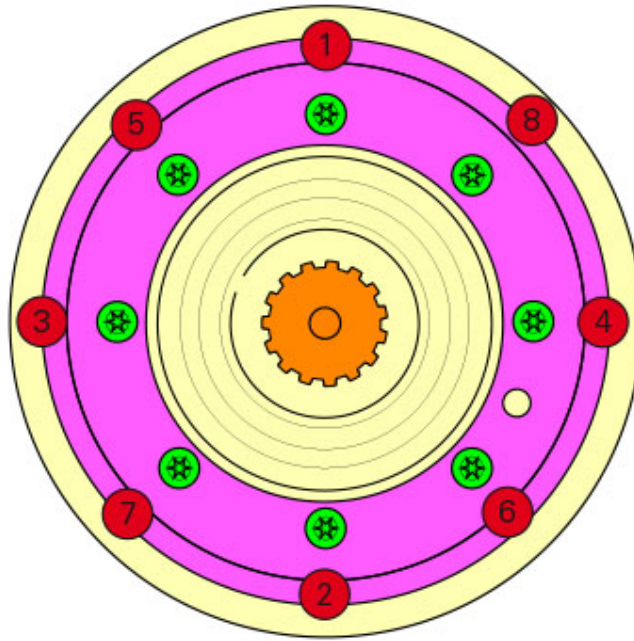

Fit on the crankshaft the washer (21), duly lubricated, roller bearing cage (20) and the internal ring (19) so that the latter is centred in the washer.

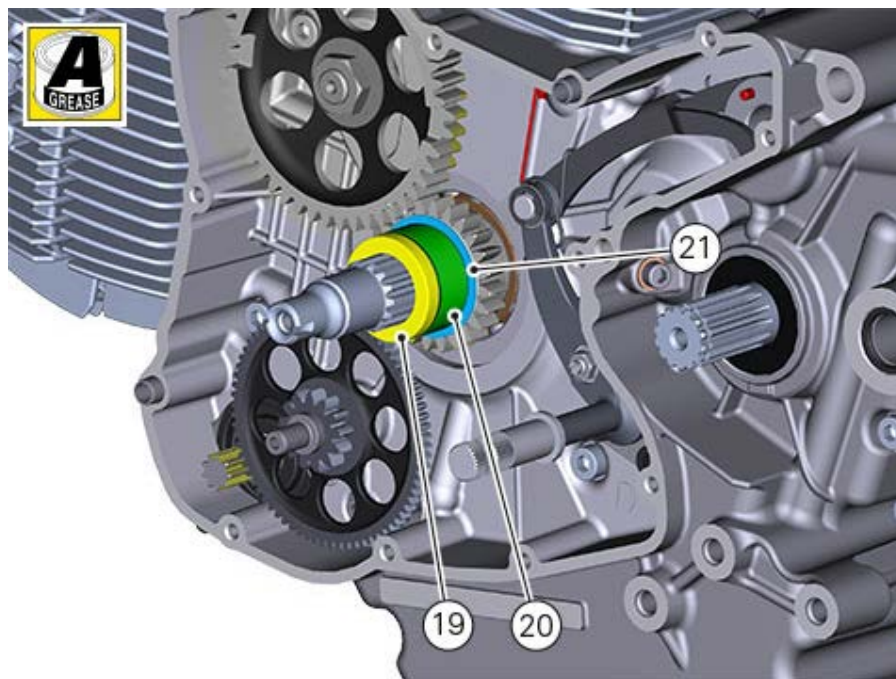

Install the flywheel-rotor-driven gear assembly on the crankshaft ensuring not to move the internal ring (19) in washer (21).

The flywheel assembly must be positioned with the reference sign aligned with the crankshaft groove, near the key seat.

Use engine oil to lubricate the mating surfaces of the belleville washer (16).

Fit the belleville washer (16) on the end of the crankshaft.

Smear both crankshaft threading and flywheel nut one (15) with specified threadlocker.

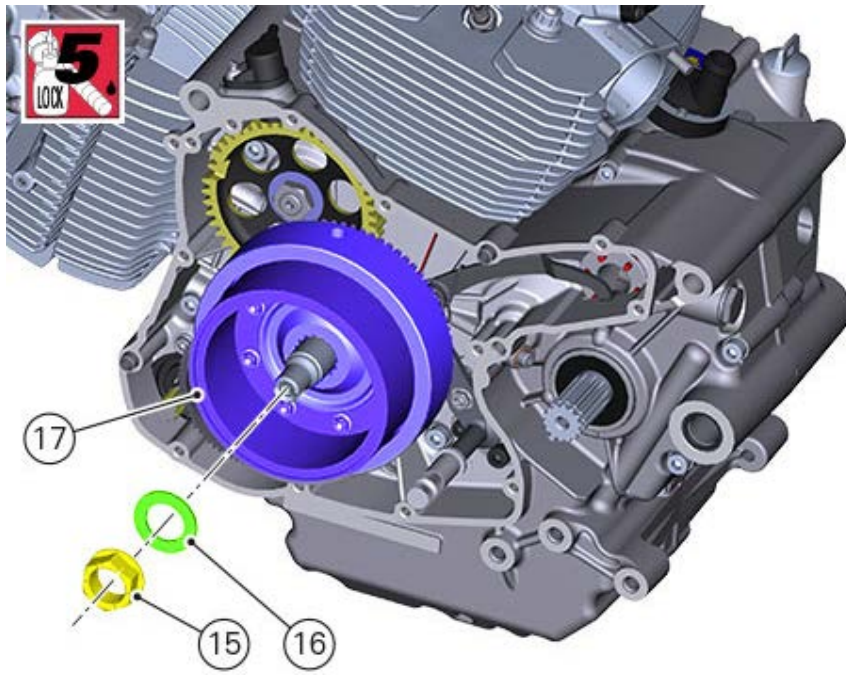

Block the flywheel rotation with the suitable tool (A) no. **88713.2036**.
Tighten nut (15) to a torque of 270 Nm (Min. 256 Nm - Max. 284 Nm)

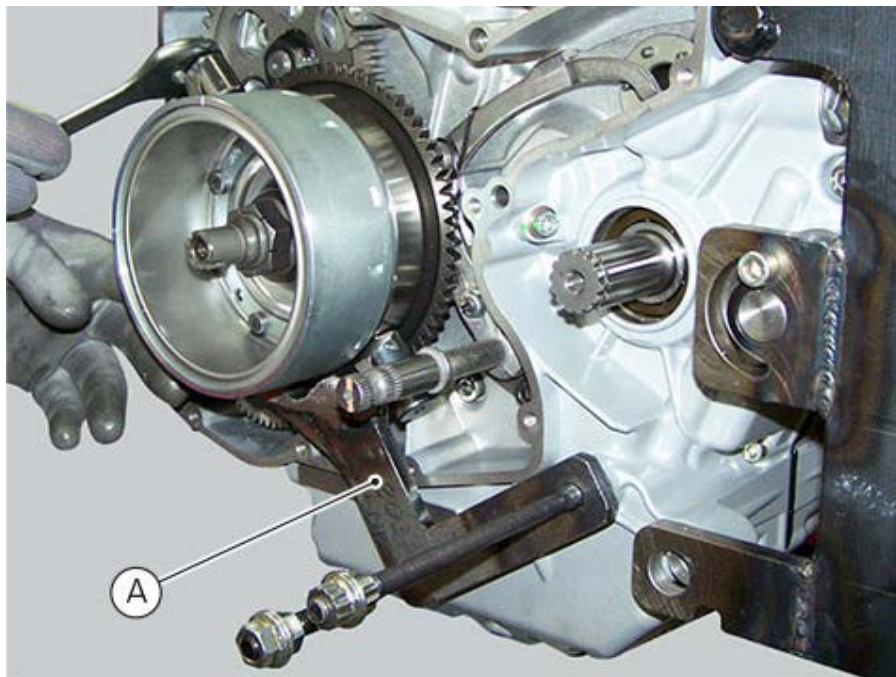

Overhauling the flywheel/generator assembly

Inspect the inner part of generator rotor (8) for signs of damage.

Check that the starter clutch is working properly and that the roller races do not show signs of wear or damage of any kind.

Disassemble the unit if you find faulty operation.

Removing the flywheel/generator assembly

Fix tool (A) part no. **88713.2036** to the mounting holes (14) of side stand. Secure the tool to the flywheel with the suitable screws.

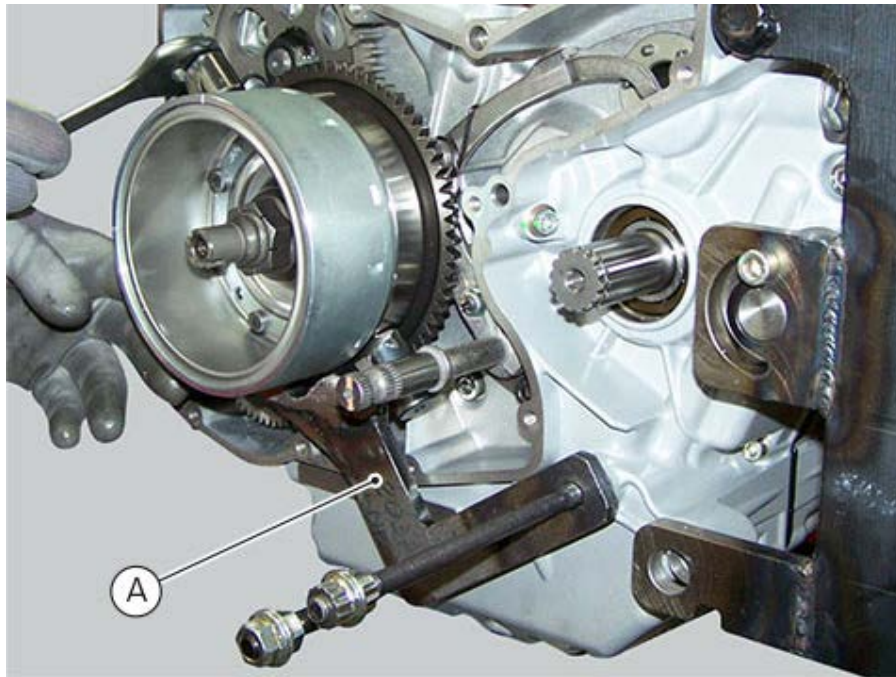

Loosen nut (15) securing the generator flywheel by heating it up with an "industrial heating gun"; we recommend not to use naked-flame heating methods that could damage the starting components.

Warning

While unscrewing the nut, apply axial pressure to the socket to avoid damage or injury in the event of the wrench suddenly slipping off the nut.

Remove nut (15), Belleville washer (16) and the flywheel assembly (17) with gear (18).

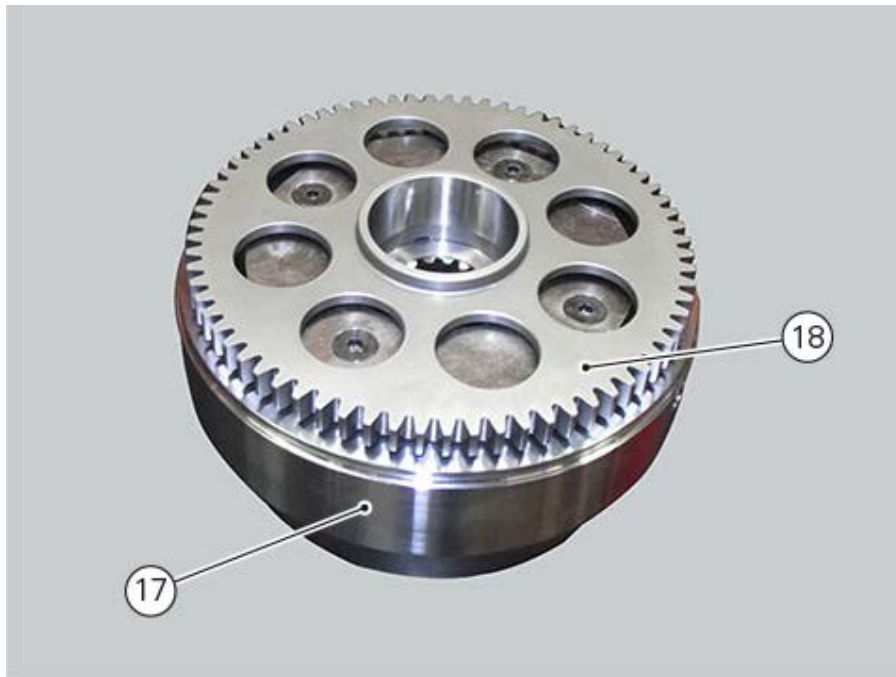
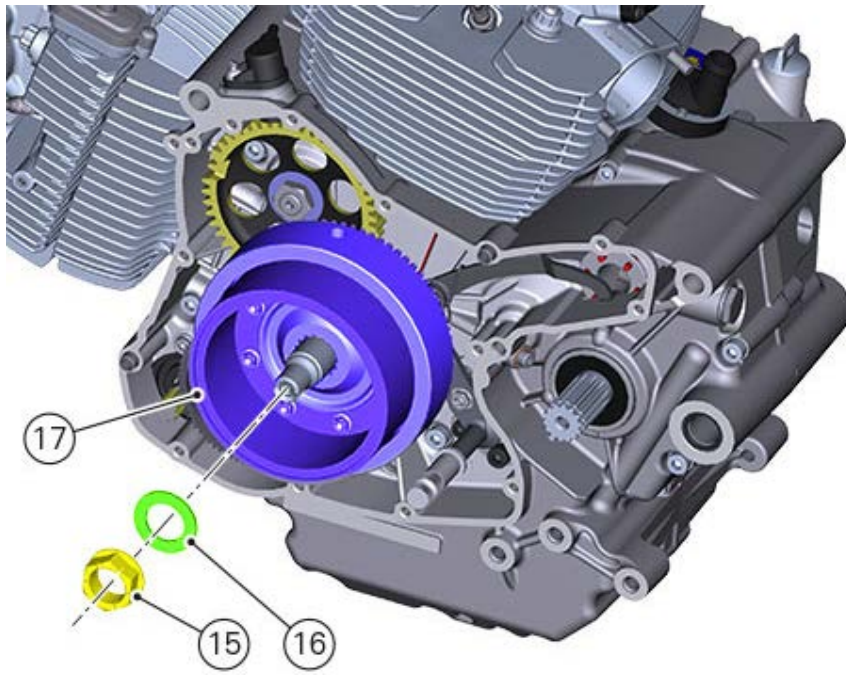

Remove the inner ring (19), the needle roller bearing cage (20) and the washer (21).

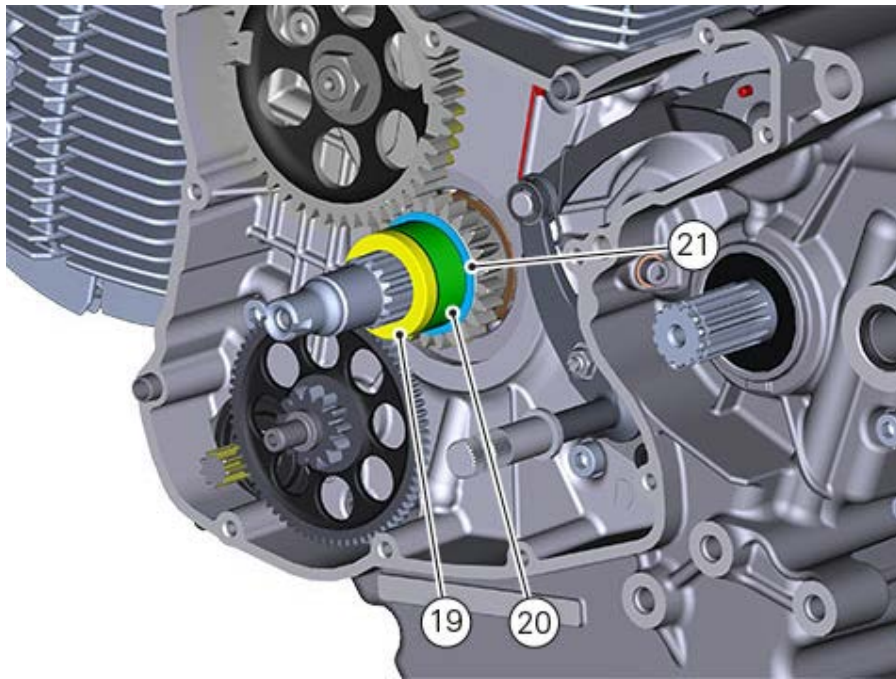

Checking the flywheel/generator assembly

Inspect the inner part of generator rotor for signs of damage.
 Check that the starter clutch is working properly and that the roller races do not show signs of wear or damage of any kind.
 Disassemble the unit if you find faulty operation.

Disassembling the flywheel/generator assembly

Unscrew the eight screws (22) and remove the generator rotor (26) from the flywheel (23).

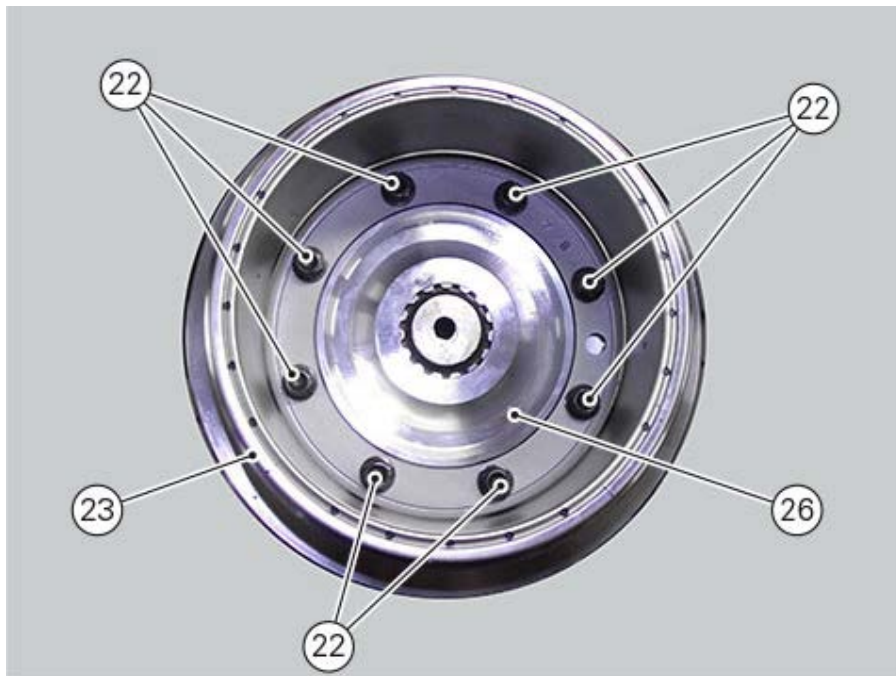

Working on the opposite side, loosen the four screws (24) and remove the flange (26).
 Remove the starter clutch (27).



Refitting the generator cover

Remove any scale and grease from the mating surfaces of the left-hand crankcase half and the generator cover.

Fit the two centring bushes (26).

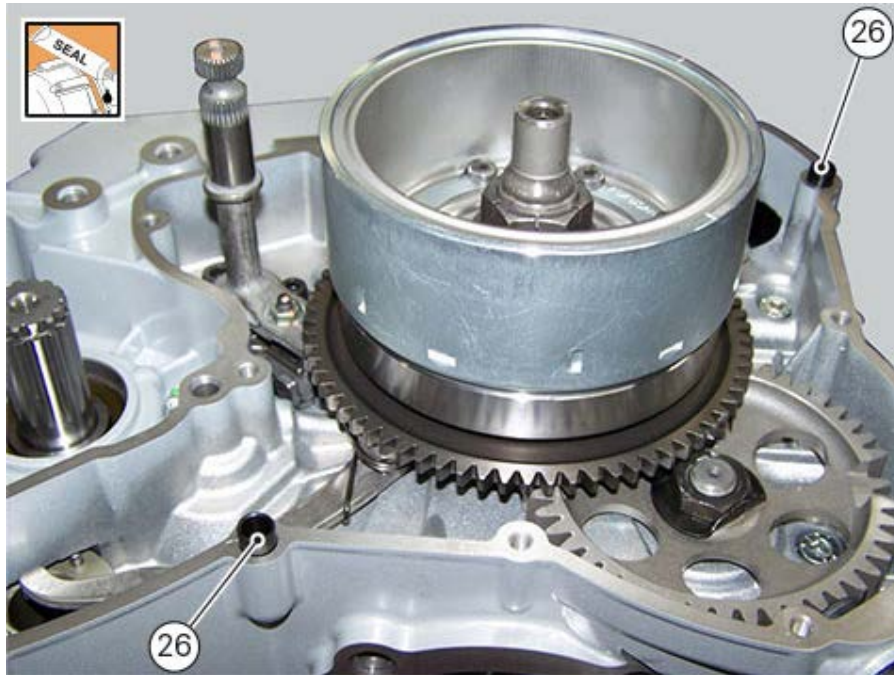

Spread a continuous uniform bead of DUCATI sealing compound on the cover mating surface, and around the holes of the screws and bushes.

Tap the cover at different positions with a rubber mallet to facilitate its location on the shafts and centring bushes.

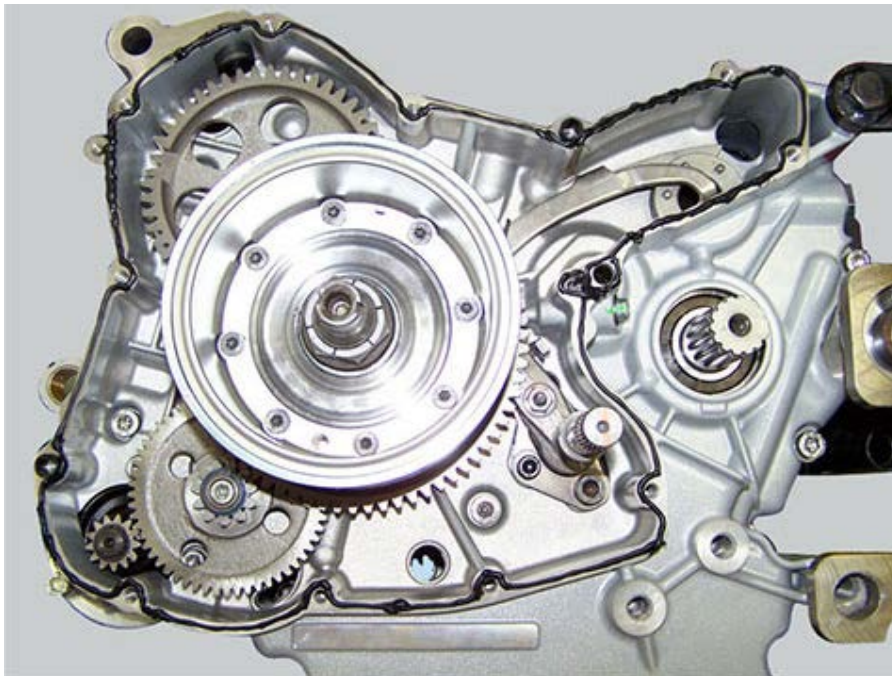

Insert the fixing screws in their holes following the indications given in the table.

Ref.	Q.ty	Description
3	2	6x20
4	10	6x30

Fit spacer and hose grommet (7) under screw (5) near the starter motor.
Tighten the screws in the indicated sequence.
Tighten to a torque of 13.5 Nm (Min. 12.5 Nm - Max. 14.5 Nm).

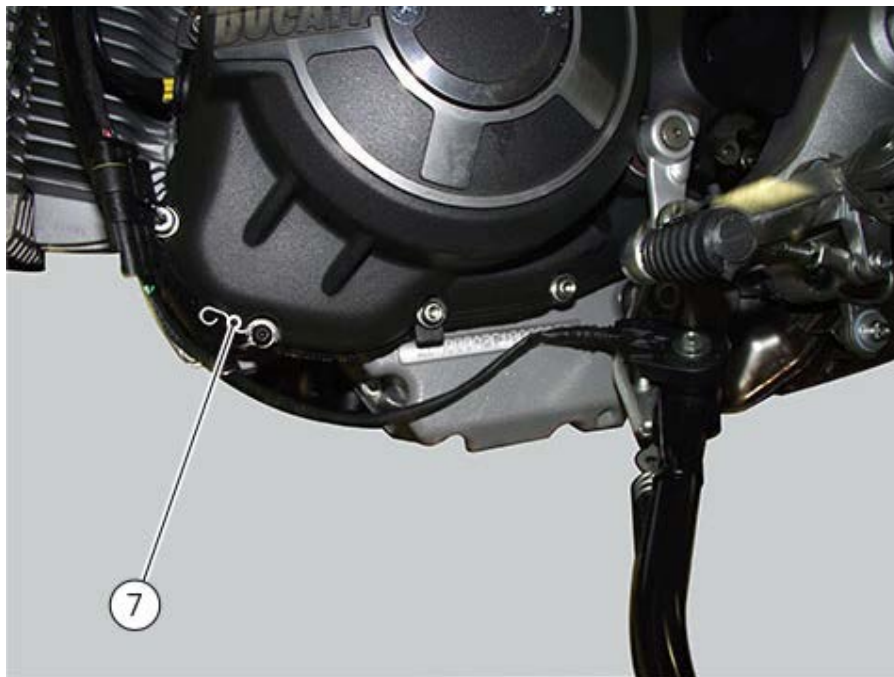
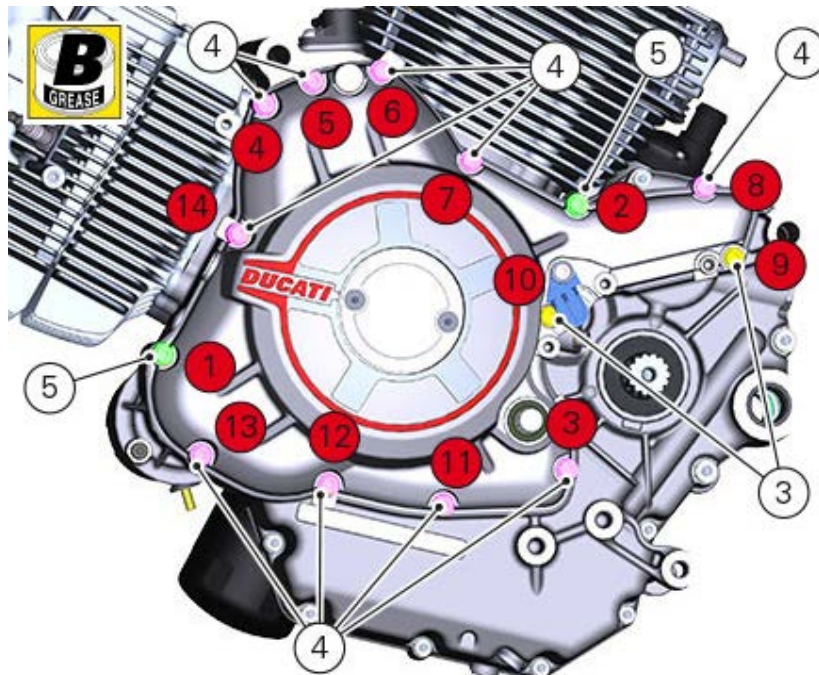

Use tool (B) part no. **88713.3394** on the gearbox driving shaft.

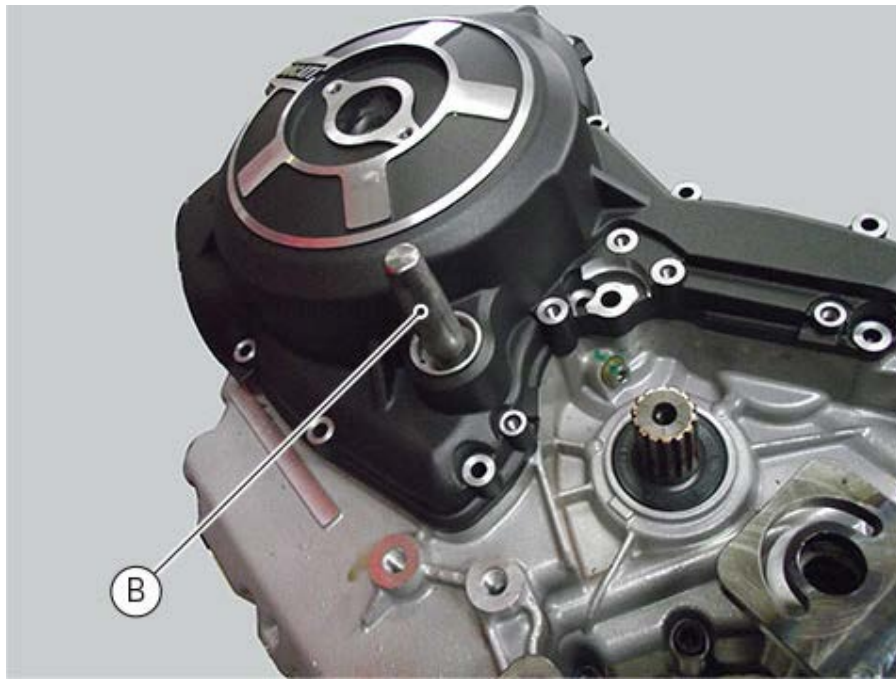

Lubricate oil seal (27) with the recommended product.
Fit oil seal (27) on the tool orienting it with the spring facing the inner side.

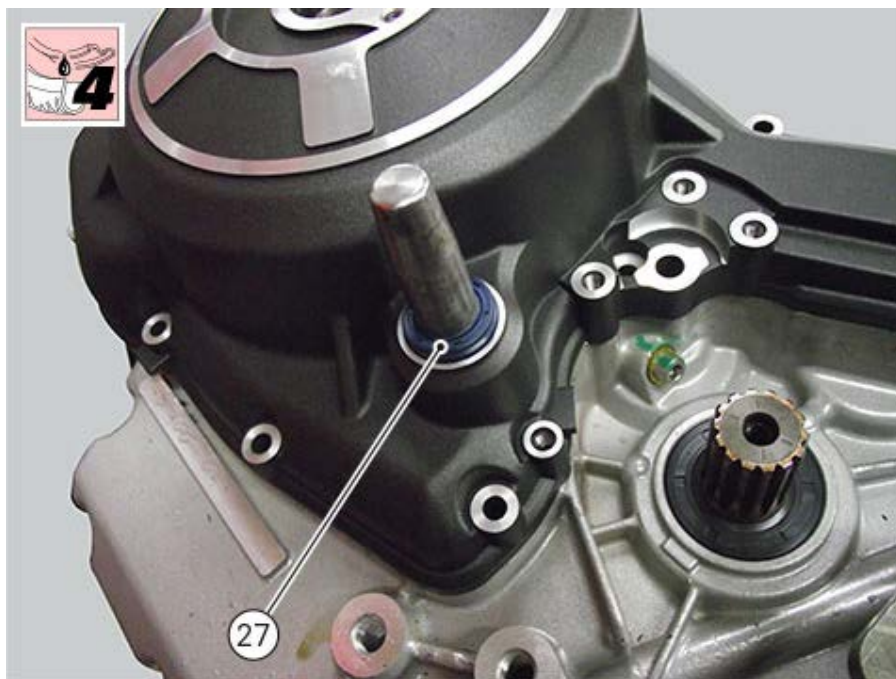

Fit the oil seal fully home with tool (C) no. **88713.3394**.
Remove tools (B) and (C).

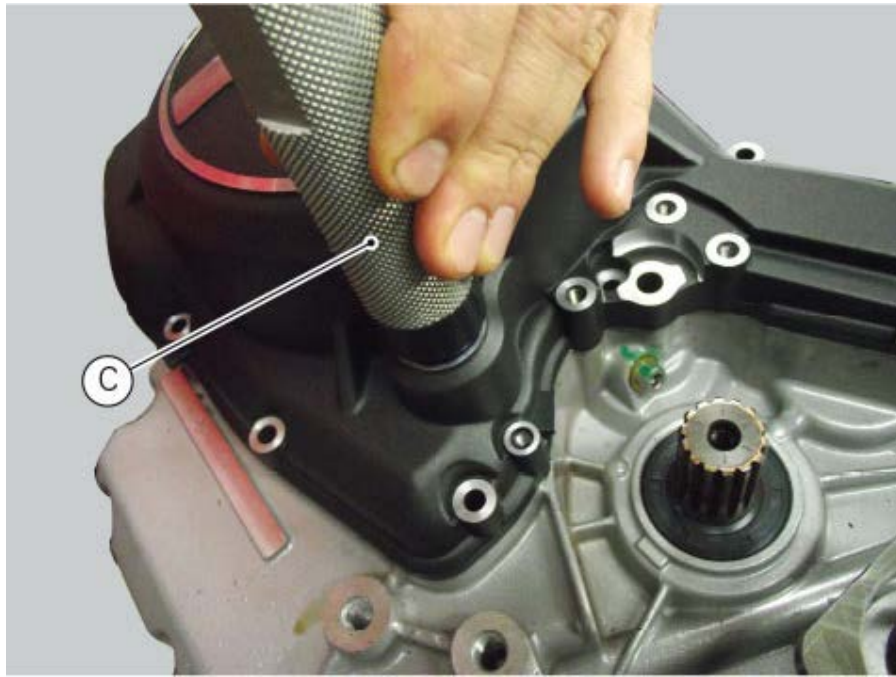

Make sure that the O-ring (28) is installed on the cover (2).
Apply grease to the screws (1).
Tighten the two fixing screws (1) of the cover (2) matching the crankshaft to a torque of 5 Nm (Min. 4.5 Nm - Max. 5.5 Nm).

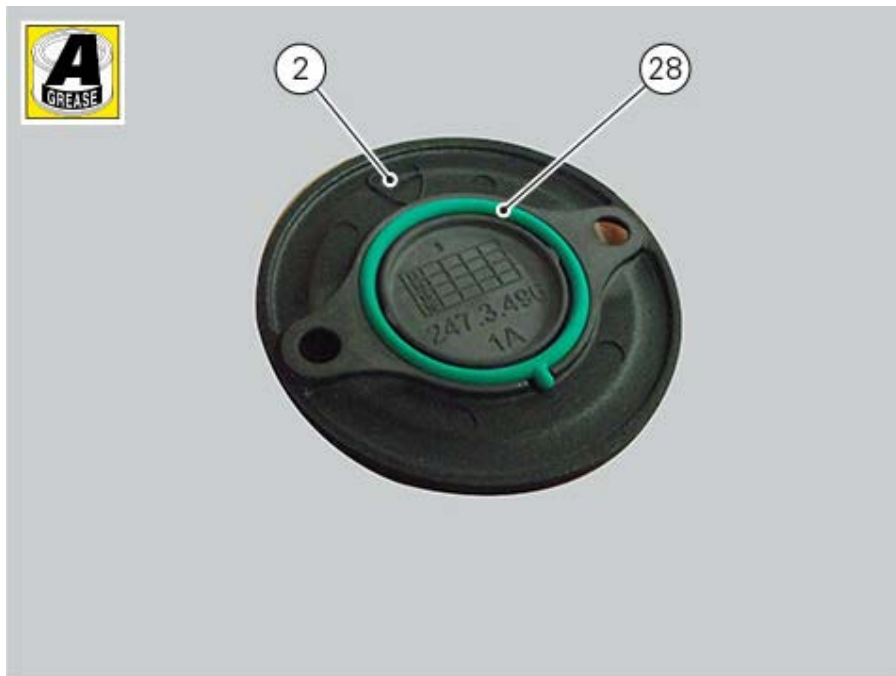

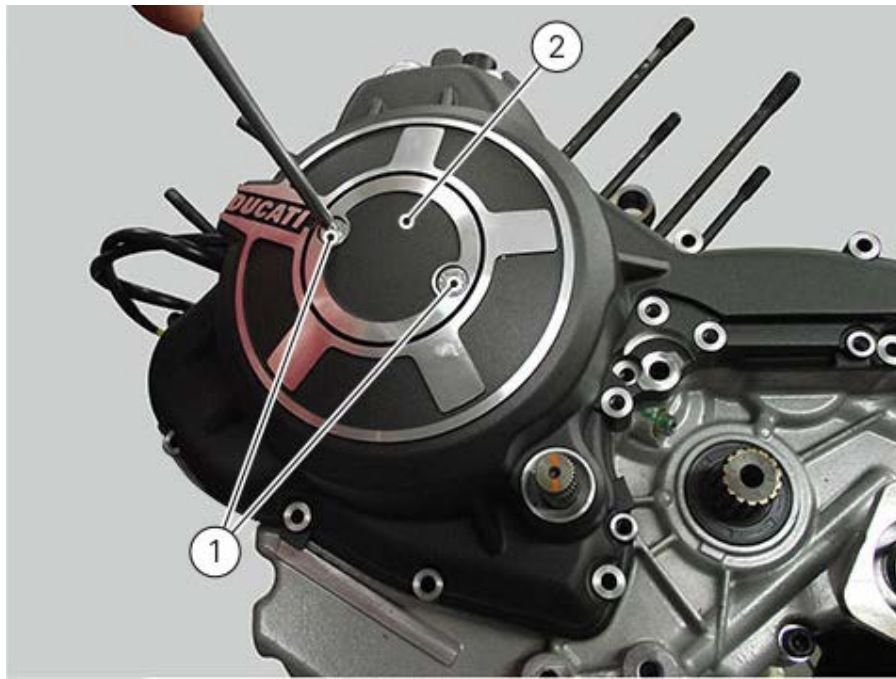

Refit the gear shift ([Refitting the gearbox unit](#)).

Fill the engine with oil ([Changing the engine oil and filter cartridge](#)).

Reassembling the generator cover

Install stator (10) on the generator cover, with the cable outlet facing the cover and pointing the cover recess.

Apply threadlocker on stator retaining screws (9) and tighten them to 10 Nm (Min. 9 Nm - Max. 11 Nm).
Install plate (11) above the cable.

Before the installation, make sure that bearing (12) on crankshaft end is installed with the relevant stop ring (13) on the generator cover (8).

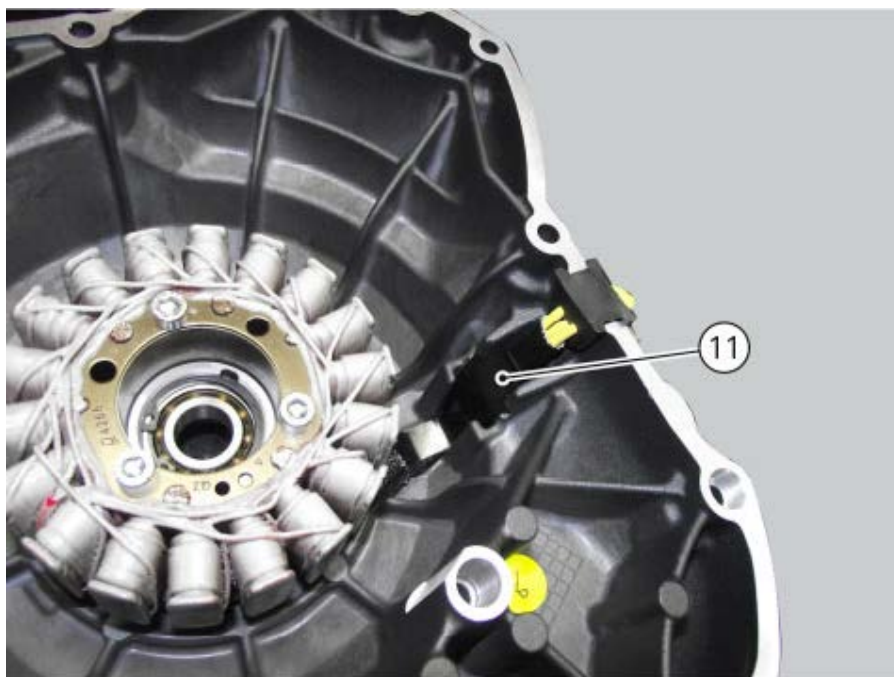
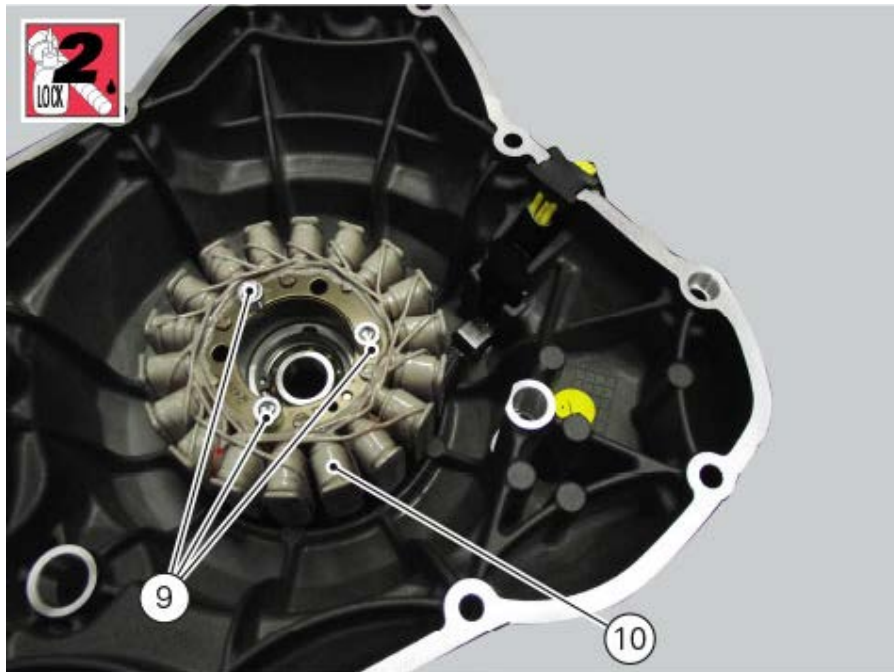

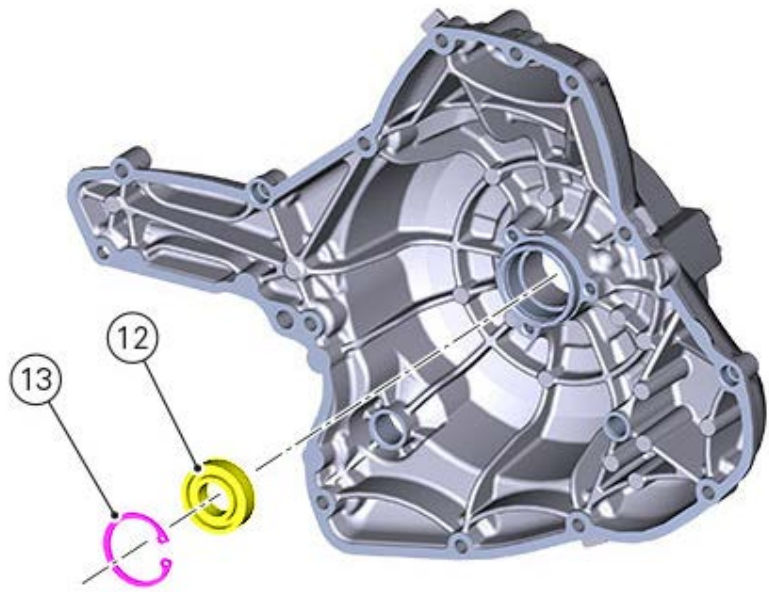

Disassembling the generator cover

Loosen the three screws (9) retaining the stator.
Remove the stator (10) and the cable guide bracket (11).

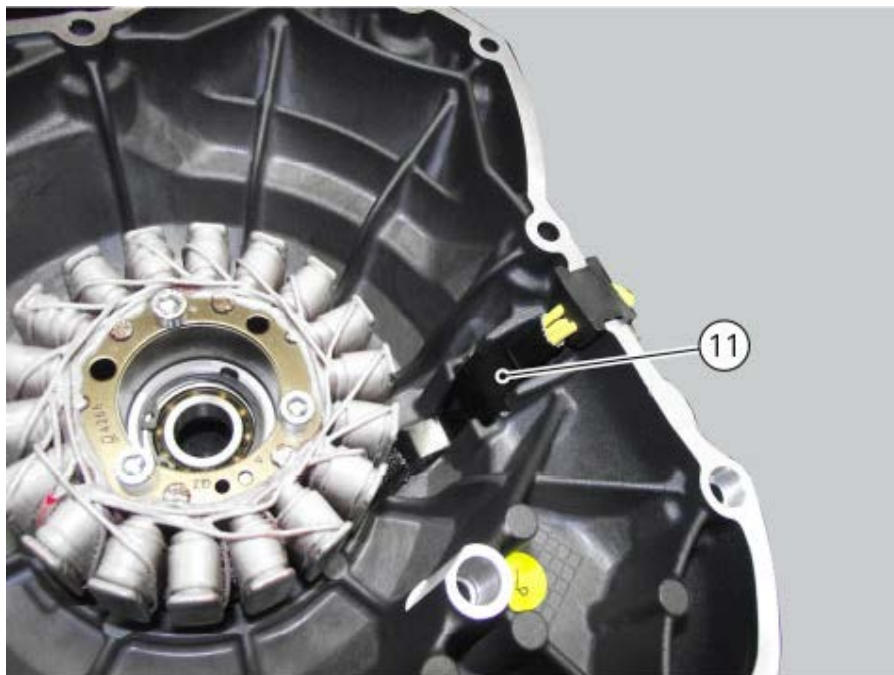
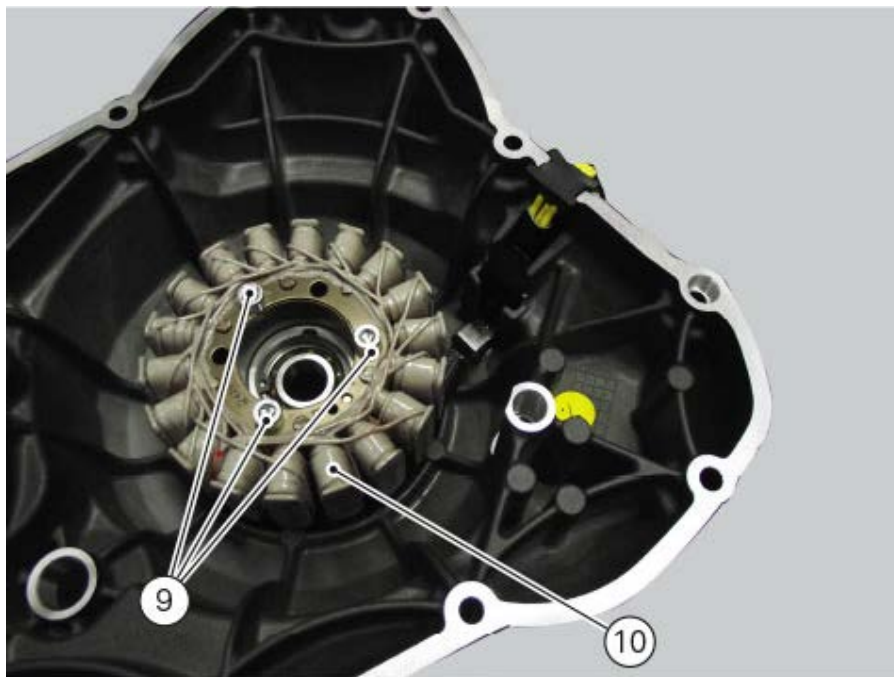

The generator cover is fitted with a bearing (12), held in place by the circlip (13), which is located on the end of the crankshaft.

Remove the circlip (13) with suitable pliers.
Remove the bearing (12) using a universal puller.

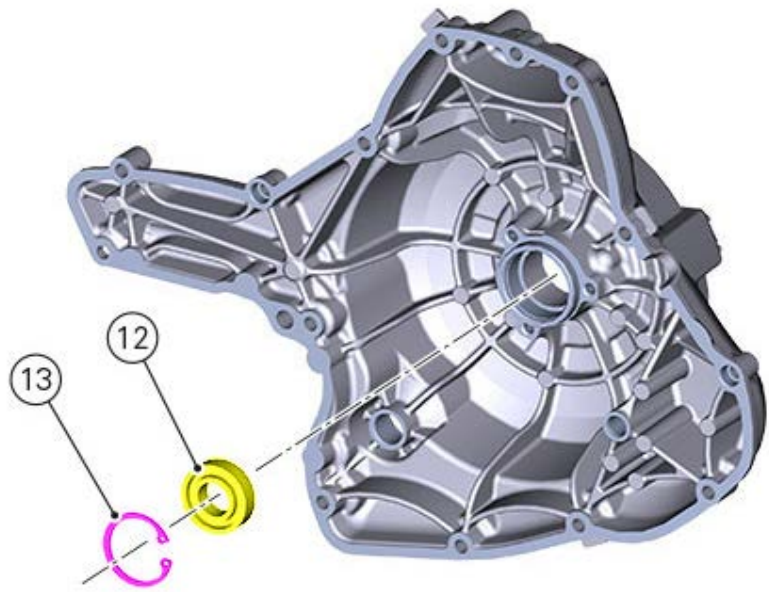

Removing the generator cover

Drain the engine oil ([Changing the engine oil and filter cartridge](#)).

Remove the gear shift ([Removing the gear shift](#)).

Remove the front sprocket cover ([Removing the front sprocket cover](#)).

Undo the two retaining screws (1) of the centre cap (2) over the end of the crankshaft.

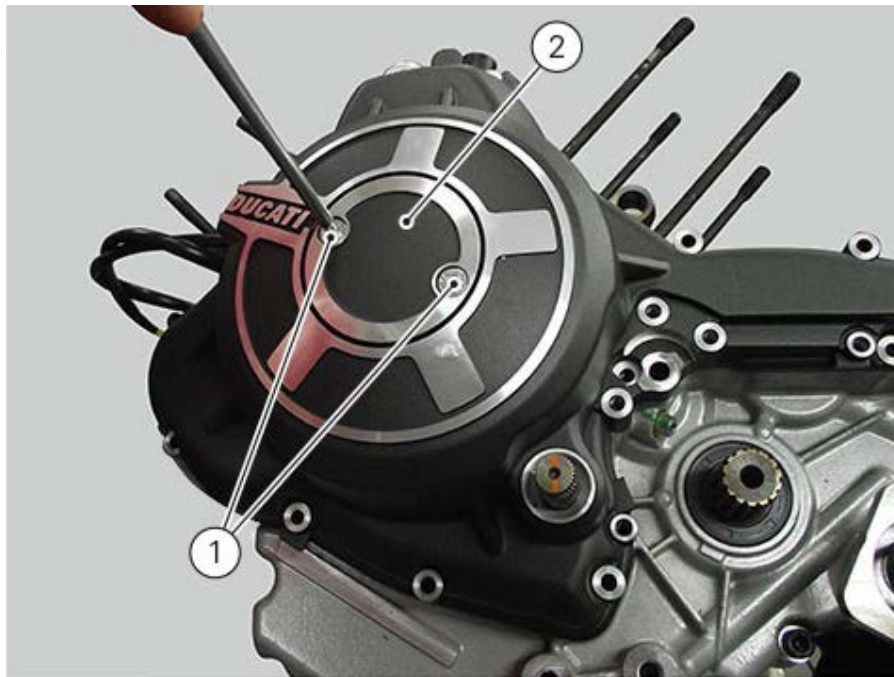

Loosen the fastening screws (3), (4), (5) and (6) on the generator cover. Collect hose grommet (7).

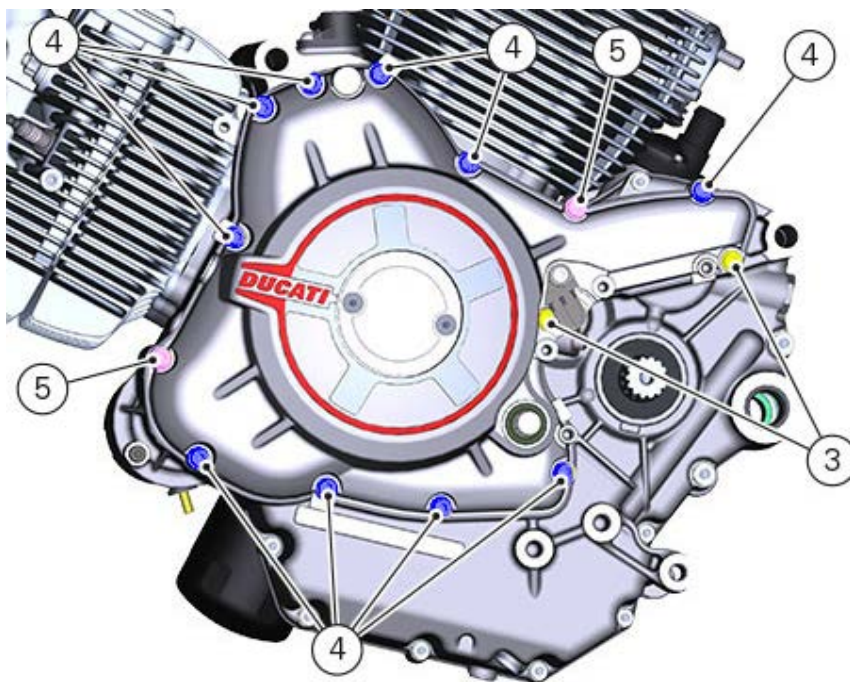

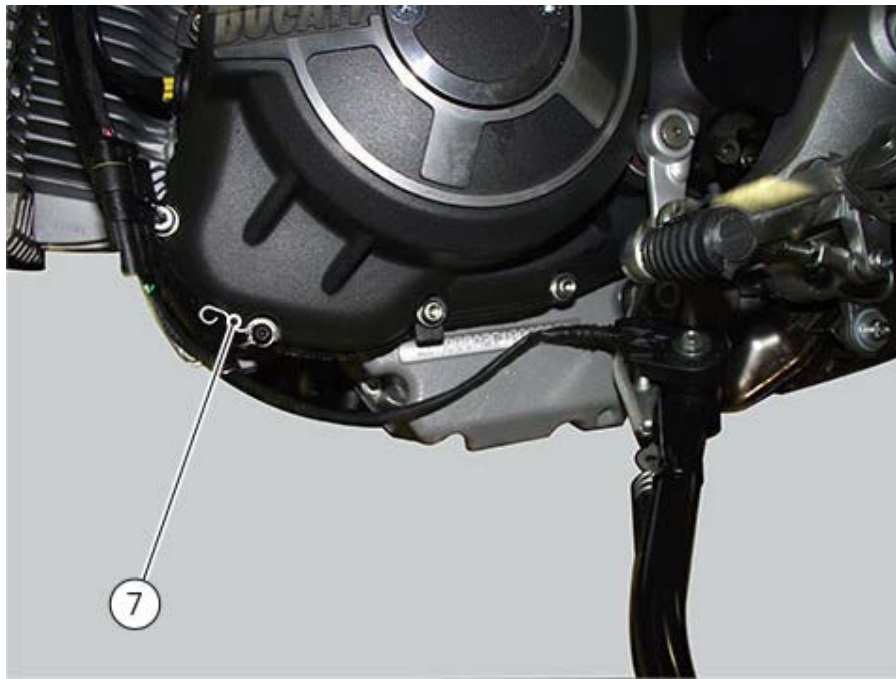

Use tool (A) no. **88713.1749** to the holes of the just-removed screws (1) and remove the cover.

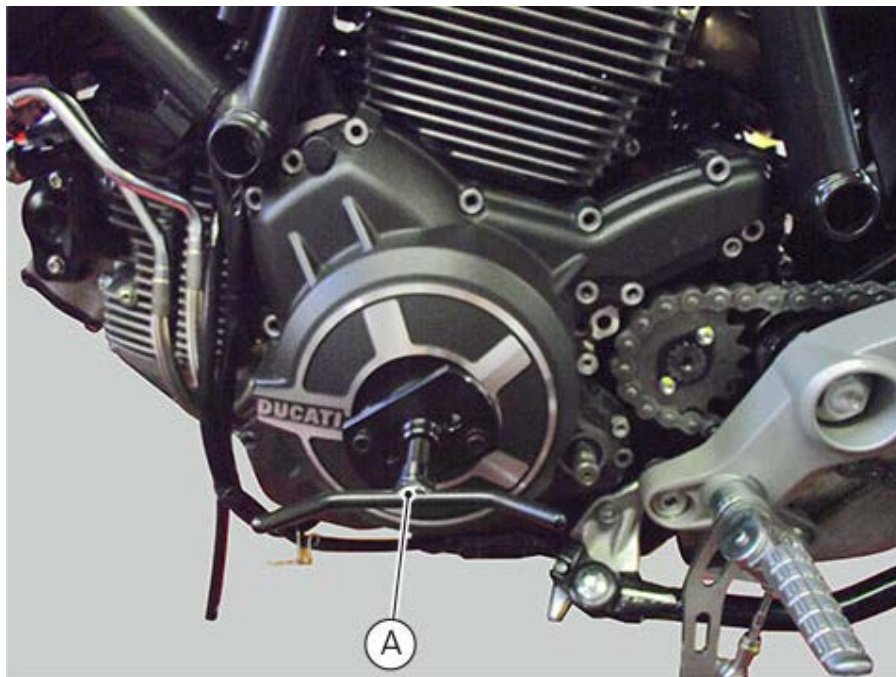

Refitting the starter motor

Start retaining screws (2) with specified threadlocker.
Tighten the screws (3) to a torque of 10 Nm (min. 9 Nm. - max. 11 Nm).

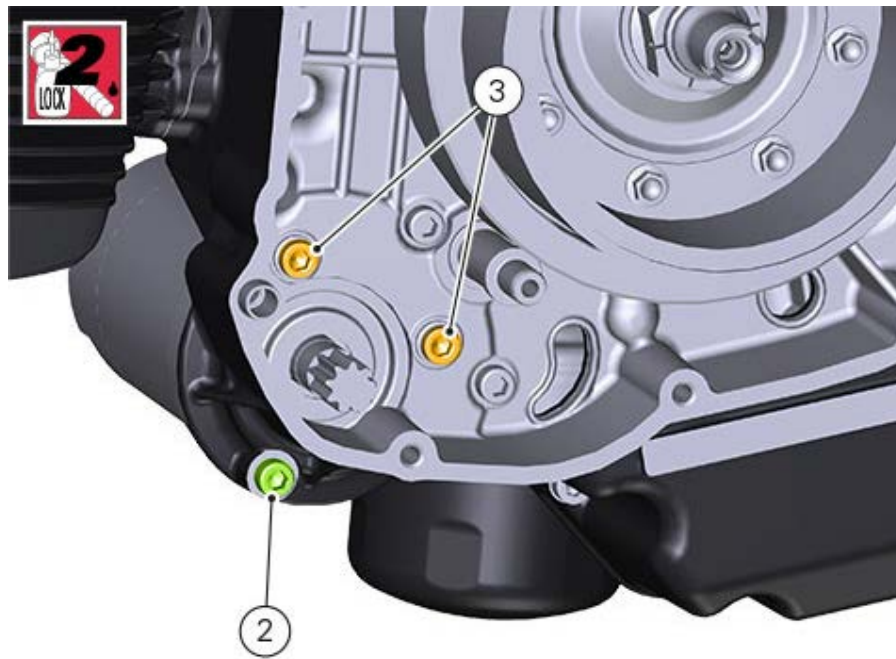

Connect the connector (1).

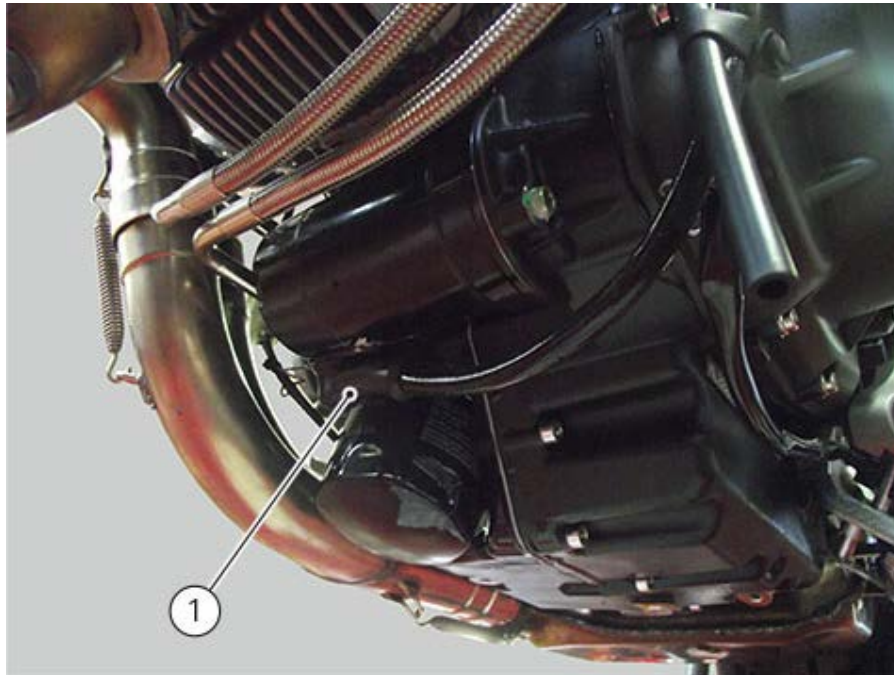

Removing the starter motor

Remove the generator cover ([Removing the generator cover](#)).

Remove starter motor connector (1).

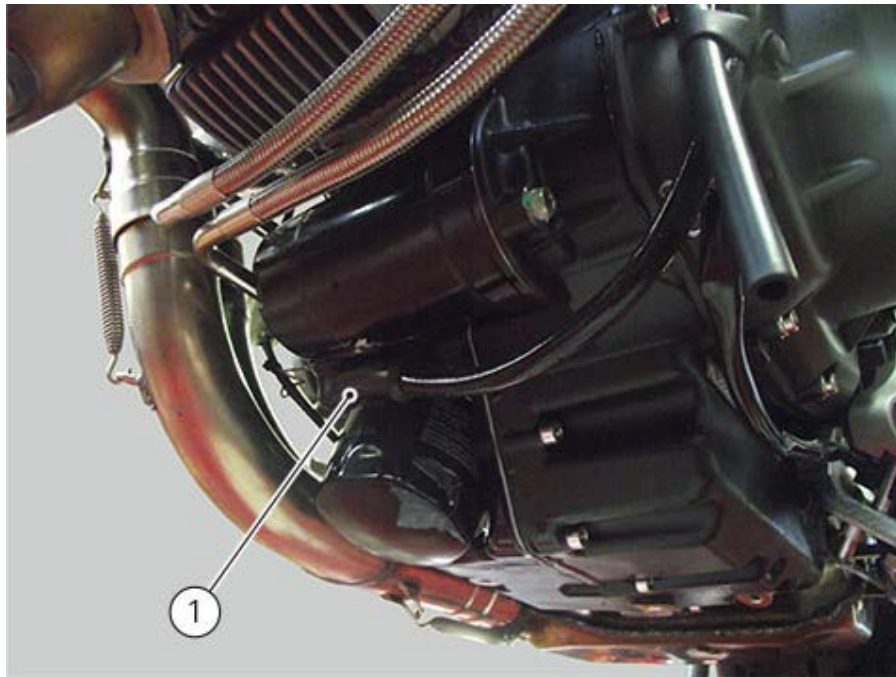

Loosen screw (3) and the two screws (2).



Remove starter motor (4).

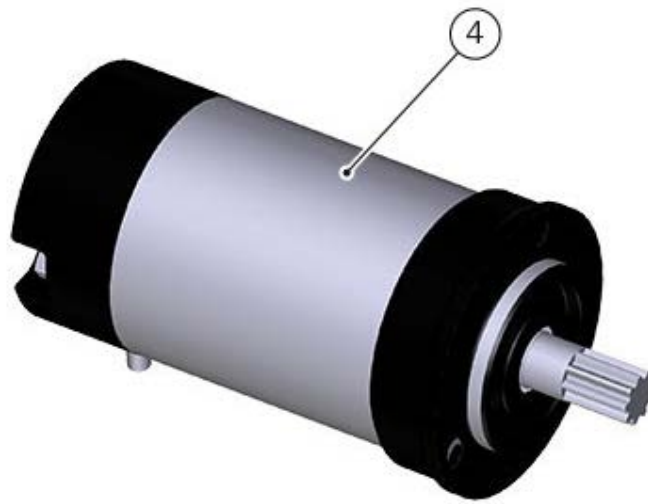

Refitting the starter motor idler gear

Refitting is the reverse of removal.

Apply indicated threadlocker to screw (5) of pin (6) and tighten it to a torque of 10 Nm (Min. 9 Nm - Max. 11 Nm).

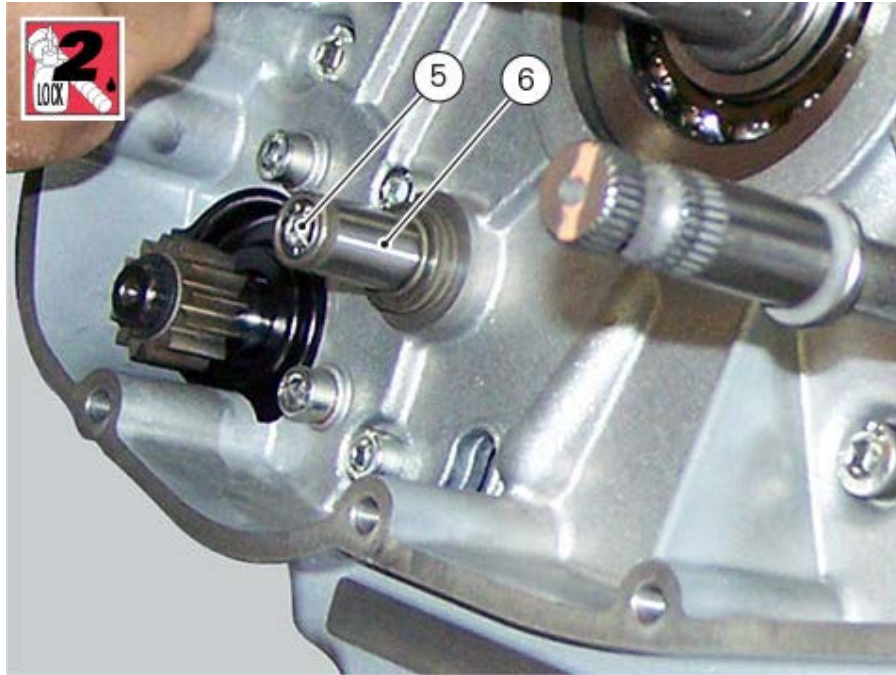

Removing the starter motor idler gear

Remove the snap ring (1) and washer (2).
Remove the starter motor idler gear (3) and washer (4).
Loosen screw (5) securing pin (6) and remove the latter.

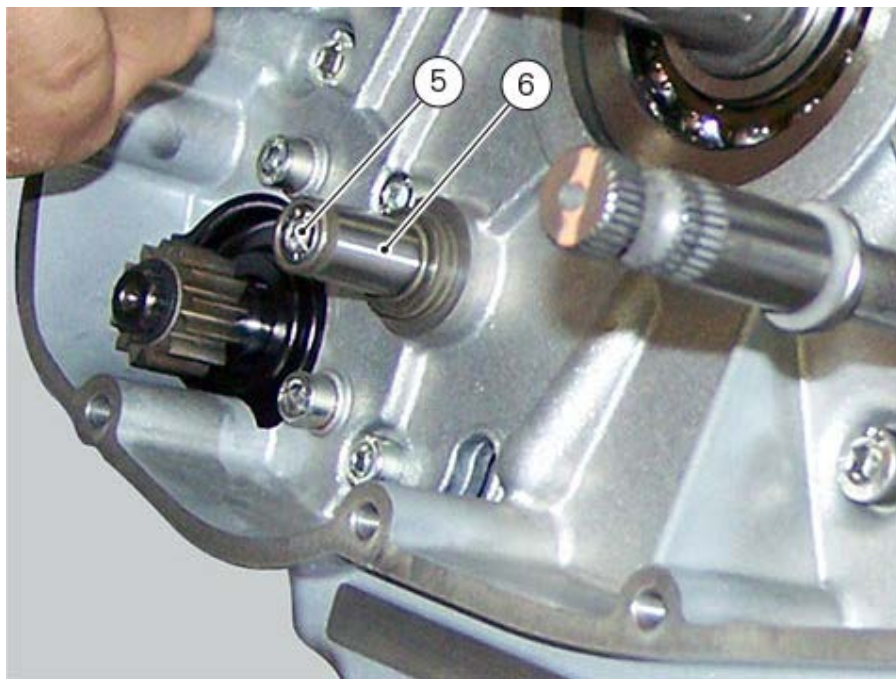
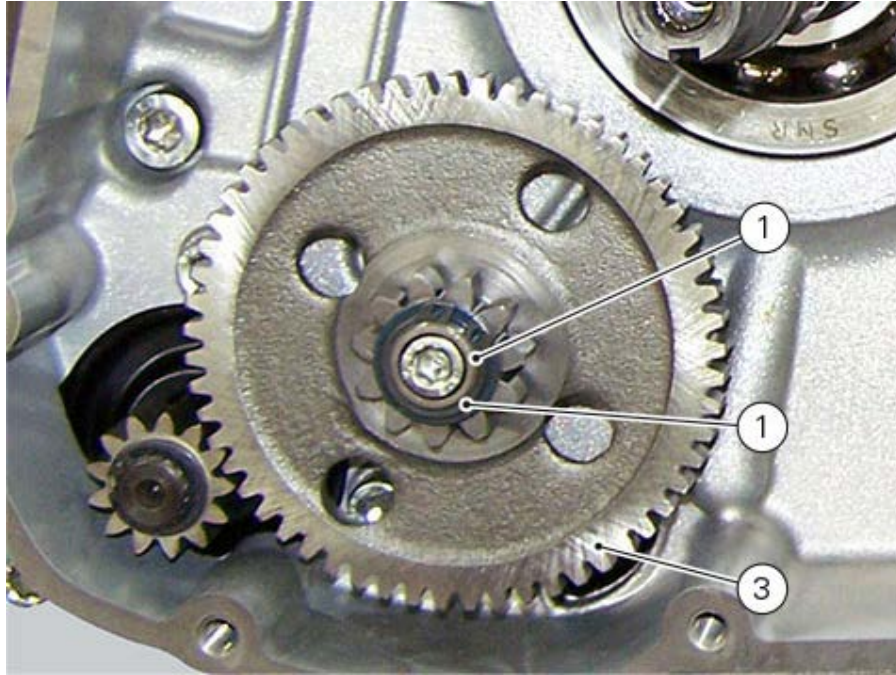

Refitting the timing gears

Important

The two timing gears must always be replaced as a pair.

Check the presence of the timing layshaft key (4) and the crankshaft key (6).

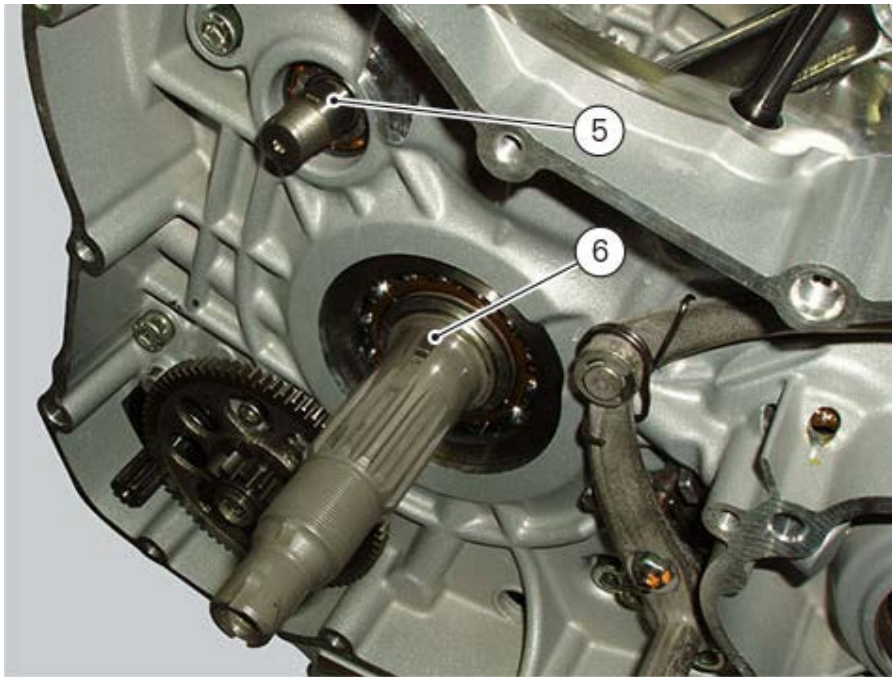

Refitting is the reverse of removal.

Align the two references of the timing layshaft gears with the camshaft reference.

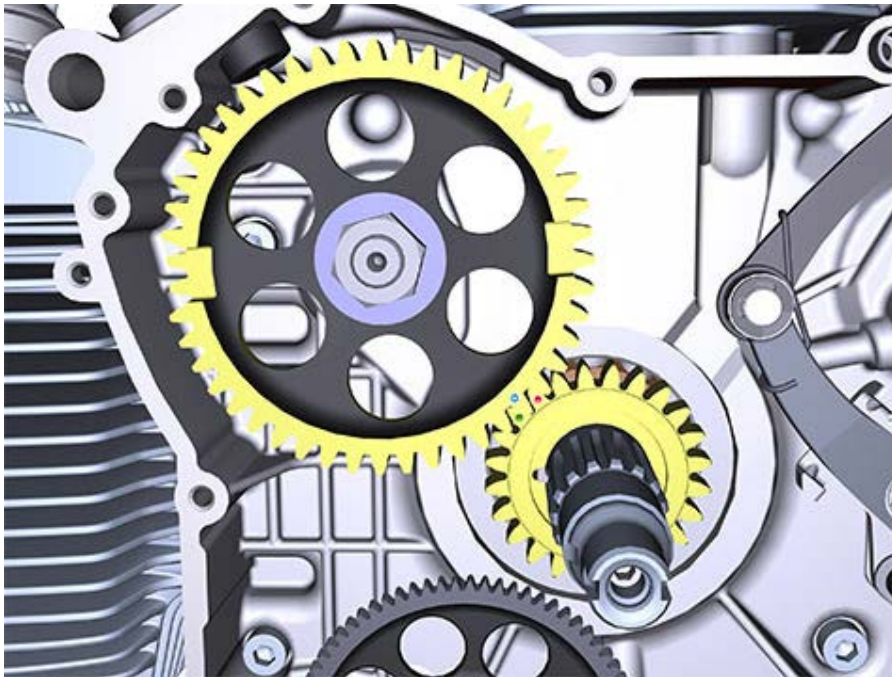

On completion of the refitting operations, check that washer (2) is staked against nut (3) in such a way to prevent the nut from working loose.

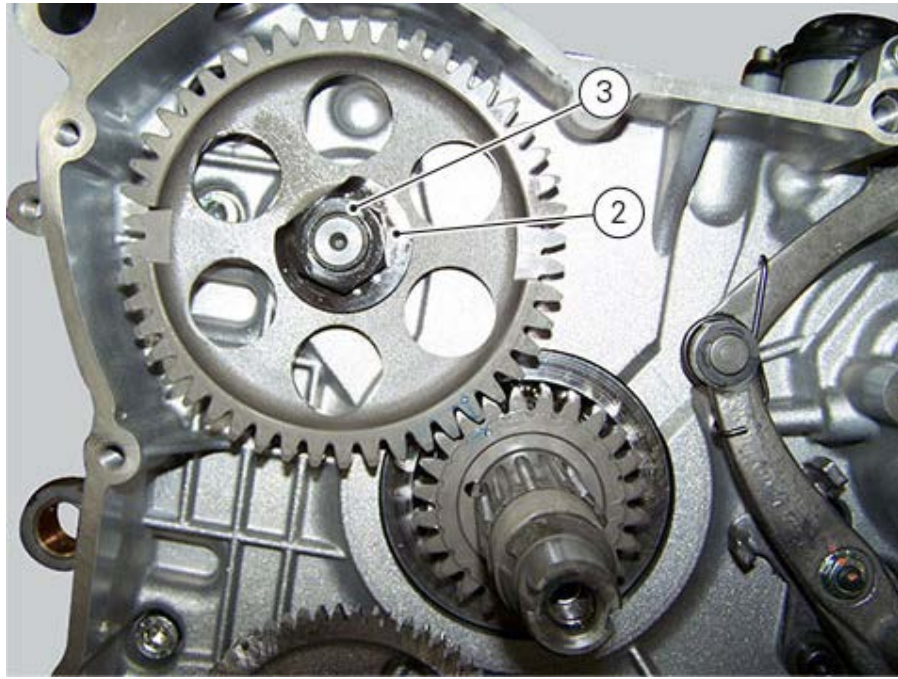

Removing the timing gears

Slide out the driving gear (1) of the timing gears.

Straighten out the lock washer (2) of timing gear lock nut (3).

Restrain the timing gear by inserting a pin in one of the holes, and unscrew the locking nut (3).

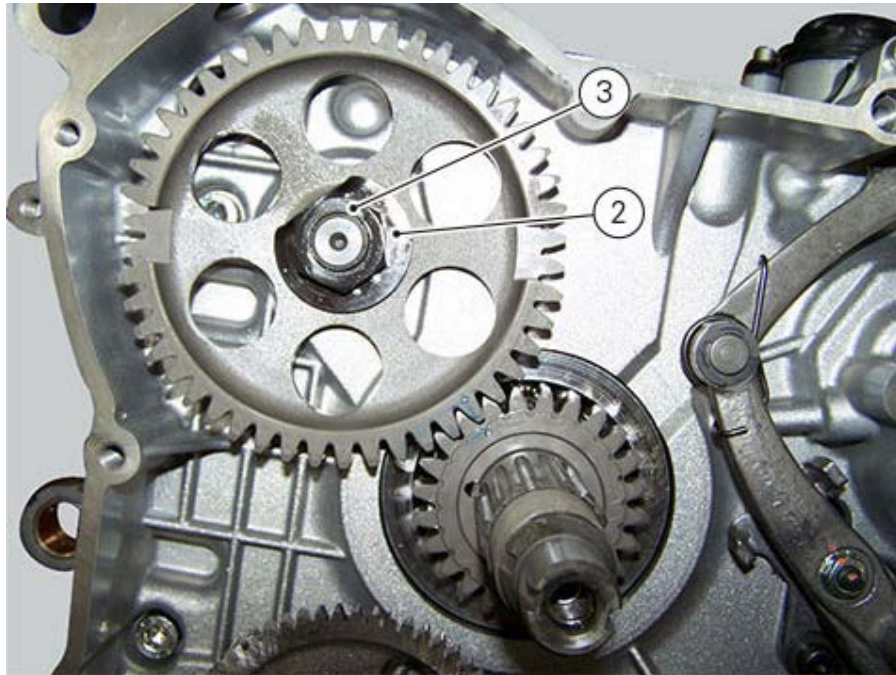

Slide out nut (3), washer (2) and driven timing gear (4).

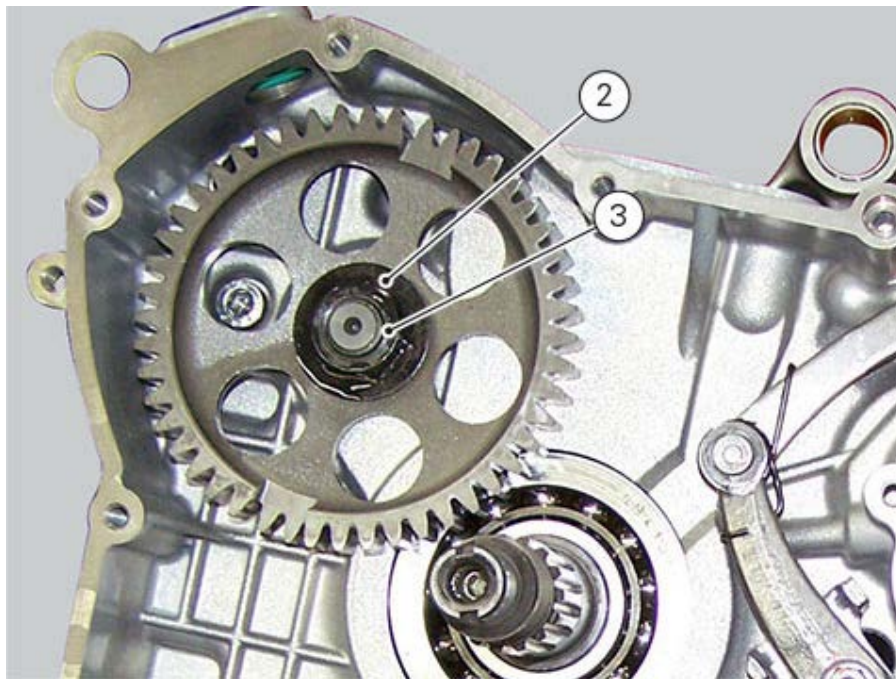

Refitting the external components

Check the condition of O-rings (3) and replace them if necessary.
Install the blow-by valve (2) in the crankcase along with O-rings (3), previously lubricated.
Tighten screw (1) to a torque of 10 Nm (Min. 9 Nm - Max. 11 Nm).

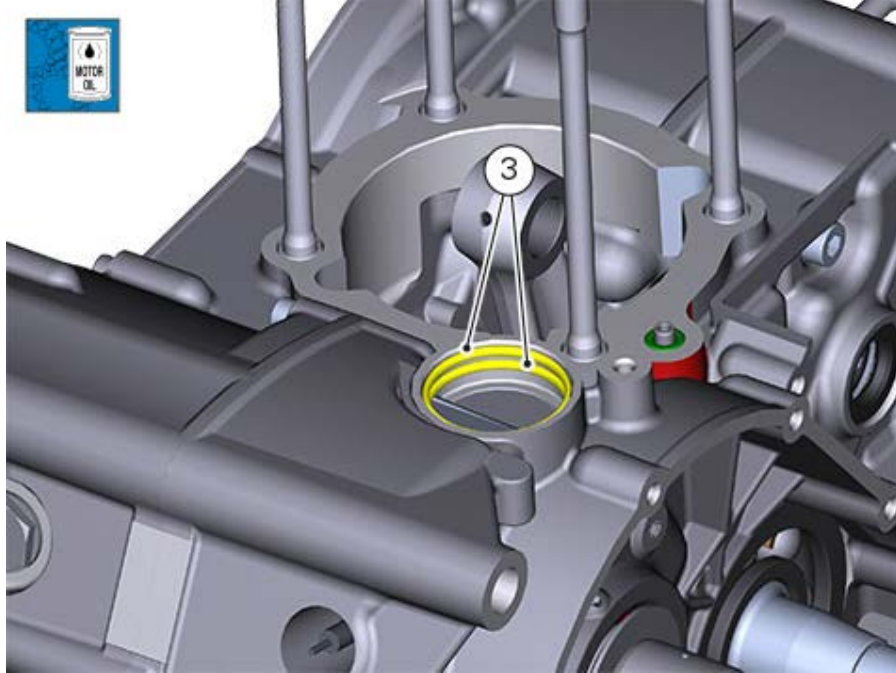

Fit nuts (5) on nipples (4).
Apply recommended threadlocker to the plug thread (4). Tighten nipples (4) to a torque of 32 Nm (Min. 29 Nm - Max. 35 Nm).

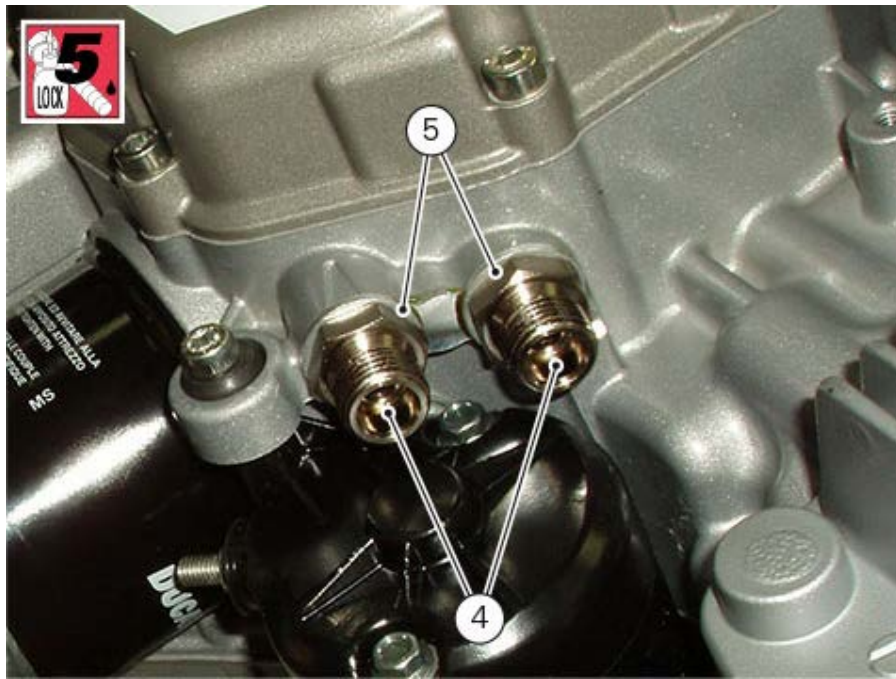

Apply the recommended threadlocker on nipple (6).
Tighten oil filter cartridge support nipple (6) to a torque of 42 Nm (Min. 38 Nm - Max. 46 Nm).

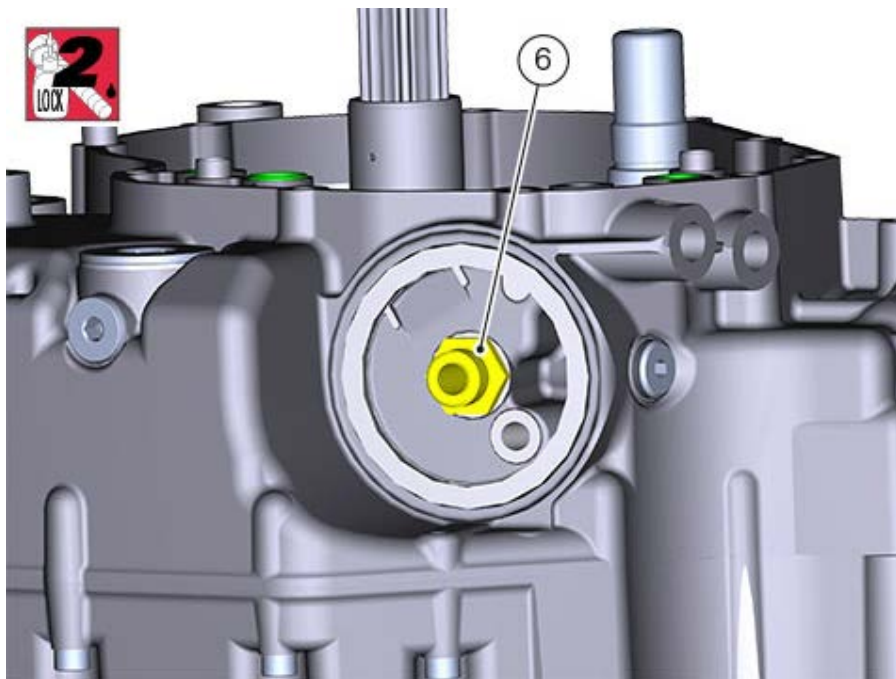

Screw the drain plug (12) with seal (13) to a torque of 20 Nm (Min. 18 Nm - Max. 22 Nm) after applying the specified product.

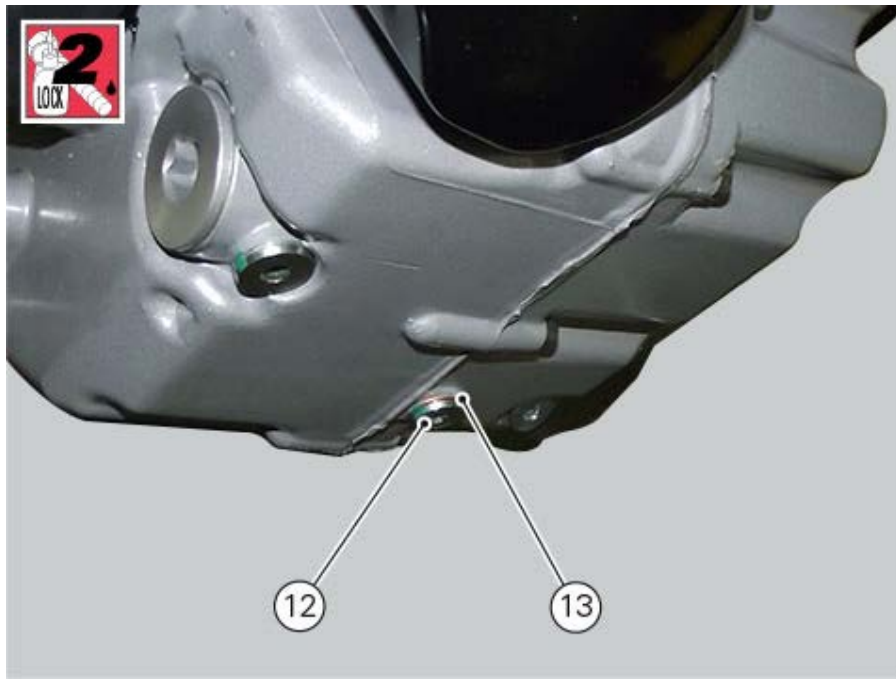

Refit the neutral switch (14) and the relevant seal (15) by tightening to a torque of 10 Nm (Min. 9 Nm - Max. 11 Nm).

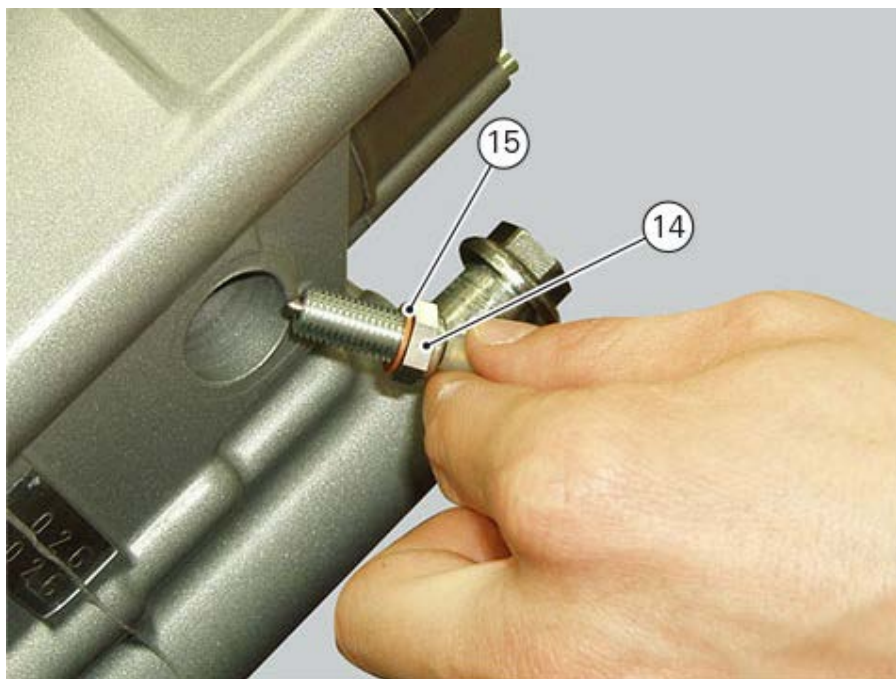

Apply threadlocker to plug (10), start it with the relevant gasket (11) and tighten the plug to a torque of 25 Nm (Min. 22 Nm - Max. 28 Nm).

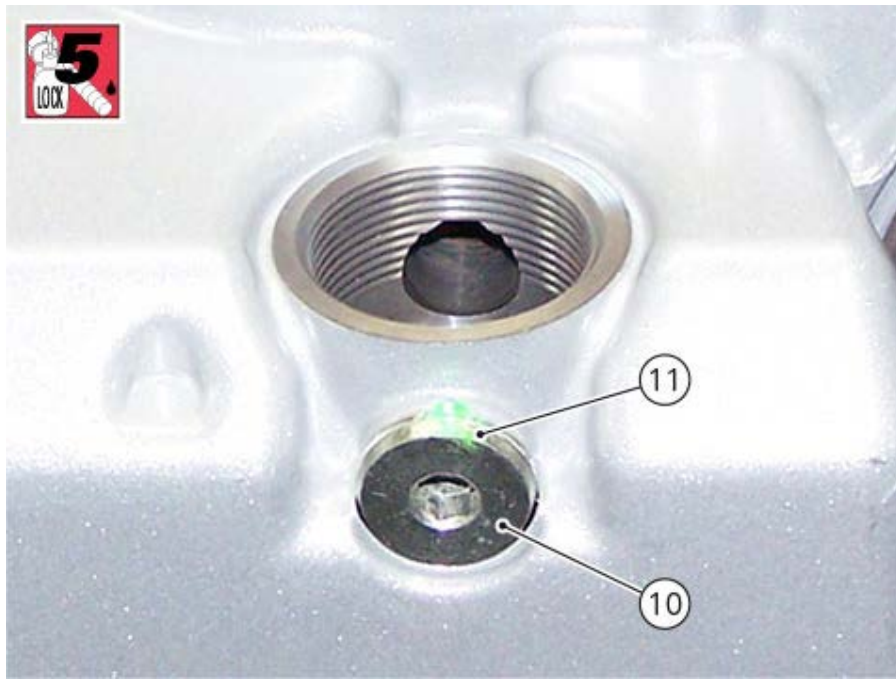

Refit the mesh filter (9).

If previously removed, refit the stud bolts (16) on the crankcase halves, applying sealant on the thread and tightening to a torque of 30 Nm (Min. 28 Nm - Max. 32 Nm).

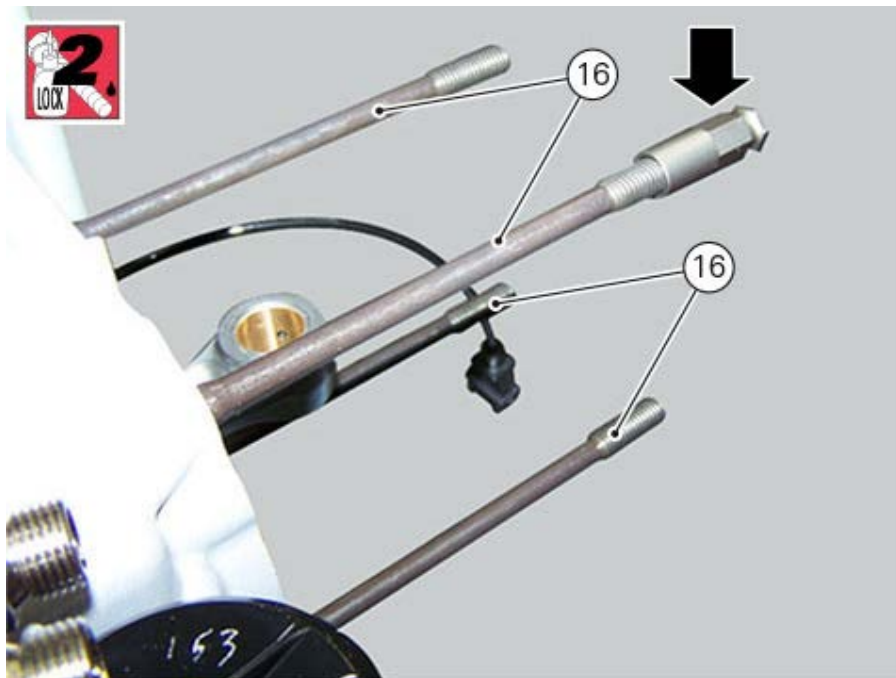

Make sure that the O-rings (20) are fitted on the crankcase.



Fit the pick-up sensor (17) in its seat in the crankcase half.
Start the screw (18) with the washer (19) and tighten to a torque of 10 Nm (Min. 9 Nm - Max. 11 Nm).

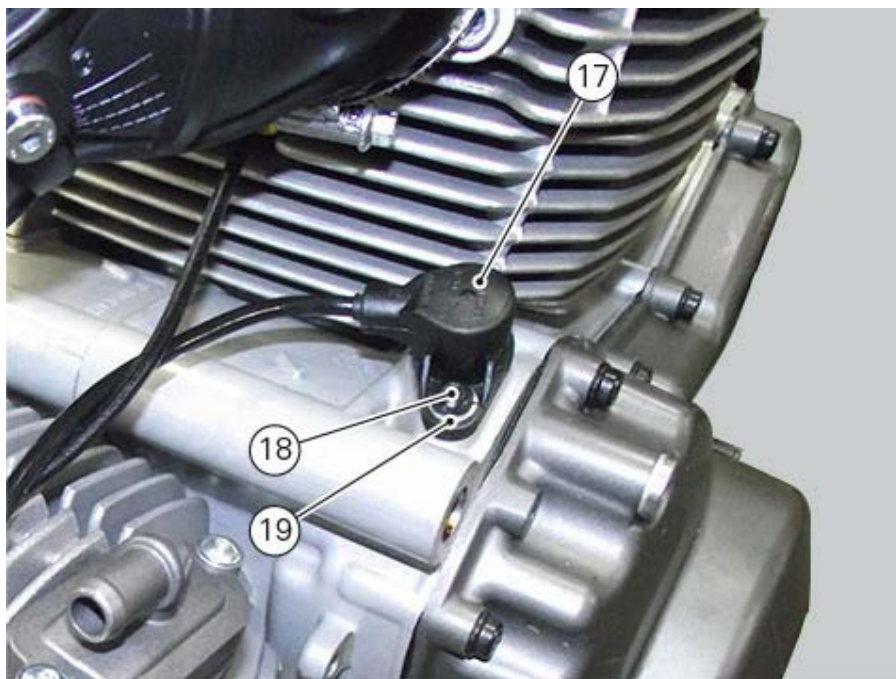

Use a feeler gauge to check the clearance between the engine sensor (17) and the timing gear (23).
The value must be between 0.6 and 0.8 mm.

Fit on the casing the ball (25), spring (26), pad (24) and tighten bush (21) with gasket (22) to a torque of 10 Nm (Min. 9 Nm - Max. 11 Nm).

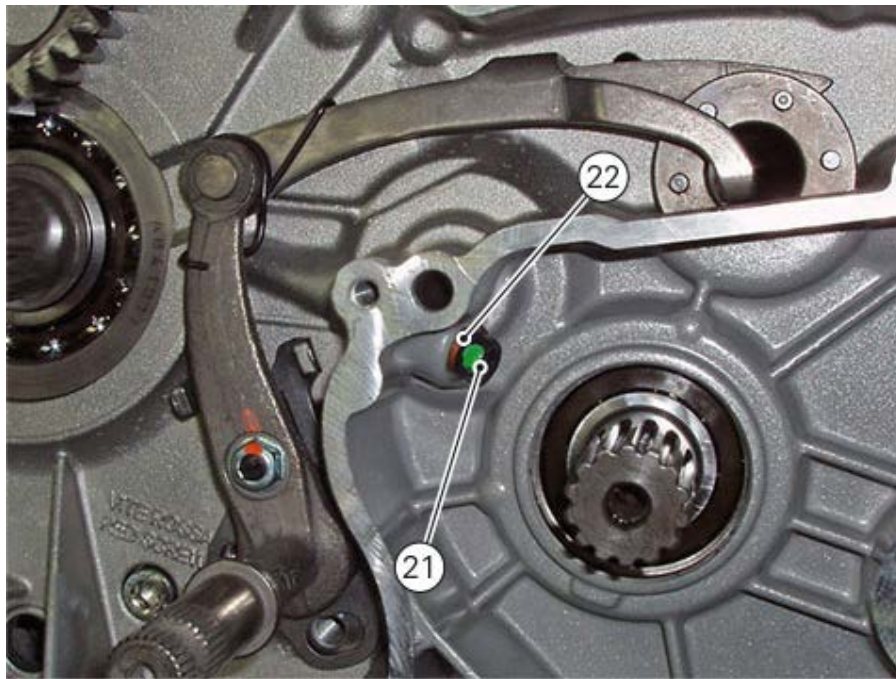
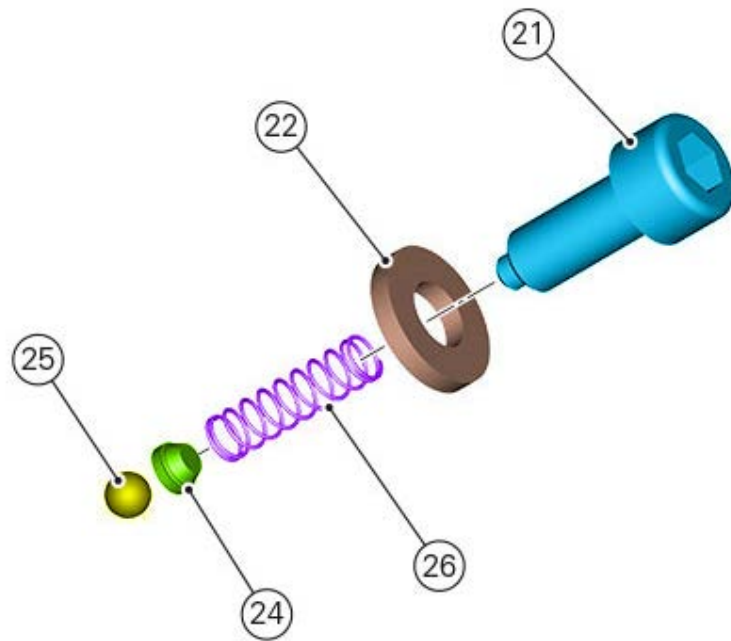

- Refit the cylinder/piston assembly ([Refitting the cylinder/piston assembly](#)).
- Refit the cylinder heads ([Refitting the cylinder heads](#)).
- Refit the generator cover ([Refitting the generator cover](#)).
- Refit the oil pump ([Refitting the oil pump](#)).
- Refit the clutch cover ([Refitting the clutch cover](#)).
- Refit the engine in the frame ([Refitting the engine](#)).

Removing outer components

Remove the engine from the frame ([Removing the engine](#)).

Remove the clutch cover ([Removing the clutch cover](#)).

Remove the complete clutch unit ([Removing the clutch](#)).

Remove the oil pump ([Removing the oil pump](#)).

Remove the generator cover ([Removing the generator cover](#)).

Remove the heads ([Removing the engine heads](#)).

Remove the cylinder ([Removing the cylinder/piston assembly](#)).

Undo screw (1) and remove the blow-by valve (2) from the engine.

Check the condition of the O-rings (3) located in the casing and replace them if necessary.

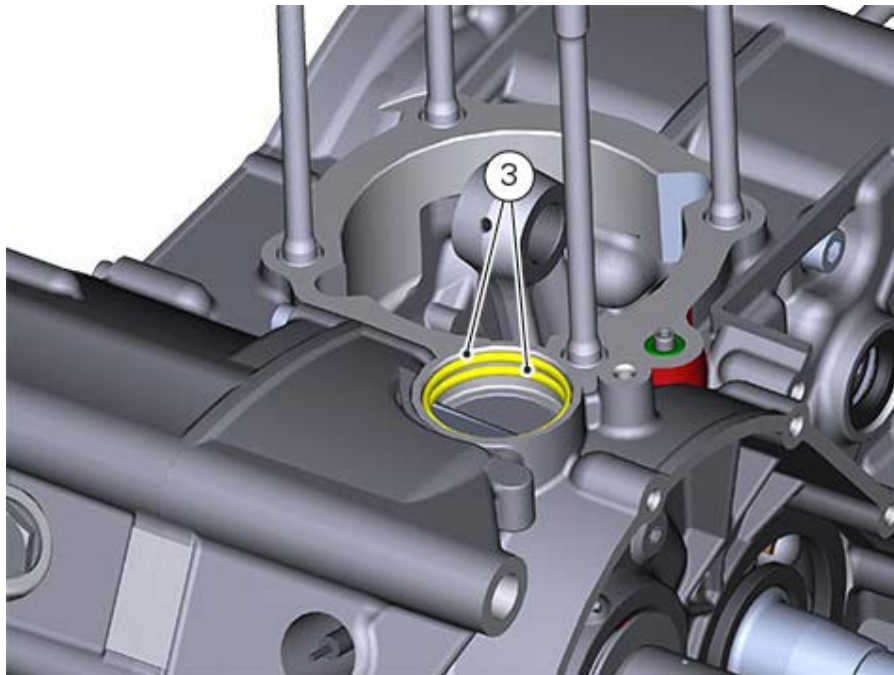

Loosen and remove the two nipples (4) from the clutch crankcase half and collect washers (5).

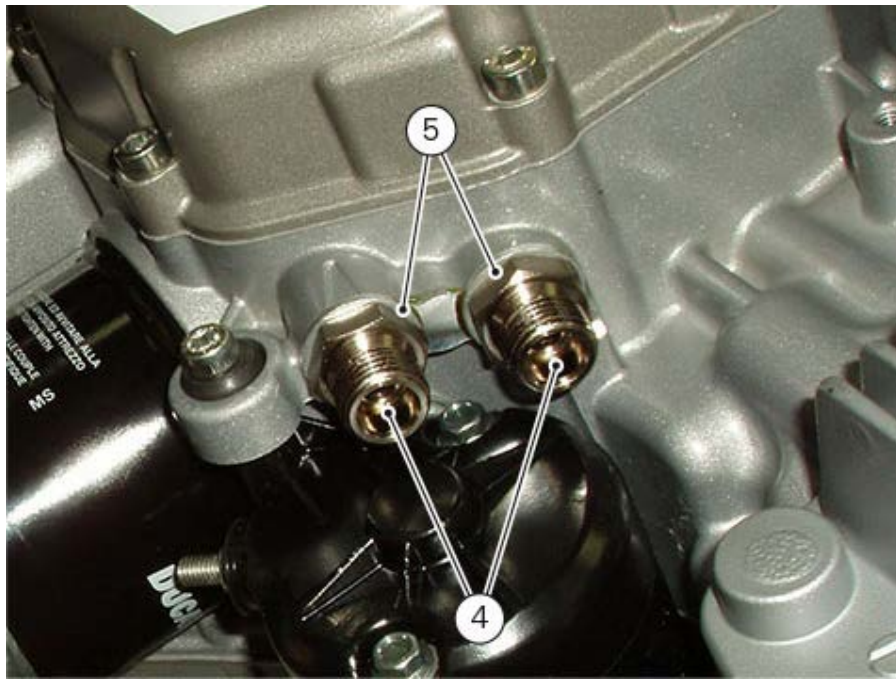

Loosen and remove the oil filter cartridge.
Loosen and remove oil filter supporting nipple (6).

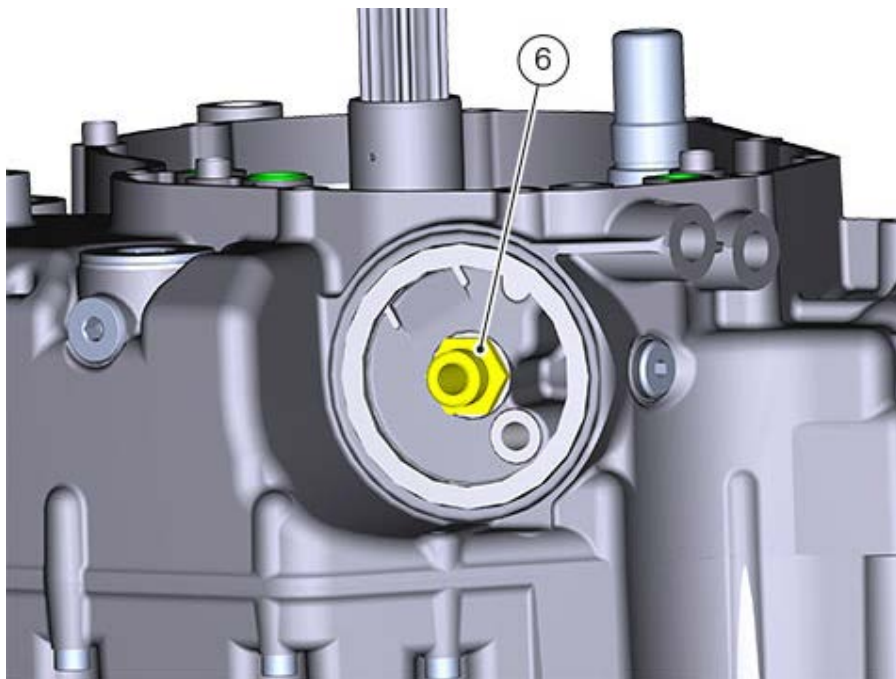

Loosen plug (7) and remove seal (8).
Remove the mesh filter (9) from the clutch-side crankcase half.

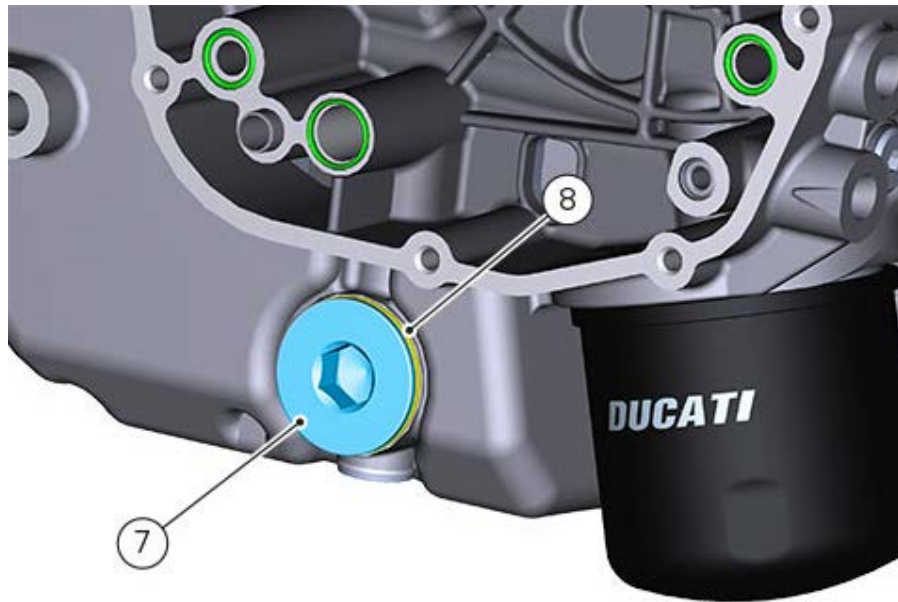

Loosen plug (10), taking care not to damage seal (11).

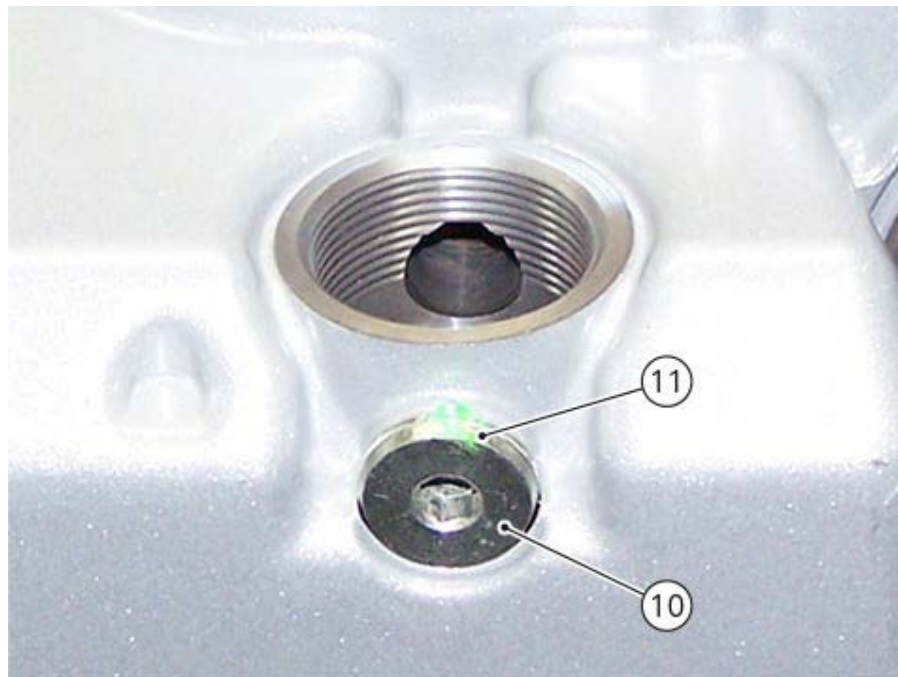

Remove the drain plug (12) with its seal (13).

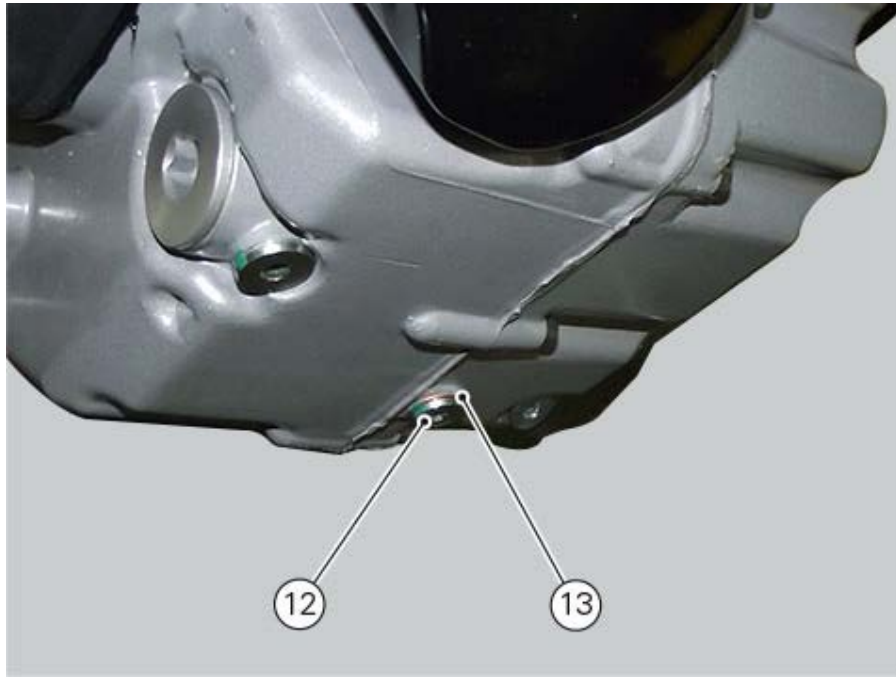

Remove the neutral switch (14) and the relevant seal (15).

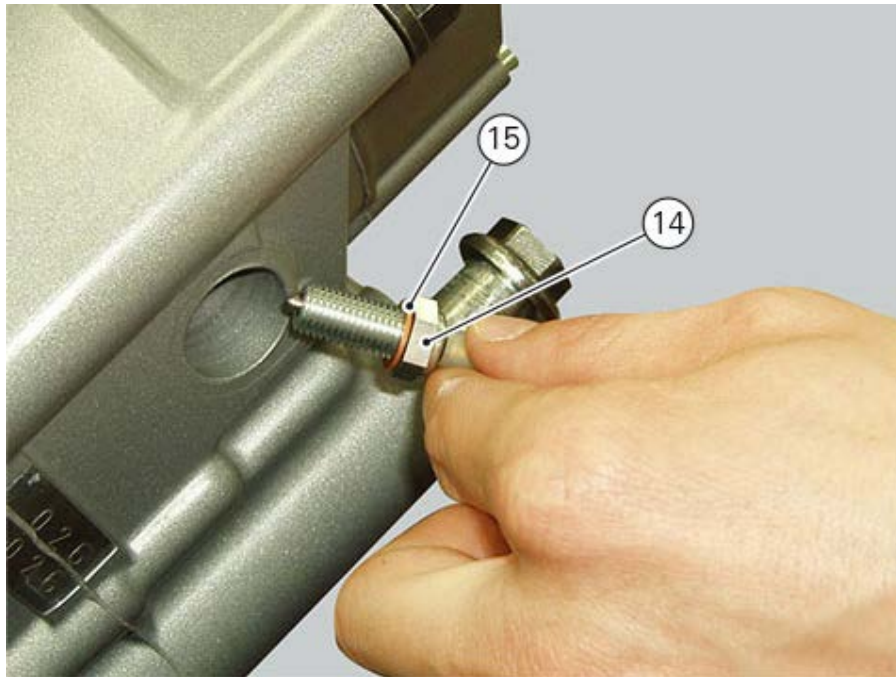

Remove the cylinder head stud bolts (16) with the aid of the appropriate tool.

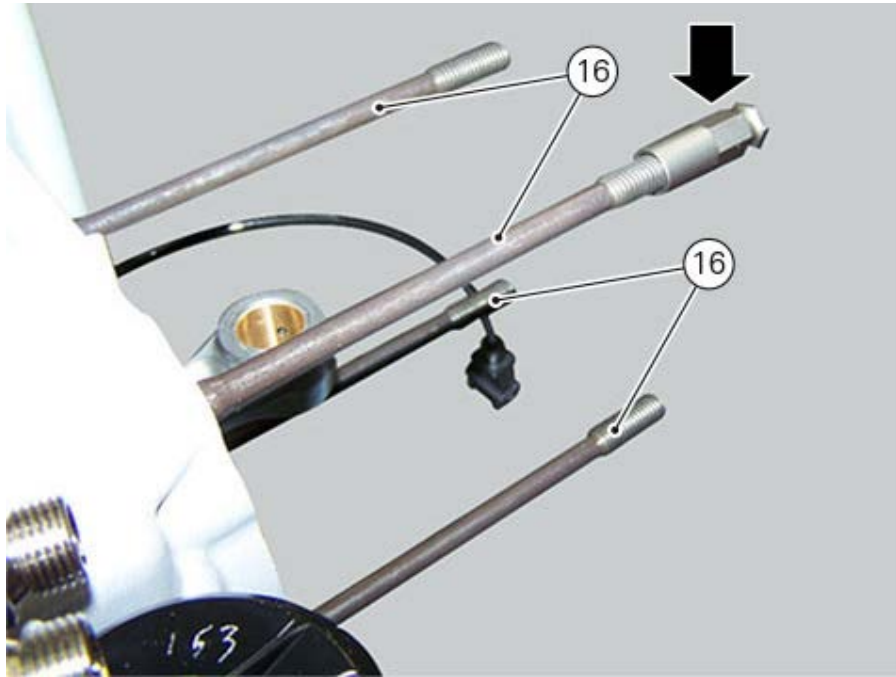

To remove the engine sensor (17), undo the screw (18) and collect the washer (19).

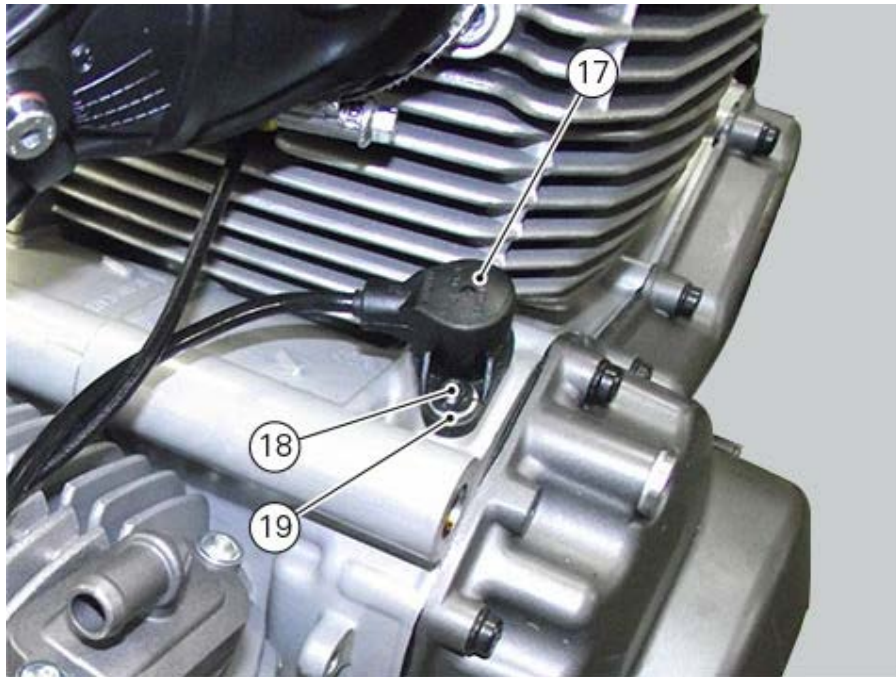

Check the condition of O-rings (20) on the crankcase half and replace them if necessary.



Closing the crankcase

If previously removed, apply specified threadlocker to dowel (28) and tighten to a torque of 15 Nm (Min. 13 Nm - Max. 17 Nm).

After tightening, remove the excess of threadlocker.

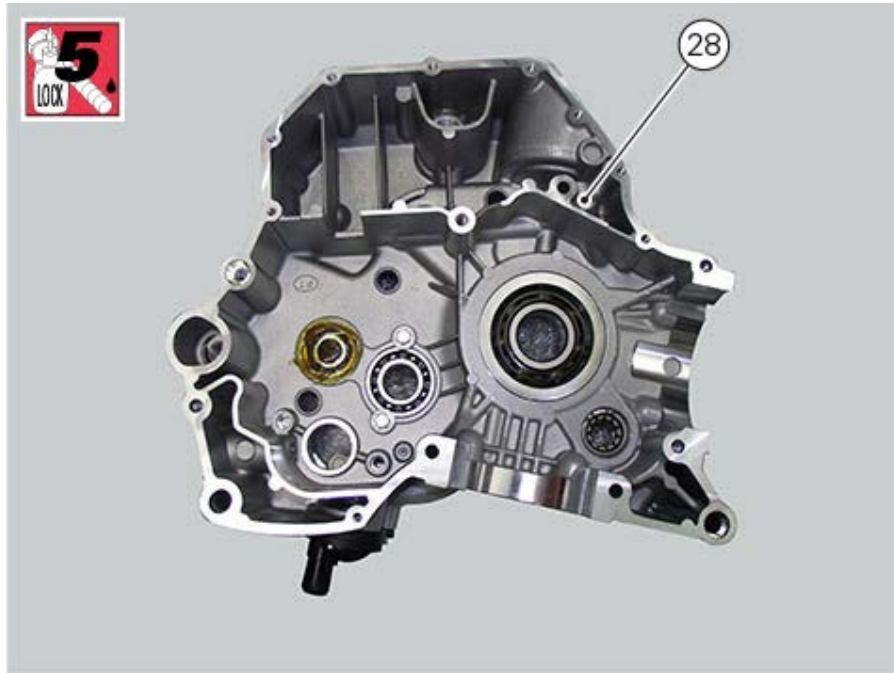

Install the timing layshaft (2) in the roller bearing (29) on the clutch-side crankcase half.

To avoid damaging the sealing ring (23) on the timing layshaft, protect the threaded end of the shaft with the special protective cap part no. **88700.5749**.

Dampen sealing ring (23) with alcohol and fit it on the timing layshaft. Push seal until it contacts the roller bearing (29).

Fit the snap ring (1) in the groove on the shaft and remove the protective cap.

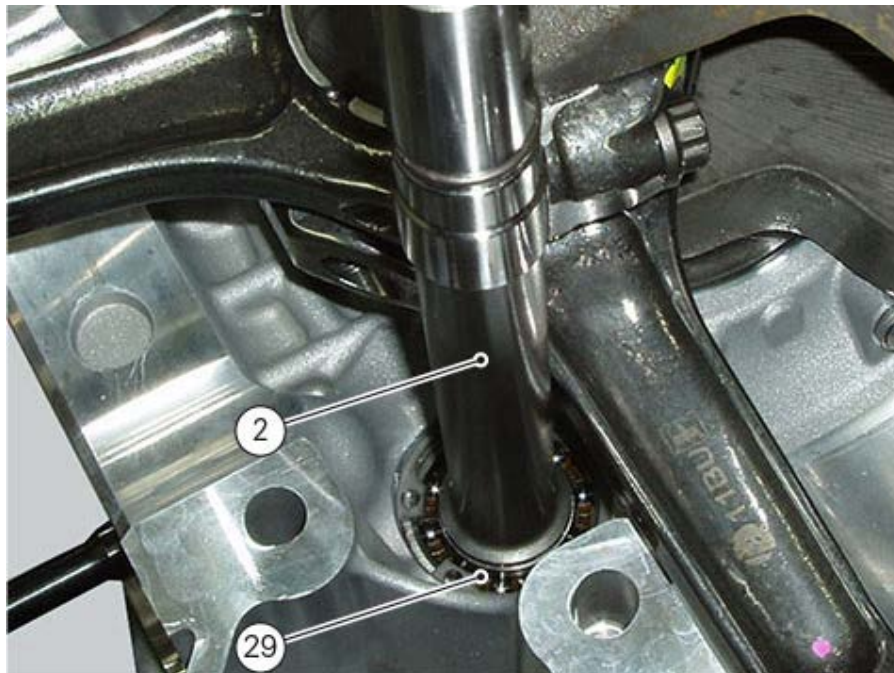

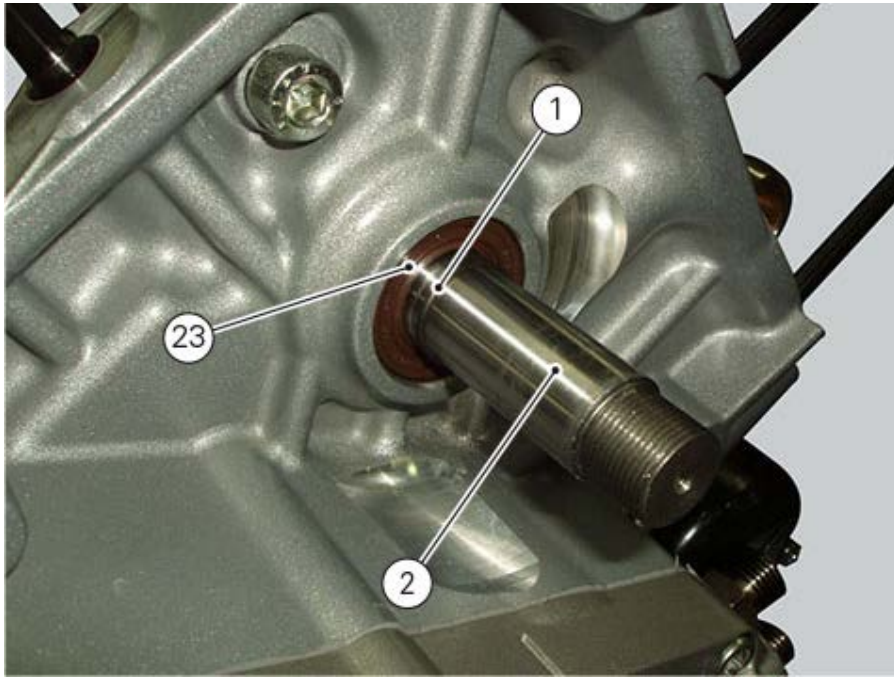

Note

When refitting used components, before installing the gearbox assembly in the crankcase half, make sure that the inner races of the gearbox shaft end bearings are fitted into the correct bearings and have not been left on the shafts.



Match gearbox shafts, fit the calculated shims and fit them to the clutch-side crankcase half.

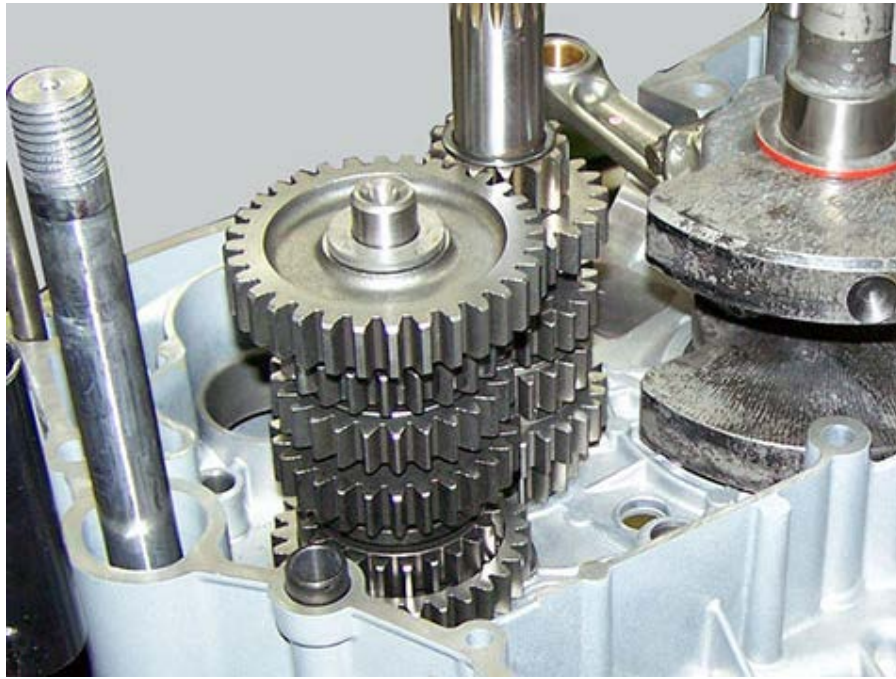

Insert the forks of 1st - 4th and 2nd - 3rd speed (38) inside the sliding grooves of the secondary shaft driven gears.

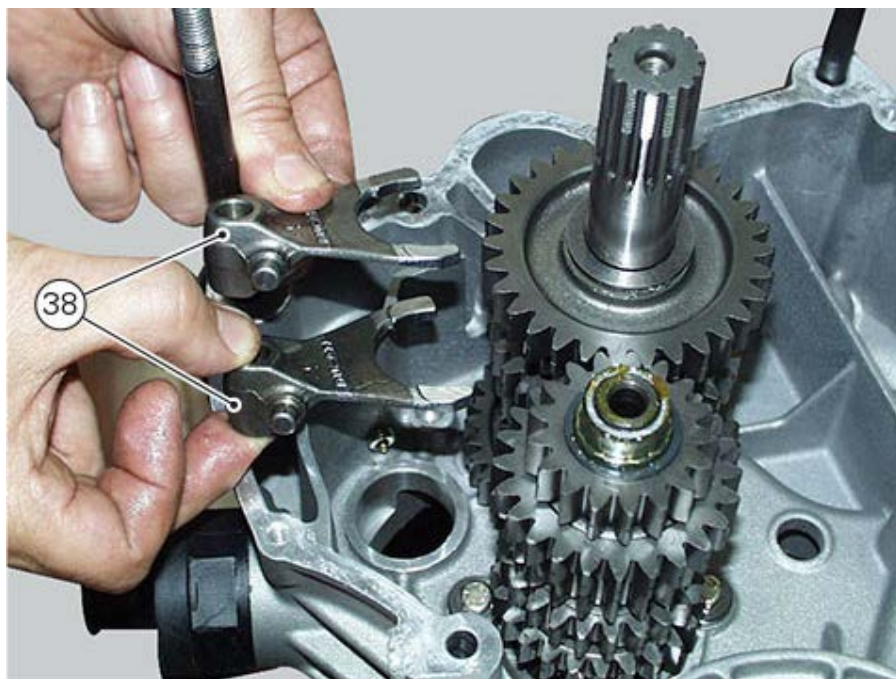

Insert the fork of 5th - 6th speed (39) inside the primary shaft driven gear.

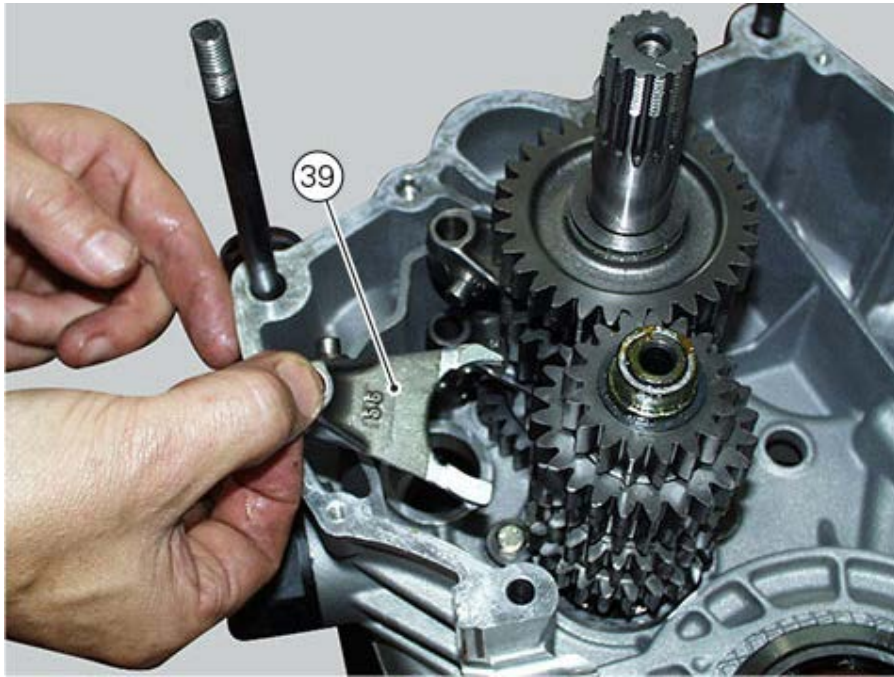

Fit the fork selector drum (40) with the calculated shims on crankcase half.

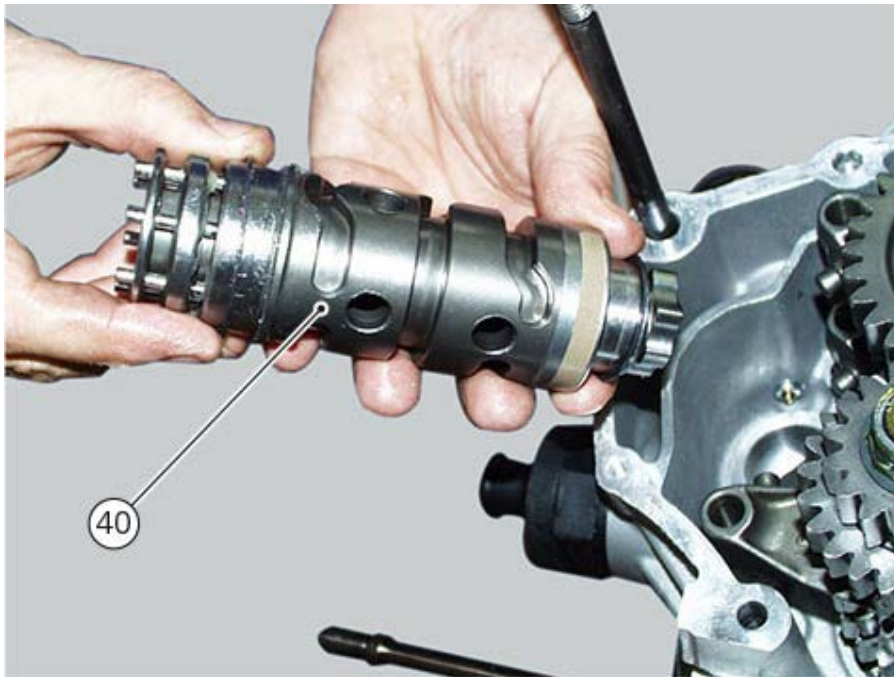

Install pins (41) in the previously installed forks.

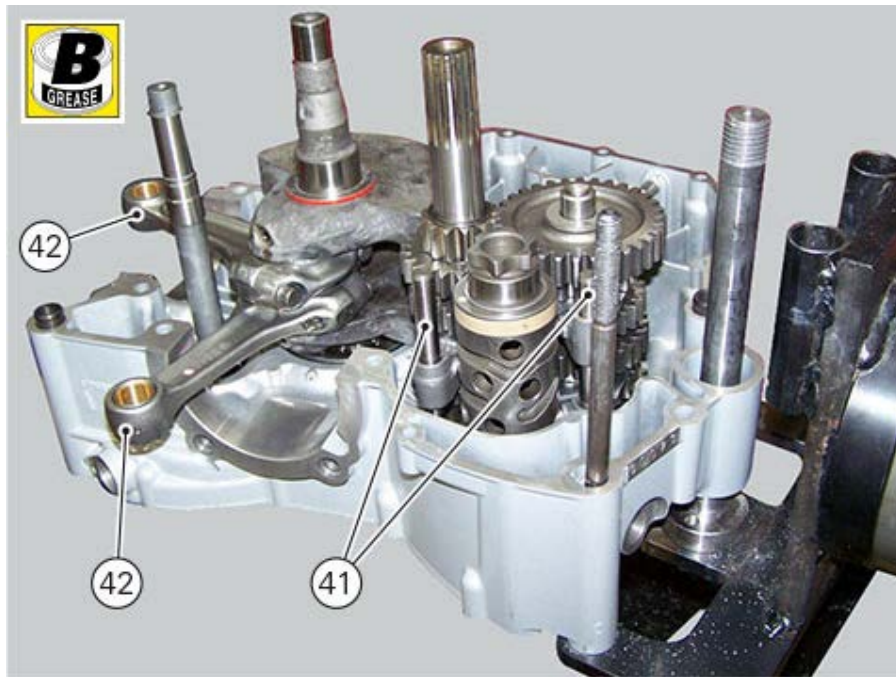

Fit crankshaft with the specially calculated shims inside clutch side crankcase half bearing, positioning connecting rods (42) in the relevant seats of the cylinders.
Check that the two centring bushes (43) are correctly fitted.
After having duly greased it to hold it in position, install the O-ring (8) on the oil channel, between the two crankcase halves.

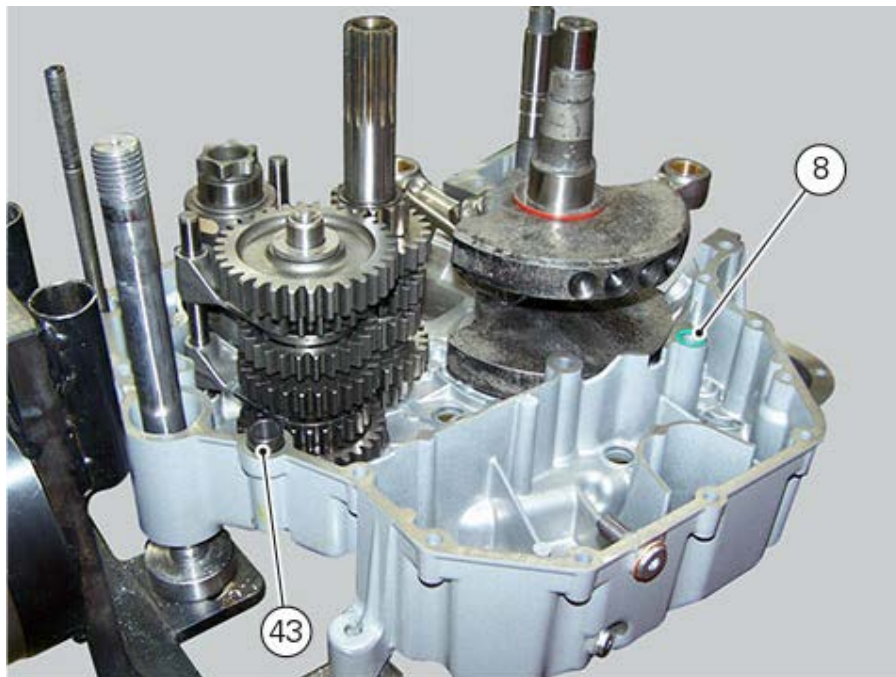

Apply an even and continuous bead of DUCATI sealing compound to the mating surface of the crankcase halves, going around all the holes as shown in the figure.

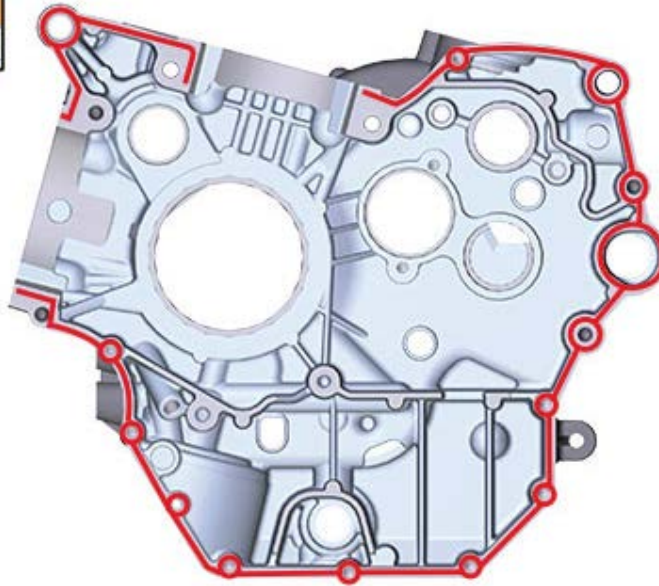

Bring the crankcase halves (44) and (45) together, tapping with a rubber mallet in the area of the shafts if necessary.

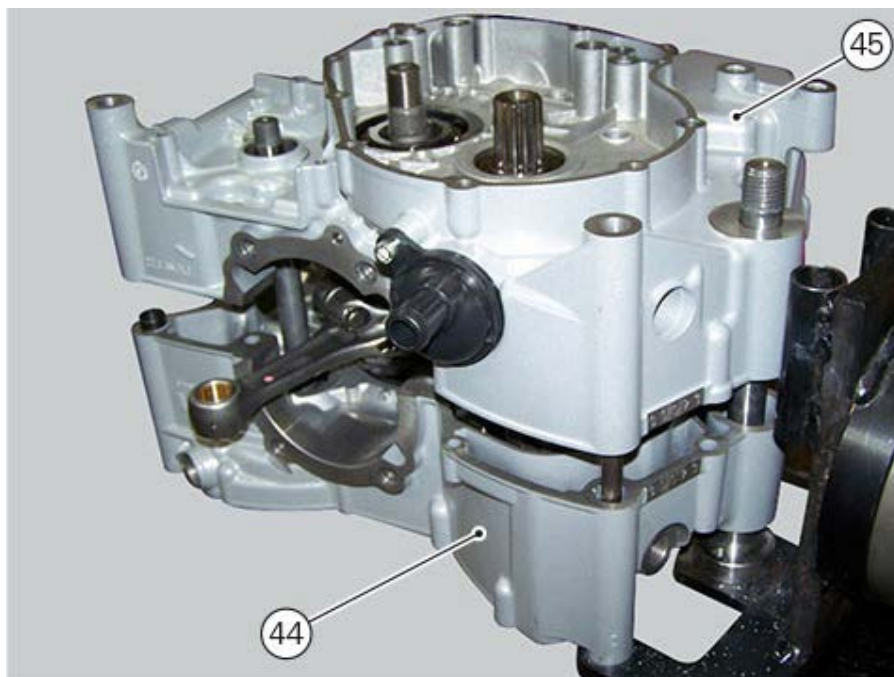

Start screws (3), (4) and (5) on the generator-side crankcase half, paying attention to the different lengths.

Start and progressively drive fully home the jointing screws starting with those with a larger diameter (M8). Install two M8 screws (3) on the clutch side crankcase half.

Tighten all screws to the indicated torque:

- screws (8) first to a snug torque of 19 Nm (Min. 17 Nm - Max. 21 Nm), then to a tightening torque of 25 Nm (Min. 22 Nm - Max. 28 Nm);
- screws (4) and (5) to a torque of 10 Nm (Min. 9 Nm - Max. 11 Nm).

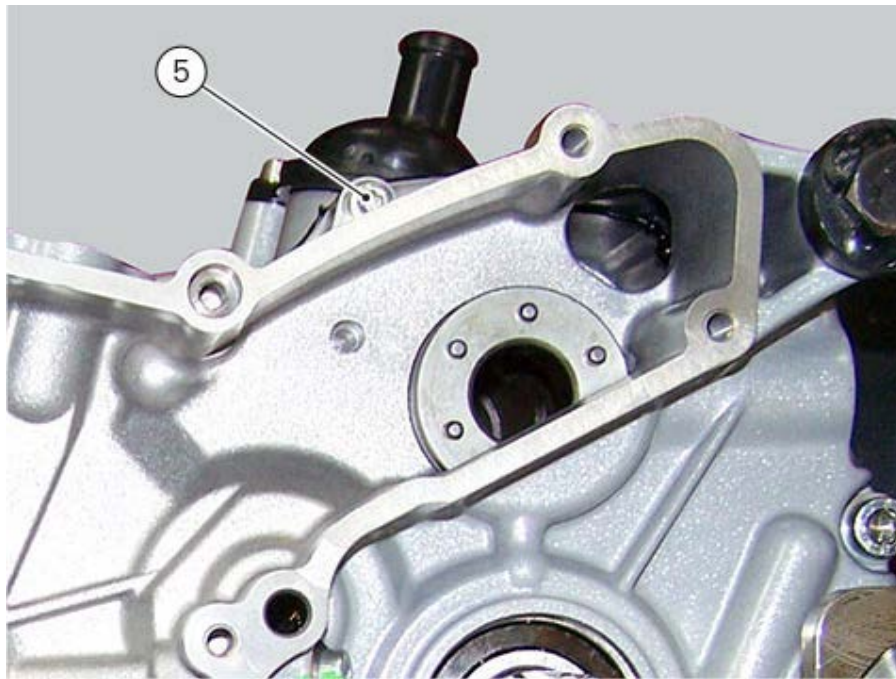
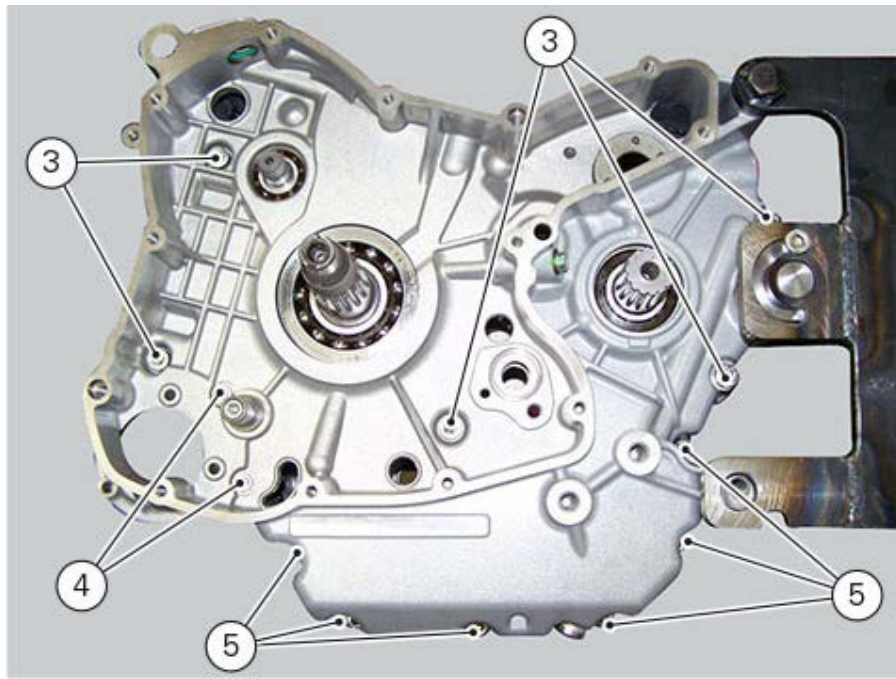

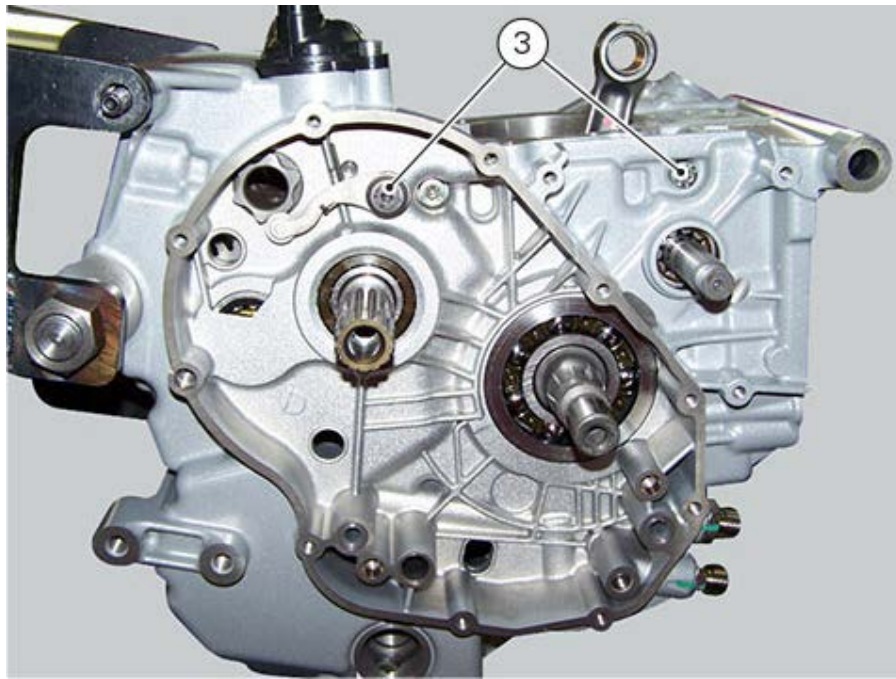

- Refit the complete cylinder/piston assembly ([Refitting the cylinder/piston assembly](#)).
- Refit the complete cylinder head assembly ([Refitting the cylinder heads](#)).
- Refit the flywheel/generator assembly ([Refitting the flywheel/generator assembly](#)).
- Refit the oil pump ([Refitting the oil pump](#)).
- Refit the engine in the frame ([Refitting the engine](#)).

Shimming the shafts

Before assembling the crankcase halves, it is necessary to calculate the shim that determines the end float of the crankshaft and of the gearbox shafts. Calculate the shimming following the procedures described below.

Shimming the crankshaft

After having installed the new main bearings proceed as follows to determine the total "SA" height of the shimming:

Measure value "LA" between the bearing supporting surfaces on the crankshaft;

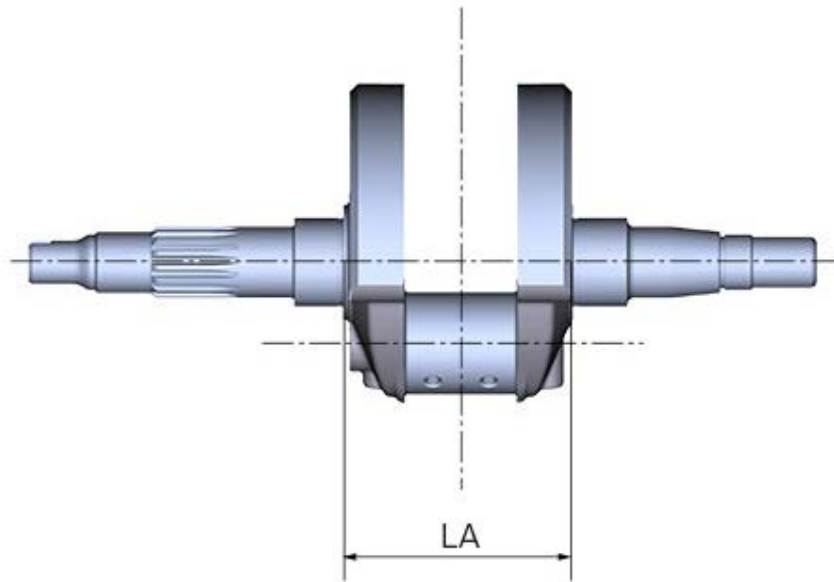

Measure "LA1" and "LA2" corresponding to the distance from the mating surface between the crankcase halves to the mating surface of the bearing inner ring;

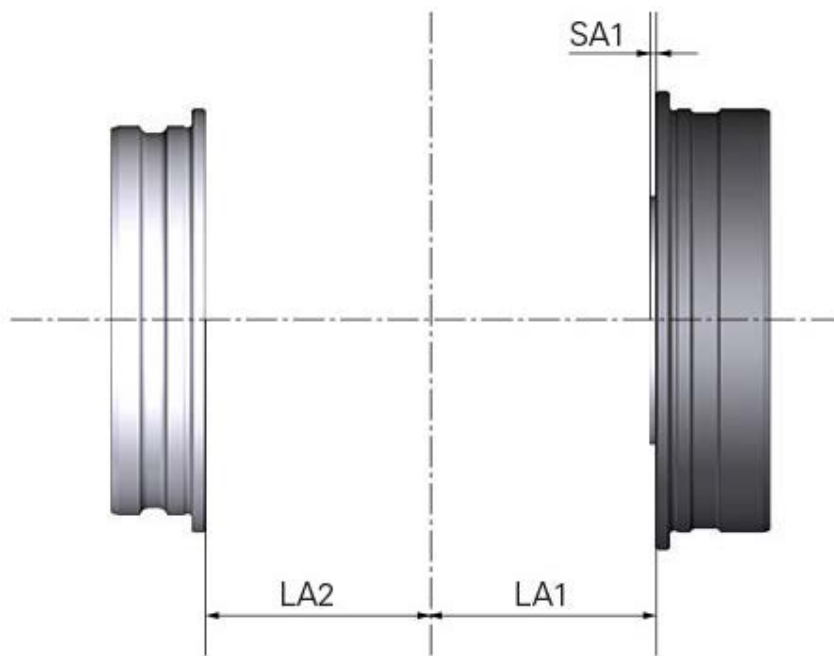

Add a pre-load of 0.30 mm to allow the axial-type bearings of the crankshaft to correctly settle in their seat.

The result will be: $SA = LA - LA1 - LA2 - 0.30$.

The obtained result is the shimming value.

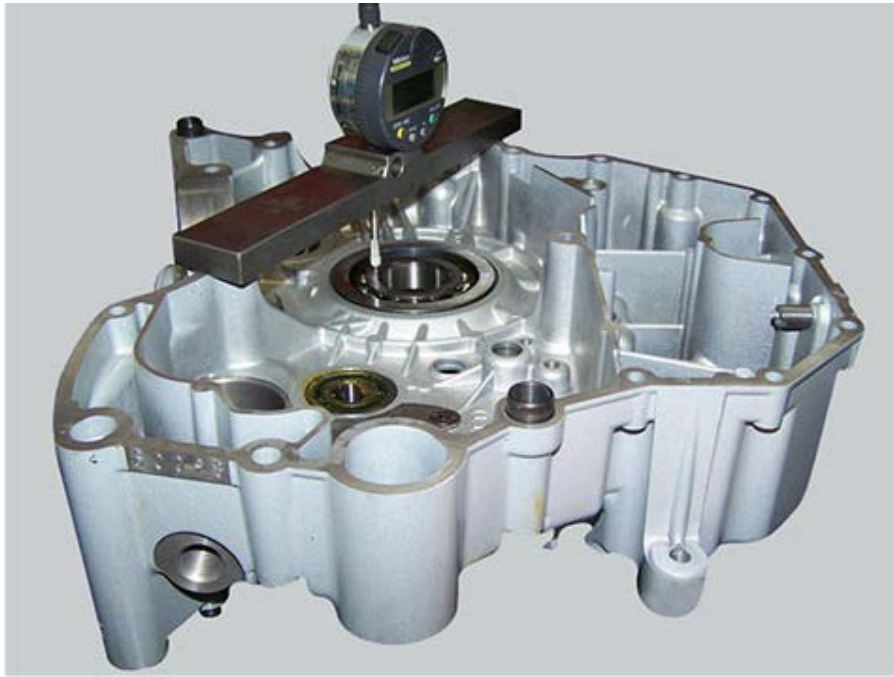

Reassembling the crankcase halves

The crankcase halves must be in good condition and perfectly clean. The mating surfaces must be perfectly flat and free from burrs.

Refitting the clutch-side crankcase half

The following parts must be present on the internal side of the crankcase half:

- the secondary shaft end bearing (12); apply grease on the bearing rollers. Drive the inner race (34), removed previously, fully home in the bearing. Apply grease to the inner race;
- the primary shaft bearing (13), secured with the screws (19) and the retaining spacer (17); apply recommended threadlocker to the screws (19), and tighten to a torque of 10 Nm (Min. 9 Nm - Max. 11 Nm);
- the roller bearing (16) with circlip (35) installed at the timing layshaft.

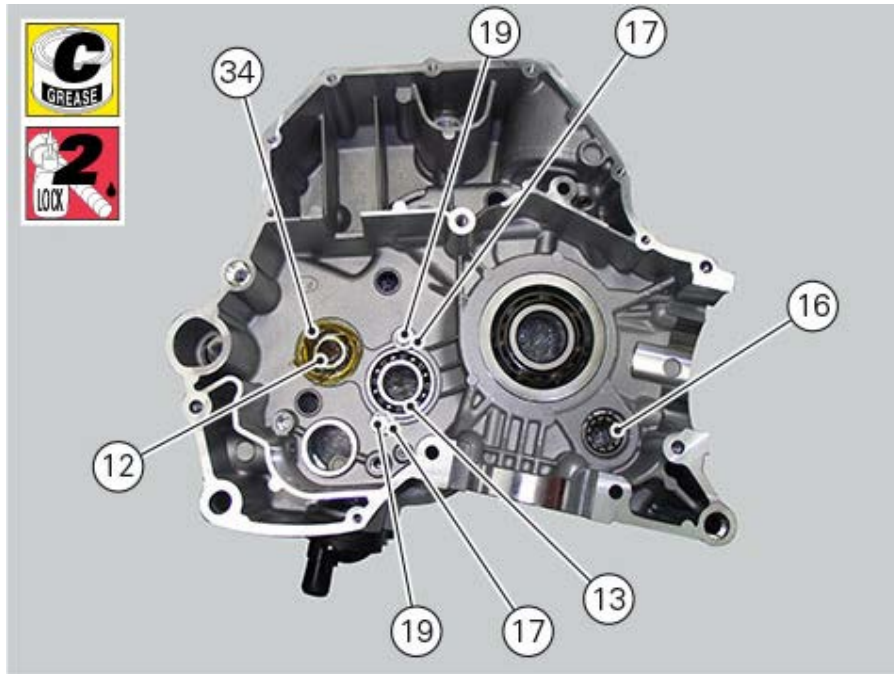

Refitting the generator-side crankcase half

The following parts must be present on the internal side of the crankcase half:

- the double-race ball bearing (11) supporting the selector fork shaft.
- Apply threadlocker to the screws (20). Fit retainer plate (36) on gearbox secondary shaft bearing (11) starting the screws (20) on chain-side crankcase half.

Note

The bearing retainer plate must be positioned with the holes tapering facing upwards.

Tighten the screws (20) to a torque of 10 Nm (Min. 9 Nm - Max. 11 Nm). The gearbox primary shaft end bearing (14) with inner spacer (21): apply grease on the bearing needle rollers.

Drive the inner race (37), removed previously, fully home in the bearing.

Apply grease to the inner race.

The main bearing (9).

The ball bearing (15) with circlip (36) at the timing layshaft, aiming it so that the plastic cage closed side is facing the crankcase half.

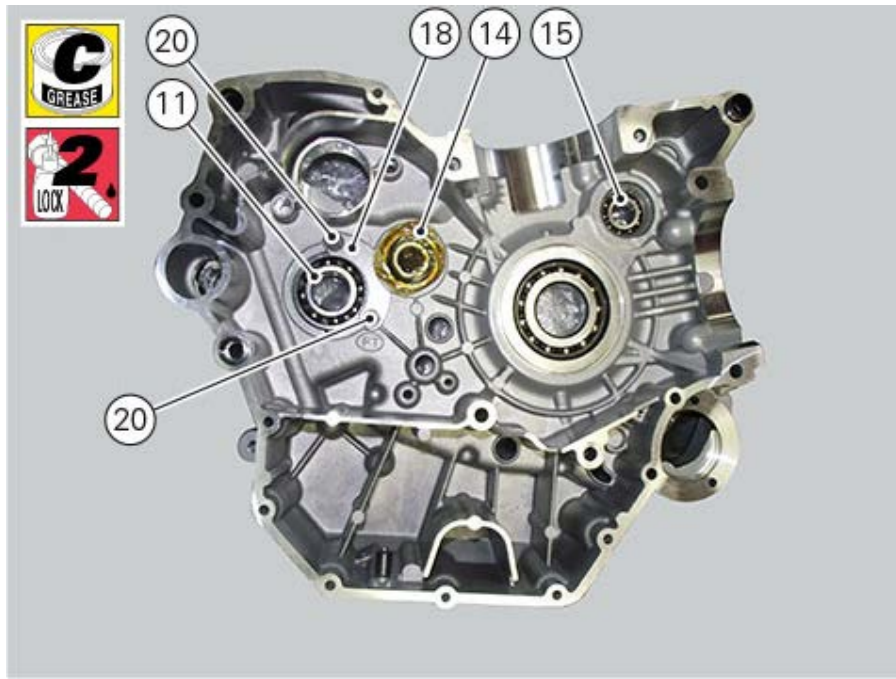

Note

Bearings do not have a specific mounting position (except main bearings), however it is good practice to install the bearings so that the written side is facing inwards.

Main bearings

To replace the bearings proceed as follows:

- heat the crankcase half in an oven to 100 °C;
- remove the bearing using a drift and hammer;
- install the new bearing (while the crankcase is still hot) keeping it perfectly square in its seat using a tubular drift that only bears on the outer ring of the bearing;
- allow the parts to cool and check that the bearing is securely fastened to the crankcase half.

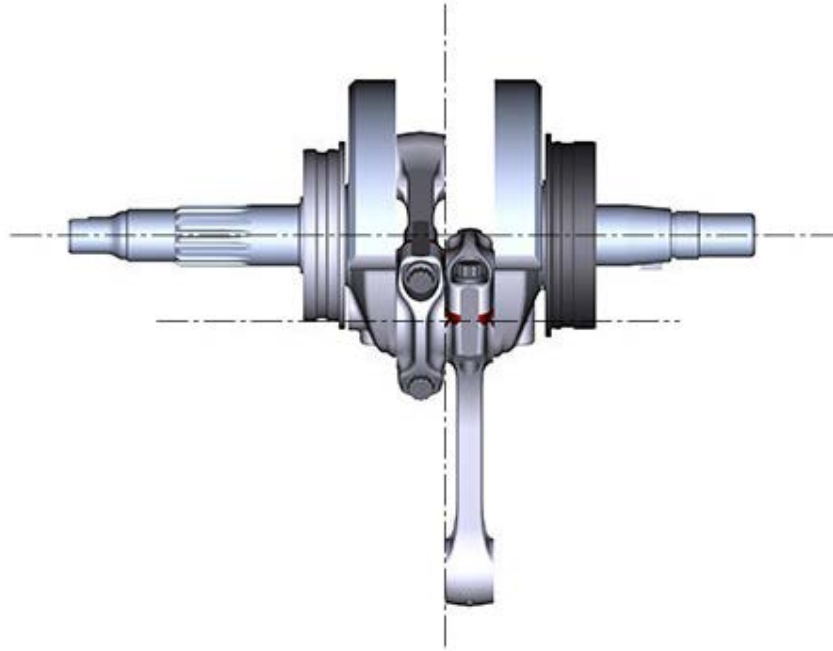

Check that the gap between crankcase and fitted bearings is not lower than 0.03 mm, otherwise replace the crankcase halves.

Overhauling the crankcase halves

Visually inspect the engine crankcase halves.

Check that the surfaces of the crankcase halves are perfectly flat using a reference surface.

Check bearing (9) and (10) conditions.

If they need to be replaced, it is necessary to replace them in pairs.

Warning

When overhauling an engine it is good practice to replace all the crankcase bearings.

Replace the bearings (11) and (12) on the ends of the gearbox secondary shaft and timing layshaft bearings (15) and (16).

When replacing bearings (13) and (14) supporting the gearbox primary shaft, block them on the crankcase half with spacers (17) and stop plate (18) respectively fixed by screws (19) and (20).

Upon each overhaul it is recommended to replace also the seal ring located between bearing (14) and chain-side crankcase half: lubricate the ring with denatured alcohol, introduce it fully home in the crankcase half as shown in the figure.

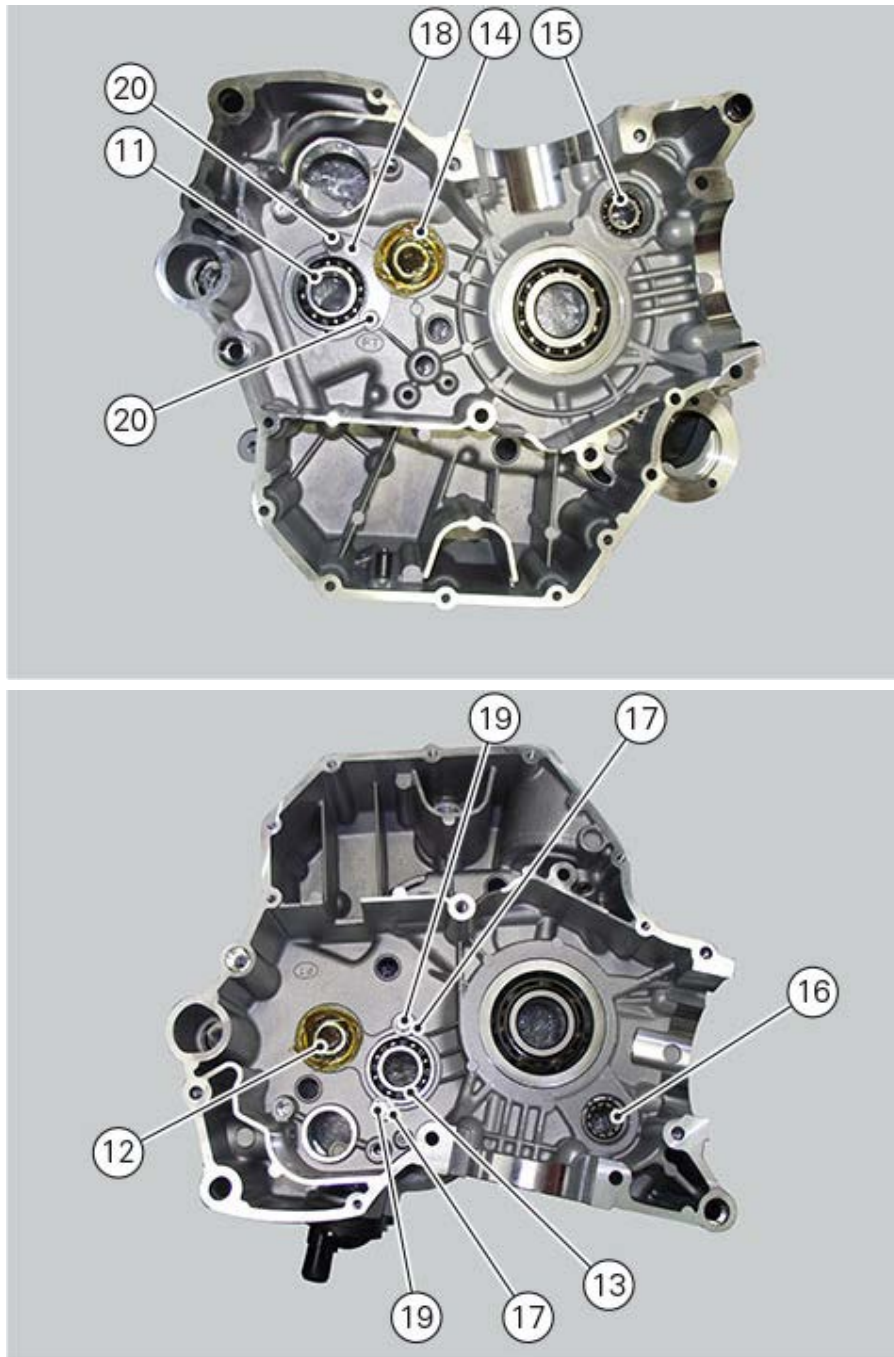

At each overhaul it is recommended to replace also the sealing ring (22) and the seal ring (23).

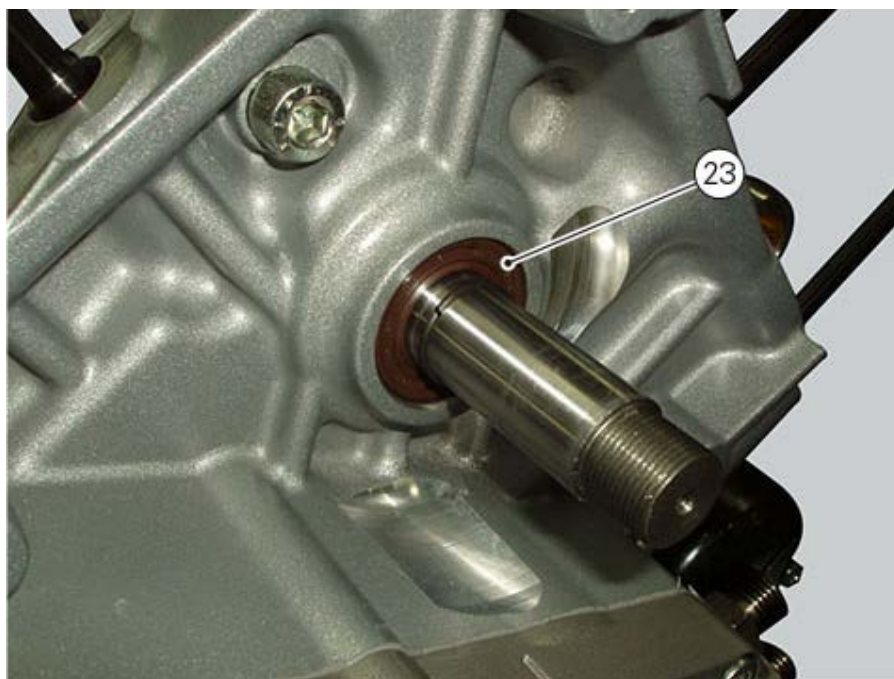
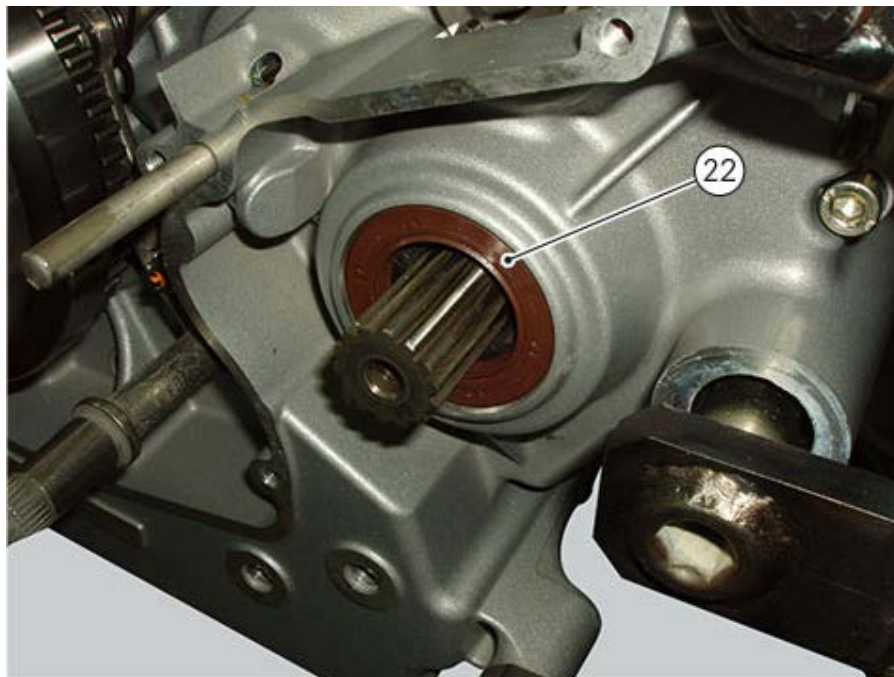

In case of needle roller bearing replacement on the swingarm shaft, proceed as follows:

Chain-side crankcase half

Fit snap ring (24) in hole (25).

Smear specified grease inside hole.

Fit seal ring (26) and the two bearings (27) and (28) respecting the indicated value.

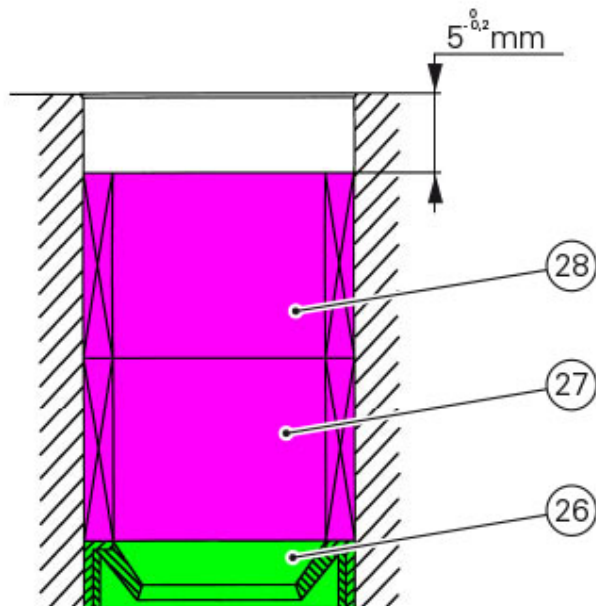
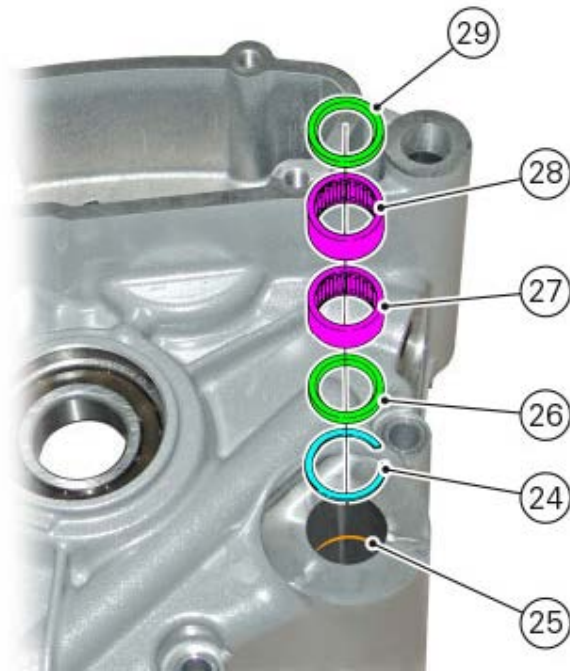

Orient the seal ring (26) as shown. The arrow refers to the insertion direction.

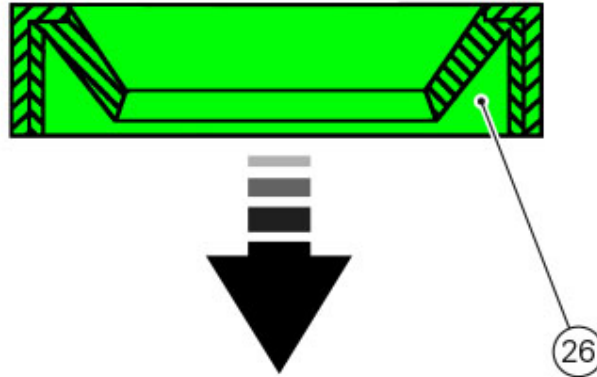

Clutch-side crankcase half

Fit snap ring (31) in the hole.

Smear specified grease inside hole.

Fit seal ring (32) and the two bearings (33) and (34) respecting the indicated value.

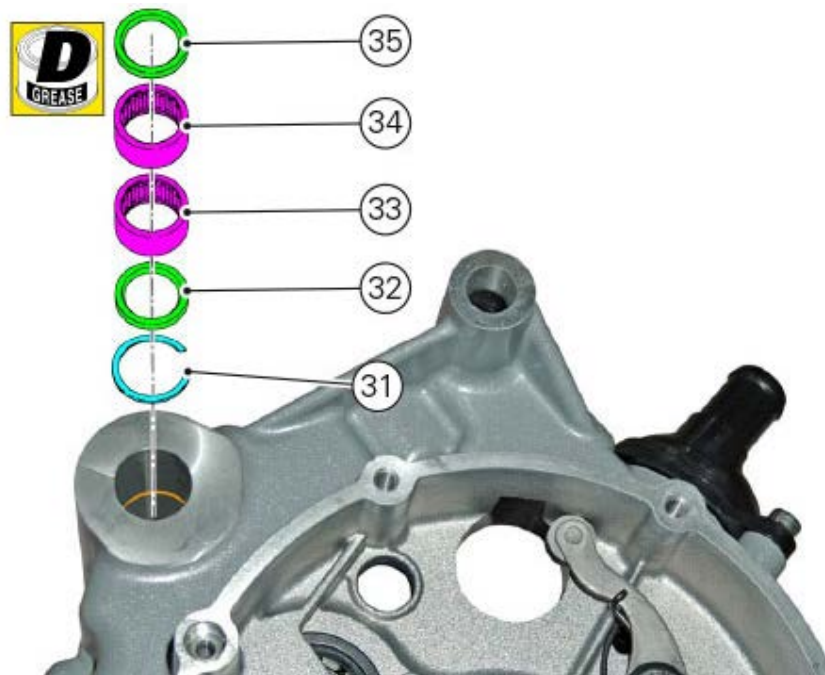

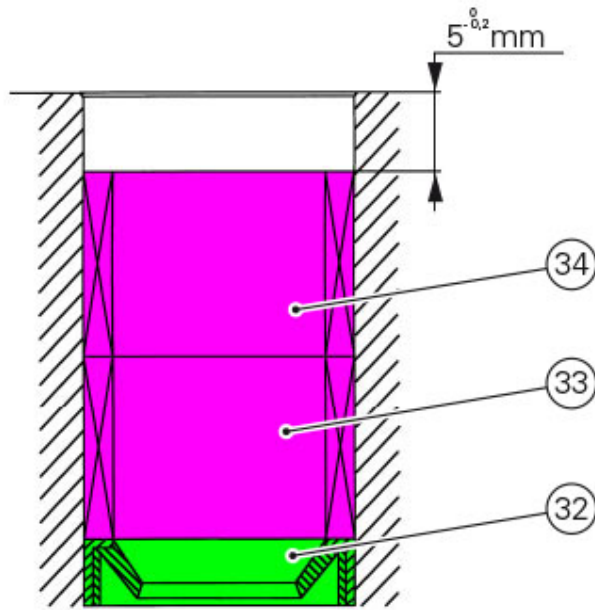

Orient the seal ring (32) as shown. The arrow refers to the insertion direction.

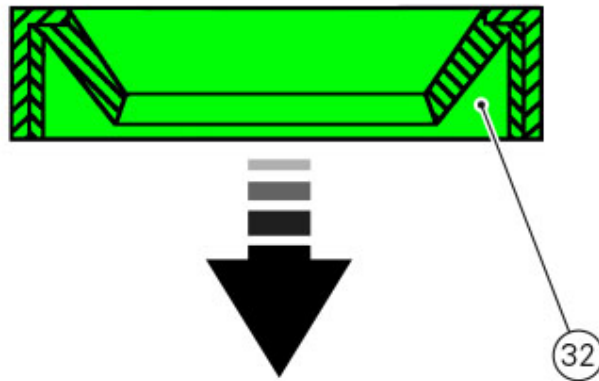

Separating the crankcase halves

Remove the engine from the frame ([Removing the engine](#)).
Remove the clutch cover ([Removing the clutch cover](#)).
Remove the complete clutch unit ([Removing the clutch](#)).
Remove the oil pump ([Removing the oil pump](#)).
Remove the generator cover ([Removing the generator cover](#)).
Remove the heads ([Removing the engine heads](#)).
Remove the cylinder ([Removing the cylinder/piston assembly](#)).
Remove the starter motor idler gear ([Removing the starter motor idler gear](#)).

Use two screwdrivers to remove the snap ring (1) from the timing layshaft (2) on the clutch-side crankcase half.

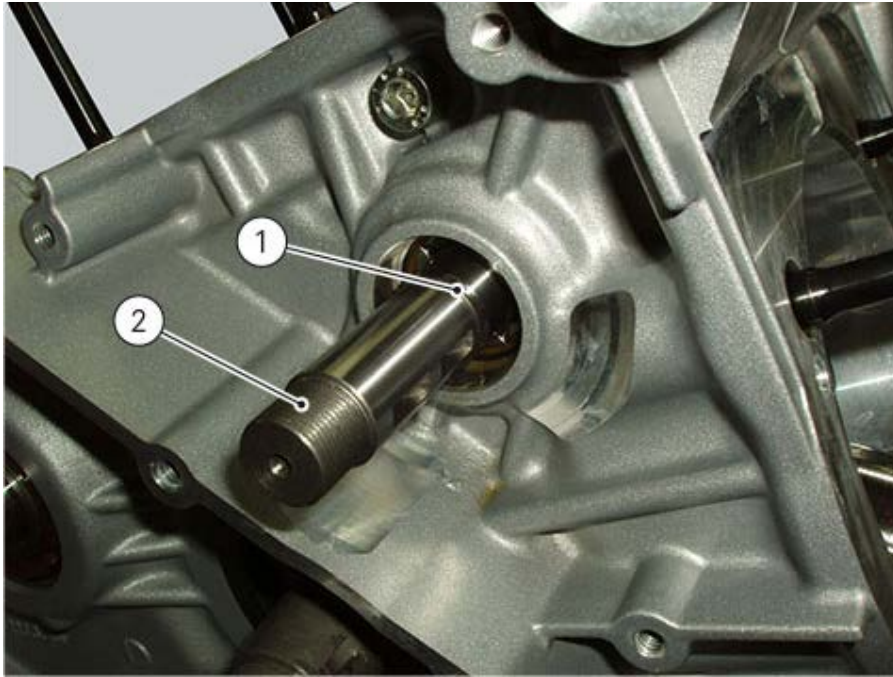

Loosen crankcase half jointing screws (3), (4) and (5) on generator side.

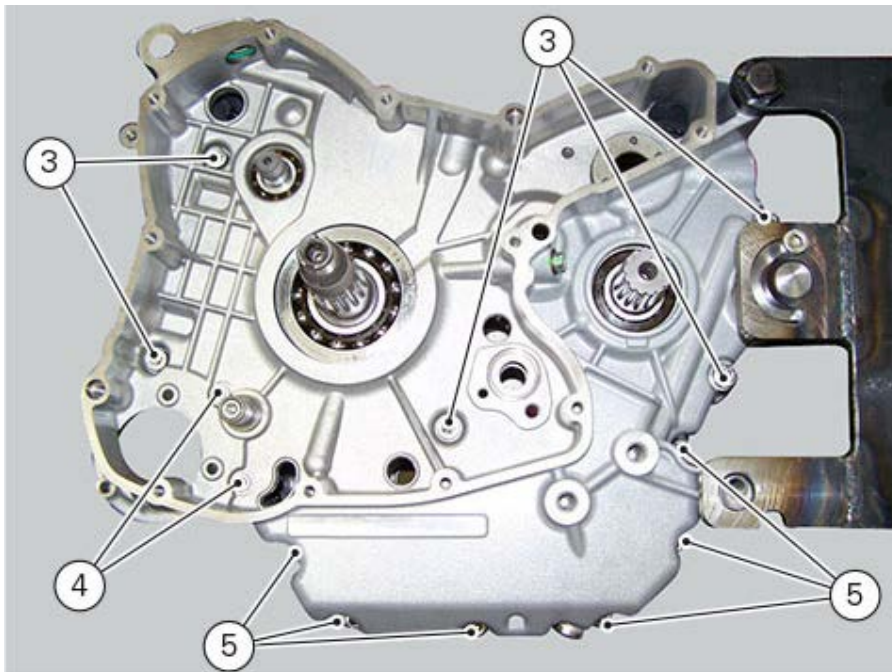

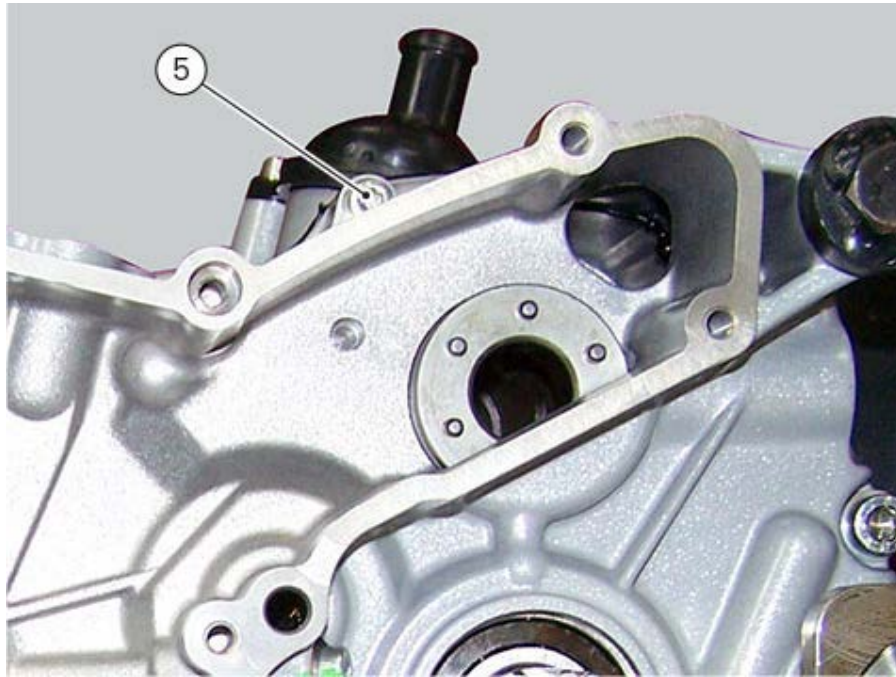

Undo the two screws (3) on the clutch side crankcase half near the vertical cylinder seat.

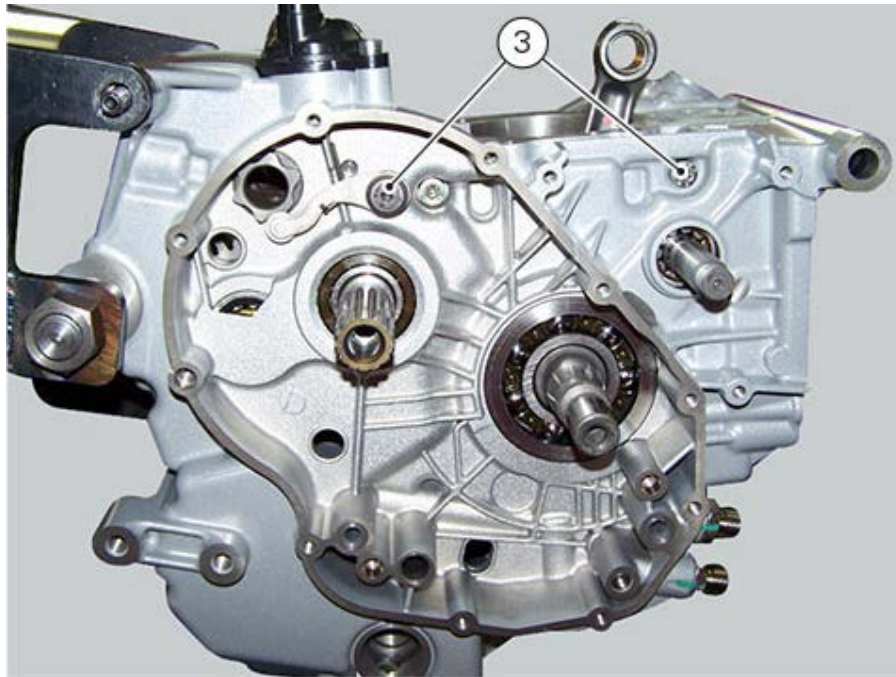

Reuse the generator cover or a service cover with puller (A) part no. **88713.1749** fitted. Secure cover to crankcase half with some of the original screws and begin separation by turning the central pin of the tool. Tap the end of the gearbox secondary shaft with a plastic mallet to separate the crankcase halves.

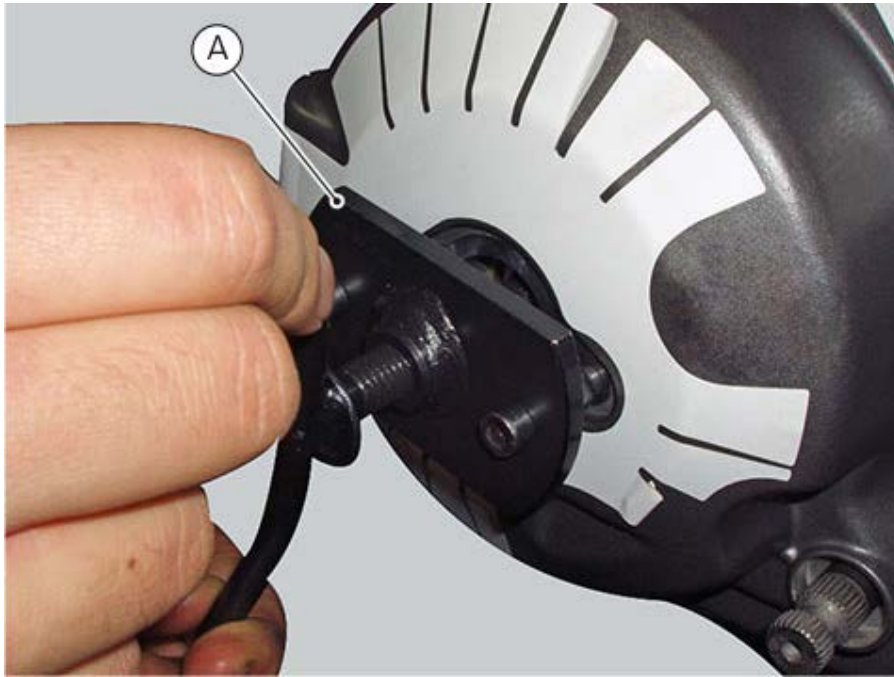

Remove the gearbox shafts and the gearbox selector drum from the crankcase halves.
Drive out the crankshaft (6) using a plastic mallet, paying attention not to damage washers (7).
Remove the timing layshaft (2).
Recover O-ring (8) in the oil passage between crankcase halves.

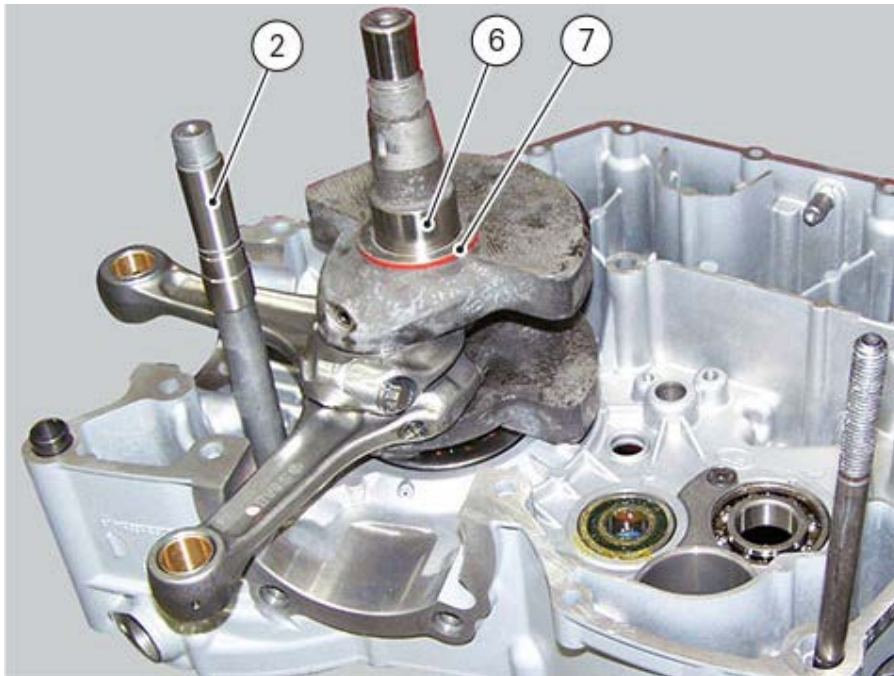

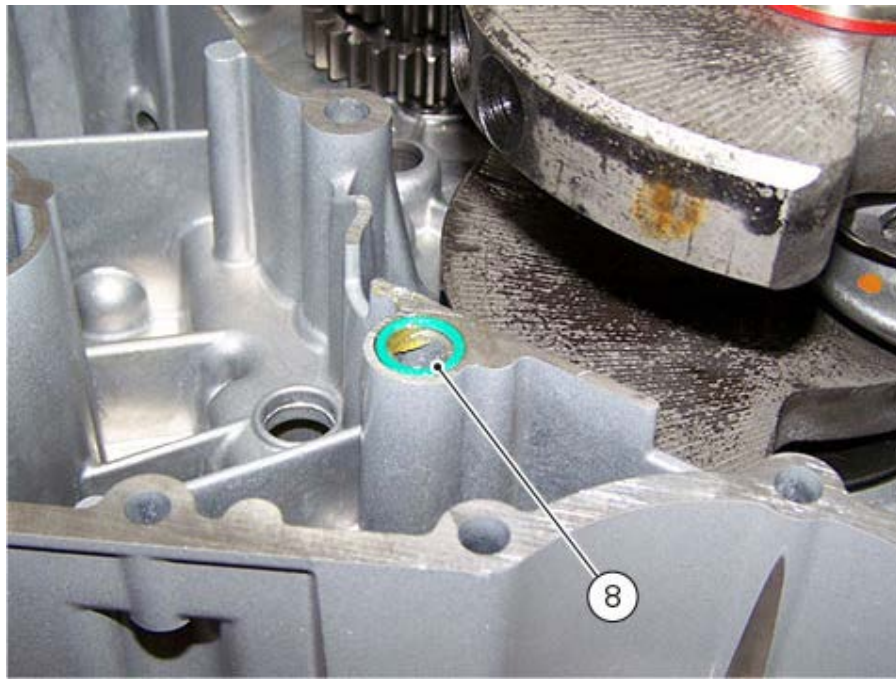

Reassembling the connecting rod assembly

Before starting, check that the crankshaft main bearing and big-end journals are free of burrs or evident signs of machining: if necessary, clean the surfaces with very fine emery cloth and oil.
Check that the grooves are in perfect condition with no signs of forcing.
Check that each connecting rod is fitted with its centring pins (8) between cap and the relevant shank.

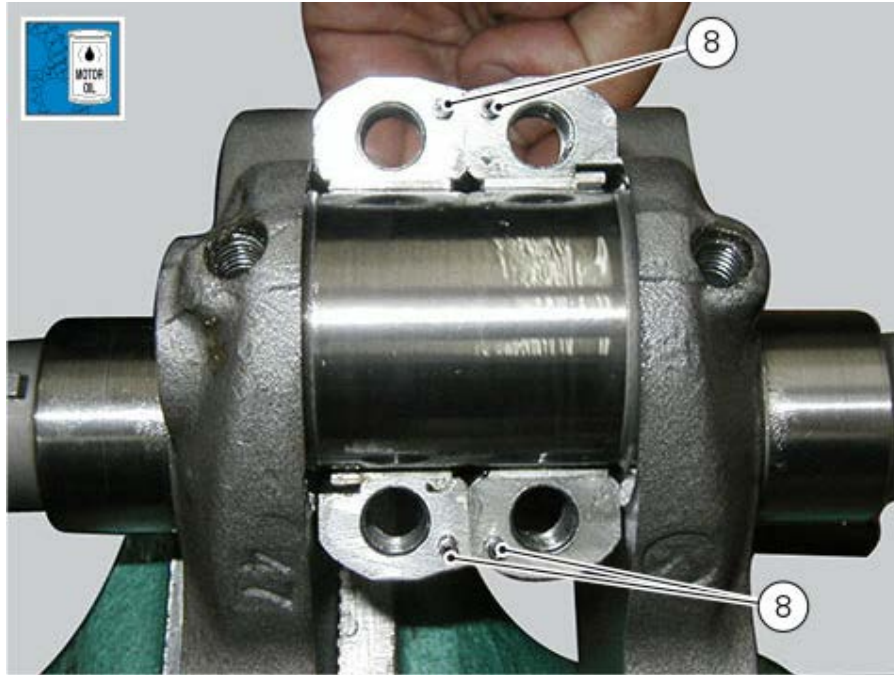

If the crankshaft or one or both con-rods need to be replaced, you must match crankshaft and con-rods according to their weight, as described in the procedure below:

Check the crankshaft class (1).



Check the con-rod class (2).



It is good practice to replace the bearings (A) each time the engine is overhauled. Spare bearings are supplied ready for fitting and they must not be reworked with scrapers or emery cloth.

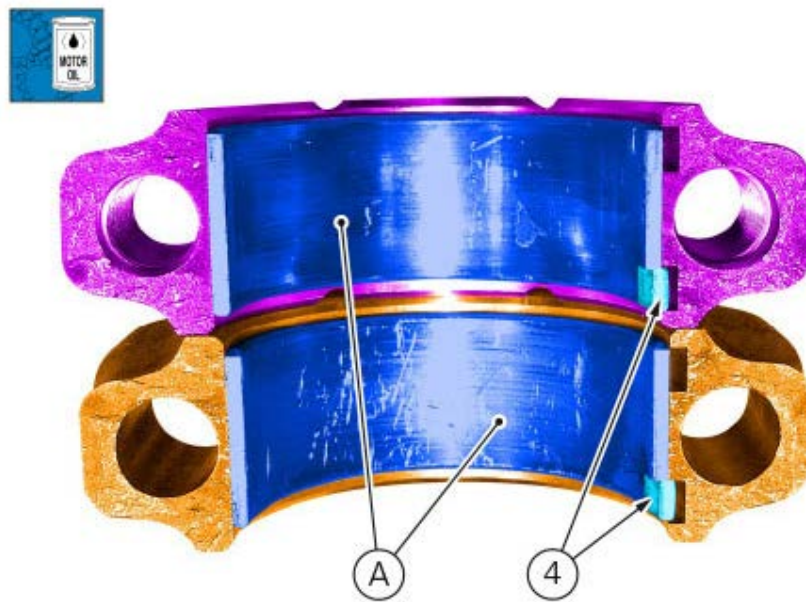

Check that the progressive number punched on the two parts sides is the same, as shown in the figure.

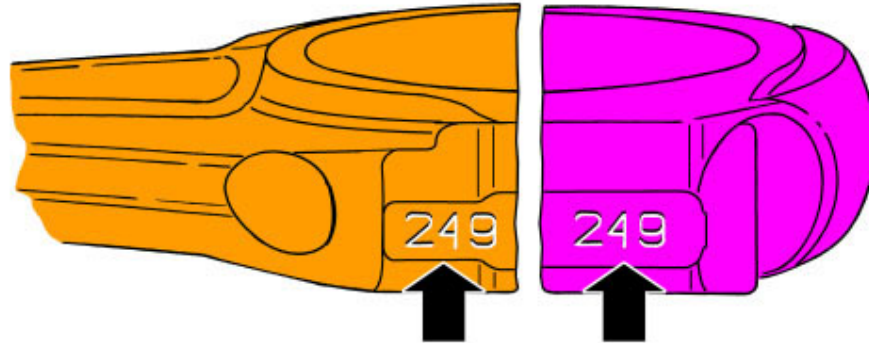

Couple crankshaft and connecting rod big end bearings following the indications provided in the table.

Crankshaft class	Connecting rod class	Connecting rod big end bearing colour	Connecting rod cap big end bearing colour
A	A	RED	RED
B	B	BLUE	BLUE

Insert bearing shells in the connecting rod head matching the tooth (4) with the corresponding marks on the connecting rod cap and on the connecting rod shank.

Use the indicated product to lubricate the crank pin (5) and the con-rod big end bearing (4).

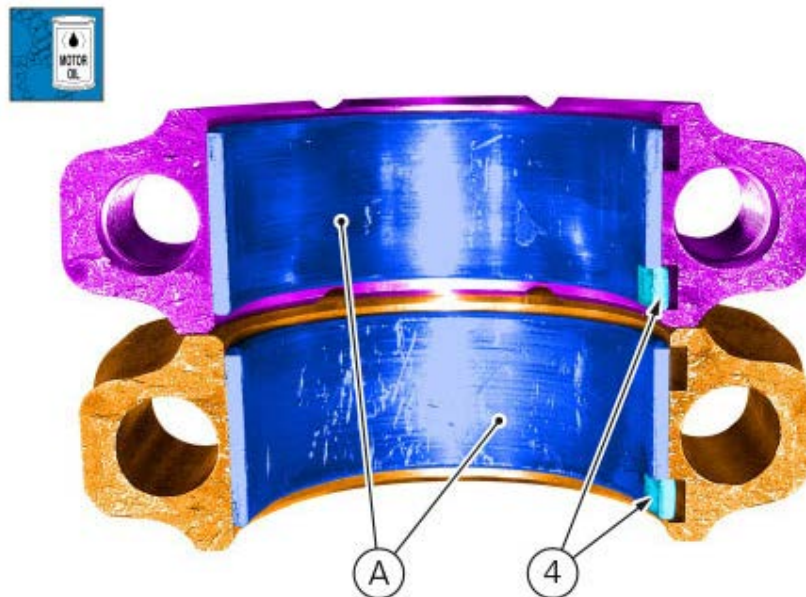

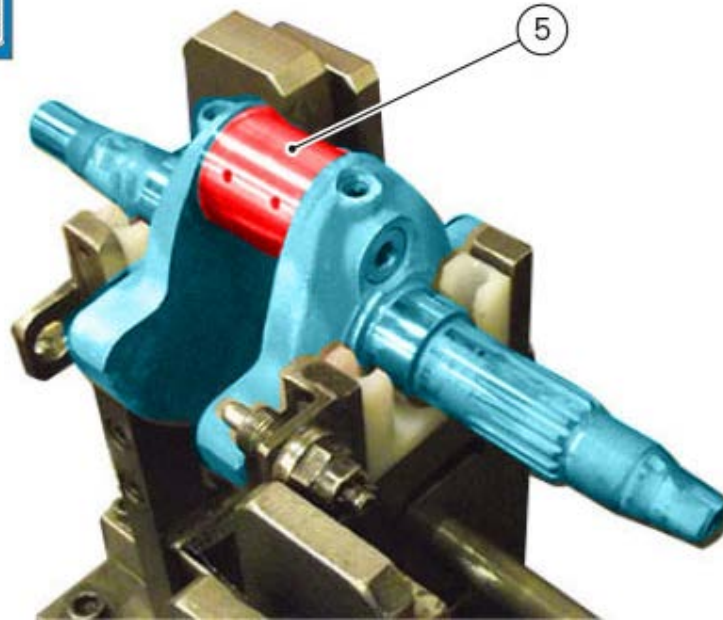

Wash the pins and dry them with compressed air.
Clean and use engine oil to lubricate the crank pin and the bearing shells and refit the con-rods on the crankshaft, in the position they were when they were removed.
Fit the cap and the relevant con-rod with the mark on the same side.

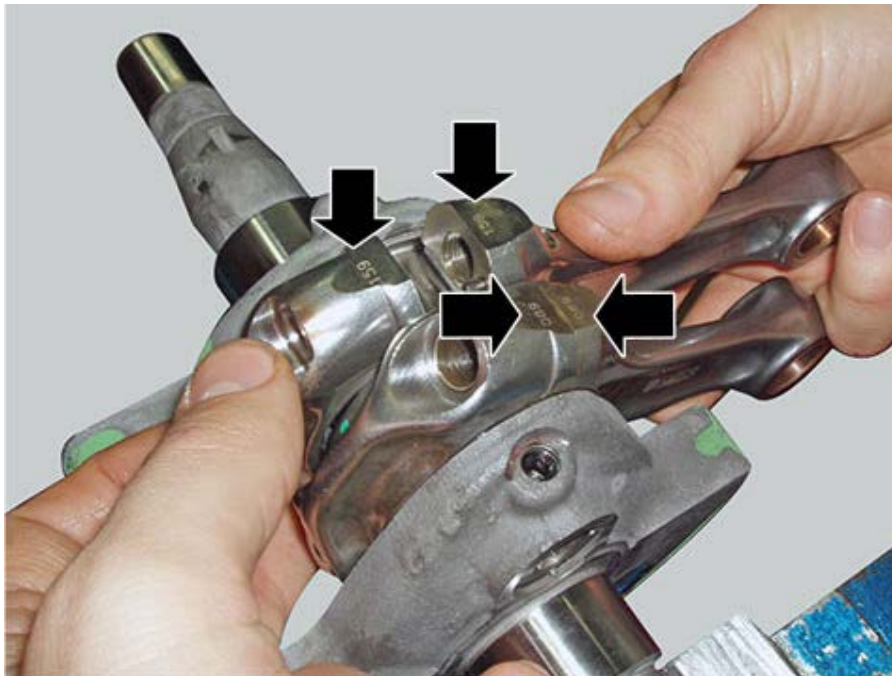

Fill the recommended grease into the two ends of the hole to lubricate threads and underside of the new screws (3) and the thread of the shaft.



Warning

The grease utilised is irritant in contact with the skin; wear protective gloves.



Important

Lubrication of con-rod bolts is essential to obtain the correct coupling and to prevent breakage of the parts.

The con-rod screws may only be used for one tightening.

Temporarily fit the gudgeon pin (9) to align the connecting rods.

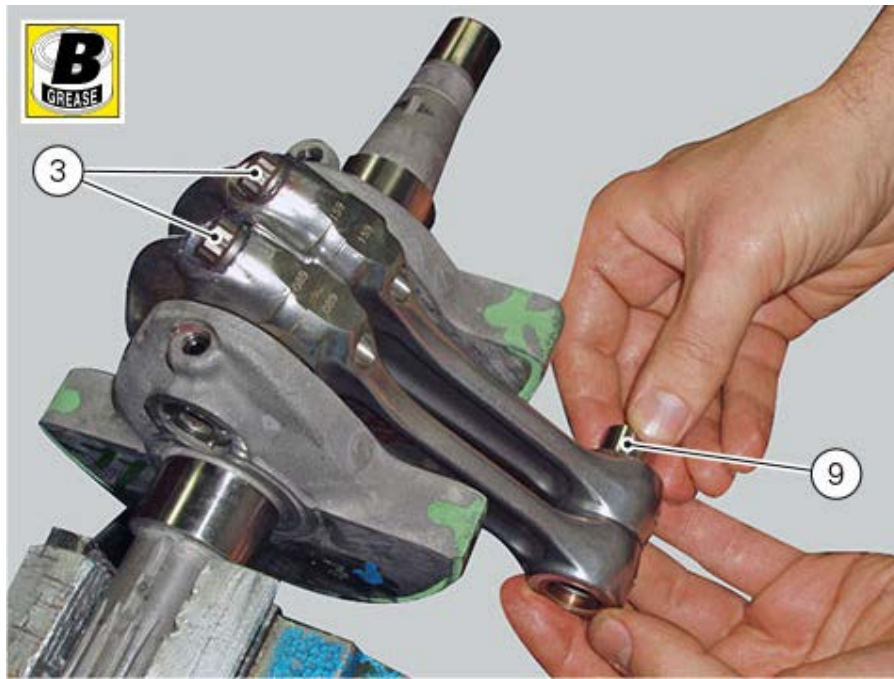

Put the spacer of tool no. **88713.2878** between the con-rods and take up residual axial clearance with the fork feeler gauge of tool no. **88713.2878** which has shims of the following sizes: - 0.1 mm - 0.2 mm - 0.3 mm.

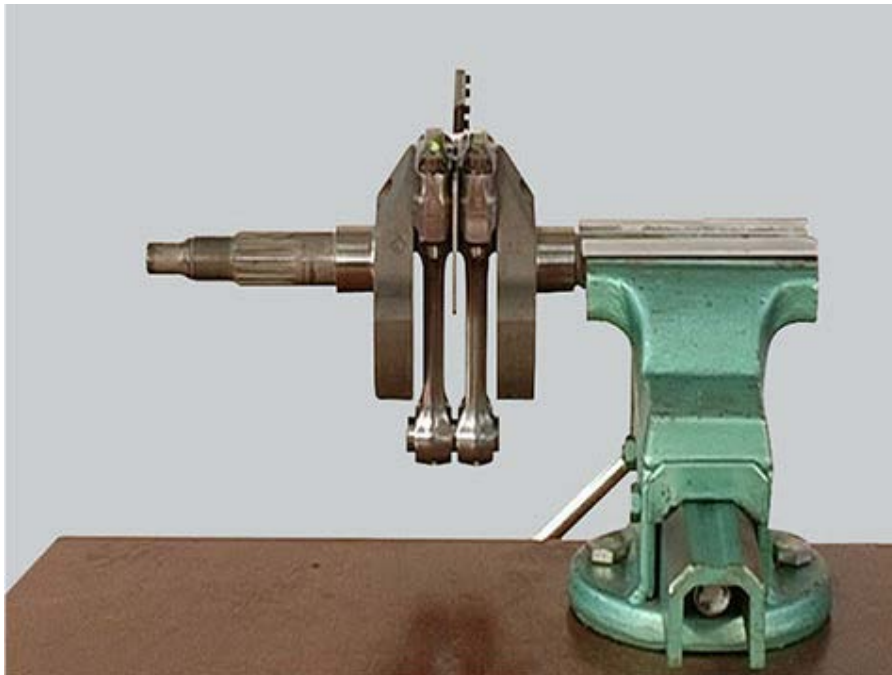

Using a torque wrench as shown in the figure, tighten screws (3) to the values specified here below:

- tighten to 35 Nm;
- pause of 2 seconds and 360° loosening;
- pre-tighten again to 20 Nm;
- pre-tighten again to 35 Nm;
- tighten to 65 ± 1
- torque check $70 \div 103$ Nm.

Remove the feeler gauge and check that connecting rods/crankshaft end float is: $0.15 \div 0.35$ mm.

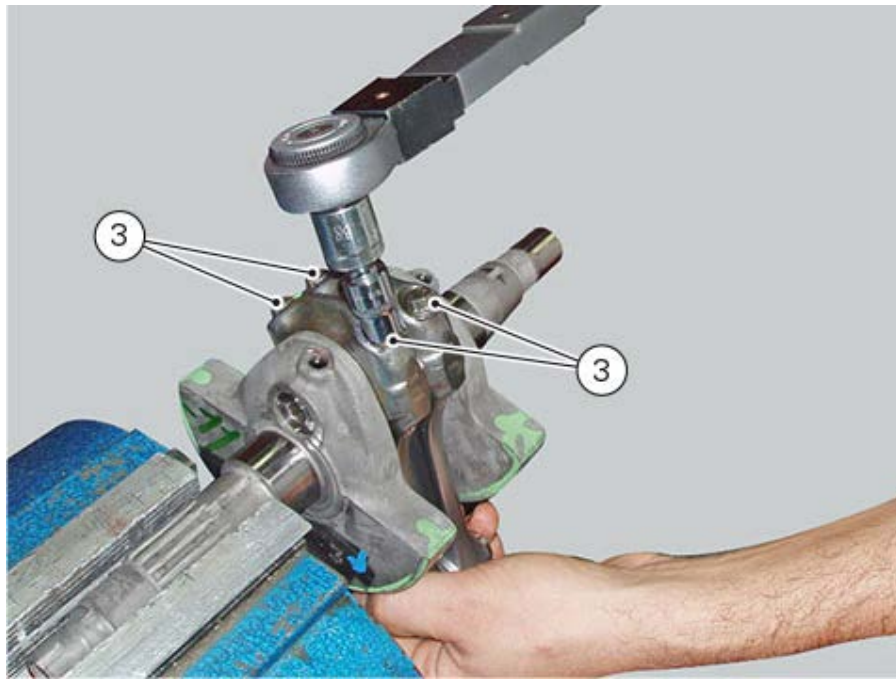

Overhauling the connecting rod assembly

Make the following dimensional checks on the connecting rods:

- clearance with gudgeon pin upon fitting.

In case of excessive wear, replace the connecting rod. The small end bush must be in good condition and firmly driven into its seat.

Check the parallelism error measured at 100 mm from the connecting rod longitudinal axis: it must be H-h lower than 0.02 mm; otherwise, replace the con-rod.

Connecting rod big-end diameter must be within the specified limits.

It is preferable to use crankshafts and connecting rods of the same size class.

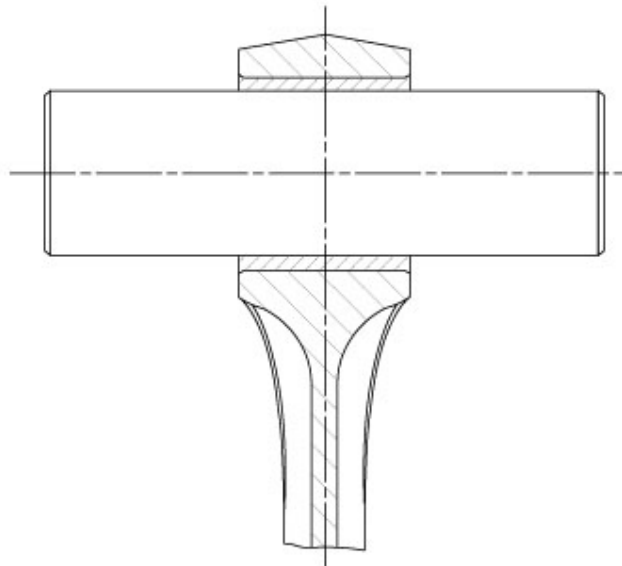
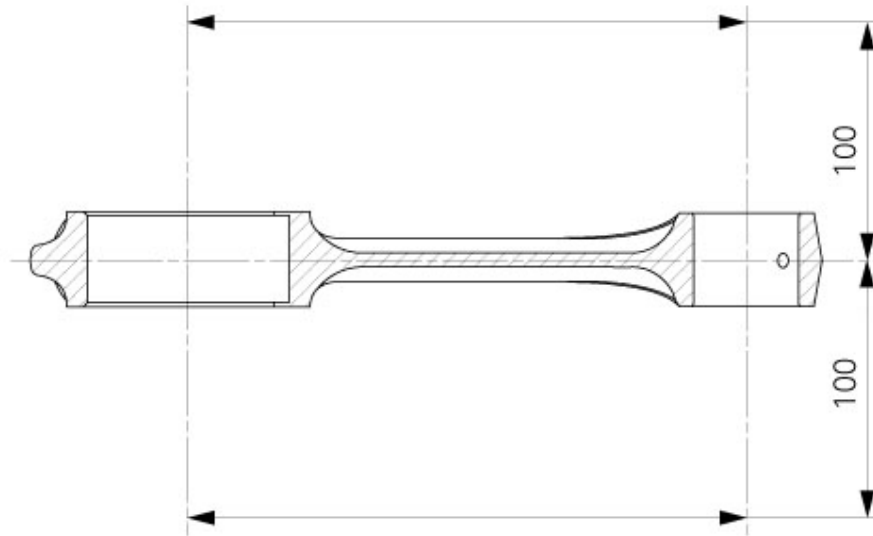

Replacing connecting rod big end bearings

It is good practice to replace the bearings (4) each time the engine is overhauled.

Spare bearings are supplied ready for fitting and they must not be reworked with scrapers or emery cloth.

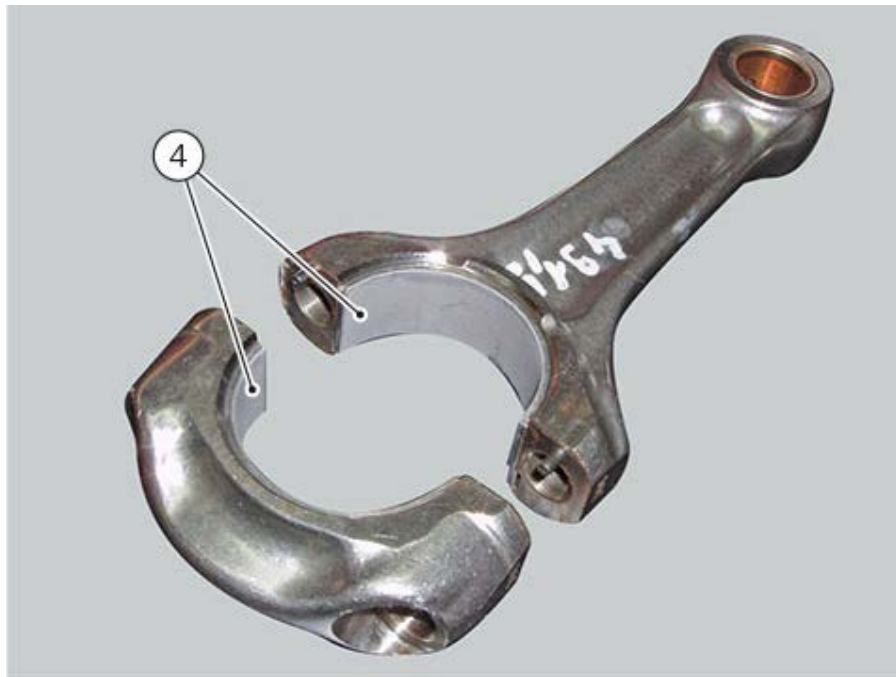

Overhauling the crankshaft

The journals for main bearings and crank pin should not be scored or grooved.

The threads, keyways, and slots must be in good condition.

Check for fretting or burrs in the fillet between journal and shoulder.

Fillet radius: 1.5 mm.

Use a micrometer to measure oval and taper value of the crank pin. Measure oval and taper in several different directions.

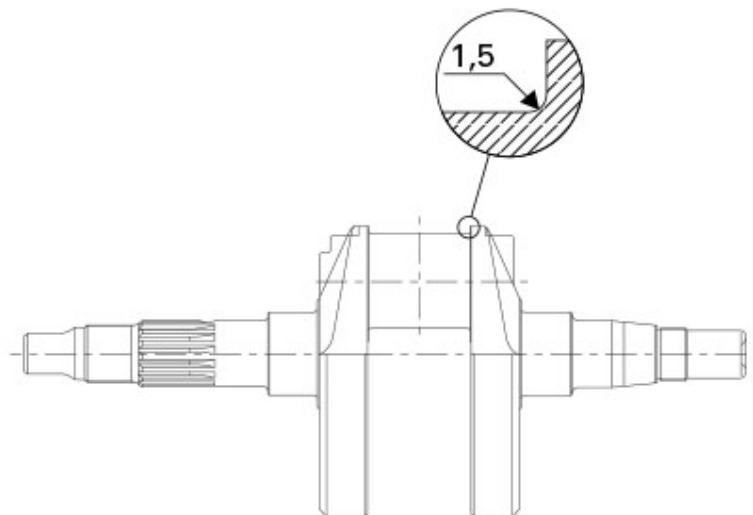

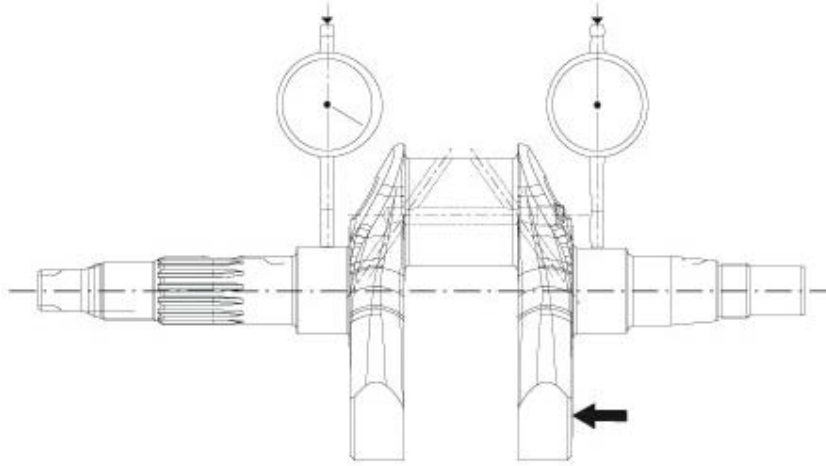

Use a dial gauge to measure the alignment of the main journals by positioning the crankshaft between two centres.
Loosen all crankshaft plugs (5), (6) and (7), heating the crankshaft, if necessary, to remove the sealant applied at the time of assembly.

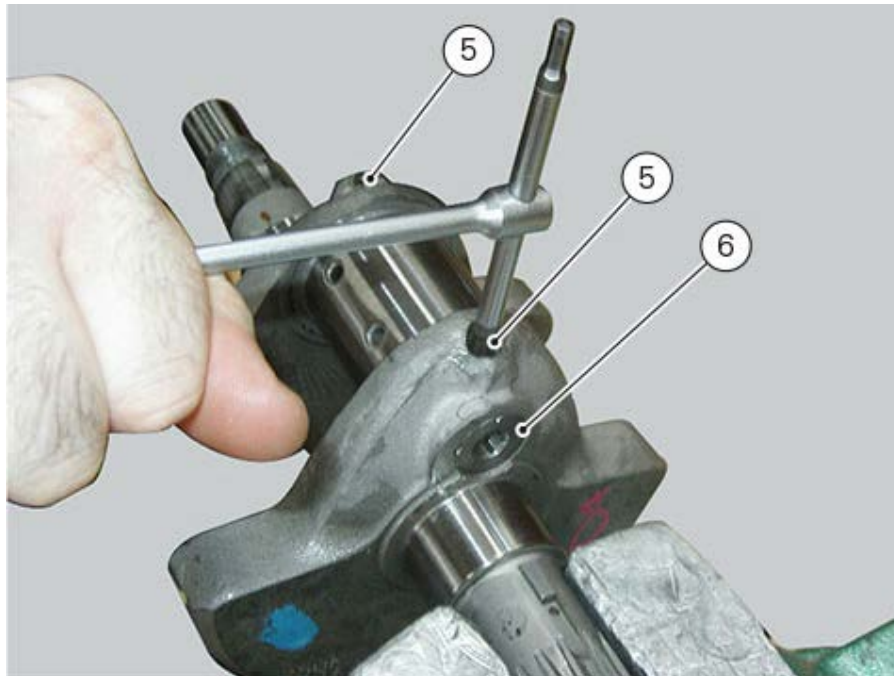

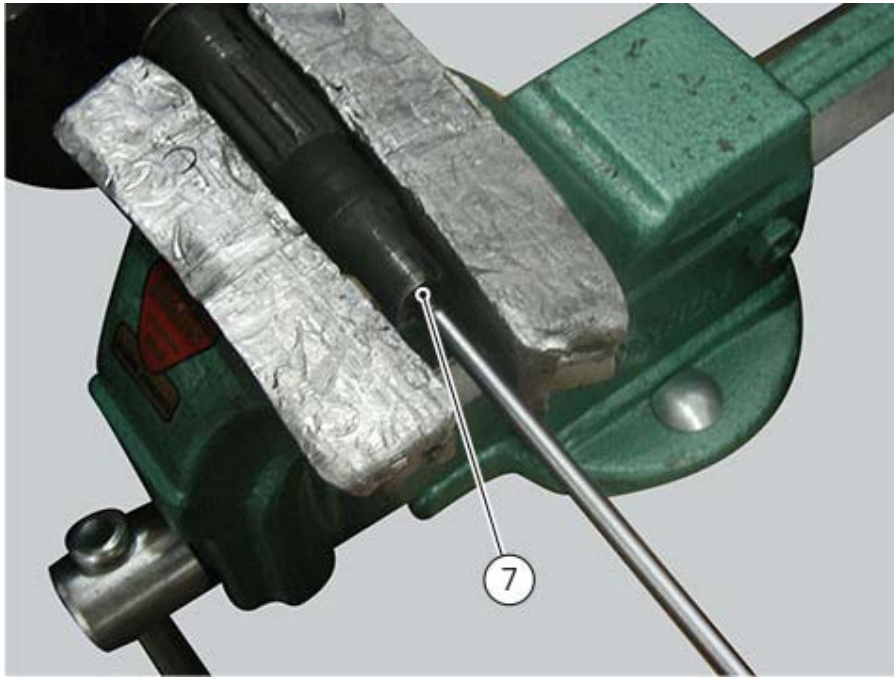

To carry out this operation, use a heat gun able to reach 150 °C.

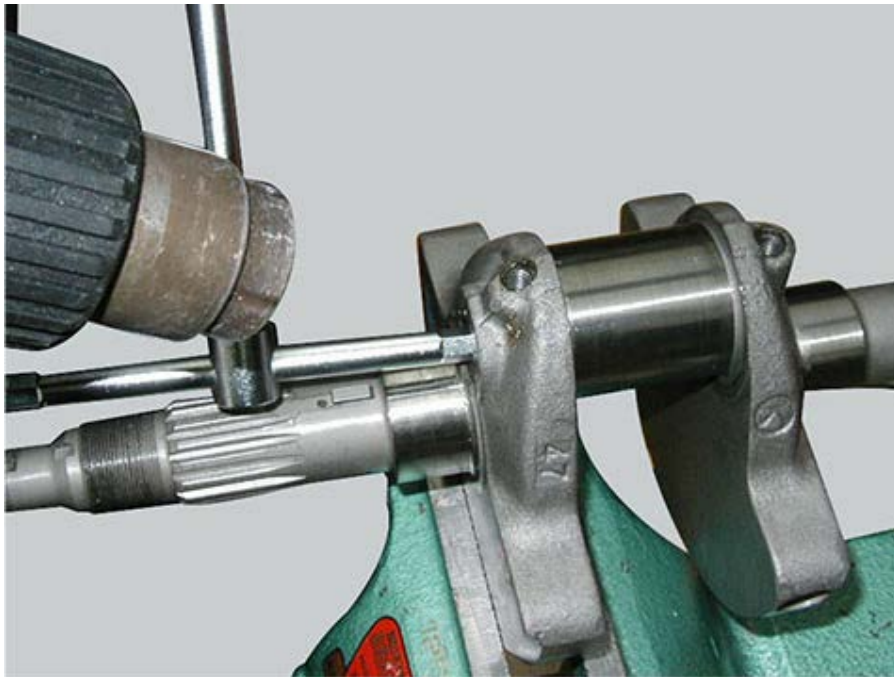

Clean all the oilways using suitable diameter metal brushes and then blow with compressed air to remove any residues that may have accumulated and are restricting the oil flow.

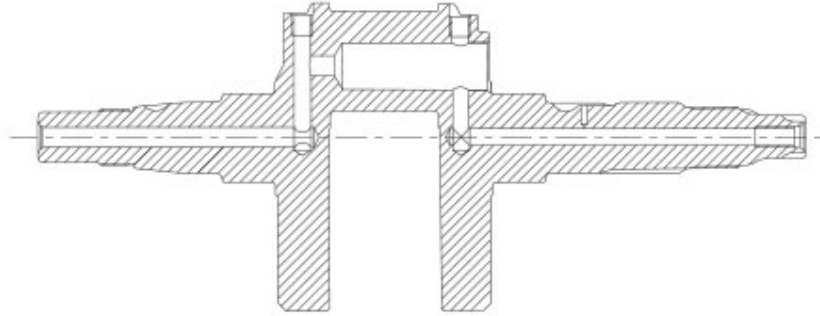

Apply specified threadlocker to the threads of plugs (5), (6) and (7), then refit them.

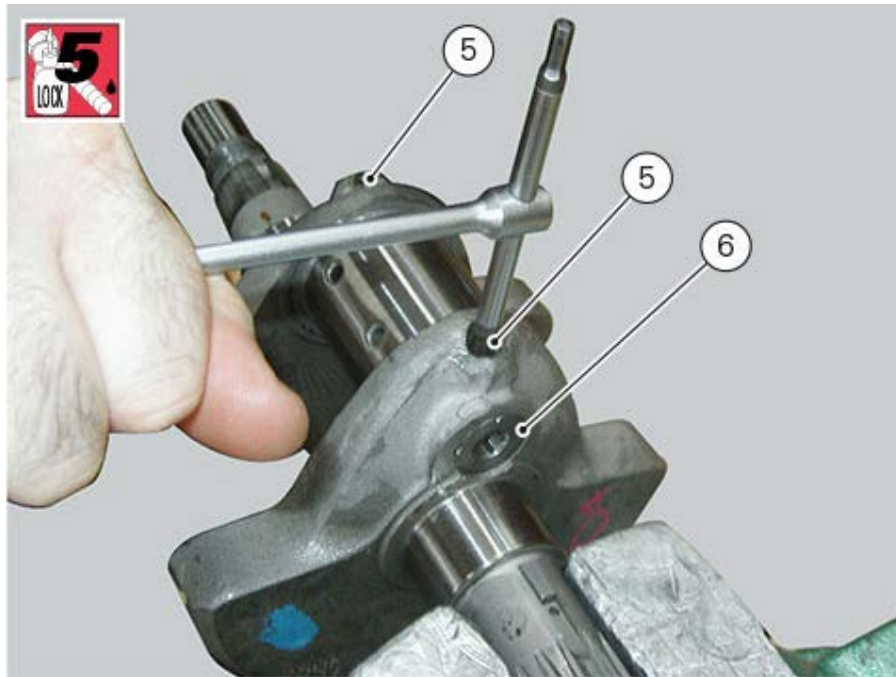

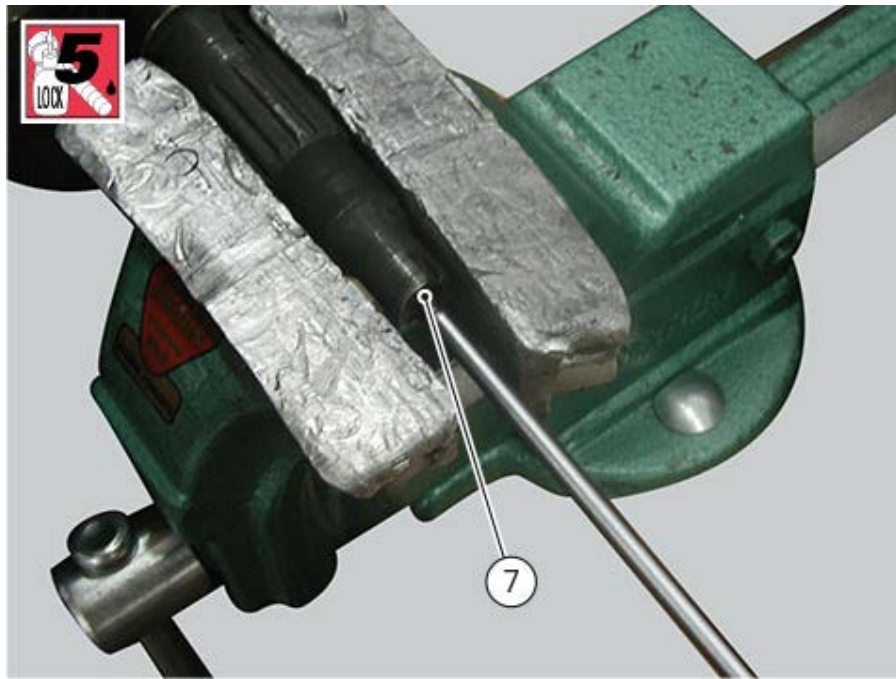

Tighten plugs (5) and (7) to a torque of 13 Nm (Min. 11 Nm - Max. 15 Nm) and plug (6) to a torque of 15 Nm (Min. 13.5 Nm - Max. 16.5 Nm).

Big-end bearing-crank pin clearance

To check the assembly clearance between the bearing shells and crankshaft use a strip (A) of GREEN "Plastigage PG-1" on the journal.

Fit the connecting rod with the original bearings (4) and tighten the screws (3) to a torque of 49 Nm. Remove the connecting rod and compare the thickness of the strip to the scale.

If the detected shim, corresponding to the present clearance, does not fall within the specified limits

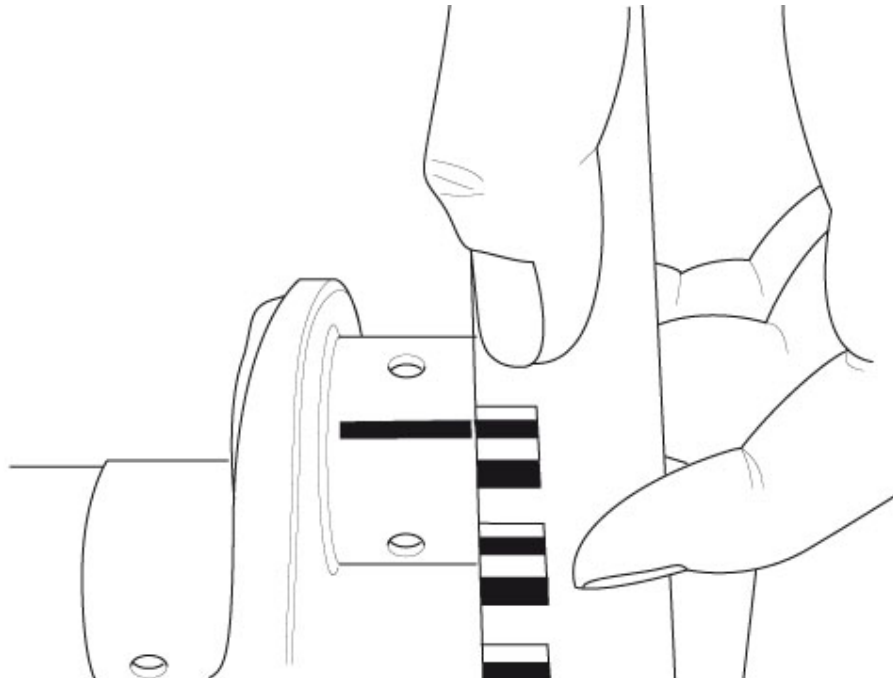

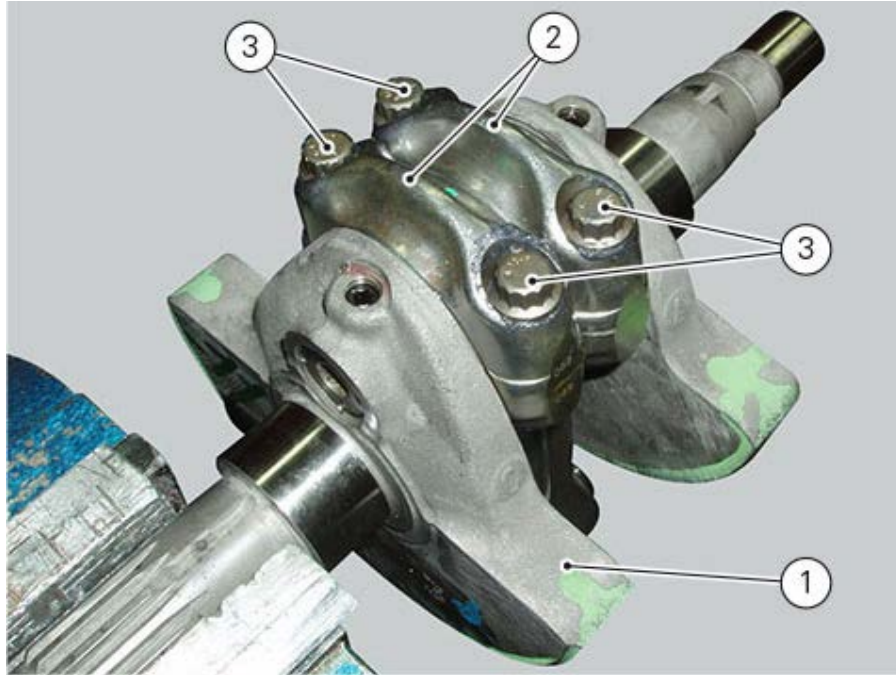
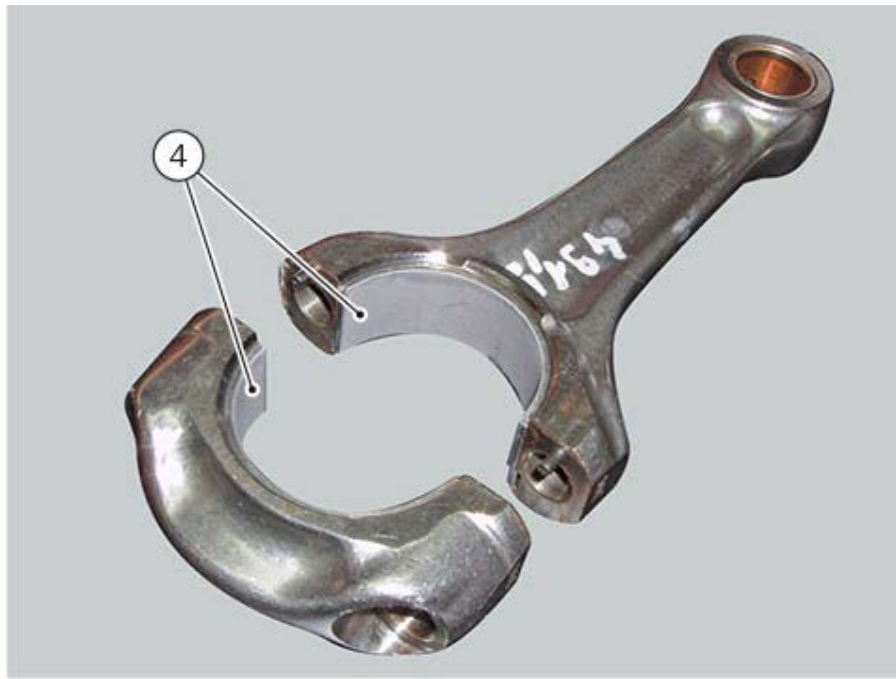

Disassembling the connecting rod assembly

Important

Take care not to mix up components of different connecting rods and maintain the original orientation.

To disassemble the connecting rod assembly, loosen screws (3) and separate connecting rods (2) from crankshaft (1).

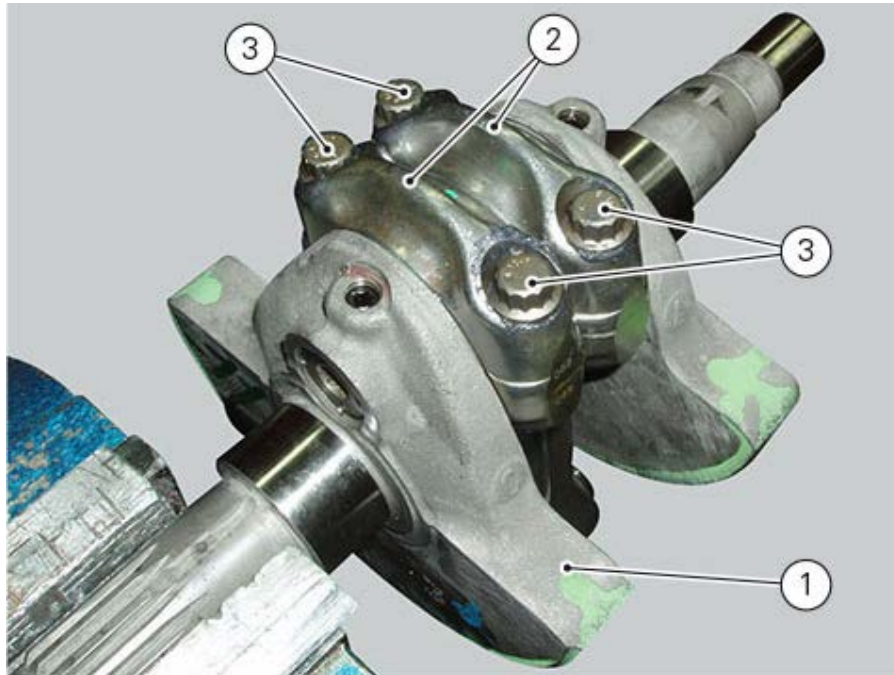

Removing the connecting rod assembly

- Remove the engine from the frame ([Removing the engine](#)).
- Remove the clutch cover ([Removing the clutch cover](#)).
- Remove the complete clutch unit ([Removing the clutch](#)).
- Remove the oil pump ([Removing the oil pump](#)).
- Remove the generator cover ([Removing the generator cover](#)).
- Remove the heads ([Removing the engine heads](#)).
- Remove the cylinder ([Removing the cylinder/piston assembly](#)).
- Remove the starter motor idler gear ([Removing the starter motor idler gear](#)).

After separating the crankcase halves, remove the crankshaft (1) complete with connecting rods (2).

